

InVision Element Table™

37128

Touchboards

205 Westwood Ave, Long Branch, NJ 07740
Phone: 866-94 BOARDS (26273) / (732)-222-1511
Fax: (732)-222-7088 | E-mail: sales@touchboards.com

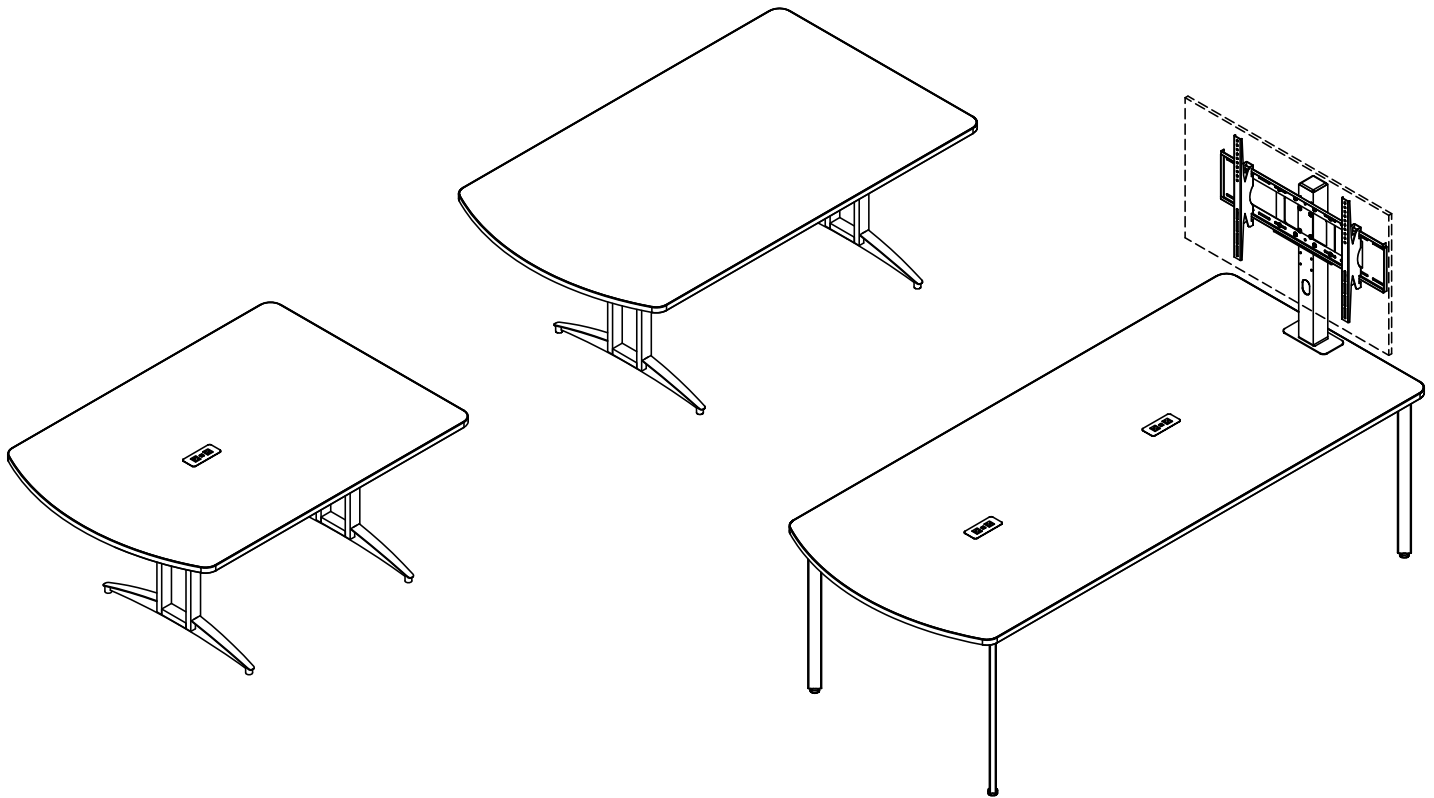

Important

Before using this product:

- Read this manual
- Comply with all safety and operating instructions
- Ensure all parts and correct quantities are included

Any parts damaged during shipment must be reported within 15 days of receipt. To report information regarding missing parts or damage, to purchase parts or accessories, or if you have any questions, please contact us.

Thank you for purchasing Spectrum products!

Spectrum Industries, Inc
925 First Avenue, Chippewa Falls, WI 54729 USA
800 235 1262
715 723 6750
www.spectrumfurniture.com



Important Safety and Care Instructions



- Read this owner's manual before assembly or operation.
- Do not allow children to move the table.
- For indoor use only. Do not install or store the table where it will be exposed to moisture.
- Do not block the ventilation openings.
- Do not allow anyone to sit, stand, or climb on the table.
- Use a damp, soft-cloth, or sponge, with mild soap or detergent solution to clean dirty surfaces. Do not use harsh solvents or abrasives.
- This table is intended for institutional use. It does not have any user-serviceable parts or user-maintenance requirements. If servicing is necessary, please contact Spectrum Industries for assistance.

Warning - Relocating audio and/or video equipment to furniture not specifically designed to support audio and/or video equipment may result in death or serious injury due to the furnishing collapsing or over turning onto a child.

Warning - Death or serious injury may occur when children climb on audio and/or video equipment furniture. A remote control or toys placed on the furnishing may encourage a child to climb on the furnishing and as a result the furnishing may tip over on to the child.

Electrical Safety:

- Keep the power switch in the OFF position before plugging or unplugging from the wall outlet.
- Ensure total device / equipment load does not exceed 12-amps.
- Do not plug the power cord into an extension cord.
- Inspect the power cords for damage before each use. Do not use power cords that are damaged.
- Unplug power cord from electrical outlet by gripping the cord. Do not unplug the power cord by pulling only on the cord.
- Do not step on, drive over, drag, or place objects on the power cord.
- For added safety, plug the cart into a grounded outlet controlled by a GFI (Ground Fault Interrupter) circuit breaker.
- Damaged electrical components can create significant hazards to users and is not covered by the warranty. Repairs should always be performed by a qualified electrician.
- Electrical devices are not toys. Children are often unaware of the hazards associated with electrical devices. This table must always be used by adults or with adult supervision.

Components

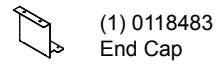
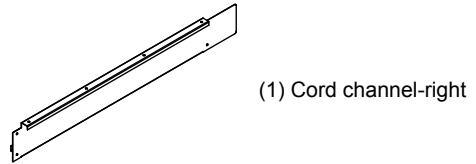
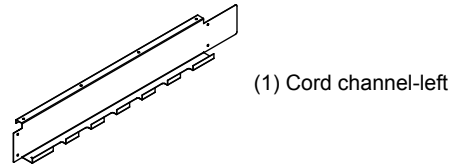
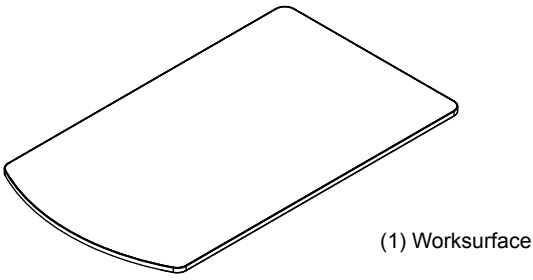

T-Leg Components

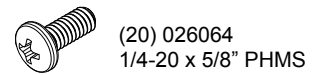
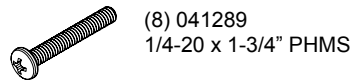
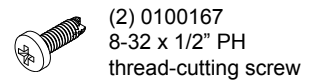
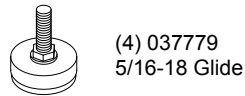
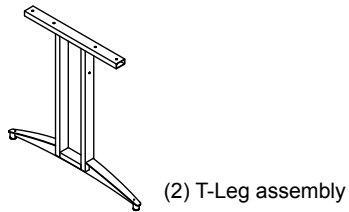

Corner Post Components

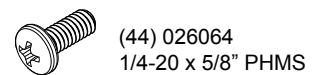
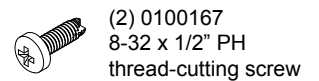
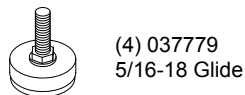
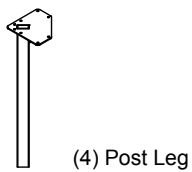

Assembly / Setup - Table with T-Legs

1. Attach T-Legs to worksurface

1. Place the worksurface upside-down (laminated side-down) onto a flat, non-abrasive surface like another table. **Figure 1A.**
2. Attach the two T-legs as shown with 1/4-20 x 5/8" PHM screws.
3. Install the four glides.

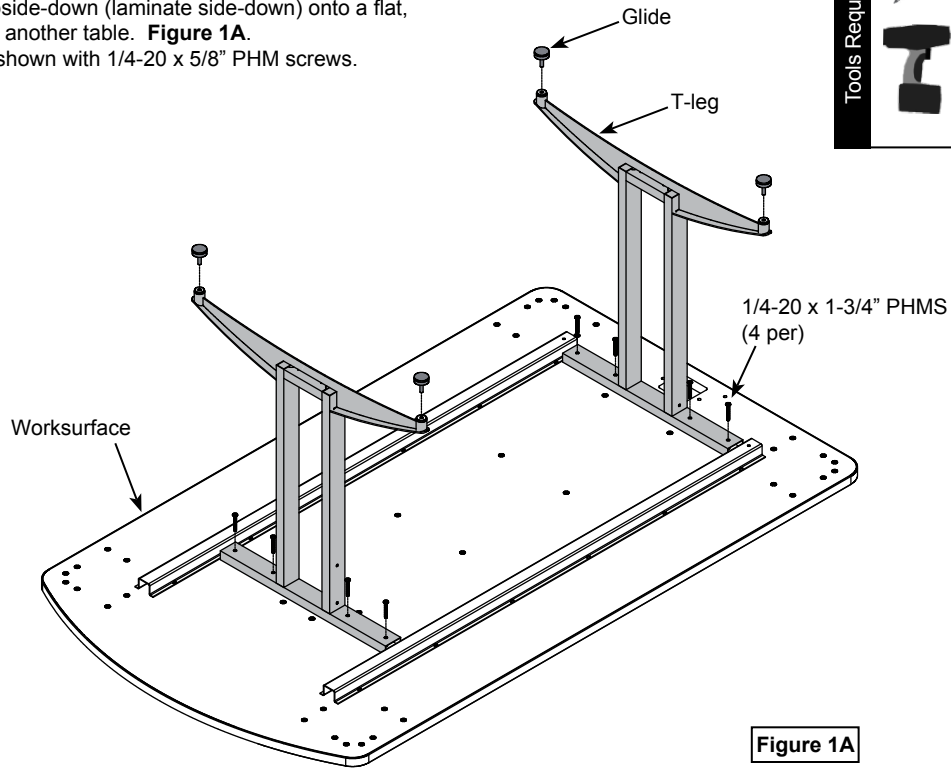

Tools Required

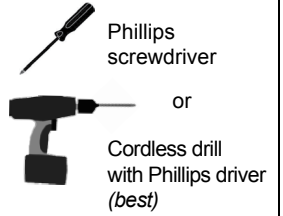

2. Attach cord channel to worksurface

1. Attach the left and right cord channels to the worksurface as shown with 1/4-20 x 5/8" PHM screws. **Figure 1B.**
2. Install the end cap with (2) 1/4-20 x 5/8" PHMS, and (2) 8-32 x 1/2" PH thread-cutting screws and tighten securely.

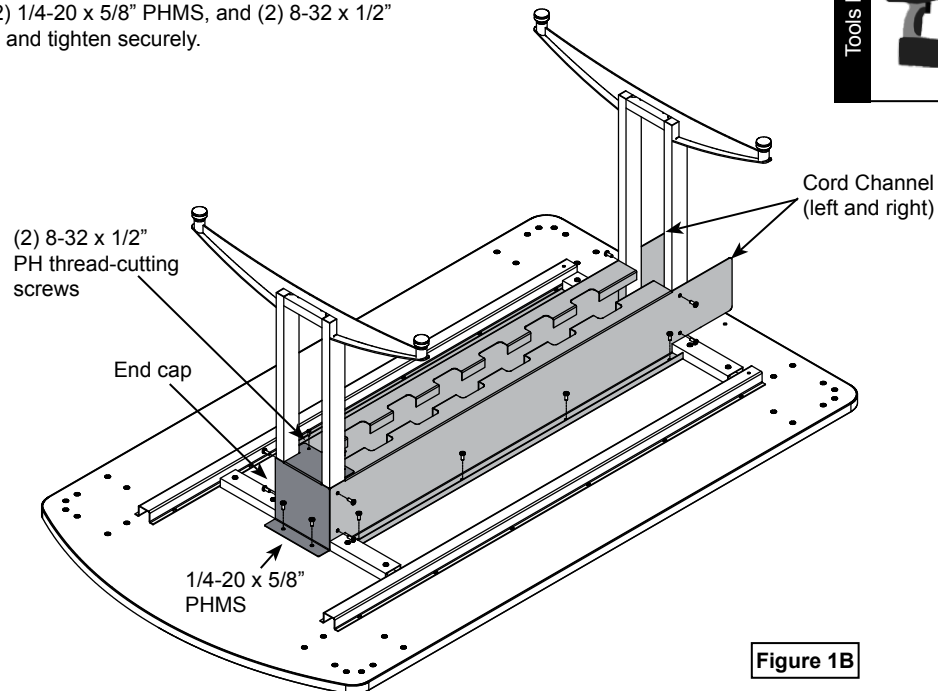

Tools Required

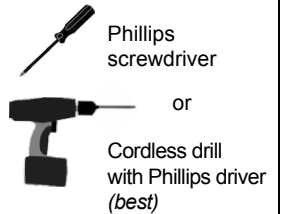

Assembly / Setup - Table with Post Legs

1. Attach Post legs to worksurface

1. Place the worksurface upside-down (laminated side-down) onto a flat, non-abrasive surface like another table. **Figure 2A.**
2. Attach each post leg as shown with (8) 1/4-20 x 5/8" PHM screws.
3. Install the four glides.

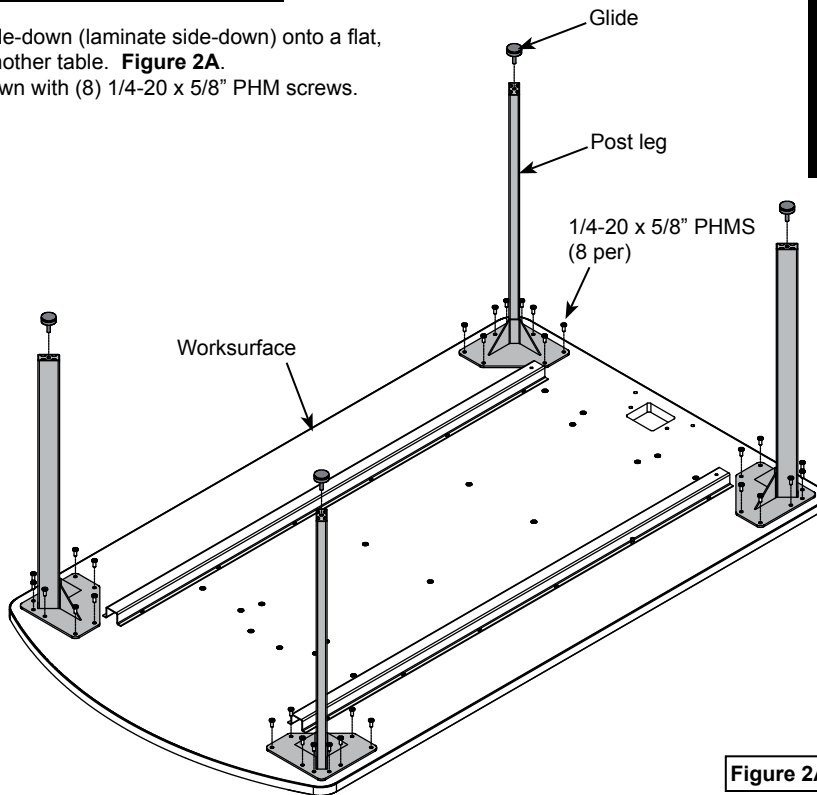
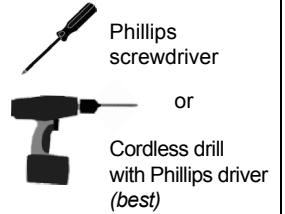

Figure 2A

Tools Required



2. Attach cord channel to worksurface

1. Attach the left and right cord channels to the worksurface as shown with 1/4-20 x 5/8" PHM screws. **Figure 2B.**
2. Install the end cap with (2) 1/4-20 x 5/8" PHMS, and (2) 8-32 x 1/2" PH thread-cutting screws and tighten securely.

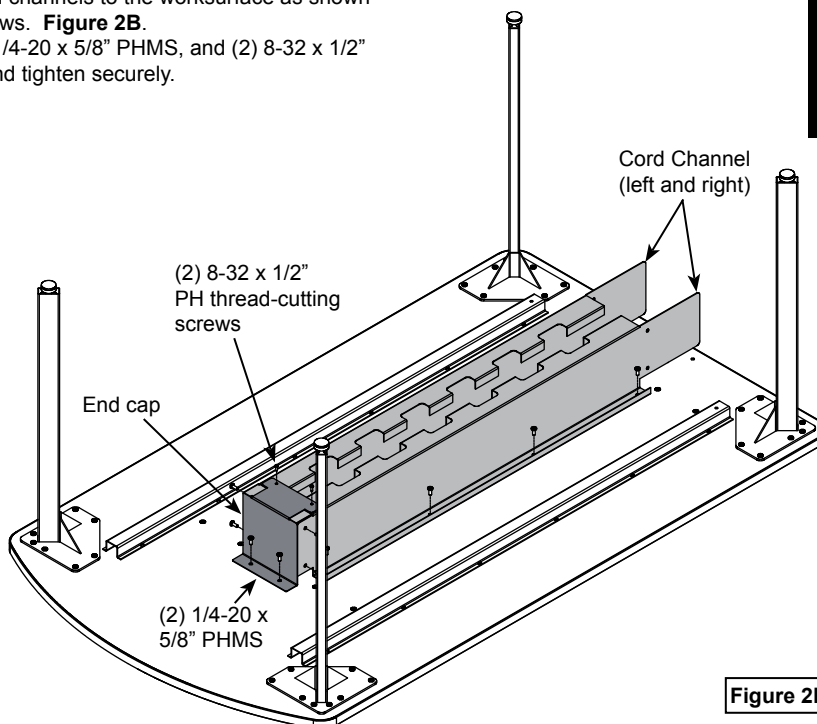
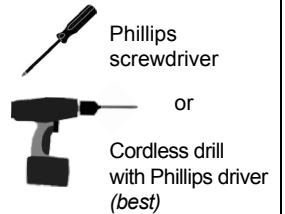

Figure 2B

Tools Required



3. Flip Table upright

1. Carefully flip the table upright-this will take 3-4 people. **Figure 3.**

CAUTION

Do not allow the legs to contact the floor until the table is completely rotated. Side-loading of the table legs could cause damage.

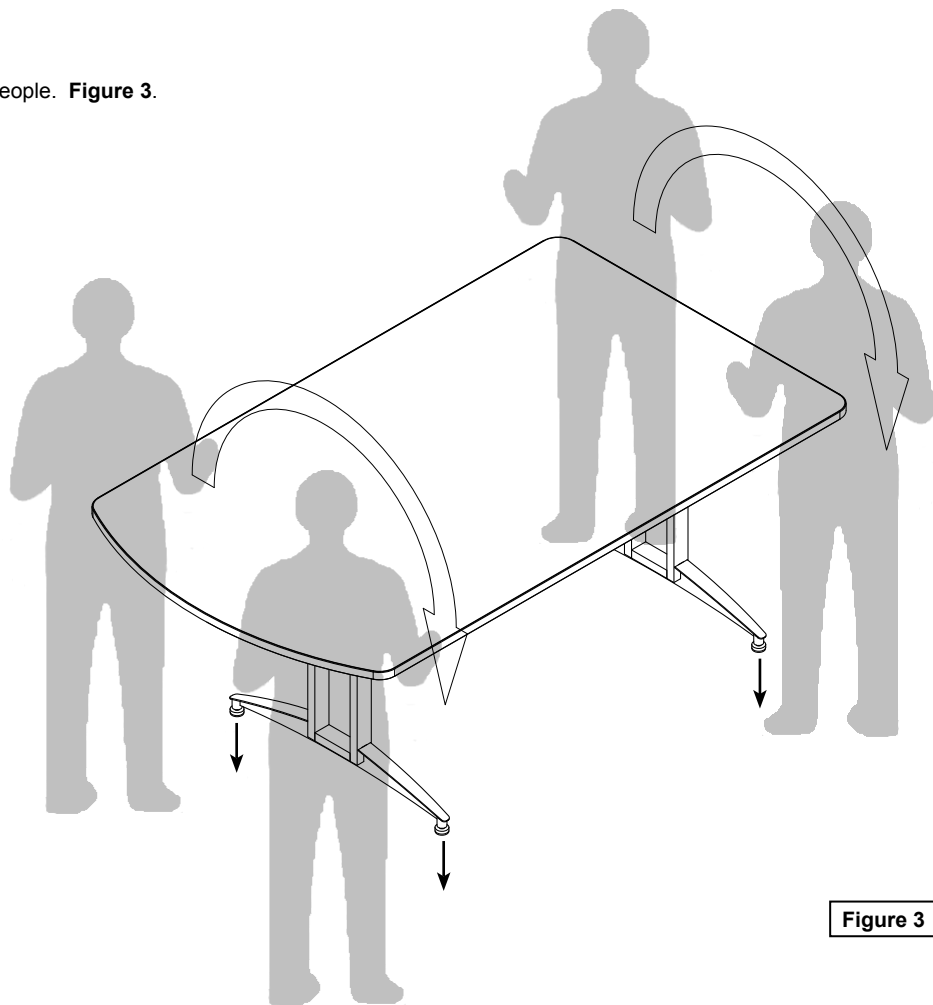

Figure 3

4. Display Stand

1. If you have the optional display stand, proceed with the installation at this time. **Figure 4.** (Instructions included with stand.)

5. Wiring

1. If your worksurface has optional power module or device cutouts, install the devices, then route and secure the cords using the wiring channel underneath. **Figure 4.**

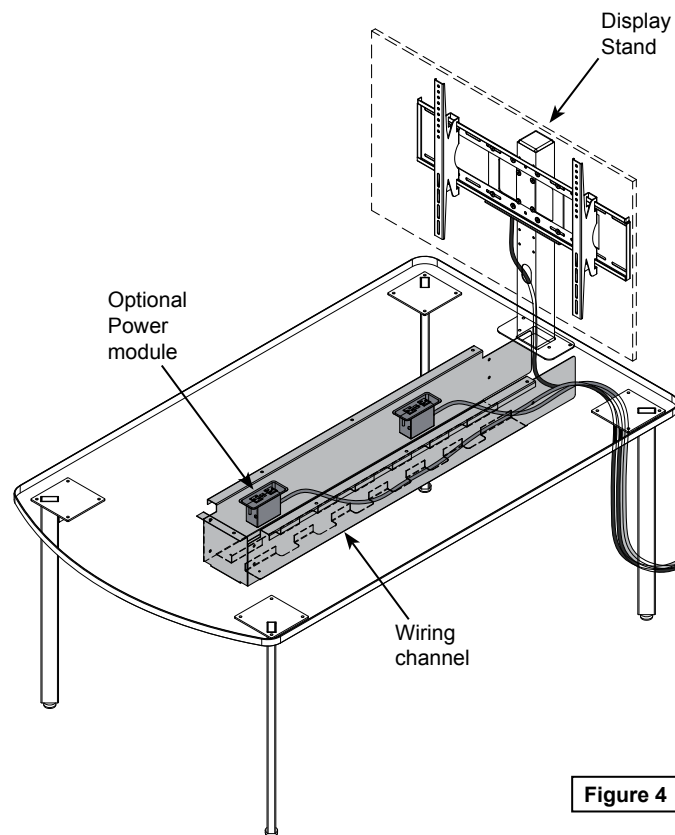
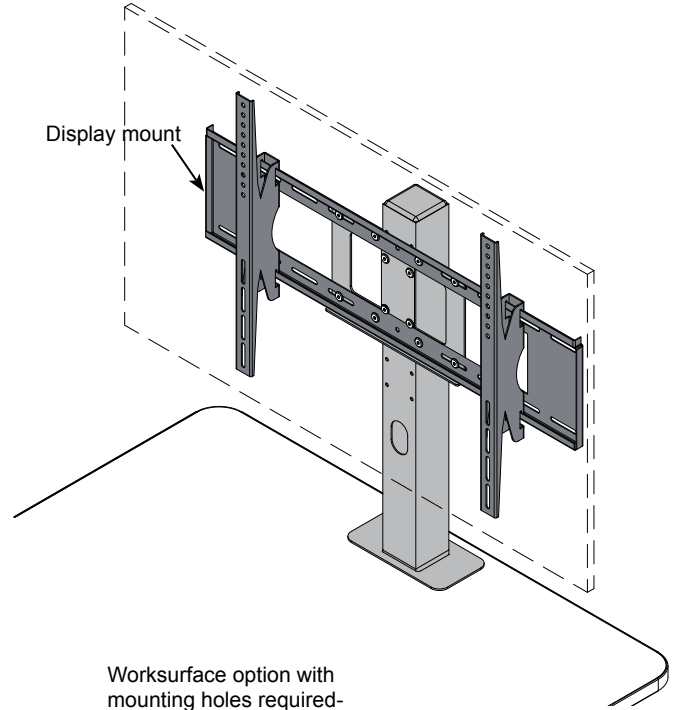

Figure 4

Element Display Stand - 37130

- Bolts directly to worksurface
- Integrated cable management routes and hides wires
- Adjustable (VESA-compatible) mount
- Requires worksurface mounting holes and cutout

Monitor size range:	32"-55" [81.3 cm-139.7 cm] diagonal
Weight capacity:	100 lb [45.4 kg]
Vertical adjustment (worksurface-to-center)	<ul style="list-style-type: none"> • 23.5"H [59.7 cm] • 21.5"H [54.6 cm] • 19.5"H [49.5 cm] • 17.5"H [44.5 cm] • 15.5"H [39.4 cm] (5 vertical positions in 2" increments)
Tilting	15° range
Shipping weight:	35 lb [15.9 kg]



Worksurface option with mounting holes required-specify when ordering

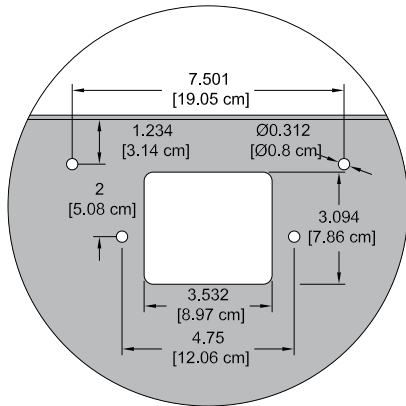

Mounting holes and cutouts needed on flat end of worksurface

Cove Power Module - 99044

- Two power receptacles per module
- Two USB charge ports (not data-compatible)
- Thumbscrew clamps
- Requires worksurface cutout
- ETL listed
- Available in Black or Silver

Cutout required:	5.25"W [13.3 cm] x 2"D [5.1 cm] (mounts to surface thicknesses up to 1.5")
Power cord:	9' [274 cm] with 90° flat plug with 45° rotation
Power receptacles:	12A, 120 VAC spill-resistant
USB charging ports:	2.1A (10.5W)
Dimensions:	6"W [15.2 cm] x 2.5"D [6.35 cm] x 3.18"H [8.1 cm]
Unit weight:	2.29 lb [1 kg]

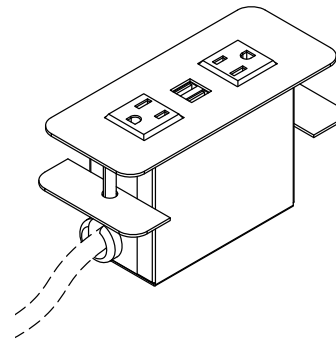

Worksurface option with mounting cutout required-specify when ordering



Warranty

WE WILL MAKE IT RIGHT FOR YOU!

Spectrum is committed to provide complete customer satisfaction. Each of our products is manufactured from the best materials available and each product is stringently monitored throughout the production process through our P.A.C.E. program (Product Assurance to meet Customer Expectations).

We expressly warrant that Spectrum products will be of good quality and workmanship and free from defect for the period set out in the warranty table below from the date of delivery. This warranty shall not apply to defects or damage resulting from misuse, abuse, neglect, improper care, modification or repair not authorized by Spectrum, or any other cause outside the control of Spectrum. Spectrum will, at its sole option, either repair or replace the defective product.

This warranty is exclusive; no other warranty, written or oral, is expressed or implied. This warranty is given by Spectrum to Buyer and to no other person or legal entity. No Spectrum dealer, distributor, agent or employee is authorized to make any modification or addition to this warranty.

NOTWITHSTANDING ANYTHING TO THE CONTRARY, SPECTRUM WILL NOT UNDER ANY CIRCUMSTANCES BE LIABLE FOR INDIRECT OR LIQUIDATED DAMAGES, INCLUDING CONSEQUENTIAL, INCIDENTAL AND SPECIAL DAMAGES. IN NO EVENT SHALL SPECTRUM'S LIABILITY, WHETHER UNDER CONTRACT OR WARRANTY, IN TORT OR OTHERWISE, EXCEED THE PURCHASE PRICE RECEIVED BY SPECTRUM FOR THE PRODUCT AT ISSUE AND "RECALL ACTION" EXPENSES. SPECTRUM SHALL NOT BE SUBJECT TO ANY OTHER OBLIGATIONS OR LIABILITIES, WHETHER ARISING OUT OF BREACH OF CONTRACT, WARRANTY, TORT (INCLUDING NEGLIGENCE AND STRICT LIABILITY) OR OTHER THEORIES OF LAW, WITH RESPECT TO PRODUCTS SOLD OR SERVICES RENDERED BY SPECTRUM, OR ANY UNDERTAKINGS, ACTS OR OMISSIONS RELATING THERETO.

Our Customer Service Department is ready to provide immediate attention to any questions, comments or concerns. They are available to answer your calls Monday through Friday from 7 am to 5 pm CST. In addition your product comments or concerns are welcome via e-mail at: spectrum@spectrumfurniture.com.

Warranty Table

effective 1/1/2015

Item	Warranty Period
Adjustable Crank / Electric Desk Legs	• 1 Year
Flat Panel Desk Gas Cylinders	
Chairs <ul style="list-style-type: none"> • Adjustable Height Chair Parts – including frames, gas cylinders, wood and plastic parts, control handles, casters • Adjustable Height Chair Upholstery • In-Stock Upholstery • Graded-In Fabrics and Customer Owned Material 	<ul style="list-style-type: none"> • 7 Years • 2 Years • 2 Years • No Warranty
Height Adjustable Columns and Lifts	• 1 Year
General Use Casters	
Electrical (including timers and LINAK actuators)	• 2 Years
Keyboard / Mouse Trays	• 1 Year
Flat Panel Monitor Arms <ul style="list-style-type: none"> • Flat Panel Monitor Arm – General Parts • Flat Panel Monitor Arm – Gas Cylinders 	<ul style="list-style-type: none"> • 5 Years • 2 Years
Desks and Lecterns <ul style="list-style-type: none"> • Computer Desk Chassis • Cart Chassis • Lectern Chassis 	• 10 Years

