

Assembly Instructions:

To purchase parts or accessories, please contact us at
www.spectrumfurniture.com
 1-800-235-1262
 Thank you for choosing Spectrum products!

Before you begin, please make sure all parts and proper quantities are included. Any parts damaged during shipment must be reported within 15 days of receipt. To report information regarding damages or if you have any questions, please call 1-800-235-1262.

Note: The items below represent all the structural components available for the Instructor Media Console. Due to the console configurations and various order combinations available, some of the items shown here may not be included with your particular unit-some assembly steps may not apply. Before beginning assembly, please review these instructions.

Assembly Tips:

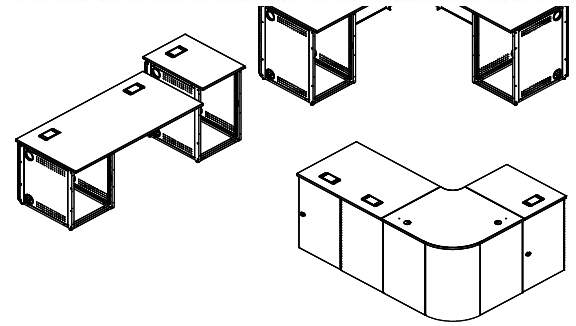

- Assemble the console in its final location.
- To facilitate assembly, keep the fasteners finger-tight until the console is completely together. Then tighten securely.







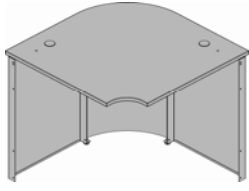
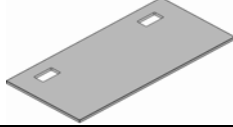
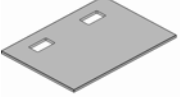



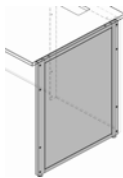



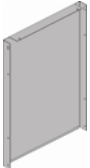

Instructor Media Console 68000 series

Tools Required:
 4mm hex wrench (included)
 Glide wrench (included where applicable)



	Product #	Description	Parts Bag Items
	68156	36" Radius Corner	(26) 1/4-20 x 15mm JC bolt - 052605 (14) 1/4-20 Locknut - 041943 (2) 1/4-20 x 50mm JC bolt - 038047 (2) Glide 5/16-18 x 1-5/8" - 025068 (2) Unit-to-Unit bracket - 037749 (2) Work surface bracket - 044069 (3) Cord Clip - 051112 (1) 4mm Hex wrench - 025039 (1) Glide wrench - 025069
	68106	29" Radius Corner	(2) 1/4-20 x 15mm JC bolt - 052605 (2) Unit-to-Unit bracket - 037749 (1) 4mm Hex wrench - 025039 (4) #6 x 5/8" PHSM screws - 025044
	68202	Triple Work Surface	(4) 1/4-20 x 15mm JC bolt - 052605 (2) Unit-to-Unit bracket - 037749 (1) 4mm Hex wrench - 025039 (4) #6 x 5/8" PHSM screws - 025044
	68201	Double Work Surface	(4) 1/4-20 x 15mm JC bolt - 052605 (2) Unit-to-Unit Bracket - 037749 (1) 4mm Hex wrench - 025039 (4) #6 x 5/8" PHSM screws - 025044
	68200	Single Work Surface	(4) 1/4-20 x 15mm JC bolt - 052605 (2) Unit-to-Unit Bracket - 037749 (1) 4mm Hex wrench - 025039 (4) #6 x 5/8" PHSM screws - 025044
	68157	36" Equipment Rack	(4) 1/4-20 x 15mm JC bolt - 052605 (2) Adhesive bumper - 044573 (4) Glide 5/16-18 x 1-5/8" - 025068 (1) 1/4-20 x 90mm JC bolt - 039065
	68107	29" Equipment Rack	(1) 1/4-20 Locknut - 041943 (1) 4mm Hex wrench - 025039 (1) Glide wrench - 025069

	Product #	Description	Parts Bag Items
	68155	36" End-Support Leg	 (2) Glide 5/16-18 x 1-5/8" - 025068  (2) 1/4-20 x 40mm JC bolt - 021581  (1) 4mm Hex wrench - 025039  (1) Glide wrench - 025069
	68105	29" End-Support Leg	
	68151	36" Wall Filler Panel	 (10) 1/4-20 x 15mm JC bolt - 052605  (4) 1/4-20 Locknut - 041943  (1) 4mm Hex wrench - 025039  (2) Cord Clip - 051112
	68101	29" Wall Filler Panel	
	68154	36" Mid-Support Leg	 (4) 1/4-20 x 15mm JC bolt - 052605  (2) Glide 5/16-18 x 1-5/8" - 025068  (1) 4mm Hex wrench - 025039  (1) Glide wrench - 025069
	68104	29" Mid-Support Leg	

Work surface support guidelines

To provide adequate support, areas under work surfaces generally should not exceed a span of more than two open spaces (wall filler panels) wide.

When a radius corner is used with two double work surfaces that have equipment rack support, a mid-support leg usually is not necessary.

When a radius corner is next to a double work surface, an equipment rack or mid-support leg should be used to support the double work surface.

When a triple work surface is specified, at least one equipment rack should be used underneath to provide adequate support.

Mid-support legs are used at the joint connection of two work surfaces.

End-support legs are used at the end of a work surface.

1. Radius Corner Assembly

- A. Install the (2) glides onto the corner panel. **Figure 1A.** The glides can be adjusted later to level the console.
- B. Attach each wall filler panel to the corner panel with (4) 1/4-20 x 15mm JC bolts and (4) 1/4-20 locknuts.
- C. Align and attach the corner work surface to the wall filler panels with (4) 1/4-20 x 15mm JC bolts. **Figure 1B.**

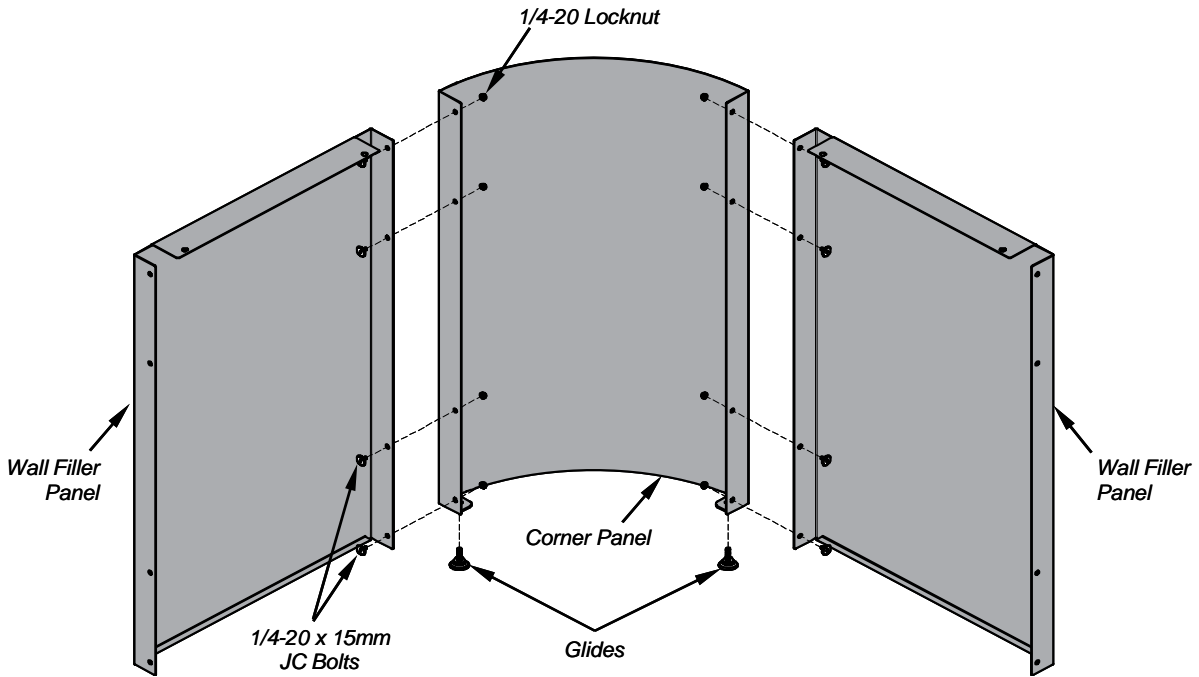

Figure 1A

Note: Do not tighten fasteners completely until the unit is together.

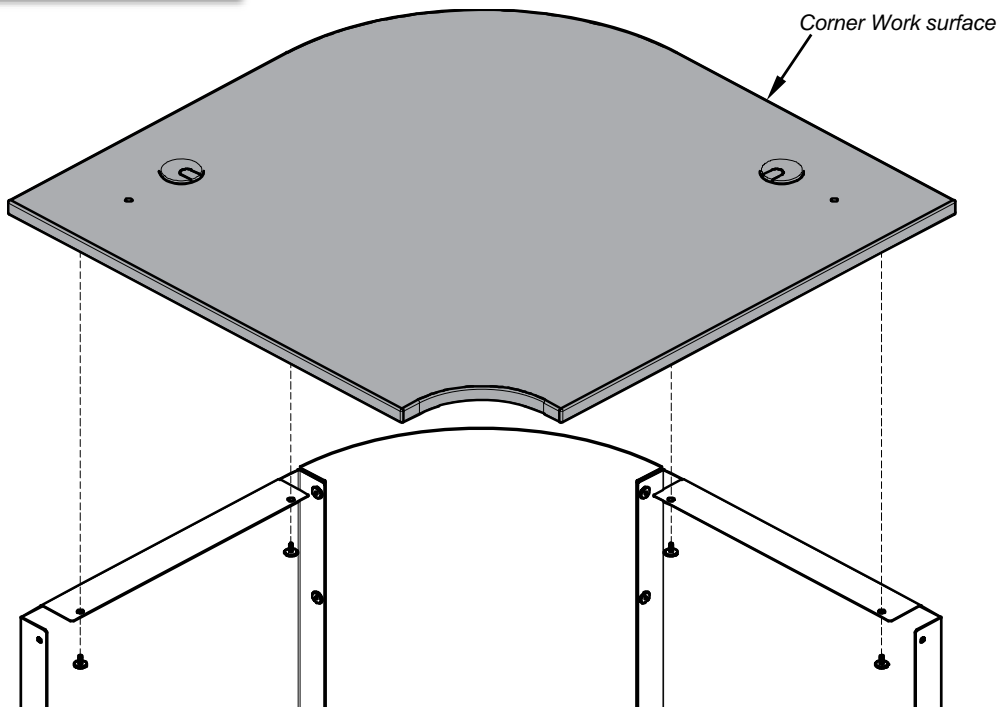

Figure 1B

2. Equipment Rack Assembly

- Tip the equipment rack onto its back.
- Install the (4) glides onto the bottom as shown. **Figure 2A.** The glides can be adjusted later to level the console.
- Tip the unit back upright, and open the rear door to attach the (2) adhesive bumpers to the equipment rack frame as shown. **Figure 2B.**

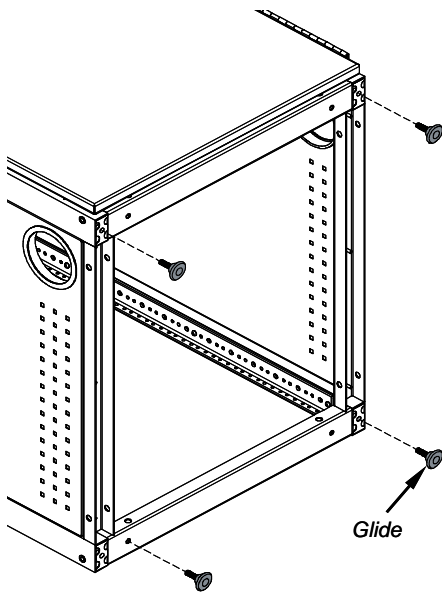

Figure 2A

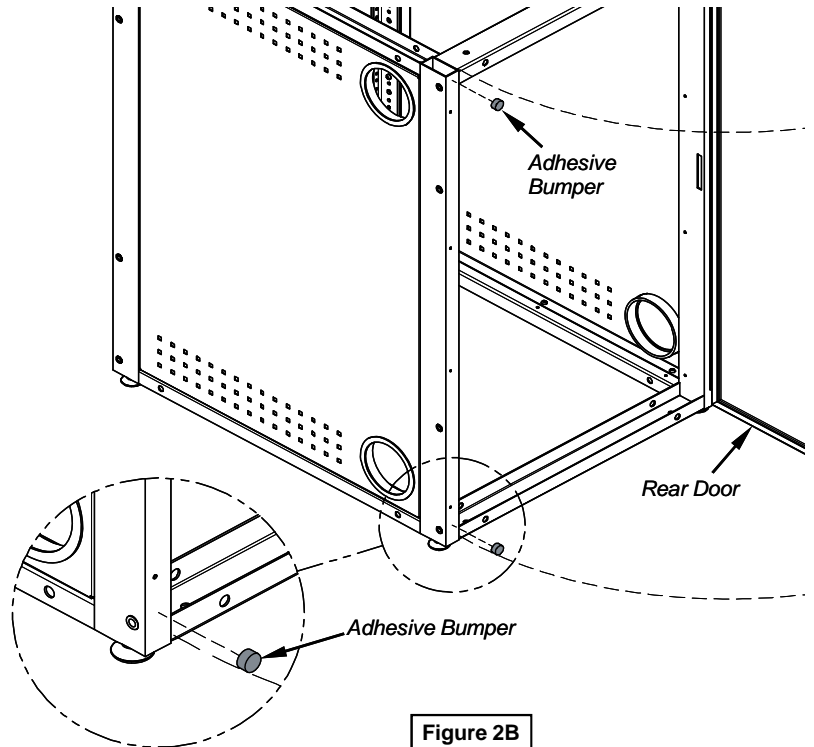

Figure 2B

3. Wall Filler Panel Assembly

Panel-to-Equipment Rack attachment:

- Align the wall filler panel mounting holes as shown. **Figure 3A.**
- Attach with (4) 1/4-20 x 15mm JC bolts. (Locknuts are not required.)

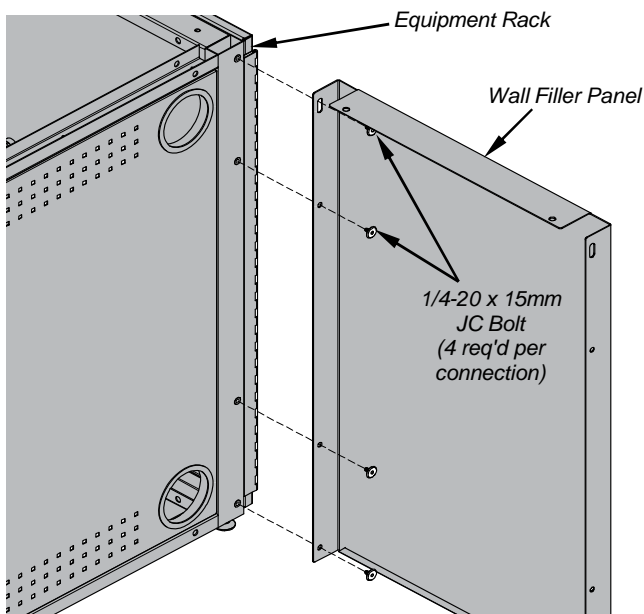

Figure 3A

Panel-to-Panel attachment:

- To attach two wall filler panels together, align the mounting holes.
- Attach together with (4) 1/4-20 x 15mm JC bolts and (4) 1/4-20 locknuts. **Figure 3B.**

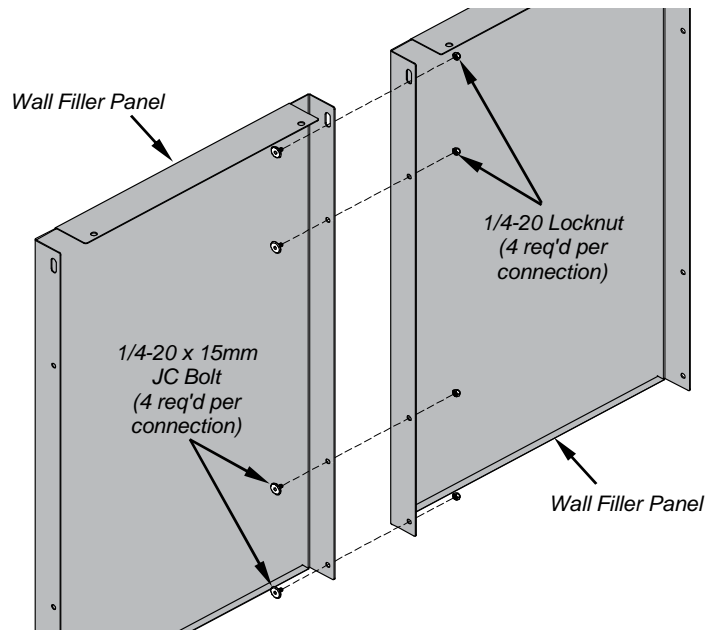

Figure 3B

4. End-Support Leg Assembly

- Install the (2) glides onto the bottom of the leg. The glides can be adjusted later to level the console.
- Align the end-support leg and wall filler panel mounting holes.
Be sure the wall filler panel overlaps the end-support leg as shown. Figure 4.
- Attach with (4) 1/4-20 x 15mm JC bolts.

Note: End-support legs are used at the end of work surfaces only. The end-support leg is symmetrical and can be installed on the left or right side of the console.

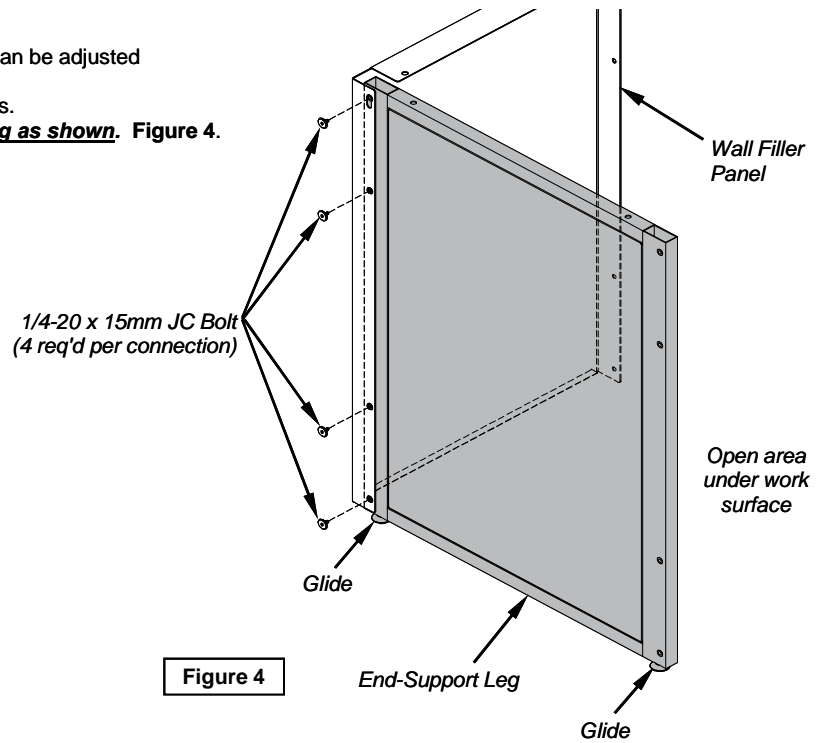
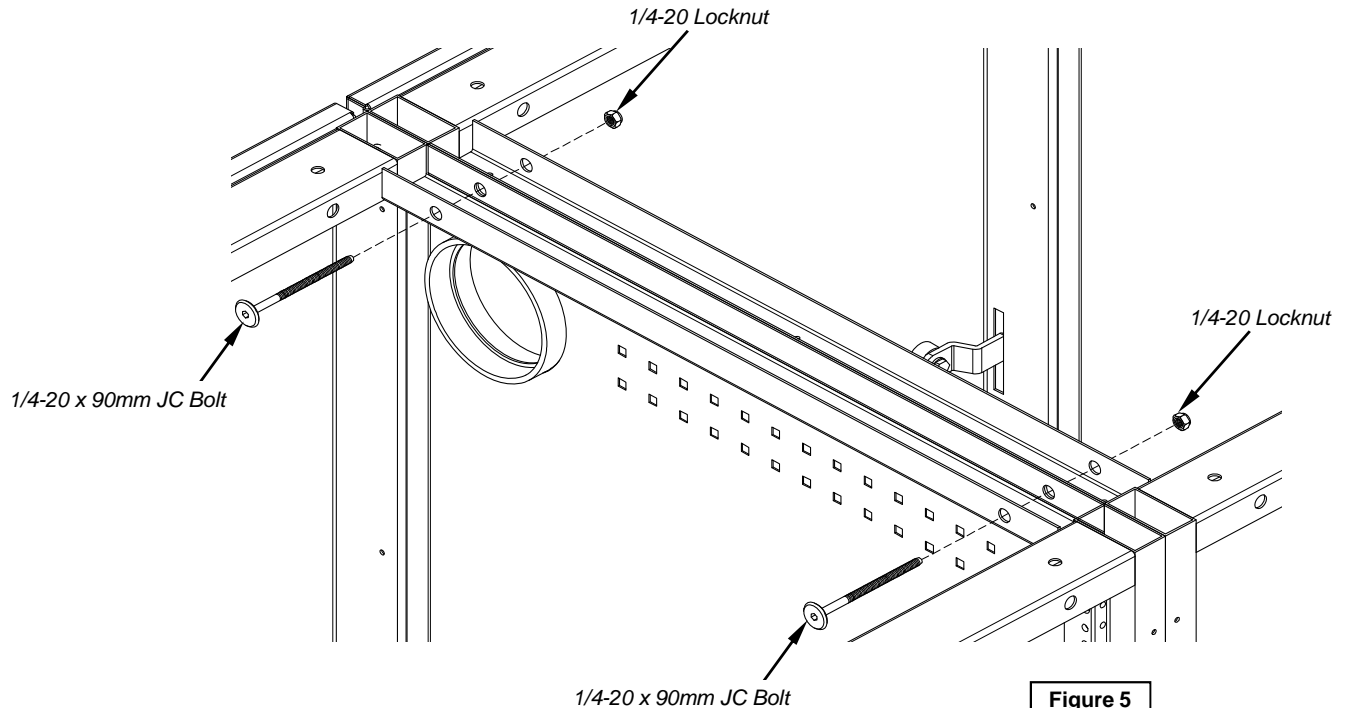

Figure 4

5. Equipment Rack-to-Equipment Rack Connection

- Place the two equipment racks together as shown. Figure 5.
- Install (2) 1/4-20 x 90mm JC bolts and (2) 1/4-20 locknuts.
- Do not over-tighten fasteners.



6. Mid-Support Leg Assembly

- Install the (2) glides onto the bottom of the leg. The glides can be adjusted later to level the console.
- Align the mid-support leg and wall filler panel mounting holes as shown in **Figure 6**.
- Attach the mid-support leg to the wall filler panels with (4) 1/4-20 x 15mm JC bolts.
- Set both work surfaces onto the console with the seam centered over the mid-support leg.
- Attach to work surfaces with (4) 1/4-20 x 15mm JC bolts

Note: Mid-support legs are used at the joint connection of two work surfaces to provide support for two or more open spaces (wall filler panels) wide.

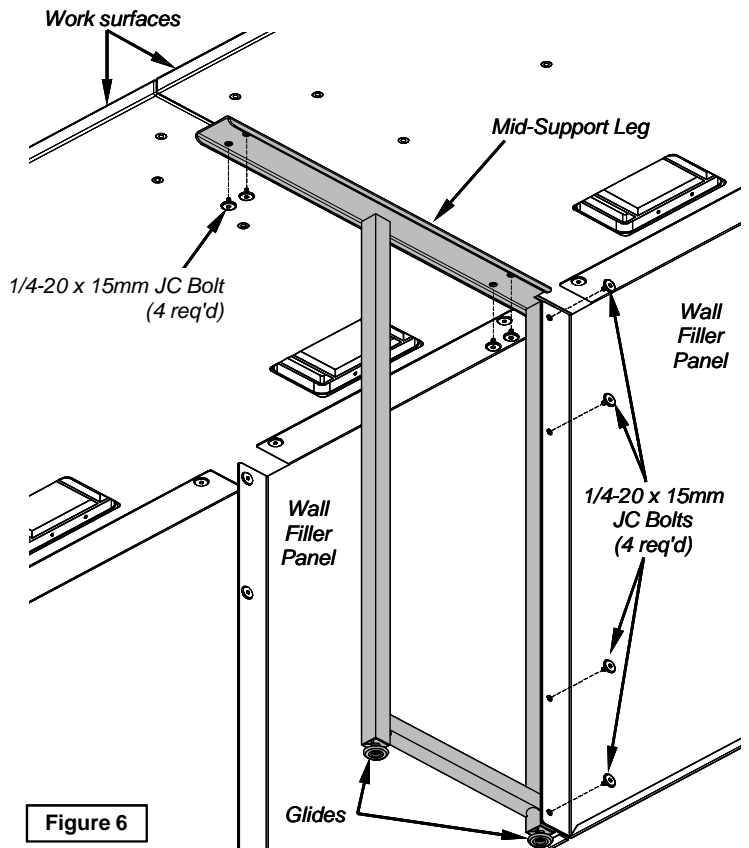

Figure 6

7. Work surface Assembly

Work surface-to-Work surface connection:

- Attach the (2) unit-to-unit brackets to one installed work surface (use inner holes) with 1/4-20 x 15mm JC bolts. Do not tighten completely. **Figure 7A**.
- Set the second work surface onto the unit-to-unit brackets, and adjacent assembled wall filler panels.
- Align the work surface mounting holes with the wall filler panel mounting holes.
- Attach with 1/4-20 x 15mm JC bolts.

Note: This is the connection between two work surfaces with open area underneath (no equipment racks). To provide adequate support, areas under work surfaces generally should not exceed a span of more than two open spaces (wall filler panels) wide.

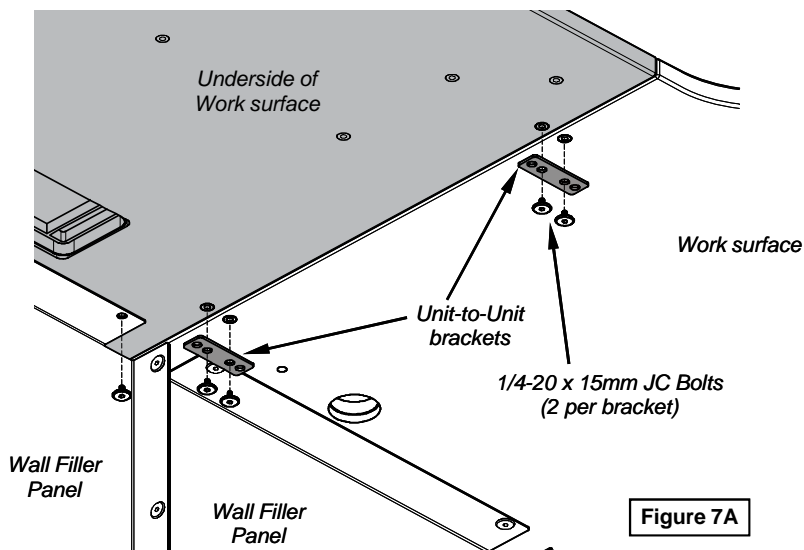

Figure 7A

Work surface-to-top of Equipment Rack:

Note: This is the attachment of a work surface to the top of an equipment rack.

- Set the work surface onto the equipment rack and any adjacent assembled wall filler panels (if applicable). **Figure 7B.**
- Align the work surface and equipment rack mounting holes.
- Attach work surface with (4) 1/4-20 x 15mm JC bolts.

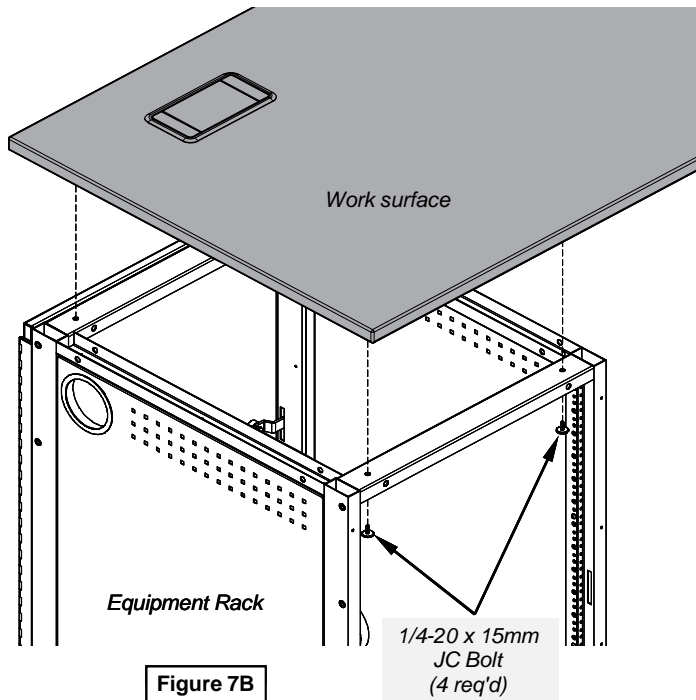

Figure 7B

Work surface-to-Work surface with Equipment Rack:

Note: This is the connection between a work surface and work surface on top of an equipment rack.

- Attach each work surface bracket to the equipment rack with (1) 1/4-20 x 50mm JC bolt and (1) 1/4-20 locknut (attached from inside eq rack). (The slotted side of the bracket will attach to the work surface.) Do not tighten completely. **Figure 7C.**
- Set the work surface onto the assembled wall filler panel(s) and work surface brackets and align the mounting holes.
- Attach work surface with 1/4-20 x 15mm JC bolts.

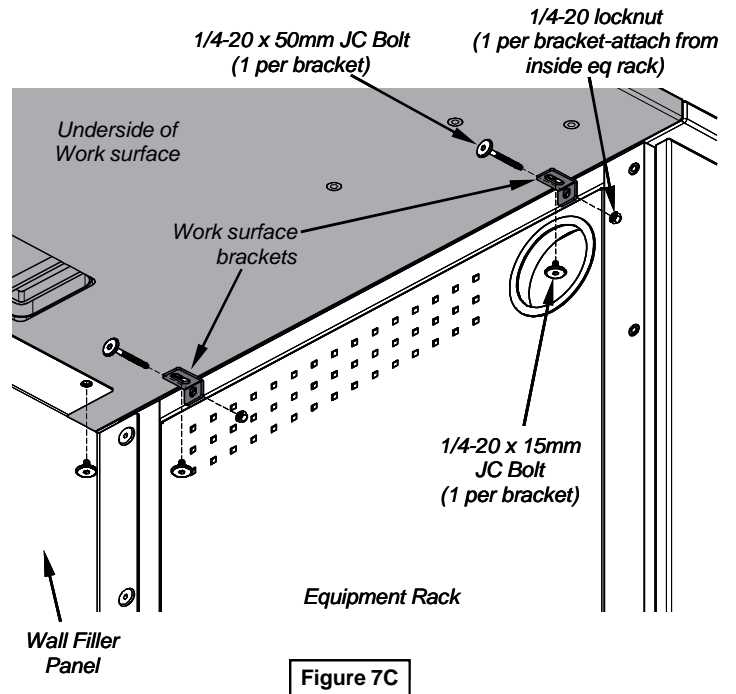

Figure 7C

8. Grommets & Cord Clips

- Remove the entire grommet assembly from the work surface.
- Remove the center cover and slide out the cord receptacles. **Figure 8A.**
- Turn the receptacles around to access the cord pass-through holes and slide back into the grommet frame around the cord(s). **Figure 8B.**
- Re-install the grommet assembly into the work surface cut-out and replace the center cover. **Figure 8C.** Optional: Install (2) #6 x 5/8" PHSM screws through the side to secure grommet to the work surface.
- Apply cord clips to underside of work surface where needed to route cords. **Figure 8D.** (Included with radius corner and wall filler panels only.)

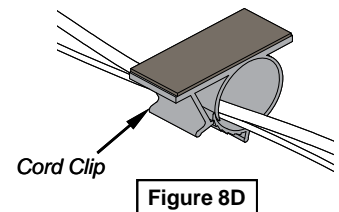

Figure 8D

Note: The grommets and cord clips provide cord management when cords and wires are to be routed to the work surface from under the console.

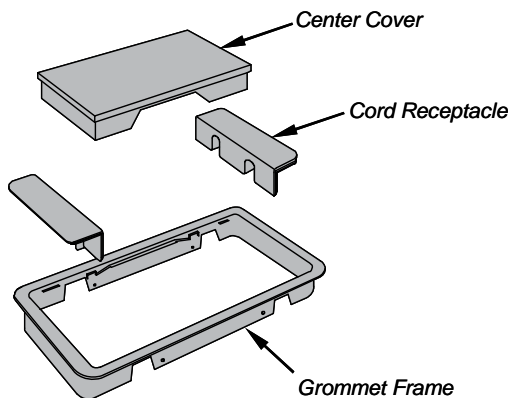

Figure 8A

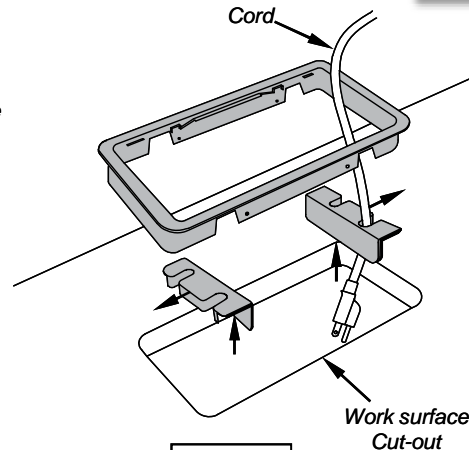

Figure 8B

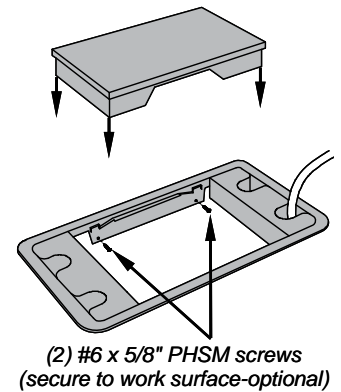
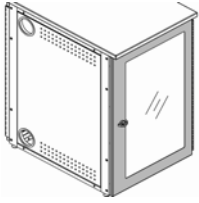
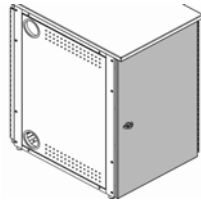

Figure 8C

Instructor Media Console Options



Clear Acrylic Locking Door
68153 - 36"H
68103 - 29"H



Solid Locking Door
68152 - 36"H
68102 - 29"H

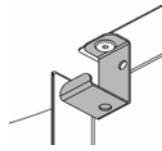

Wire Management Clips
mount under work surface
(set of three)
68206

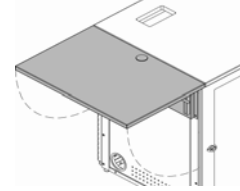

Side Flip-Up Shelf
21-3/16"W x 30"D
150 lb max load
(not recommended for use on
stand-alone equipment racks
with single work surfaces)
68204

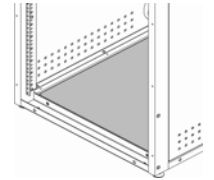

Equipment Rack Bottom Shelf
(increases security &
prevents static electricity &
dust build-up)
68203

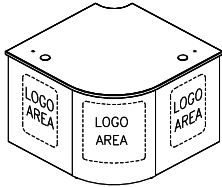

Custom-Cut Logo
(Typical logo location shown
on wall filler panels)
55141



Adjustable Drafting Stool
38202



Multi-functional Stool
38245

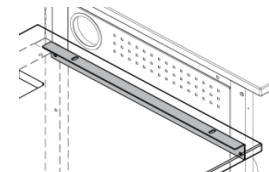

Stepped-Height Bracket
(connects 29"H console to 36" console)
68205

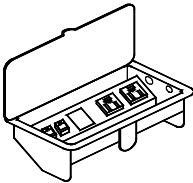

Power/Communication Module
w/9' power cord, two outlets, two data jacks
7 1/8"W x 3 5/8"D
99003 (w/out mic jack)

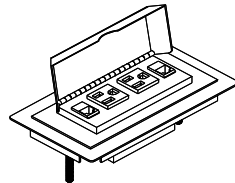

UL-Listed Power/Communication Module
w/9' power cord, two outlets, two
data jacks, and adapter plate
7 1/8"W x 3 5/8"D x 3/4"H
99028



Rear Rack Rail Kit
set of two, adds 18RU or 14RU
to rear of equipment rack
68150 - 36"H (18RU)
68100 - 29"H (14RU)

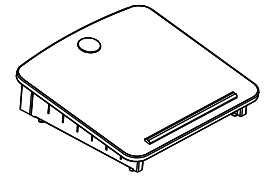

Riser Podium
18"W x 17 13/16"D
95002

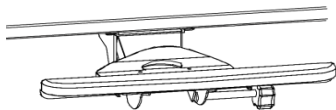

Adjustable Econo Keyboard Tray
18 3/8"W x 12"D
95520

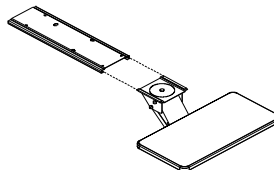

Micro-arm Keyboard Tray
moves in, out, up & down
19 3/4"W x 10"D
95506

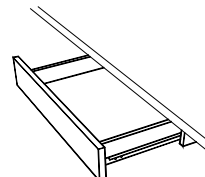

3" Pencil Drawer
18"W x 11"D x 3"H
(Mounts under work surface or
inside equipment rack)
97500

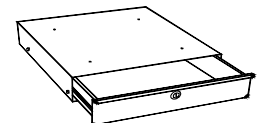

Universal Laptop Drawer
16"W x 17 1/2"D x 3 1/2"H
95510

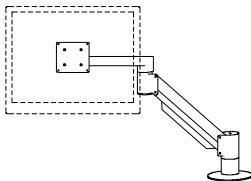

Flat Panel Monitor Arm
95512 (for monitors weighing 4-11.5 lbs)
95522 (for monitors weighing 10-27.5 lbs)
95509 (for monitors weighing 14-31 lbs)

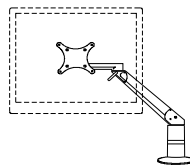

Evo Flat Panel Monitor Arm
95523 (for 15"-19" monitors weighing 6-13 lbs)
95524 (for 19"-21" monitors weighing 13-21 lbs)

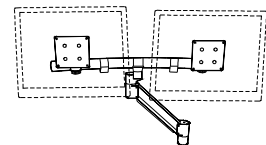

Dual Flat Panel Monitor Arm
(23" max center-to-center distance)
(4-19 lbs per monitor)
95516

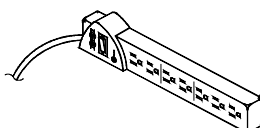

7-Outlet Power Strip, insured
w/surge protector, bracket, and 12' cord
10"W x 2"D x 1 1/8"H
99024

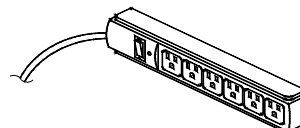

6-Outlet Power Strip
w/ 12' cord
11 5/16"W x 1 1/16"D x 1 3/16"H
99023

Rack-mount accessories

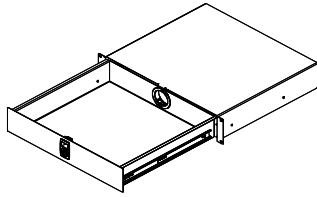

Locking Drawer (2RU)
 interior dims: 15³/₄"W x 13¹/₁₆"D x 2⁷/₈"H
 (25 lbs max load)
 97514

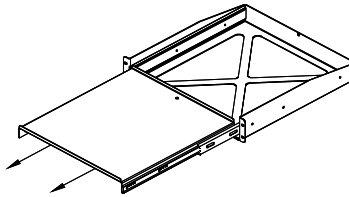

Pull-Out Shelf (2RU)
 16¹/₂"W x 17³/₄"D
 (50 lbs max load)
 97505

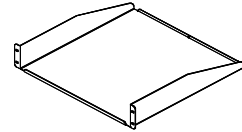

Cantilever Shelf (2RU)
 17¹/₂"W x 18"D x 3¹/₂"H
 (50 lbs max load)
 97504

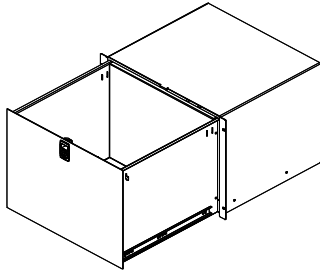

Locking File Drawer (8RU)
 includes file holder
 interior dims: 15³/₄"W x 13⁹/₁₆"D x 13⁵/₁₆"H
 (50 lbs max load)
 97515

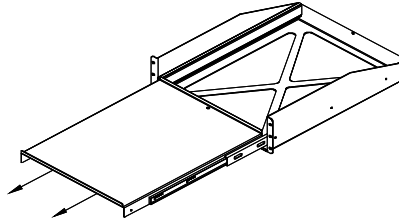

Pull-Out Shelf (3RU)
 16¹/₂"W x 21³/₄"D
 (80 lbs max load)
 97503

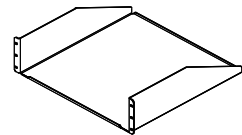

Cantilever Shelf (3RU)
 17¹/₂"W x 18"D x 5¹/₄"H
 (80 lbs max load)
 97502

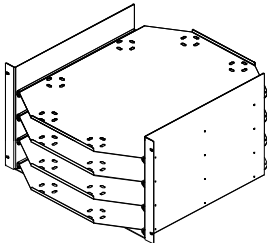

LT-4 Laptop Storage Unit (7RU)
 (stores 4 laptops horizontally)
 laptop tray dims:
 16¹/₄"W x 20¹/₂"D x 2³/₁₆"H
 97517

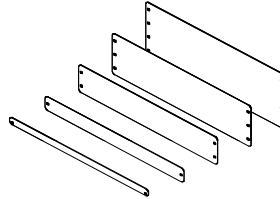

Rack-Mount Blanks
 (fills rack spaces where
 components are not needed)
 97516 - (1/2RU)
 97510 - (1RU)
 97511 - (2RU)
 97512 - (3RU)
 97513 - (4RU)

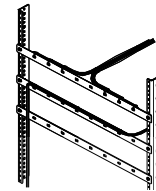

Wire Lace Kit
 3 lace straps included
 95517

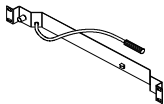

Flexible Halogen Light (1RU)
 19"W x 2"D x 1³/₄"H
 99033

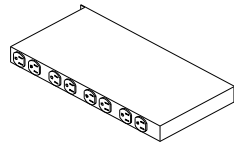

9-Outlet Power Strip (1RU)
 19"W x 9"D x 1³/₄"H
 99021

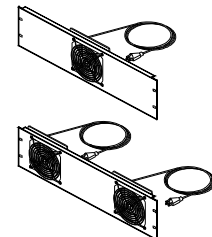

Cooling Fans (3RU)
 19"W x 2"D x 5¹/₄"H
 Single Fan-97507
 Double Fan-97506

Warranty

WE WILL MAKE IT RIGHT FOR YOU!

We guarantee all Spectrum products to be free of all defects in materials and workmanship, for the original owner, for a period of **ten years**. Any item deemed defective by Spectrum or the original manufacturer, under normal use conditions, will be repaired or replaced at Spectrum's discretion. This warranty applies to all products manufactured and distributed by Spectrum except the products listed below.

DESIGNED FOR INDOOR USE ONLY - Spectrum's products have been designed and constructed for indoor use only. Moving or using outdoors, or on excessively rough surfaces, may cause damage to the products and may void the warranty. If an outdoor application is desired please contact us to discuss potential custom design solutions.

Spectrum is committed to provide complete customer satisfaction. Each of our products are manufactured from the best materials available and each product is stringently monitored throughout the production process through our P.A.C.E. program (Product Assurance to meet Customer Expectations).

Our Customer Service Help Line 1-800-235-1262 is ready to provide immediate attention to any questions, comments or concerns. We are available to answer your calls Monday through Friday from 7 am to 5 pm CST. In addition your product comments or concerns are welcome via e-mail at: spectrum@spectrumfurniture.com.

Items that have a varying warranty include, but are not limited to, the following:

- Adjustable Crank/Electric Desk Legs (1 yr)
- Flat Panel Desk Gas Cylinders (1 yr)
- Adjustable Height Chair Parts – including frames, gas cylinders, wood and plastic parts, and control handles (7 yrs)
- Adjustable Height Chair Parts Casters (2 yrs)
- Adjustable Height Chair Upholstery - In-Stock Upholstery (2 yrs)
- Adjustable Height Chair Upholstery - Graded-In Fabrics and C.O.M (no warranty)
- Height Adjustable Columns and Lifts (1 yr)
- General Use Casters (1 yr)
- Electrical – ECA (1 yr)
- Electrical - Power Strips (1 yr)
- Electrical Surge Suppressors (lifetime)
- Electrical - Retractable Power Cords (1 yr)
- Keyboard/Mouse Trays (1 yr)
- Flat Panel Monitor Arm – General Parts (5 yrs)
- Flat Panel Monitor Arm – Gas Cylinders (2 yrs)
- CRT Monitor Arm (1 yr)

The warranty, as stated above, is effective as of 05/28/2009

Touchboards

205 Westwood Ave, Long Branch, NJ 07740
Phone: 866-94 BOARDS (26273) / (732)-222-1511
Fax: (732)-222-7088 | E-mail: sales@touchboards.com



SCIENTIFIC CERTIFICATION SYSTEMS
SCS-IAQ-02353



SPECTRUM
INDUSTRIES INC.

925 First Avenue, PO Box 400, Chippewa Falls, WI 54729 Ph: 1-800-235-1262 Fax: 1-800-335-0473

E-mail: spectrum@spectrumfurniture.com web: www.spectrumfurniture.com