

Standard Adapters

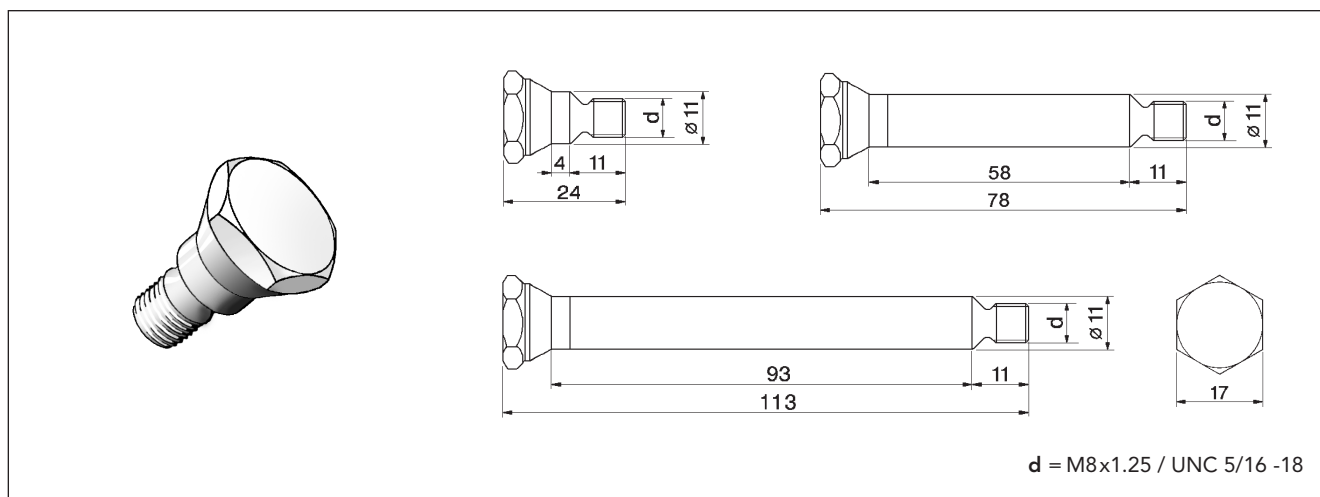

Adapters are solid bolts which are mounted in countersunk and threaded holes in the bearing housings. They form the connecting points for a transducer with quick connector, TRA-30 and equivalent.

Standard adapters are available in three lengths and various thread sizes, see part numbers below. The material is either stainless steel or zinc-plated steel.

Part numbers

The following types of adapters are available:

32000	Zinc-plated, M8 x 1.25, 24 mm
32100	Zinc-plated, M8 x 1.25, 78 mm
32200	Zinc-plated, M8 x 1.25, 113 mm
33000	Zinc-plated, UNC 5/16 -18, 24 mm
33200	Zinc-plated, UNC 5/16 -18, 113 mm
32010	Stainless steel, M8 x 1.25, 24 mm
32110	Stainless steel, M8 x 1.25, 78 mm
32210	Stainless steel, M8 x 1.25, 113 mm
33010	Stainless steel, UNC 5/16 -18, 24 mm
CAP-02	Dust cap for adapters

Technical data

Material, stainless steel	SS2346, AISI303 (EN:1.4305)
Material, zinc-plated	12 μ m Zn
Torque	15 Nm

Mounting tools

82053	Countersink with fixed pilot for M8
81027	Holder for countersink
81028	Countersink, angle 90°, \varnothing 12 mm
81031	Pilot for M8
81032	Pilot for UNC 5/16"

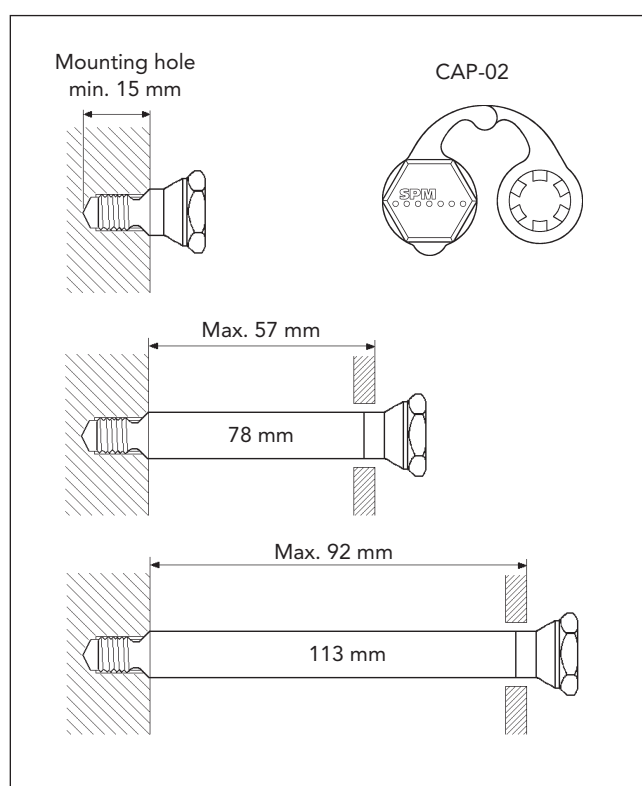

To drill the mounting hole, use drill bits:

6.9 mm	for M8
6.6 mm	for UNC 5/16"

Torque the adapter with a torque wrench and a 17 mm socket (SPM 81086).

