

SURFACE GAGES

56 SMALL SURFACE GAGES

(HARDENED STEEL BASE)

- Smaller base and spindle than other surface gages and is designed for lighter work
- Two frictionally held gage pins in the hardened steel base which can be pushed down and used against the edge of a surface plate or T-slot for linear work
- Weighs only ten ounces (0.28kg.) and takes up very little space in a toolbox
- Only 1-3/8" (35mm) high, including the lower sleeve in the rocker arm
- Scriber has a 3/32" (2.4mm) diameter and is 3-1/4" (82mm) long



56 Small Surface Gages					
Cat. No.	EDP	Spindle		Base	
		in	mm	in	mm
56A	50289	4	100	2 x 1-1/2	50 x 38
56B	50290	Two, 4 and 7	100 and 175		
56C	50291	7	175		

57 FULL-SIZED SURFACE GAGES

(CAST IRON BASE)

- Full-size surface gage with attractive finish
- Base is ground flat with two frictionally held gage pins that can be pushed down and referenced against the edge of a surface plate or T-slot for linear work

257 FULL-SIZED SURFACE GAGES

(HARDENED STEEL BASE)

- Finest full-size surface gage
- Stable steel base is fully hardened, ground and nicely finished
- Four frictionally held gage pins that add versatility for referencing the tool

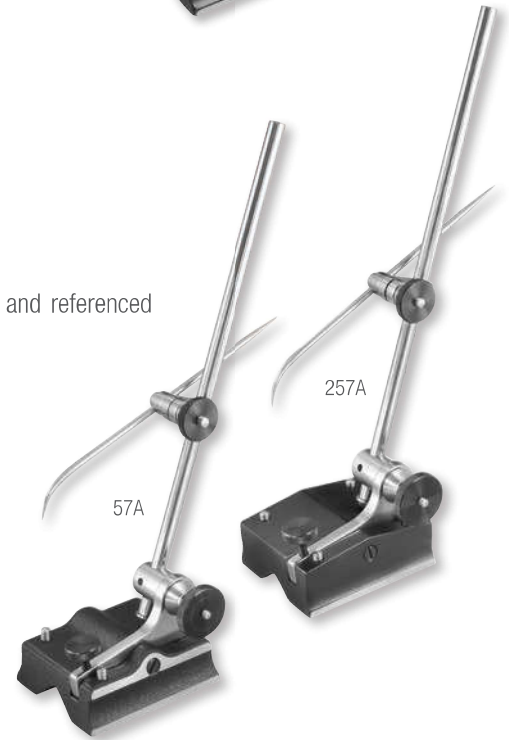

57 Full-sized Surface Gages			
Cat. No.	EDP	Spindle Length	Base - Length x Width
57A	50292	9" (225mm)	3 x 2-9/16" (75 x 65mm)
57B	50293	9" and 12" (225 and 300mm)	
57C	50294	12" (300mm)	3-3/4 x 3-3/8" (95 x 85mm)
57D	50295	12" and 18" (300 and 450mm)	

257 Full-sized Surface Gages			
Cat. No.	EDP	Spindle Length	Base - Length x Width
257A	51240	9" (225mm)	2-7/8 x 2-3/8" (72 x 60mm)
257B	51241	9" and 12" (225 and 300mm)	
257C	51242	12" (300mm)	3-1/2 x 3-3/16" (90 x 80mm)
257D	51243	12" and 18" (300 and 450mm)	

Spindles, Scribes and Standard Snugs for 57 and 257 Surface Gages			
Fits	Spindles	Scribers	Standard Snugs*
A and B Models	5/16 x 9" and 12" (8 x 225mm and 300mm)	9/64 x 6" (3.6 x 150mm)	PT18718 (EDP 50709) with 5/16" post hole†
C and D Models	3/8 x 12" and 18" (9.5 x 300mm and 450mm)	5/32 x 8-1/2" (4 x 216mm)	PT18724 (EDP 50710) with 3/8" (9.5mm) post hole

† For snug with 8mm post hole diameter, order PT27171, EDP 66457.

* Will hold scribes, rods or indicator stems ranging from 3/32-1/4" (2.4-6.35mm) and allows use with these test indicators: 196, 651, 711**, 564**, 708**, 811**, 650, 709**

** Snugs must be used with the proper indicator holder.



SURFACE GAGES

57S, 58S UNIVERSAL SNUGS FOR SURFACE GAGES, INDICATORS AND ACCESSORIES

- Convenient attachment of scribes and test indicator shanks to surface gage magnetic bases, indicator tool post holders and gage rods
- Fits all 57 and 257 Surface Gages and test indicator clamps and post holders
- Permits the use of all of our test indicators: 196, 564*, 650, 651, 708*, 709*, 711 and 811*. (*Snugs must be used with the proper indicator holder)

Universal Snugs for Surface Gages

Cat. No.	EDP	Spindle Hole Diameters		Gripping Hole Diameters	
		in	mm	in	mm
57S	50296	5/16, 3/8	8, 9.5	9/64, 5/32, 3/16, 1/4	3.5, 4, 4.8, 6.35
58S	56613	1/4, 5/16, 3/8	6.35, 8, 9.5	Range from 3/32-1/4	Range from 2.4-6.35

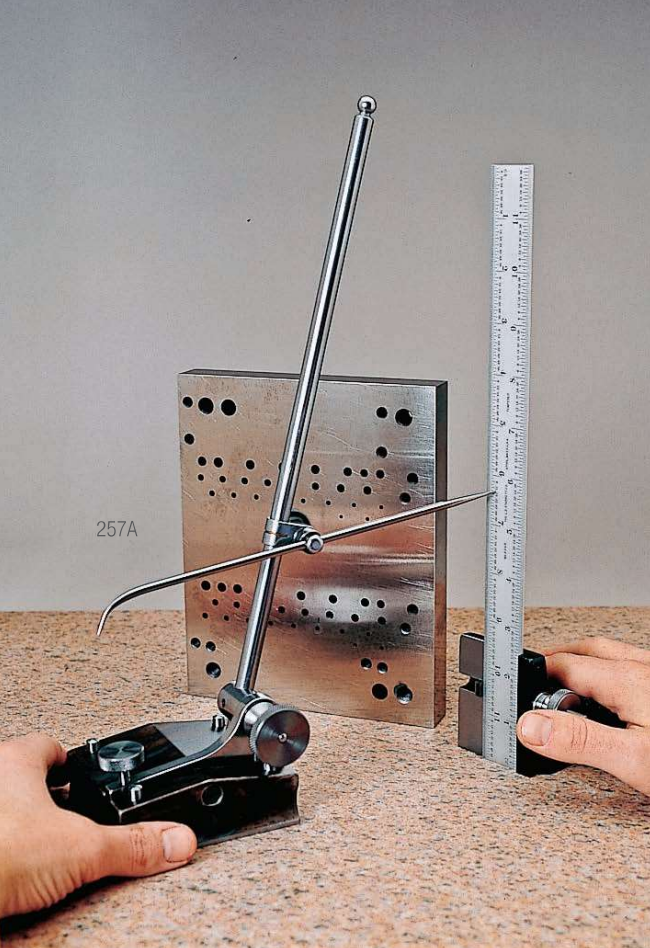

SURFACE GAGES

Surface Gages are designed for a wide variety of uses. This is a basic tool for machinists and toolmakers. The main uses are for accurately scribing lines, transferring measurements and for probing surfaces in inspection work.

Lines can be scribed to heights and depths. Lines can also be scribed on horizontal surfaces referenced from gage pins on the tool.

Scribers are usually set in relation to rule graduations (our 62 Rule Holder is valuable in this respect) or height gages.

Marrying one of these tools with one of our test indicators makes easy work of checking flatness, parallelism, height and depth.

