



## DIAL INDICATOR DIAMETER GAGES

These gages measure both outside and inside diameters by comparing dimensions to gage blocks or an adjustable setting master. Each gage consists of a strong rectangular box beam with a sensitive gaging contact at one end and a reference gaging contact at the other.

- All of the diameter gages have these features:
- The sensitive contact transfers dimensions to the dial indicator through a linear friction-free mechanism
- There are two gage feet at the reference end of the gage and one foot at the sensitive end of the gage to set the gage on the work and align the contacts
- Gage depth is set by adjusting the gage feet up or down
- A lever-actuated reverse mechanism loads the gage for either inside or outside diameter measurements
- The gage contacts are easily changed to I.D. or O.D. gaging by turning them end for end
- Unless otherwise specified, the dial indicator sent with the gage reads in .0005" increments with a total range of  $\pm .030$ ". The dial has a double row of graduations reading in opposite directions – minus in red and plus in black

On the following pages we list our standard line but to suit other needs we also can furnish the following:

1. Any length that is required
2. Any dial indicator with inch or millimeter reading
3. 717 Electronic Gage Amplifier and Gaging Head in place of the indicator
4. Electronic indicators can also be furnished on any of these gages except the 1102
5. Special contact shapes
6. Gaging contacts with more depth



## INDICATOR DIAMETER GAGES



## 1102, 1102M Dial Indicator Diameter Gages

## 1-12"/25-300MM

This is a light, easy-to-handle gage that is a workhorse in its range. Approximate weight is 1lb, 12oz. (0.8kg). The gaging depth can be set within a range of 0-1" (0-25mm) by adjusting the rest foot. Dial indicators are the 81-136-623 Inch Reading (.0005") or 81-181-623 Millimeter Reading (0.01mm) models.

The gage should be checked against our 1127 Master for a precise reference standard during production gaging (See the following pages). Also available on request with .0001" or 0.002mm graduations.

1102 and 1102M Dial Indicator Diameter Gages			
Cat. No.	EDP	Length Range	Height Adjustment
1102	56134	1-12" (.0005" Indicator)	0-1"
1102-1	69004	1-12" (.0001" Indicator)	0-1"
1102M	65020	25-300mm	0-25mm

Case for 1102 and 1102M Dial Indicator Diameter Gages		
Cat. No.	EDP	Description
1102ZZ	56136	Storage Case to Hold Both Gage and 1127 Master

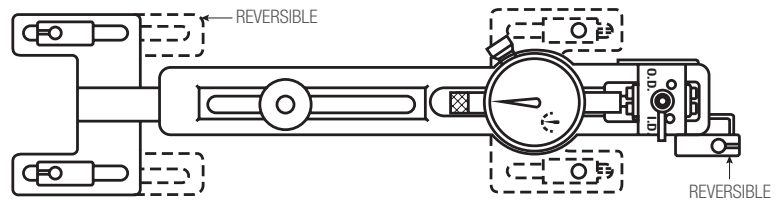

1102 and 1102M Dial Indicator Diameter Gages	
Photo Key	Description
A	Range Lock Screw
B	I.D.-O.D. Preload Reversing Mechanism Lever
C	Rest Foot
D	Reference Contact
E	Sensitive Contact

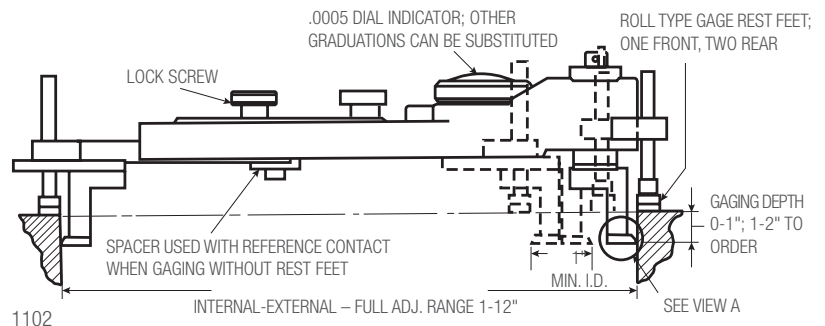

## STANDARD CONTACTS FURNISHED WITH GAGE

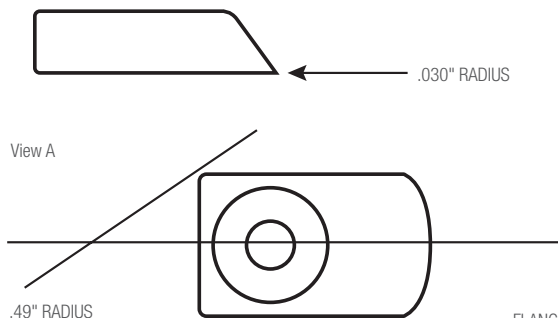

## SPECIAL CONTACTS DESIGNED TO ORDER

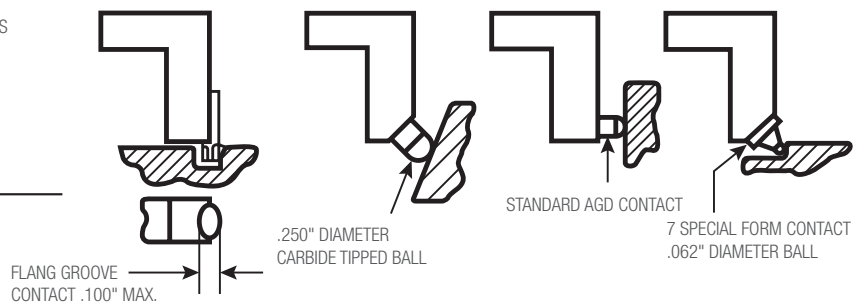

# INDICATOR DIAMETER GAGES

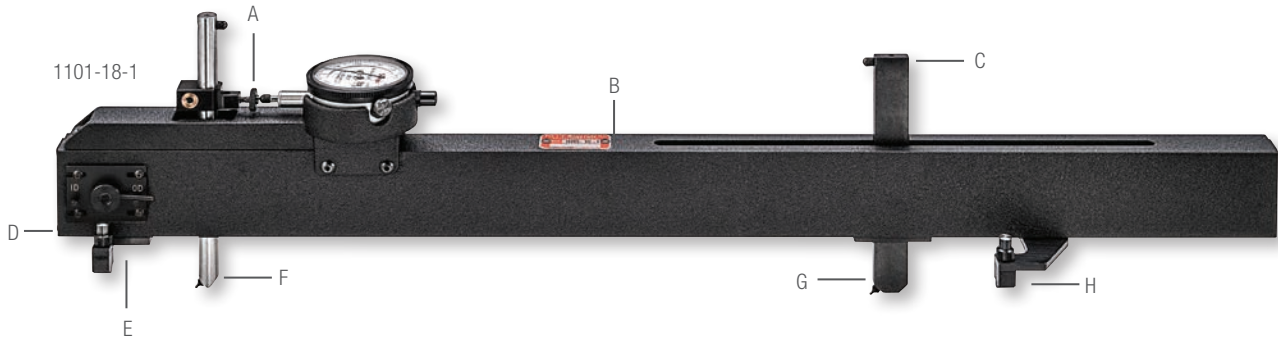

## 1101, 1101M DIAL INDICATOR DIAMETER GAGES

12-60"/300-1500MM

These gages allow for measurement beyond the size range of our 1102 models. Each gage adjusts a full 6" or 150mm. The contact carriers are vertically adjustable to handle various work depth. Special contacts are available.

This tool has dowel (line) contacts at one end of the gage feet, and a button (point) contact gage at the other end of the feet. These can be reversed as needed and the gaging depth can be set within a range of 2-3/4" or 70mm.

This gage should be checked against our 1126 Master for a precise reference standard during production gaging (See the following pages).

1101 and 1101M Dial Indicator Diameter Gages	
Photo Key	Description
A	Dial Indicator Fine-Adjusting Screw
B	Beam – Rectangular Box Section
C	Contact for Added Applications
D	I.D.-O.D. Preload Reversing Mechanism Lever
E	Combination Dowel/Button Rest Feet
F	Sensitive Contact
G	Reference Contact
H	Mounting Plate with Combination Dowel and Button Rest Feet

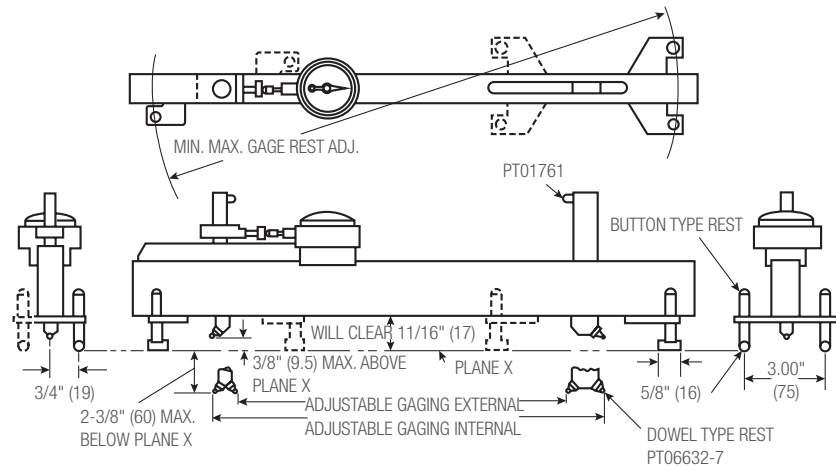

1101 and 1101M Dial Indicator Diameter Gages									
Length		Inch Reading - .0005" Graduations		Millimeter Reading - .01mm Graduations		Inch Reading - .0001" Graduations		Millimeter Reading - .002mm Graduations	
in	mm	Cat. No.	EDP	Cat. No.	EDP	Cat. No.	EDP	Cat. No.	EDP
12-18	300-450	1101-18	53144	1101M-450	65015	1101-18-1	69005	1101M-450-2	69021
18-24	450-600	1101-24	53146	1101M-600	65016	1101-24-1	69006	1101M-600-2	69022
24-30	600-750	1101-30	53148	1101M-750	65017	1101-30-1	69007	1101M-750-2	69023
30-36	750-900	1101-36	53150	1101M-900	65018	1101-36-1	69008	1101M-900-2	69024
36-42	900-1050	1101-42	53152	1101M-1050	65019	1101-42-1	69009	1101M-1050-2	69025
42-48	1050-1200	1101-48	53154	1101M-1200	65021	1101-48-1	69010	1101M-1200-2	69026
48-54	1200-1350	1101-54	53156	1101M-1350	65022	1101-54-1	69011	1101M-1350-2	69027
54-60	1350-1500	1101-60	53158	1101M-1500	65023	1101-60-1	69012	1101M-1500-2	69028
<b>Gaging Contact Range:</b>		±.050"		±1.3mm		±.050"		±1.3mm	

Sent without case unless otherwise ordered. To order case, specify the Catalog and "ZZ" (For example: 1101ZZ-18).



## INDICATOR DIAMETER GAGES



## 1100, 1100M Heavy-Duty Dial Indicator Diameter Gages

12-60"/300-1500MM

These gages combine heavy-duty construction features with adaptability for a wide range of internal and external measurements. The adjustable dowel rest legs ride on slotted mounting plates for horizontal adjustment. Each of the legs are vertically adjustable to obtain the proper rest position on the work and correct alignment on the gaging contacts. 2" or 50 mm range is the vertical adjustment.

The gaging contacts are radiused but may be modified by request to suit special gaging conditions.

The indicator and its housing can be rotated through to 360° so that the indicator may be read at the most convenient angle. The gage should be checked against our 1126 Master for a precise reference standard during production gaging (See the following pages).

## 1100 and 1100M Heavy-Duty Dial Indicator Diameter Gages

Photo Key	Description
A	I.D.-O.D. Preload Reversing Mechanism Lever
B	Tamper Proof Dial Indicator Fine-Adjust Screw
C	Beam – Rectangular Box Section
D, E	Adjustable Dowel Rest Leg
F, K	Dowel Rest
G	Sensitive Contact
H	Slotted Rest Leg Mounting Plate
I	Reference Contact
J	Reference Contact Carrier

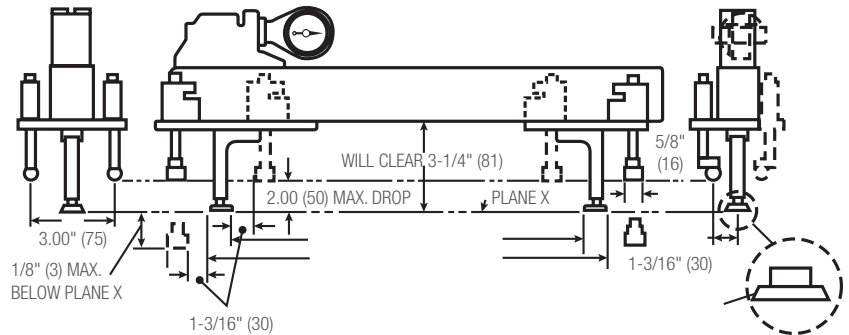

## 1101 and 1101M Dial Indicator Diameter Gages

Length in mm	Inch Reading - .0005" Graduations		Millimeter Reading - .01mm Graduations		Inch Reading - .0001" Graduations		Millimeter Reading - .002mm Graduations		
	Cat. No.	EDP	Cat. No.	EDP	Cat. No.	EDP	Cat. No.	EDP	
12-18 300-450	1101-18	53144	1101M-450	65015	1101-18-1	69005	1101M-450-2	69021	
18-24 450-600	1101-24	53146	1101M-600	65016	1101-24-1	69006	1101M-600-2	69022	
24-30 600-750	1101-30	53148	1101M-750	65017	1101-30-1	69007	1101M-750-2	69023	
30-36 750-900	1101-36	53150	1101M-900	65018	1101-36-1	69008	1101M-900-2	69024	
36-42 900-1050	1101-42	53152	1101M-1050	65019	1101-42-1	69009	1101M-1050-2	69025	
42-48 1050-1200	1101-48	53154	1101M-1200	65021	1101-48-1	69010	1101M-1200-2	69026	
48-54 1200-1350	1101-54	53156	1101M-1350	65022	1101-54-1	69011	1101M-1350-2	69027	
54-60 1350-1500	1101-60	53158	1101M-1500	65023	1101-60-1	69012	1101M-1500-2	69028	
<b>Gaging Contact Range:</b>		±.050"		±1.3mm		±.050"		±1.3mm	

Sent without case unless otherwise ordered. To order case, specify the Catalog and "ZZ" (For example: 1101ZZ-18).



# INDICATOR DIAMETER GAGES

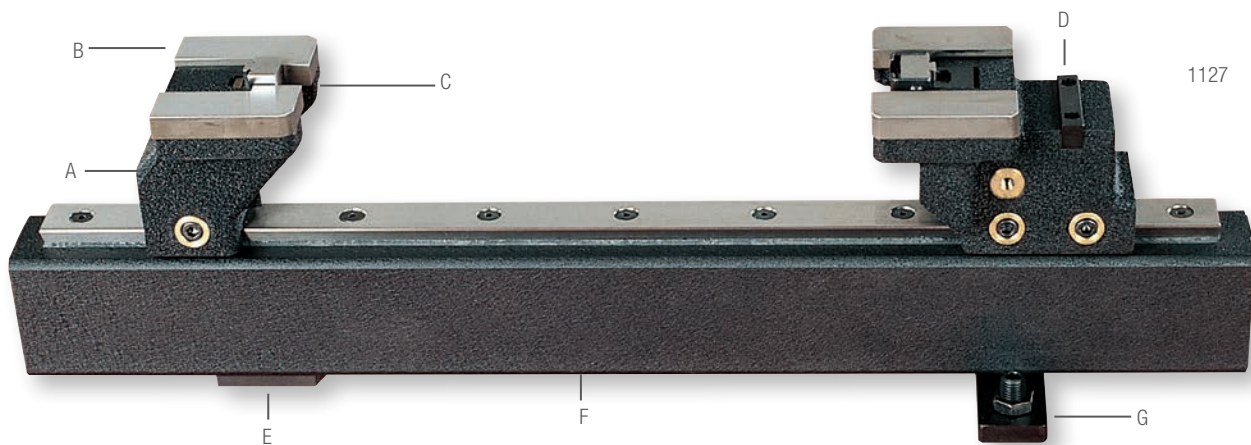

## 1127 INTERNAL-EXTERNAL ADJUSTABLE SETTING MASTER FOR STARRETT 1102 DIAMETER GAGES

EDP 56135

This set master is used with our 1102 Diameter Gages. The internal adjustment range is 1–12" (25-300mm) and external adjustment is 5-1/4–12" (133-300mm). Storage case is available to hold both the gage and master (Catalog 1102ZZ, EDP 56136).

### 1127 Internal-External Adjustable Setting Master for Starrett 1102 Diameter Gages

Photo Key	Description
A	Sensitive Head
B	Hardened Rest Platen
C	Anvil
D	Reference Head
E	Fixed Single Point Button Rest
F	Beam – Rectangular Box Section
G	Leveling Screws (2)

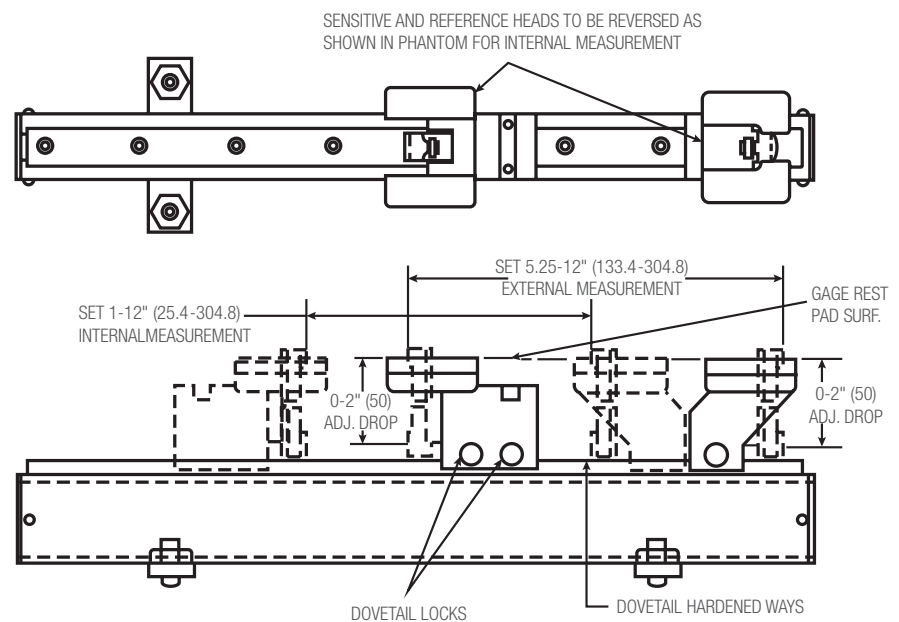

## SETTING MASTERS FOR DIAL INDICATOR DIAMETER GAGES

These setting masters are used to check and reset diameter gages under production gaging conditions. Each master consists of a rigid box beam with reference and sensitive heads which are individually adjustable along dovetail ways.

A platen on each head locates the diameter gage from its feet. The position of the gage contacts is matched by the anvils on the masters which are vertically adjustable. The reference head anvil has a fine adjustment for final settings, plus a restrictor to help position the gage in the master.

Both heads can be reversed for I.D. or O.D. settings. Each master has a fixed single point rest and two leveling screws which provide a three-point suspension. All contact and working surfaces are hardened and ground.

The setting procedure is as follows: set the diameter gage precisely to gage blocks or height gages. Then, using the diameter gage, set the master which can then be used as a precise reference standard for the diameter gage during production gaging.





## INDICATOR DIAMETER GAGES



### 1126 INTERNAL-EXTERNAL ADJUSTABLE SETTING MASTERS FOR STARRETT 1100 AND 1101 DIAMETER GAGES

12-60"/300-1500MM

These set masters are used to check and reset Starrett 1100 and 1101 Diameter Gages under production gaging conditions. The range is from 12-60" or 300-1500mm.

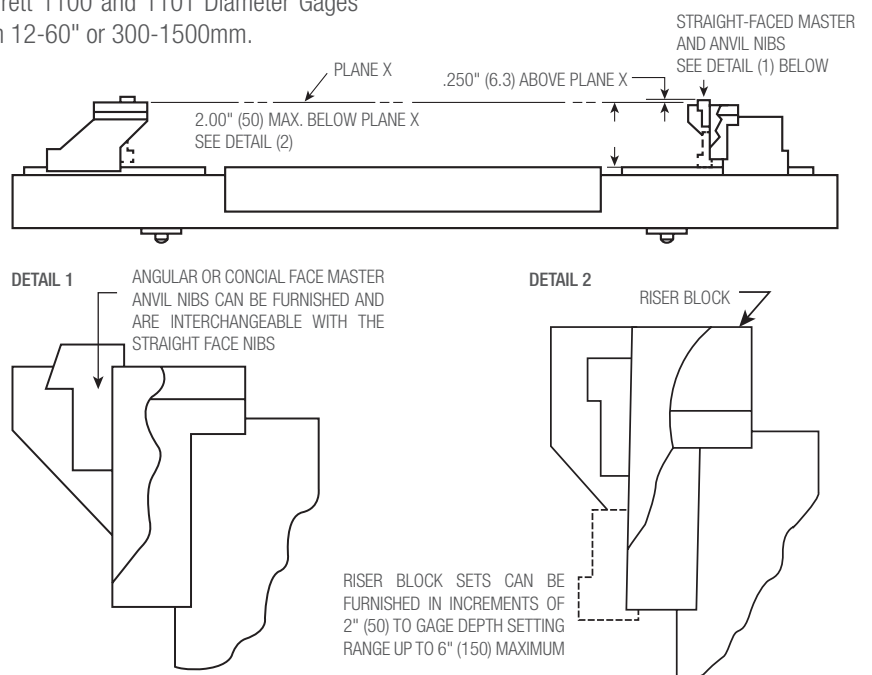

#### 1126 Internal-External Adjustable Setting Masters for Starrett 1100 and 1101 Diameter Gages

Photo Key	Description
A	Sensitive Head
B	Hardened Rest Platen
C	Anvil
D	Reference Head
E	Leveling Screws (2)
F	Beam – Rectangular Box Section
G	Fixed Single Point Button Rest

ANGULAR OR CONICAL NIBS AND RISER BLOCKS QUOTED UPON REQUEST

#### 1126 Internal-External Adjustable Setting Masters for Starrett 1100 and 1101 Diameter Gages

Cat. No.	EDP	Case Only Cat. No.	Length Range		For Use With Diameter Gage Nos.			
			in	mm	in	mm	in	mm
1126-18	53160	1126ZZ-18	12-18	300-450	1100-18	1100M-450	1101-18	1101M-450
1126-24	53161	1126ZZ-24	18-24	450-600	1100-24	1100M-600	1101-24	1101M-600
1126-30	53162	1126ZZ-30	24-30	600-750	1100-30	1100M-750	1101-30	1101M-750
1126-36	53163	1126ZZ-36	30-36	750-900	1100-36	1100M-900	1101-36	1101M-900
1126-42	53164	1126ZZ-42	36-42	900-1050	1100-42	1100M-1050	1101-42	1101M-1050
1126-48	53165	1126ZZ-48	42-48	1050-1200	1100-48	1100M-1200	1101-48	1101M-1200
1126-54	53166	1126ZZ-54	48-54	1200-1350	1100-54	1100M-1350	1101-54	1101M-1350
1126-60	53167	1126ZZ-60	54-60	1350-1500	1100-60	1100M-1500	1101-60	1101M-1500

Setting masters for larger diameters are also available by request – priced on the application.

In addition to the products detailed in this section, we have made many other special function gages to suit a wide variety of our customers' specific requirements.

If you have a special application, we invite you to submit your drawings and specifications to our Special Order Department at 121 Crescent Street, Athol, MA 01331, USA. We will be happy to provide a prompt quotation.

