



SBS-2510

Digital Density Meter

User Manual



1-800-554-2243
www.sbsbattery.com
Test@sbsbattery.com

Table of Contents

1	Introduction	2
2	Safety Information	2
2.1	Definitions of signal words and warning symbols	3
2.2	Product specific safety notes	3
3	Design and Function	5
3.1	Instrument overview	5
3.2	User interface	6
3.2.1	Home screen	6
3.2.2	Icons on the screen	6
4	Installation and commissioning	7
4.1	Scope of delivery	7
4.2	Unpack the SBS-2510.....	7
4.3	Charge the SBS-2510	8
4.3.1	Charge with the AC adapter	8
4.3.2	Charge with a computer.....	8
4.4	Setup for working with the sample pump	9
4.4.1	Activate the sample pump mode	9
4.4.2	Install the filling tube	9
5	Operation	10
5.1	Start up the SBS-2510	10
5.2	Shut down the SBS-2510	10
5.3	Navigate and enter information.....	10
5.3.1	Navigate through menus and confirm settings	10
5.3.2	Enter text and numbers	10
5.4	Typical phases of density determinations.....	11
5.4.1	Fill the measuring cell and measure the density.....	11
5.4.2	Prepare the measuring cell for the next sample.....	12
5.5	Example: Density determination using the sample pump	12
5.5.1	Configure the method	12
5.5.2	Perform the density determination	13
6	Transfer Results (printing, exporting, pairing with SBS-6500)	14
6.1	Saving and exporting data.....	14
6.1.1	USB stick data transfer option.....	14
6.1.2	Bluetooth export of results to SBS-6500 battery resistance tester.....	15
7	Maintenance	15
7.1	Maintenance schedule.....	15
7.2	Clean the SBS-2510	16
7.2.1	Clean the housing	16
7.2.2	Clean the measuring cell.....	16
7.2.2.1	Clean using the sample pump	16
7.3	Check the measurement accuracy	17
7.3.1	Example: Test with water	17
7.3.1.1	Configure the test	17
7.3.1.2	Perform the test.....	18
7.3.2	Measures if a test fails	19
7.4	Replace the battery	19
7.5	Replace the sample pump	19
7.6	Prepare the SBS-2510 for storage	20
7.7	Dispose of the SBS-2510	20

8	Technical data	21
8.1	SBS-2510	21
8.2	Measurement.....	22

1 Introduction

Thank you for choosing a SBS SBS-2510. The SBS-2510 is a handheld measuring instrument used to determine the density of liquids.

About this document

This document provides you with the information you need to get started with your SBS handheld SBS-2510.

The instructions in this document refer to SBS-2510 running firmware version V1.0.0 or higher.



A PDF version of this manual is available online.

<https://www.sbsbattery.com/sbs-2510-digital-battery-hydrometer.html>

If you have any additional questions, contact your authorized SBS sales representative or dealer.

Conventions and symbols

Note: For useful information about the product.



Refers to an external document.

Elements of instructions

■ Prerequisites

1 Step

2 ...

⇨ Intermediate results

⇨ Results

2 Safety Information

- The User Manual is printed and delivered with the instrument.
- Keep User Manual for future reference.

Only use the instrument according to the User Manual. If you do not use the instrument according to this document or if the instrument is modified, the safety of the instrument may be impaired and Mettler-Toledo GmbH assumes no liability.



User Manual is available online.

<https://www.sbsbattery.com/sbs-2510-digital-battery-hydrometer.html>

2.1 Definitions of signal words and warning symbols

Safety notes contain important information on safety issues. Ignoring the safety notes may lead to personal injury, damage to the instrument, malfunctions and false results. Safety notes are marked with the following signal words and warning symbols:

Signal words

WARNING A hazardous situation with medium risk, possibly resulting in death or severe injury if not avoided.

NOTICE A hazardous situation with low risk, resulting in damage to the instrument, other material damage, malfunctions and erroneous results, or loss of data.

Warning symbols



Electrical shock



General hazard: read the User Manual for information about the hazards and the resulting measures.

Caution: a hazardous situation with low risk, resulting in minor or moderate injury if not avoided.

2.2 Product specific safety notes

Intended use

The SBS-2510 is designed to be used by trained staff and is intended for measuring the density of liquid samples that are compatible with the materials with which they come into contact.

The SBS-2510 is designed for indoor and outdoor operation in dry conditions. The following site requirements apply:

- Ambient conditions within the limits specified in the technical data
- No corrosive gas atmosphere
- No explosive atmosphere
- No powerful electric or magnetic fields

Any other type of use and operation beyond the limits of use stated by Storage Battery Systems, LLC without consent is considered as not intended.

FCC Rules

This device complies with Industry Canada license-exempt RSS standard(s) and part 15 of the FCC Rules. Operation is subject to the following two conditions: (1) this device may not cause interference, and (2) this device must accept any interference, including interference that may cause undesired operation of the device. Changes or modifications not expressly approved by the party responsible for compliance could void the user's authority to operate the equipment.

This equipment has been tested and found to comply with the limits for a Class A digital device, pursuant to Part 15 of the FCC rules. These limits are designed to provide reasonable protection against harmful interference when the equipment is operated in a commercial environment. This equipment generates, uses, and can radiate radio frequency energy and, if not installed and used in accordance with the instruction manual, may cause harmful interference to radio communications. Operation of this equipment in a residential area is likely to cause harmful interference in which case the user will be required to correct the interference at his own expense.

Responsibilities of the instrument owner

The instrument owner is the person holding the legal title to the instrument and who uses the instrument or authorizes any person to use it, or the person who is deemed by law to be the operator of the instrument. The instrument owner is responsible for the safety of all users of the instrument and third parties.

Storage Battery Systems, LLC assumes that the instrument owner trains users to safely use the instrument in their workplace and deal with potential hazards. Storage Battery Systems, LLC assumes that the instrument owner provides the necessary protective gear.

Safety notes



WARNING

Danger of death or serious injury due to electric shock!

Contact with parts that carry a live current can lead to death or injury.

- 1 Only use the SBS AC adapter designed for your instrument.
- 2 Keep all electrical cables and connections away from liquids and moisture.
- 3 Check the cables and the plugs for damage and replace damaged cables and plugs.



CAUTION

Injury due to incorrect handling of the battery

The battery can explode or ignite and cause injury or damage the SBS-2510 if it is not handled correctly.

- 1 Do not store or use the battery at temperatures below -20 °C or above 60 °C.
- 2 Do not subject the battery to mechanical stresses like pressure, bending or impacts.



NOTICE

Damage to the measuring cell due to solidifying samples

Hot samples cool down during the measurement. If the samples solidify in the measuring cell, you can no longer empty the measuring cell.

- Only measure samples with a viscosity below 1000 mPa*s at ambient temperature.



NOTICE

Damage to the instrument due to the use of unsuitable parts

Using unsuitable parts with the instrument can damage the instrument or cause it to malfunction.

- Only use parts from SBS that are intended to be used with your instrument.

3 Design and Function

3.1 Instrument overview

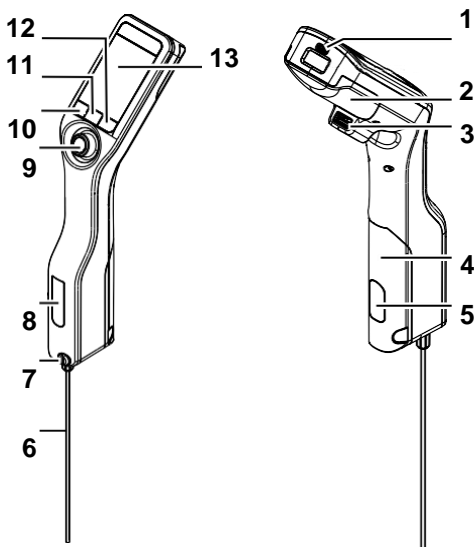

No.	Name	Function
1	USB-C socket	To connect the SBS-2510 with the AC adapter or a computer.
2	Battery cover	To access the battery.
3	USB-A socket	To connect a USB printer or Bluetooth dongle.
4	Sample pump cover	To access the sample pump.
5	Sample pump window	To view the sample pump and to check if the sample pump is filled or empty.
6	Filling tube	To fill and drain the measuring cell.
7	Filling opening with locking screw	To fill and drain the measuring cell using a syringe. The locking screw closes off the filling opening.
8	Measuring cell window	To view the measuring cell and to check if the measuring cell is filled or empty.
9	Navigation joystick	To navigate through the menus.
10	Key 1	To start up the SBS-2510, select menu items and to navigate.
11	Key 2	To select menu items and to navigate.
12	Key 3	To select menu items and to navigate.
13	Screen	To display settings and results.

3.2 User interface

3.2.1 Home screen









No.	Name	Explanation
1	Status ribbon	Displays the current date, time, battery charge status
2	Method ribbon	Displays the type of density determination and the method identification or the selected standard. <ul style="list-style-type: none"> • MS: measurement using a method • TE: test • ADJ: adjustment
3	Sample ID ribbon	Displays the sample ID.
4	Measuring ribbon	Displays the unit, the measured value or result and the temperature of the measuring cell.
5	Sampling ribbon	Displays the current status of the sample pump or syringe.
6	Key functions ribbon	Displays the function of the keys.

3.2.2 Icons on the screen

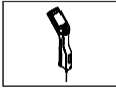
Icon	Location	Explanation
	Status ribbon	SBS-2510 is sending data to the printer.
	Status ribbon	Shows the charge of the battery.
	Status ribbon	Battery is charging.
	Sampling ribbon	Syringe mode activated. The sample pump is deactivated.
	Sampling ribbon	Sample pump activated and piston in the lowermost position.
	Sampling ribbon	Sample pump activated and piston in the uppermost position

4 Installation and commissioning

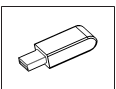
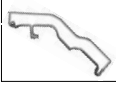
4.1 Scope of delivery

Part		Order number
	Handheld SBS-2510	SBS-2510
	Filling Tube 190 mm <ul style="list-style-type: none">• Tube• Connector syringe/filling tube• Washer	2510-TUBE-190
	Battery Li-Ion 2400mAh	2510-BATTERY
	Power Supply and Adapter	2510-PWRSUP
	USB-Charge Cable	2510-CABLE
	Bluetooth Dongle	2510-DONGLE
	Protective Cover	2510-COVER
	User Manual	-

4.2 Unpack the SBS-2510

- 1 Remove the SBS-2510 from the protective packaging.
- 2 Store the packing material for later transport over long distances.

- 3 Check if you received all parts listed in the scope of delivery.
- 4 Inspect the parts visually for flaws or damage.
- 5 If parts are missing or damaged, report it immediately and file a freight claim if needed.

4.3 Charge the SBS-2510

You can either charge the SBS-2510 using the supplied AC adapter or a computer. Recharging an empty battery takes approximately three hours.

4.3.1 Charge with the AC adapter

The AC adapter is suitable for all supply line voltages ranging from 100...240 V AC and 50/60 Hz.



⚠ WARNING

Danger of death or serious injury due to electric shock!

Contact with parts that carry a live current can lead to death or injury.

- 1 Only use the SBS-2510 AC adapter designed for your instrument.
- 2 Keep all electrical cables and connections away from liquids and moisture.
- 3 Check the cables and the plugs for damage and replace damaged cables and plugs.



NOTICE

Damage to the AC adapter due to overheating

If the AC adapter is covered or in a container, it is not sufficiently cooled and overheats.

- 1 Do not cover the AC adapter.
- 2 Do not put the AC adapter in a container.

Assemble the AC adapter

- 1 Slide the desired set of prongs (1) into the AC adapter (2).
- 2 Insert the USB-A plug of the USB-C cable in the USB-A socket of the AC adapter.

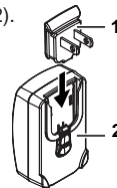

Connect the SBS-2510 to the power supply

- 1 Insert the USB-C plug of the USB-C cable in the USB-C socket of the SBS-2510.
 - 2 Install the cables in such a way that they cannot be damaged or interfere with operation.
 - 3 Insert the plug of the AC adapter in a power outlet that is easily accessible.
- ⇒ The SBS-2510 starts charging and the  icon is displayed.

Change the prongs of the AC adapter

- 1 Pull the plug of the AC adapter out of the power outlet.
- 2 Push the button (2) and slide the set of prongs (1) out.
- 3 Slide the desired set of prongs into the AC adapter.

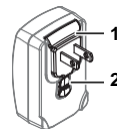

4.3.2 Charge with a computer

- A running computer with USB-A sockets (USB 2.0 or higher) is available.
- 1 Insert the USB-C plug of the USB-C cable in the USB-C socket of the SBS-2510.
 - 2 Install the cables in such a way that they cannot be damaged or interfere with operation.

- 3 Insert the USB-A plug in the USB-A socket of the computer.
⇒ The SBS-2510 starts charging and the  icon is displayed.

4.4 Setup for working with the sample pump

441 Activate the sample pump mode

- 1 Press the **Menu** key.
- 2 Navigate to **Settings > Measurement > Sampling**.
⇒ The **Sampling** window opens.
- 3 Navigate to **Sample pump**.
- 4 Press the **OK** key.
- 5 Navigate back to the home screen.
⇒ The icon  is displayed in the sampling ribbon.

442 Install the filling tube

- The filling tube (tube (1), connector (2) and washer (3)) is assembled.

- The locking screw (2) is installed and tight.
- Screw the connector (1) of the filling tube into the opening (3) and tighten it.

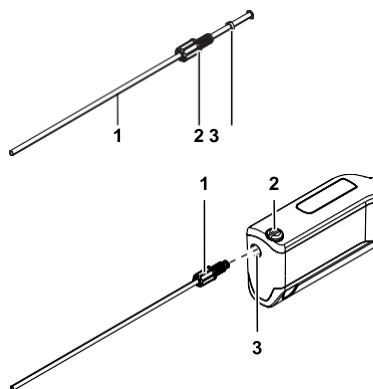

5 Operation

5.1 Start up the SBS-2510

- Press key 1 (1).
 - ⇒ A short beep is played.
 - ⇒ A welcome message is displayed.
- ⇒ The home screen opens. The SBS-2510 is ready to use.

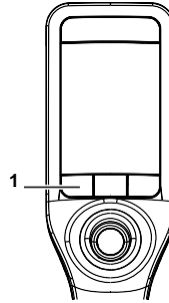

5.2 Shut down the SBS-2510

- Press and hold any of the keys or the navigation joystick for more than 3 s.
 - ⇒ A beep is played and the screen goes dark.
- ⇒ The control circuits for the keys and the navigation joystick are energized. The rest of the SBS-2510 is no longer energized.

5.3 Navigate and enter information

5.3.1 Navigate through menus and confirm settings

- 1 Press the **Menu** key.
- 2 To navigate to a desired menu, move the navigation joystick up or down.
- 3 To navigate to a submenu of the selected menu, move the navigation joystick to the right.
- 4 To go back, move the navigation joystick to the left.

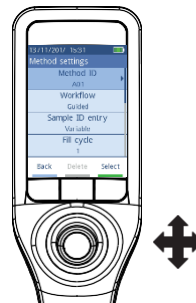

Confirm settings

In every menu, where the function of key 3 is marked with a green bar, you can press the navigation joystick to confirm the selection.

Shortcut to the method list

- The home screen is open.
- Move the navigation joystick to the left.
 - ⇒ The **Methods** window opens.

5.3.2 Enter text and numbers

- The keyboard window is open.
- 1 Navigate to the character, number, symbol or icon.
 - 2 Press the navigation joystick to confirm the selection of the character, number, symbol or icon.
 - 3 To confirm the entered information and leave the keyboard window, press the **OK** key.

Keyboard overview

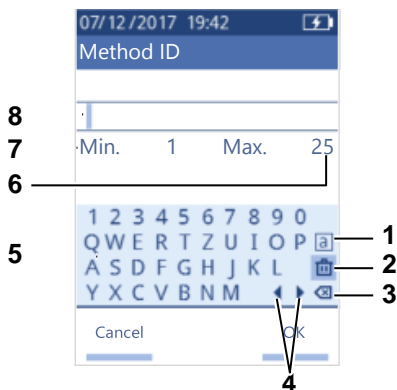

No.	Icon	Function
1		Cycles between the screens with small, capital or special characters.
2		Deletes all entered characters.
3		Deletes the character to the left of the cursor.
4		Moves the cursor.
5	–	Displays available characters, numbers and symbols.
6	–	Maximum number of characters you can enter.
7	–	Minimum number of characters you need to enter.
8	–	Displays the entered characters.

5.4 Typical phases of density determinations

Density determinations include the following two phases.

- Fill the measuring cell with sample and perform the measurement.
- Prepare the measuring cell for the next sample.

541 Fill the measuring cell and measure the density

Because the measuring cell always contains residue from the previous sample or the cleaning solution, it is important that you remove the residue using the new sample. This is only possible if the residue is soluble in the new sample.

To achieve good results, make sure that the measuring cell contains only the sample you want to measure and that there are no bubbles in the measuring cell.

You can use the sample pump or syringes to fill, drain and rinse the measuring cell. The sample pump is used for samples with a viscosity up to 100 mPa*s. Syringes are typically used if the viscosity of the samples is above 100 mPa*s.

See also

Example: Density determination using the sample pump } Page 13

5.42 Prepare the measuring cell for the next sample

At the end of this phase, the residue in the measuring cell must be soluble in the next sample. The solubility of the sample defines if you can drain the measuring cell or if you need to rinse it.

Drain

If the next sample dissolves the sample you just measured, you can drain the cell.

Rinse

If the next sample does not dissolve the sample you just measured, you have to rinse the measuring cell with a cleaning solution. The cleaning solution must dissolve the sample that you just measured and the next sample. When you rinse the measuring cell, the cleaning solution removes the residue from the original sample.

See also

Clean the measuring cell } Page 16

5.5 Example: Density determination using the sample pump

The following chapters show you how to configure and perform a density determination of deionized water at room temperature 77.0°F (25°C).

Summary of the configuration

- Guided density determination
- Filling and draining with the sample pump
- Evaluation if result lies within specified limits

5.5.1 Configure the method

- The density unit is set to [g/cm³].
 - **Confirmation of results** in **Settings** is activated.
 - The home screen is open.
- 1 Move the navigation joystick to the left.
⇒ The **Methods** window opens.
 - 2 Press the **New** key.
⇒ The **Method settings** window opens.
 - 3 Navigate to **Method ID** and enter a name with up to 25 characters.
 - 4 Press the **OK** key.
⇒ The method is listed in the **Methods** window.
 - 5 Change the parameter settings to the values shown in the following table.

Parameter	Setting	Explanation
Workflow	Guided	The SBS-2510 prompts users to fill and drain the measuring cell.
Sample ID entry	Variable	The SBS-2510 prompts users to enter the sample ID before the density is measured.
Fill cycle	3	The SBS-2510 prompts users to fill and drain the measuring cell twice and then fill the measuring cell for the measurement.

Parameter	Setting	Explanation
Fill speed	High	The pump fills the measuring cell with 80 % of the maximum pump speed.
Measurement reliability	Medium	The result is saved as soon as the measured temperature value stays within 0.72 °F(0.4 °C) for 10 s.
Calculation > Category	Density	A density is calculated.
Calculation > Calculation	d	The density is not compensated to a certain temperature.
Calculation > Result limits	Yes	The SBS-2510 evaluates if the result is within a defined range.
Lower limit	0.9972 g/cm ³	Defines the lower limit of the range.
Upper limit	0.9977 g/cm ³	Defines the upper limit of the range.
Clean	Drain	Users are prompted to drain the measuring cell.
Printout	None	The result is not printed.

552 Perform the density determination

Start the method

- The SBS-2510 is set up to work with the sample pump.
 - The piston is in the lowermost position.
 - The home screen is open.
- 1 Move the navigation joystick to the left.
 - 2 Navigate to the method you want to use and press the **Start** key.
 - ⇒ The home screen opens.
 - 3 Press the **Start** key.
 - ⇒ The **Sample ID** window opens.
 - 4 Enter the identification.
 - 5 Press the **OK** key.

Rinse the measuring cell

- 1 Immerse the filling tube into the sample (1).
- 2 Press the **OK** key.
 - ⇒ The sample pump starts and stops when the piston is in the uppermost position.
- 3 Hold the filling tube over the waste beaker (2).
- 4 Press the **OK** key.
 - ⇒ The sample pump starts and stops when the piston is in the lowermost position.
- 5 Clean the end of the filling tube with a clean tissue.
- 6 Repeat the steps once.

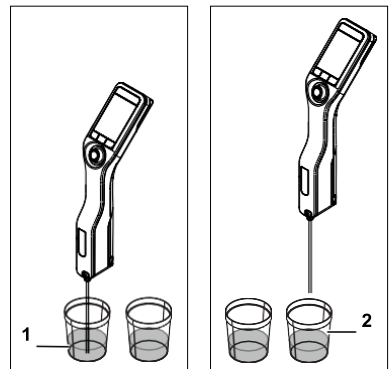

Fill the measuring cell and measure the density

- 1 Immerse the filling tube into the sample (1).
- 2 Press the **OK** key.
 - ⇒ The sample pump starts and stops when the piston is in the uppermost position.
- 3 Make sure there are no bubbles in the measuring cell.
 - ⇒ The measurement starts.
 - ⇒ When the background of the measuring ribbon changes color, the measurement is finished.
 - ⇒ The measured value is saved in the results.
- 4 Press the **OK** key.

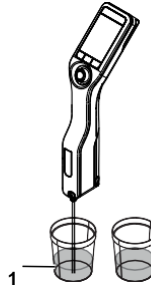

Drain the measuring cell

- 1 Hold the filling tube over the waste beaker (1).
- 2 Press the **OK** key.
 - ⇒ The sample pump starts and stops when the piston is in the lowermost position.
- 3 Clean the end of the filling tube with a clean tissue.

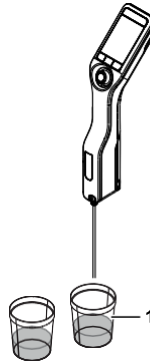

6 Transfer results (printing, exporting, pairing with SBS-6500)

6.1 Saving and exporting data

Measured results are stored in the memory of the SBS-2510 Digital Density Meter. These results will remain stored in memory even after transfer has been completed and must be manually deleted on the unit to clear the internal memory.

This section will describe the two default methods of saving the data to an Excel worksheet or direct Bluetooth import into the SBS-6500 Battery Resistance Tester.

Other methods of retrieving, printing and exporting data are possible.

6.1.1 USB stick data transfer option

- 1 Insert a compatible USB drive into the USB socket of the SBS-2510 Digital Density Meter.
(*USB drive must be formatted in the FAT32 file format*)
- 2 Press the **Results** button on the main screen of the unit.
- 3 Press the **Report** button on the Results screen of the unit.
- 4 Under report options, Select **USB Stick** using the Navigation Joystick so print option is selected to USB Stick and press the **OK** button.

5 Press the **Start** button. You will see a message appear **Connecting to the USB Flash Drive** and receive an audible beep when the transfer of data is completed.

Note: *This method exports all data stored in the memory of the SBS-2510 into a single file that can be accessed via Microsoft Excel.*

6.1.2 Bluetooth export of results to SBS-6500 battery resistance tester

- 1 Insert the supplied Bluetooth dongle into the USB port of the SBS-2510.
- 2 Press the **Results** button on the main screen of the unit.
- 3 Press the **Report** button on the Results screen of the unit.
- 4 Under report options, Select **SBS-6500** using the Navigation Joystick so print option is selected to SBS-6500 and press the **OK** button.
- 5 Press the **Start** button. You will see a message appear **Connecting to Bluetooth Dongle** and receive an audible beep when the connection is established.
- 6 You will see a message **Initializing Bluetooth Dongle** appear and then the screen will advance to **Waiting for SBS-6500**
- 7 Press the **SG Upload** button of the SBS-6500 unit and follow the procedure for importing specific gravity readings and saving them in the correct battery string location. (Guidance on the operation of the SBS-6500 unit is in its own operating manual.) Below is a link for the full SBS-6500 Battery Analyzer Manual)

<https://www.sbsbattery.com/media/PDFs/SBS-6500-Battery-Analyzer-Manual.pdf>

Note: *All readings stored in the memory are transferred at the same time.*

7 Maintenance

In this chapter you find descriptions of the maintenance tasks you should perform on your SBS-2510. Any other maintenance tasks need to be performed by a service technician that has been qualified by Storage Battery Systems, LLC.

If you experience problems with your SBS-2510, contact your authorized Storage Battery Systems, LLC Sales or service representative.

SBS recommends that a preventive maintenance and calibration certification is done at least once a year through your authorized SBS sales or service representative.

<https://www.sbsbattery.com/sbs-2510-digital-battery-hydrometer.html>

7.1 Maintenance schedule

If the standard operating procedures of your company require other maintenance intervals, use the intervals listed in the standard operating procedures.

Frequency	Task	See
Daily	Clean the measuring cell at the end of the work day.	[Clean the measuring cell } Page 16]
	Perform a test with deionized water.	[Check the measurement accuracy } Page 17]

7.2 Clean the SBS-2510



NOTICE

Danger of damage to the SBS-2510 due to inappropriate cleaning methods

In-appropriate cleaning agents can damage the housing or other parts of the SBS-2510. If liquids enter the housing they can damage the SBS-2510 and void the warranty.

- 1 Make sure the cleaning agent is compatible with the material of the part you want to clean.
- 2 Make sure that no liquid enters the interior of the SBS-2510.

If you have questions about the compatibility of cleaning agents, contact your authorized SBS sales representative or dealer.

<https://www.sbsbattery.com/sbs-2510-digital-battery-hydrometer.html>

721 Clean the housing

SBS recommends the following cleaning agents:

- Water
- Water with a mild detergent

Procedure

- The SBS-2510 is shut down.
- Wipe the housing with a cloth moistened with the cleaning agent.

722 Clean the measuring cell

Because the measuring cell always contains residue from the last sample, there is a risk that the measuring cell can be damaged by the sample. To prevent such damages, SBS recommends that you clean the measuring cell at the end of each sample series.

To clean the measuring cell, you need to rinse the measuring cell with a cleaning solution. The cleaning solution must have the following properties.

- Does not chemically interact with the material of the measuring cell.
- Dissolves the sample that was just measured.
- Evaporates without leaving incrustations.

SBS recommends the following cleaning agents:

Sample	Cleaning solution
Water Water based	Deionized water
Acids, concentrated	Water (flush the measuring cell with plenty of water to remove the heat from the reaction of water and acid)
Alkaline, concentrated	0.3...0.5 % deconex solution
Samples with fats or oily components	0.3...0.5 % deconex solution
Petrochemical samples Edible oils and fats	Toluene, xylene or petrol ether mixtures

7.2.2.1 Clean using the sample pump

- The SBS-2510 is set up to work with the sample pump.
 - The cleaning solution is defined and available.
 - The piston is in the lowermost position.
- 1 Immerse the filling tube in the cleaning solution (1).

- 2 Move the navigation joystick upwards and let go.
⇒ The sample pump starts and stops when the piston is in the uppermost position.
- 3 Lift the filling tube out of the cleaning solution and hold it over the waste beaker (2).
- 4 Move the navigation joystick downwards and let go.
⇒ The sample pump starts and stops when the piston is in the lowermost position.
- 5 Clean the end of the filling tube with a clean tissue.
- 6 Repeat the steps until all residue from the sample is removed.
- 7 Move the navigation joystick upwards and let go.
⇒ The sample pump fills the measuring cell with air.
- 8 Move the navigation joystick downwards and let go.
⇒ Most of the cleaning solution is removed from the measuring cell.
- 9 Clean the end of the filling tube with a clean tissue.

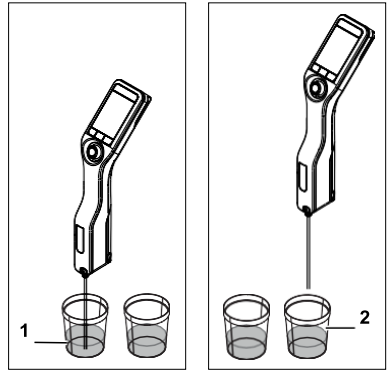

7.3 Check the measurement accuracy

To check the measurement accuracy of the SBS-2510, you need to configure and perform a test

7.3.1 Example: Test with water

The following chapters show you how to configure and perform a guided test with deionized water at room temperature 77.0°F (25 °C).

7.3.1.1 Configure the test

- The density unit is set to [g/cm³].
 - **Confirmation of results** in **Settings** is activated.
- 1 Press the **Menu** key.
 - 2 Navigate to **Test**.
⇒ The **Test** window opens.
 - 3 Change the parameter settings to the values shown in the following table.

Parameter	Setting	Explanation
Workflow	Guided	The SBS-2510 prompts users to fill and drain the measuring cell.
Standard type	Water	The SBS-2510 uses predefined values for the water measurement.
Standard ID entry	Variable	The SBS-2510 prompts users to enter the identification before the density is measured.
Fill cycle	3	The SBS-2510 prompts users to fill and drain the measuring cell twice and then fill the measuring cell for the measurement.
Fill speed	High	The pump fills the measuring cell with 80 % of the maximum pump speed.

Parameter	Setting	Explanation
Tolerance d	0.0002 g/cm ³	The result is marked as passed if it falls within the following range. d nominal ± Tolerance d
Clean	Drain	Users are prompted to drain the measuring cell.
Printout	None	The result is not printed.

7.3.1.2 Perform the test

Start the test

- The SBS-2510 is set up to work with the sample pump.
 - The measuring cell has been cleaned.
 - The piston is in the lowermost position.
- 1 Press the **Menu** key.
 - 2 Navigate to **Test**.
 - ⇒ The **Test** window opens.
 - 3 Press the **Start** key.
 - ⇒ The home screen opens.
 - 4 Press the **Start** key.
 - ⇒ The **Standard ID** window opens.
 - 5 Enter the identification.
 - 6 Press the **OK** key.

Rinse the measuring cell

- 1 Immerse the filling tube in the water.
- 2 Press the **OK** key.
 - ⇒ The sample pump starts and stops when the piston is in the uppermost position.
- 3 Hold the filling tube over the waste beaker.
- 4 Press the **OK** key.
 - ⇒ The sample pump starts and stops when the piston is in the lowermost position.
- 5 Clean the end of the filling tube with a clean tissue.
- 6 Repeat the steps once.

Fill the measuring cell and measure the density

- 1 Immerse the filling tube in the water.
- 2 Press the **OK** key.
 - ⇒ The sample pump starts and stops when the piston is in the uppermost position.
- 3 Make sure there are no bubbles in the measuring cell.
 - ⇒ The measurement starts.
 - ⇒ When the background of the measuring ribbon changes color, the measurement is finished.
 - ⇒ The measured value is saved in the results.
- 4 Press the **OK** key.

Drain the measuring cell

- 1 Hold the filling tube over the waste beaker.
- 2 Press the **OK** key.
 - ⇒ The sample pump starts and stops when the piston is in the lowermost position.
- 3 Clean the end of the filling tube with a clean tissue.

7.3.2 Measures if a test fails

- 1 Check if the correct standard has been used, and if needed repeat the test with the correct standard.
- 2 If the test continues to fail, clean the measuring cell with a cleaning solution that dissolves your samples and dissolves in the standard.
- 3 Repeat the test.
- 4 If the test continues to fail, repeat the test twice and compare all three results.
- 5 If the results are not the same, clean the measuring cell and perform tests until the test passes or the results of three consecutive tests are the same.
- 6 If the test continues to fail and the results of three consecutive tests are the same, restore the factory adjustment data and repeat the test.
- 7 If the test continues to fail, perform an adjustment.

See also

- Clean the measuring cell } Page 16

7.4 Replace the battery

The SBS-2510 works with a rechargeable 2400 mAh Li-Ion battery that you can order from Storage Battery Systems, LLC.

- 1 Press on the lower part (1) of the battery cover and push the battery cover up.
- 2 Pull the upper part of the battery out of the battery compartment and lift the battery out.

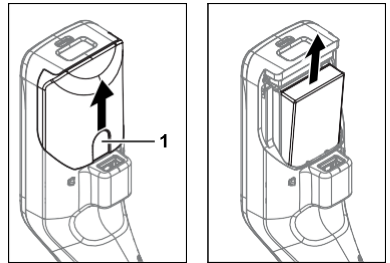

- 3 Insert the lower part of the battery at an angle into the battery compartment.
- 4 Push the upper part of the battery into the battery compartment.
- 5 Slide the battery cover from above onto the SBS-2510.

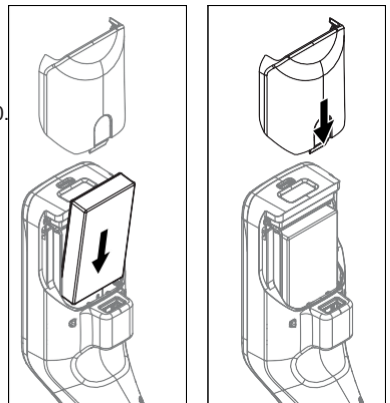

See also

- Technical data } Page 21

7.5 Replace the sample pump

Remove the sample pump

- The measuring cell is drained.
- 1 Move the navigation joystick upwards and let go.
 - ⇒ The sample pump starts and stops when the piston is in the uppermost position.

- 2 Shut down the SBS-2510.
- 3 Press on the grip recesses (4) of the cover and lift the lower part of the cover out of the housing.
- 4 Pull the top of the cover out of the housing.
- 5 Lift the piston (1) out of the guide system.
- 6 Pull the cylinder (2) up and out of its guide system (3).

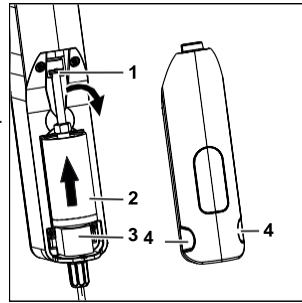

Install the sample pump

- 1 Insert the cylinder (3) of the sample pump in its guide system (2).
- 2 Insert the piston (1) in its guide system (2).
- 3 To check if the sample pump works, move the navigation joystick downwards and let go.
 - ⇒ The sample pump starts and stops when the piston is in the lowermost position.
- 4 Reinstall the cover of the sample pump.

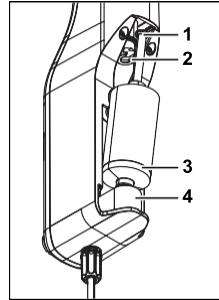

7.6 Prepare the SBS-2510 for storage

The SBS-2510 can be stored at temperatures of $-4...+122\text{ }^{\circ}\text{F}$ ($-20...+50\text{ }^{\circ}\text{C}$). But the lifespan of the battery is reduced when it is stored at high temperatures.

- 1 Clean the measuring cell.
- 2 Shut down the SBS-2510.
- 3 Clean the housing.
- 4 Store the SBS-2510 in a dry and clean place.

See also

- 📖 Clean the SBS-2510 } Page 16
- 📖 Technical data } Page 21

7.7 Dispose of the SBS-2510

In conformance with the European Directive 2012/19/EU on Waste Electrical and Electronic Equipment (WEEE) this device may not be disposed of in domestic waste. This also applies to countries outside the EU, per their specific requirements.

Please dispose of this product in accordance with local regulations at the collecting point specified for electrical and electronic equipment. If you have any questions, please contact the responsible authority or the distributor from which you purchased this device. Should this device be passed on to other parties, the content of this regulation must also be related.



8 Technical data

8.1 SBS-2510

Characteristic	Value	
Power rating instrument	Input values	5 V DC, 1.0 A
	Connector type	USB C
Power rating AC adapter	Input values	100...240 V AC, 0.3 A
	Input frequency	50 - 60 Hz
	Output values	5 V DC, 1.0 A
Battery	Type	Rechargeable lithium-ion
	battery Capacity	2400 mAh
	Temperature range for charging	32...104 °F (0...40°C)
Dimensions	Width	2.20 Inches (56 mm)
	Length	11.33 Inches (288 mm)
	Depth	3.15 Inches (80 mm)
	Weight	0.78 Pounds (355 g)
Materials	Housing	PBT (polybutylene terephthalate)
	Measuring cell	Borosilicate glass
	Parts in contact when working with sample pump	PTFE (polytetrafluorethylene) PVDF (polyvinylidene difluoride) EPDM (ethylene propylene diene monomer (M- class) rubber) FFKM (perfluoro-elastomers) Borosilicate glass
	Filling tube	PTFE (polytetrafluorethylene)
	Connector for filling tube or syringe	PP (polypropylene)

Ambient Conditions

Characteristic	Value
Ambient temperature	14...122°F (-10...+50°C)
Relative humidity	Max. 80% (non-condensing) at 88°F (31°C), linear fall to 50% at 104°F (40°C)
Altitude	Up to 6560 Feet (2000 m) above sea level
Pressure	Atmospheric pressure
Use	In interior spaces
Overvoltage category	II
Pollution degree	2
IP code	IP5X

Storage temperatures

Characteristic	Value
Instrument	-4...122°F (-20°C...+50°C)

Characteristic	Value	
Battery	Storage for up to 1 month	-4°F...140°F (-20°C...+60°C)
	Storage for up to 3 months	-4°F...113°F (-20°C...+45°C)
	Storage for up to 1 year	-4°F...86°F (-20°C...+30°C)

Directives, standards and REACH regulation

Directives and standards complied with are listed on the declaration of conformity. SVHC candidate substances according to REACH (Article 33)

Material	CAS No.
1,3-Propanesultone	1120-71-4
PZT (Lead Zirconate Titanate)	12626-81-2

8.2 Measurement

Characterist	Value	
Density	Measuring range	0.000...3.000 g/cm ³
	Accuracy ¹⁾	± 0.001 g/cm ³
	Repeatability	± 0.0005 g/cm ³
	Resolution	0.0001 g/cm ³
Temperature	Range for sample	32...122°F (0...50°C)
	Resolution	0.1°F (0.1°C)
	Accuracy	±0.3°F (±0.2°C)

¹⁾ For viscosity range of 0...200 mPa*s

Measurement scales

Characteristic	Value	
Ethanol (d) % w/w	Range	0.0...100.0% w/w
	Accuracy	±1.0% w/w
Ethanol (d) % v/v	Range	0.0...100.0% v/v
	Accuracy	±1.0% v/v
Proof (IP)	Range	0.0...175.0 Proof
	Accuracy	±1.75 Proof
Proof (US)	Range	0.0...200.0 Proof
	Accuracy	±2.0 Proof
Light Baumé	Range	10...100 °Bé
	Accuracy	±0.4 °Bé
Heavy Baumé	Range	0...72 °Bé
	Accuracy	±0.1 °Bé
H ₂ SO ₄ % w/w	Temperature range	50...122°F (10...50°C)
	Concentration range	0.0...100.0% w/w
	Accuracy	±1.0% w/w
H ₂ SO ₄ % v/v	Temperature range	50...122°F (10...50°C)
	Concentration range	0.0...100.0% v/v
	Accuracy	±1.0% v/v

Characteristic		Value
Brix (d) % w/w	Range	0.0...85.0% w/w
	Accuracy	±0.3% w/w
Plato	Range	0.0...85.0 °P
	Accuracy	±0.3 °P



Storage Battery Systems LLC
N56 W16665 Ridgewood Drive
Menomonee Falls, WI 53051

www.sbsbattery.com

800-554-2243

sbs@sbsbattery.com

Manufacturer Information:

Mettler-Toledo GmbH

Im Langacher 44
8606 Greifensee, Switzerland
www.mt.com/contact
Subject to technical changes.
© Mettler-Toledo GmbH 01/2020
30564492A

SBS-2510 Users Manual, Rev. 04-20-IOM2510

April 2020