

**USER MANUAL**

# ***SurgeX XR315***

**SurgeX<sup>®</sup> Surge Eliminator  
For  
Residential Applications**

**Software Version 1.0/1.1**

<b><u>1</u></b>	<b><u>DESCRIPTION.....</u></b>	<b><u>3</u></b>
<b><u>2</u></b>	<b><u>FEATURES .....</u></b>	<b><u>4</u></b>
<b><u>3</u></b>	<b><u>INSTALLATION.....</u></b>	<b><u>4</u></b>
<b>3.1</b>	<b>120 VOLT CONNECTIONS .....</b>	<b>5</b>
<b>3.2</b>	<b>REMOTE CONTROL CONNECTIONS .....</b>	<b>5</b>
3.2.1	UP/DOWN CONTROL INPUTS .....	5
3.2.2	OVER-RIDE INPUT .....	6
3.2.3	EXTERNAL LED CONNECTIONS .....	6
3.2.4	CONFIRMATION CONNECTION.....	7
<b><u>4</u></b>	<b><u>QUICK START.....</u></b>	<b><u>8</u></b>
<b><u>5</u></b>	<b><u>PROGRAMMING .....</u></b>	<b><u>9</u></b>
<b>5.1</b>	<b>POWER CONTROL .....</b>	<b>9</b>
<b>5.2</b>	<b>OVER-RIDE CONTROL.....</b>	<b>9</b>
<b>5.3</b>	<b>12V DC OUTPUT .....</b>	<b>10</b>
<b>5.4</b>	<b>AUXILIARY RELAY .....</b>	<b>11</b>
<b>5.5</b>	<b>FRONT PANEL PUSH BUTTON .....</b>	<b>11</b>
<b>5.6</b>	<b>OUT-OF-RANGE AC VOLTAGE SHUT DOWN .....</b>	<b>12</b>
<b>5.7</b>	<b>RESTORE FUNCTIONS.....</b>	<b>12</b>
<b><u>6</u></b>	<b><u>APPLICATIONS .....</u></b>	<b><u>12</u></b>
<b>6.1</b>	<b>GENERAL POINTS .....</b>	<b>12</b>
6.1.1	CONTROLLING THE XR315 .....	13
6.1.2	12V DC OUTPUT .....	13
6.1.3	AUXILIARY RELAY.....	13
6.1.4	OVER-RIDE FUNCTION .....	14
6.1.5	OTHER FUNCTIONS.....	14
<b>6.2</b>	<b>SINGLE UNIT SYSTEM.....</b>	<b>15</b>
<b>6.3</b>	<b>EXPANDED SYSTEM .....</b>	<b>15</b>
<b>6.4</b>	<b>GANGED SYSTEM.....</b>	<b>15</b>
<b>6.5</b>	<b>CASCADED SYSTEM .....</b>	<b>16</b>
<b><u>7</u></b>	<b><u>TROUBLESHOOTING .....</u></b>	<b><u>23</u></b>
<b><u>8</u></b>	<b><u>ERROR CODES .....</u></b>	<b><u>24</u></b>
<b><u>9</u></b>	<b><u>SPECIFICATIONS.....</u></b>	<b><u>25</u></b>

## **1 Description**

The SurgeX<sup>®</sup> XR315 is a 120V, 15 Amp AC power quality product incorporating SurgeX<sup>®</sup> Advanced Series Mode<sup>®</sup> power conditioning and surge protection. The surge protection is rated A-1-1, the highest standard of the Federal Commercial Item Description for Endurance. The one rack-space steel enclosure is designed to be installed in a 19 inch equipment rack, or placed on a flat surface. A total of eight 120V receptacles are provided on the rear panel.

SurgeX ICE<sup>®</sup> Inrush Current Elimination circuitry is incorporated into the XR315. This eliminates problems associated with inrush currents from large loads such as amplifiers. With SurgeX ICE<sup>®</sup> it is not necessary to take inrush currents into account when designing the AC power for a system, and special time-delay circuit breakers are not required: you only need to ensure that the steady-state currents of all products plugged into the XR315 are within the 15 Amp rating.

The front panel houses a two-line back-lit LCD display which provides status information in normal use and allows interaction with menu items during programming. The character display intensity is adjusted by either a rotary dimmer knob or a push-button On/Off switch. Also on the front panel are two screwdriver-accessible rotary encoders which are used to step through and select from a menu of items which determine the operation of the unit. The power button, when pressed, causes the unit to power up or power down. This button can be disabled if not required. The LED incorporated into the button indicates the status of the unit. When the LED is off the unit is fully powered down; when it is on the unit is fully powered up; when it is flashing the unit is in the process of powering up or down.

A built-in AC voltmeter indicates the line voltage on the LCD display. The internal voltmeter is a peak reading type which was chosen because most electronic equipment incorporates a power supply that charges mostly during the AC peaks. Monitoring the peak of the AC provides a more useful indication of the real voltage available to the electronic equipment plugged into the XR315.

A built-in AC ammeter indicates the total current consumption of connected equipment on the LCD display. The internal ammeter is also a peak reading type.

A calculation of the total power being delivered to connected equipment is displayed on the second line of the LCD display. Power is calculated as the product of the line voltage and total current draw, and is displayed with the unit Watts "W". Volt-Amps ("VA") is the more correct unit of power, since the voltage and current measurements are based on a peak reading, but Watts is displayed for simplicity.

The XR315 is microprocessor controlled and designed to be versatile and expandable. Two or more XR315s can be connected together to provide control and power conditioning for larger systems. The XR315 can also control other SurgeX products with its auxiliary relay contacts and/or its 12V dc output. All options are set via the front panel and all connections are made at the rear panel. All set-up information is stored in non-volatile memory.

A plug-in Phoenix terminal block on the rear panel accommodates the remote control connections and also the low-voltage outputs. There are three inputs which control power state; one programmable 12V dc output; and one programmable auxiliary relay providing normally-open contacts. The inputs can be controlled by an applied DC voltage from 5V to 30V, by a contact closure, or by different types of switch; the input selection being made during programming. The inputs and 12V output are designed to withstand incorrect connections including polarity reversal and shorts.

## **2 Features**

- Unsurpassed SurgeX<sup>®</sup> Advanced Series Mode<sup>®</sup> surge elimination
- SurgeX<sup>®</sup> Impedance Tolerant<sup>®</sup> EMI/RFI filtering
- SurgeX<sup>®</sup> ICE<sup>®</sup> Inrush Current Elimination
- All functions easily programmed from the front panel
- Accepts both DC voltage and contact closure control inputs
- Two or more units can be ganged or cascaded together for larger systems
- Programmable auxiliary relay output can be used to control other SurgeX<sup>®</sup> products
- Programmable 12 Volt dc output can be used to control other SurgeX<sup>®</sup> products or drive LEDs
- Auxiliary relay or 12 Volt dc output can be programmed to provide confirmation feedback
- Built-in AC Voltmeter
- Built-in AC Ammeter
- Built-in Power Calculation
- Separate over-ride input can be used to force unit off or force unit on
- Adjustable under-voltage and over-voltage shut-down
- Optional restore after power failure feature

## **3 Installation**

The SurgeX XR315 is designed to rest on a flat surface or to be installed in a 19 inch equipment rack and requires one unit (1-U) of rack space. To place the XR315 on a flat surface, use four 6-32 Phillips pan head screws (included) to attach the four decorative feet (included). To install in an equipment rack, use eleven 6-32 Phillips flat head screws (included) to attach the removable rack-mounting brackets (included) to the sides of the product. Use the four thumbscrews provided with the product to secure the rack ears to the rack rails. These screws can be tightened by hand and do not require tools. Connect power to the unit by plugging the cord into a 120V ac, 15 amp wall or floor receptacle. Do not plug the unit into a relocatable power

tap. **\*CAUTION: Do not install this device if there is not at least 10 meters (30 feet) or more between the electrical outlet and the electrical service panel.**

### 3.1 120 Volt Connections

The XR315 has a total of 8 receptacles. Each receptacle is rated for a maximum load of 15 amps but the total load of the XR315 must not exceed 15 amps.

### 3.2 Remote Control Connections

Remote connections are wired to the green 7-pin plug-in Phoenix terminal block on the rear of the unit next to the power cord. The terminal block itself is provided in the accessory bag that you will find in the shipping box. After you have made the connections to the terminal block, plug it into the connector on the rear of the unit. Never solder (tin) wires before inserting in a terminal block – solder creeps and you will eventually have loose connections!

The connections are shown below:

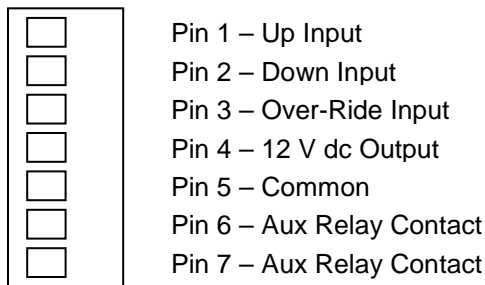

#### 3.2.1 Up/Down Control Inputs

The XR315 can be controlled by a DC voltage in the range 5V to 30V, by a contact closure (such as a relay), or by a switch. In this manual the terms “momentary” and “latching” are used when describing switches. A momentary switch is considered to be a switch which provides a connection only while it is actually held pressed, and a latching switch is considered to be a switch which remains in either the on or the off state (like a light switch). Momentary switches are preferred for use with the XR315 since multiple control locations can be used, and also because some of the functions of the XR315 are not available when a latching switch is used (see programming section). Switches with gold contacts are recommended for the best long-term reliability. The type of input is selected totally through programming, making the electrical connections straightforward. The six control options are discussed below:

- a) DC Voltage: The XR315 will power up when the voltage is present and power down when there is no voltage. Connect the positive wire to the “up” input, and the ground (or negative) wire to “common”. Program the input for “5-30 V dc”.

- b) Contact Closure: The XR315 will power up when the contacts are closed and power down when the contacts are open. Connect the two wires from the contacts to “up” and “common”. Program the input for “Latching”
- c) Momentary Switch(es): The XR315 will power up when a switch is pressed once and power down when a switch is pressed a second time. Connect the two wires from the switch(es) to “up” and “common”. Program the input for “Momentary”.
- d) Separate Up & Down Switches: The XR315 will power up when the UP switch is pressed and power down when the DOWN switch is pressed. Connect the two wires from the UP switch to “up” and “common”, and the two wires from the DOWN switch to “down” and “common”. Program the input for “Separate Up & Down”.
- e) Center-Off Switch: The XR315 will power up when the switch is pressed to the UP position and power down when the switch is pressed to the DOWN position. Connect the wire from the UP terminal to “up”, the wire from the DOWN terminal to “down”, and the wire from the COMMON terminal to “common”. Program the input for “Separate Up & Down”.
- f) Latching Switch: The XR315 will power up when the switch is closed and power down when the switch is open. Connect the two wires from the switch to “up” and “common”. Program the input for “Latching”.

Note: The front panel button will not operate with options a, b or f

### **3.2.2 Over-Ride Input**

The XR315 has the option of adding an over-ride function for purposes such as providing fire safety over-ride to force the system either on or off. An over-ride is initiated by applying a dc voltage of 5-30V or by a sustained contact closure. The selection of dc voltage or contact closure is accomplished during programming. This topic is covered fully in the programming section.

Connect the over-ride signal to the “over-ride” input and “common”. In the case of a dc voltage, connect the positive wire to “over-ride” and the negative wire to “common”.

### **3.2.3 External LED Connections**

The XR315 is able to drive external LEDs or other signaling devices through its 12V dc output which can provide up to 40mA of current. External LEDs connected in this way will mimic the red LED on the front panel. When connecting LEDs to the 12V output, a series resistor is required. For example, many LEDs work well with 10mA of current, so a 1K resistor is usually a good choice. If more than one LED is required, then use a separate series resistor for each LED. In this example, four external LEDs could be powered at 10mA each from one XR315. If more than four LEDs are required, it will be necessary to increase the series resistor so that the total load is not more than 40mA.

Connect each LED anode to “12V dc output” through a resistor, and the cathodes to “common”.

Program the 12V dc Output for “LED”. This causes LEDs connected to the XR315 to flash while the unit is powering up or powering down in the same manner as the front panel LED.

### 3.2.4 Confirmation Connection

The XR315 offers two ways to provide confirmation feedback to a central controller: a 12V dc output and isolated relay contacts. Confirmation tells the controller that the XR315 has indeed powered up or that it is fully powered down. If the 12V dc output and the aux relay contacts are not used for any other function, you will be free to choose whichever provides the best interface for the application. However, if one of these outputs is used for another function you will have to use the one that is available.

To use the 12V dc output for confirmation, connect “12V dc output” to the positive input of the controller and “common” to ground. The output will be at 12V when the XR315 is powered up and will be zero when the XR315 is powered down. Program 12V dc Output for “Confirm”. Note that the XR315 common terminal is shared between the inputs and the 12V dc output. If you need relay contacts for confirmation and you are using the aux relay for another function you can connect a small relay between the 12V dc output and common. The relay coil current must not be more than 40mA, and you must connect a diode such as a 1N4148 or 1N4002 across the relay coil (cathode to +12V dc) to suppress the back-EMF from the coil. If you need assistance with this please contact our technical support department.

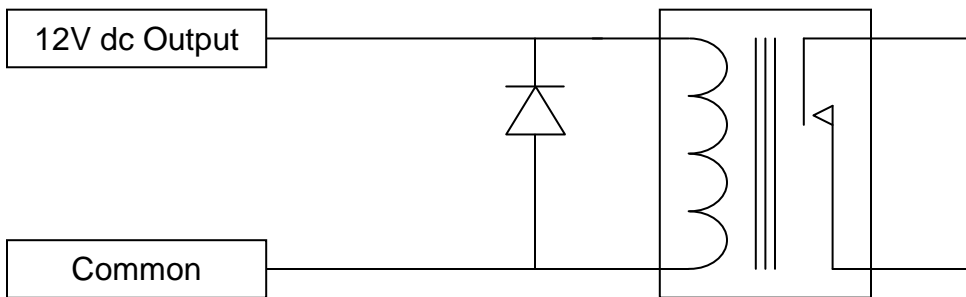

Connecting a 12 volt relay to the 12V dc output

To use the auxiliary relay contacts for confirmation, connect the contacts to the input of the controller. The relay contacts will be closed when the XR315 is powered up and open when the XR315 is powered down. The default for menu item “Aux Output” is “Confirm” so you do not need to program this item unless you previously changed it. The contacts are rated for 30V dc at 1 amp.

## 4 Quick Start

This section is intended to allow users with a simple straightforward system incorporating a single XR315 to get up and running with the minimum of effort. If this is not the case then skip this section and go directly to the section on detailed programming (section 5). If you are going to follow the quick start instructions, you only need to perform the following steps since the unit has been shipped with default settings suitable for basic operation.

1. Make all connections as per section 3.
2. Insert the screwdriver provided in the accessory kit in the hole labeled Select and turn it one click clockwise. Press the power button and you will see the first menu item “Unused” on the display. This is a function that is not available in the current software/hardware configuration.
3. Advance Select one click to get the second menu item “Up & Down Inputs”. Select the option required for the install by referring to section 3.2.1 and set the option by rotating Adjust.
4. If you have connected an LED to the 12V dc output for remote signaling, step through the menu until you reach “12V dc Output”. Then advance Adjust to select “LED”. This selection will make the remote LED mimic the LED on the front panel which flashes while the unit is powering up or powering down.
5. Turn Select fully counter-clockwise and press the power button to exit programming. Place two of the black plugs from the accessory kit into the adjustment holes to deter tampering and the unit is ready for use.

Although the above steps are all that are required to get the XR315 running, you may want to take a look at the following programming options to see if you want to make use of any of these functions. You will find these listed on the reverse side of the Programming and Connection Guide, and they are near the end of the menu that you step through by turning Select.

<b>Low Voltage Shutdown</b>	Shuts unit off if AC voltage drops below the set point
<b>High Voltage Shutdown</b>	Shuts unit off if AC voltage rises above the set point
<b>Power Fail Restore</b>	Turns unit back on after a power failure if unit was powered up when the power failed



## 5 Programming

The XR315 is a very versatile product and has 16 menu items that control its operation. Some menu items allow predetermined options to be selected and others allow time delays or voltage limits to be adjusted. All adjustments are made via the front panel and are achieved by turning the two screwdriver-accessible rotary encoders labeled Select and Adjust. Turning Select steps through the menu (shown on the first line of the display), and turning Adjust allows each menu item to be changed (shown on the second line of the display). The accessory kit contains a screwdriver suitable for making adjustments.

To enter the programming mode, first turn Select one click clockwise. The display will then tell you to press the power button. This puts you into the programming mode. All the options, delay times and voltage adjustments are set using this mode. When you have completed the set-up turn Select counter-clockwise until the display tells you to press the power button again. Doing so saves the new set-up information in non-volatile memory and puts you back into normal operation.

The instructions and notes that follow are in the same order as the actual menu items.

### *5.1 Power Control*

The following menu item must be set before the XR315 can be used in a system. This determines the type of control input: DC voltage, contact closure or switch. Please see section 3.2.1 for details.

#### **Up & Down Inputs**

Select the option as per section 3.2.1

### *5.2 Over-Ride Control*

The XR315 has an optional over-ride and there are four menu items that control this function. If you do not require an over-ride, you can skip the next four menu items since units are shipped with this function disabled. The over-ride can be used for such purposes as fire safety over-ride, and can be set to either force the unit on or force it off when an over-ride signal occurs. The over-ride input is also used for feedback when two or more XR315s are cascaded together. This is covered in the applications section.

- Over-Ride Input** Select “Contact Closure” if a relay or switch is used, or “5-30V dc” if a DC voltage is used.
- Over-Ride Func** This selects the functioning of the over-ride. Select “Disable” if you do not need an over-ride. If you want the over-ride to force the unit on select “Force On”, and if you want the over-ride to force the unit off select “Force Off”. If you are cascading two or more XR315s together then select “Master” for the first unit in the chain, and “Pass-Thru” for all other units in the chain except the last one.
- Over-Ride Option** This option allows a special delay to be selected for use only when there is an over-ride. This can be useful, for example, to power-up equipment faster than normal if there is an emergency and a PA is required. If the special delay is required select “Special Delay”, or if not, select “Use Main Delays”.
- Over-Ride Delay** This is the special delay (in seconds) for use only during an over-ride. The previous menu item must have been set to enable this delay.

### 5.3 12V dc Output

The programmable 12V dc output provides a nominal 12 volts at up to 40mA of direct current and is available at the rear of the unit. The 12V dc output can be used to provide confirmation to a central controller, to control another power distribution product, to drive LEDs, or to provide feedback to the previous XR315 in a cascaded chain. Please see the applications section for full details on setting up an expanded system. There are three menu items to control the 12V dc output: one to select the mode of operation and two to set the delay times. The two delay times are only applicable when option A, B, or C is selected for 12V dc Output. There is additional information on the 12V dc output in sections 3.2.3 and 3.2.4. If the DC output is not used it can be left at any setting.

- 12V dc Output** Select “Confirm” if you are using the DC output for confirmation or to drive a relay. Options “A”, “B” or “C” synchronize the operation of the relay to the same internal trigger as the receptacles on the rear panel of the XR315. Choose A, B, or C when the output is used to control an “RT” type SurgeX. Select “LED” if you are driving LEDs. (This causes the unit to flash the LEDs during power-up and power-down.) Select “Cascade” only when setting up two or more XR315s in cascade. All these options are covered in detail in the applications section.
- 12V Delay On** Set the delay time in seconds for the 12V dc output activation. This delay time begins with the same internal trigger as the receptacles on the rear panel of the XR315.
- 12V Delay Off** Set the delay time in seconds for the 12V dc output deactivation. This delay time begins with the same internal trigger as the receptacles on the rear panel of the XR315.

## 5.4 Auxiliary Relay

The programmable auxiliary relay provides a single normally-open contact which is available at the rear of the unit. The aux relay can be used to provide confirmation to a central controller, to control another power distribution product, or for controlling another XR315 when two or more are ganged or cascaded together. Please see the applications section for full details on setting up an expanded system. There are three menu items to control the aux relay: one to select the mode of operation and two delay times. The two delay times are only applicable when option A, B, or C is selected for Aux Output. There is additional information on the aux relay in section 3.2.4.

<b>Aux Output</b>	When using the aux relay for confirmation select “Confirm”. Options “A”, “B” or “C” synchronize the operation of the relay to the same internal trigger as the receptacles on the rear panel of the XR315. Choose A, B, or C when the relay is used to control an “RT” type SurgeX. “Gang” or “Cascade” is selected when two or more XR315s are ganged or cascaded together. All these options are covered in detail in the applications section.
<b>Aux Delay On</b>	Set the delay time in seconds for the auxiliary relay closing. This delay time begins with the same internal trigger as the receptacles on the rear panel of the XR315.
<b>Aux Delay Off</b>	Set the delay time in seconds for the auxiliary relay opening. This delay time begins with the same internal trigger as the receptacles on the rear panel of the XR315.

## 5.5 Front Panel Push Button

The front panel push button allows the unit to be powered up or powered down from the front panel. There is one menu item associated with the push button which allows it to be disabled or to operate only after a one second delay. The delay option prevents the unit inadvertently powering on or off if the push button is accidentally bumped. Note that the push button cannot be used in conjunction with applied voltage or latching type remote control inputs.

<b>Fr. Panel Button</b>	Select “Enable” for normal operation, “Delay” to operate only after a one-second delay, and “Disable” to prevent operation from the front panel.
-------------------------	--

## 5.6 *Out-of-Range AC Voltage Shut Down*

The XR315 has built-in line voltage monitoring and out-of-range shut down. The default limits are 90V at the low end and 150V at the high end, and shut down begins if the line voltage remains outside the set limits for 1 second or more. These limits are adjusted by using two menu items, with the low limit adjustable from 90V to 110V and the high limit adjustable from 130V to 150V. If the unit has shut down due to an out-of-range line voltage and the line voltage subsequently returns to normal, power up will only resume if the Power Fail Restore option (section 5.8) has been set to “Enable”.

**Low-V Shut Down** Set the low voltage shut down limit from 90V to 110V

**High-V Shut Down** Set the high voltage shut down limit from 130V to 150V

## 5.7 *Restore Functions*

There are two menu items which, when enabled, allow the XR315 to restore the original “on” condition after shut-down caused either by loss of AC power (or out-of-range AC) or by an over-ride. When these options are disabled, the XR315 will not power up when the condition that caused the shut down goes away. The restore functions cannot be used in conjunction with applied voltage or latching type remote control inputs.

**Pwr Fail Restore** Select “Enable” if you want the XR315 to power up after a power failure or out-of-range AC condition and the XR315 was powered up when this condition occurred. Select “Disable” if you don’t want this function. Factory Defaults: v1.0: Disabled, v1.1: Enabled.

**Override Restore** Select “Enable” if you want the XR315 to power up again after being forced off by an over-ride. Select “Disable” if you don’t want this function.

## 6 Applications

The XR315 can be used in four types of configuration: a single unit providing eight outlets; an expanded system where the XR315 controls remote turn-on SurgeX products; a ganged system where two or more XR315s are connected together such that they all turn on and off at the same time; a cascaded system where two or more XR315s are connected together such that the units turn on sequentially from one XR315 to the next XR315. Each configuration is covered separately in its own section, but first there are some general points which apply to all types of installation.

### 6.1 *General Points*

Section 3.2 provides detailed information about the remote control connections. If you have not already done so, please read section 3.2 before continuing. The information in section 6.1 applies to all types of installations and you should also read this section before continuing further.

### **6.1.1 Controlling the XR315**

The XR315 is primarily designed to be used with momentary action switches. A momentary switch is a switch where the contacts are closed only while the switch is actually pressed, such as a push switch. Using momentary switches allows several switches to be connected in parallel so that the XR315 can be controlled from multiple locations. A single push switch would cause the unit to power-up on the first press and then power down on the second press. A dual momentary switch, such as a center-biased rocker, or two separate push switches (one for UP and the other for DOWN), can also be used with equal versatility. It is up to the installer to choose the configuration. Whatever type of switch is used, switches with gold contacts are recommended for the best long-term reliability.

Where there are multiple control locations it is advantageous to use the 12V dc output to drive LEDs so that there is an LED at each control location. Up to four LEDs running at 10mA each can be powered from the 12V dc output. Each control location then has an indication of the operational status of the XR315 regardless of which location last initiated power-up or power-down.

The XR315 also supports latching switches, contact closure and applied DC voltage, but these types of input cannot be used with multiple control locations – they are intended primarily for a small system or for hook-up to a central controller. The front-panel push-button will not work with a latching switch, contact closure or applied voltage inputs.

### **6.1.2 12V DC Output**

The 12V dc output can be used to drive LEDs, thereby showing the operational status at remote control locations. This output can drive up to 40mA which can power four LEDs at 10mA each, or more LEDs at reduced current. A resistor is required for each LED to limit the current. The 12V dc output can also provide confirmation to a central controller or be used to drive a small relay (40mA maximum coil current). The 12V dc output can be configured to control an external bank of equipment as an alternative to or in additional to the aux relay. See section 3.2 for connection details and section 5.3 for programming details.

The 12V dc output has a special use when XR315s are cascaded together – this is covered in the section on cascaded systems.

### **6.1.3 Auxiliary Relay**

The primary uses of the aux relay are to control other remote turn-on products or to provide status feedback to a central controller to confirm that the unit has completed the requested operation. Details of using the aux relay to control other products are covered in the specific applications sections. The aux relay provides one normally-open contact at the rear terminal block and can handle 1 amp at up to 30 volts dc. See section 3.2 for connection details and section 5.4 for programming details.

The aux relay has a special use when XR315s are ganged or cascaded together – this is covered in the sections on ganged and cascaded systems.

#### **6.1.4 Over-Ride Function**

The XR315 has an over-ride function that can be used for fire safety and other applications where the power must be held on or forced off. The over-ride function is programmable so that it can be set to either force the unit off or force it on. When a signal is applied to the over-ride input the unit will be forced on or off regardless of the main inputs.

If the unit has been forced off by an over-ride, the Over-Ride Restore menu option determines whether the unit will power up again or remain off.

There is a special delay which can be used only with an over-ride condition. This allows a faster turn-on (or turn-off). It is not recommended to use the special delay with expanded systems.

The over-ride input can be programmed to accept either a contact closure or applied dc voltage. See section 3.2 for connection details and section 5.2 for programming details.

The over-ride input has a special use when XR315s are cascaded together. This is covered in the section on cascaded systems. If an over-ride is required with a ganged system use the over-ride input on the first XR315. If an over-ride is required with a cascaded system use the over-ride input on the last XR315.

#### **6.1.5 Other Functions**

Reading through the programming section is a good way to understand all the functions and options available in the XR315. Most of the functions are associated with main operation outlined in this section above. However, there are some other independent functions that can be selected:

The front panel button can be programmed to be operational, non-operational or operate after a one-second delay. Choosing the last setting prevents accidental power-up or power-down. See section 5.5 for more details.

The XR315 has built-in voltage limits that will cause the unit to power down if the line voltage is outside these limits. The low limit can be set from 90V to 110V and the high limit can be set from 130V to 150V. See section 5.6 for more details.

There are two “Restore” options. The first option allows the unit to restore to a power-on state after loss of AC power or out-of-range AC voltage. The second option allows the unit to restore to a power-on state after being forced off by an over-ride. See section 5.8 for more details.

## **6.2 Single Unit System**

Most of the information necessary to install and set up a single unit system can be found in sections 3.2 and 6.1. Figure 1 shows a single unit system controlled by momentary switches at three different locations, and figure 2 shows a single unit controlled by a central controller.

## **6.3 Expanded System**

A basic expanded system consists of a XR315 in combination with a remote turn-on SurgeX such as the SX1120-RT or the SX20-NE/RT. The auxiliary relay inside the XR315 is normally used to control the second unit although the 12V dc output can also be used for this purpose. The only difference in these remote control configurations is that, when the aux relay is used to control a second unit, it cannot be used for confirmation feedback to a central controller, and when the 12V dc output is used for control it cannot be used to drive LEDs.

If more current capability is required then additional SurgeX RT products can be connected to the second unit. Connect pins 6 & 7 of the second unit to pins 1 & 2 of the third unit, and so on.

It is possible to configure an expanded system by using both the aux relay and the 12V dc output to simultaneously control two separate pieces of equipment or two racks of equipment. In this case, refer to both figures 3 & 4 and follow the instructions below.

The XR315 in an expanded system can be controlled by the same inputs as a single unit system. Figure 3 shows how the two units are wired together using the aux relay contacts. The aux relay contacts on the XR315 (terminals 6 & 7) are connected to the contact closure inputs at the back of the RT (terminals 1 & 2). The aux relay must be programmed accordingly. The Aux Output menu item must be set to A, B or C. This synchronizes the aux relay to the internal trigger used to turn on the receptacles on the rear panel of the XR315. The Aux Delay On and Aux Delay Off delay times are then set to the desired turn-on and turn-off delays.

If an over-ride is used with an expanded system do not use the Special Delay.

Figure 4 shows how to configure an expanded system using the 12V dc output instead of the aux relay to control external units. This option allows the aux relay to be used for confirmation but it is then no longer possible to drive external LEDs from the 12V dc output. The programming and delay timing set up follow the same concepts as for the aux relay which is explained above.

## **6.4 Ganged System**

A ganged system consists of two or more XR315s connected together in such a way that they all turn off and on together. Figure 5 shows how to connect and program each unit in a three-unit system. If only two units are to be ganged together then ignore the middle unit in the diagram. If more than three units are to be ganged together then keep the first and last units set up as shown, add units in the middle and set them up and connect them in the same way as the middle unit in the diagram.

The remote control inputs should be connected to the first unit, and the same control options are available as for a single-unit system. If confirmation feedback is required for a central controller, use the aux relay contacts on the last unit.

If the low and high voltage shutdown points are narrowed from their defaults of 90V and 150V this should be done on the first unit only. The other units should be left set to 90V and 150V. The two restore options should only be enabled (if required) on the first unit.

If an over-ride is required connect it to the first unit.

## ***6.5 Cascaded System***

A cascaded system consists of two or more XR315s connected together such that they turn on and off one after another. Connecting a cascaded system together is a little more complicated than the other types of system because there must be feedback from each unit to the previous unit as well as control from each unit to the next unit. The 12V dc output (terminal 4) is used as the feedback source and the over-ride input (terminal 3) is used as the feedback input. Figure 6 shows how to connect and program each unit in a three-unit system. Note that terminals 5 and 6 are connected together for all units except the last one. If only two units are to be cascaded together then ignore the middle unit in the diagram. If more than three units are to be cascaded together then keep the first and last units set up as shown, add units in the middle and set them up and connected them in the same way as the middle unit in the diagram.

The remote control inputs should be connected to the first unit, and the same control options are available as for a single-unit system. If confirmation feedback is required for a central controller, use the aux relay contacts on the last unit.

If the low and high voltage shutdown points are narrowed from their defaults of 90V and 150V this should be done on the first unit only. The other units should be left set to 90V and 150V. The two restore options should only be enabled (if required) on the first unit.

If an over-ride is required connect it to the last unit and program that unit to accept the type of over-ride you need.



**Single-Unit System Controlled by Momentary Switches**

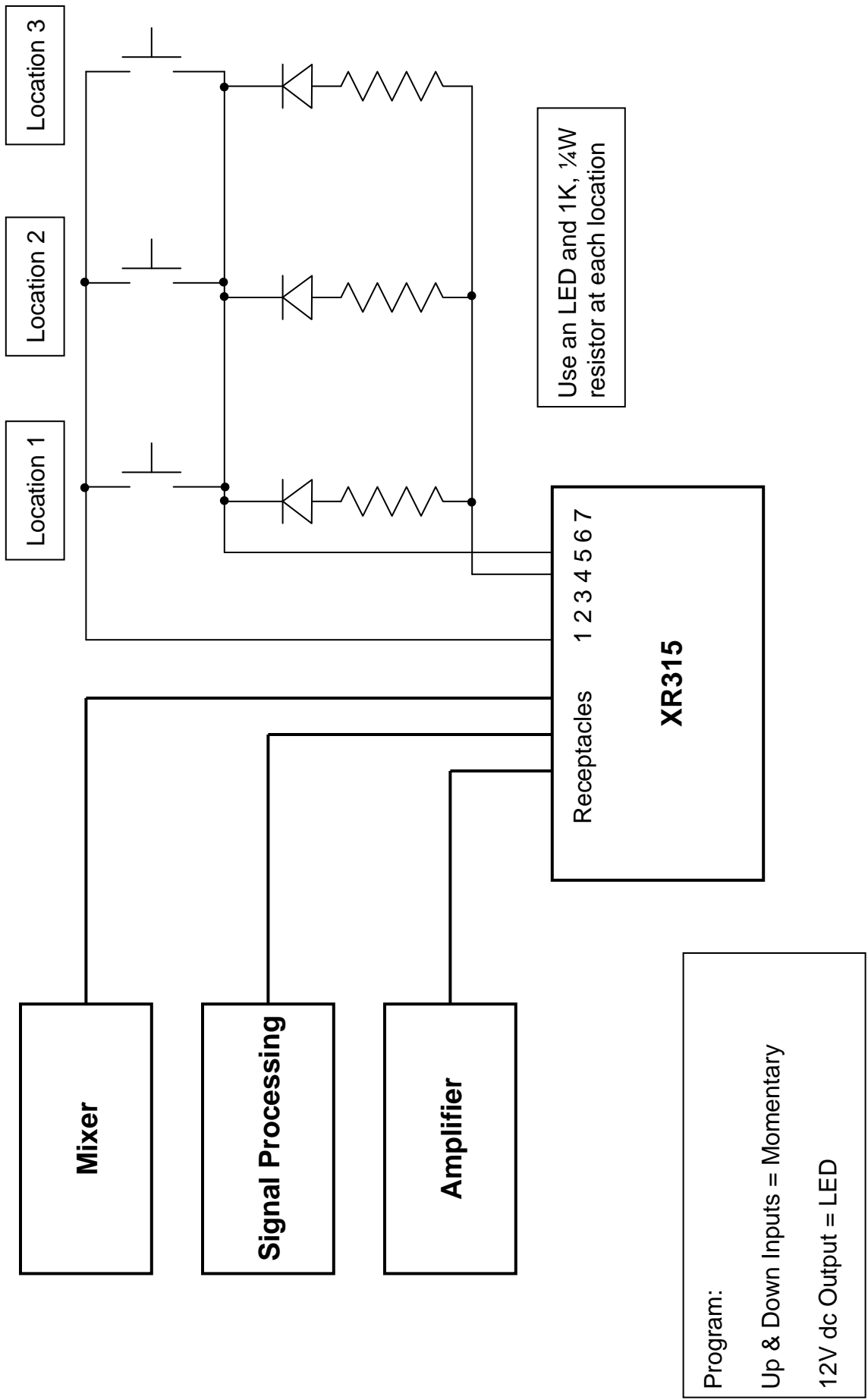

Figure 1

**Single-Unit System Controlled by Central Controller**

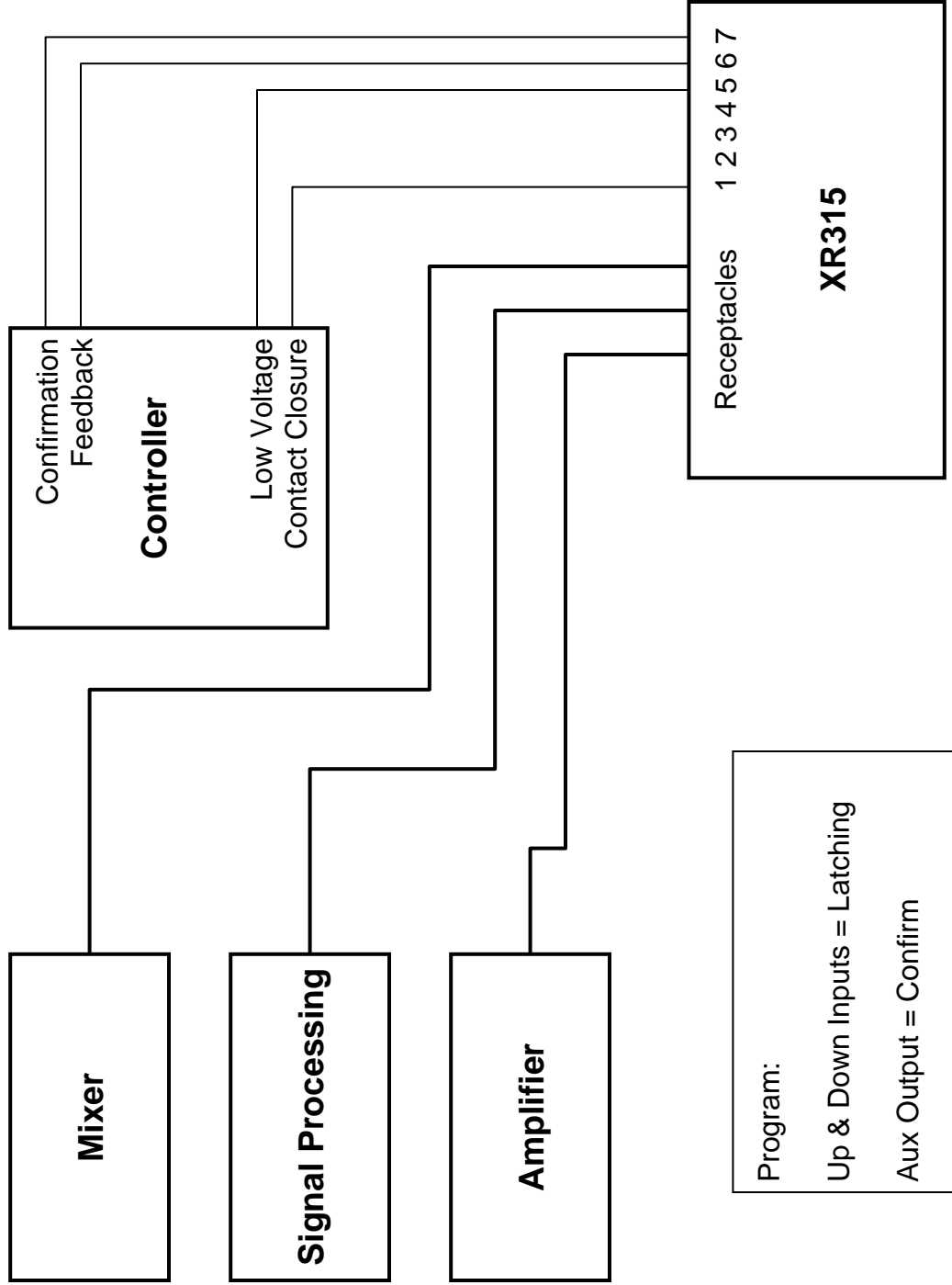

Figure 2

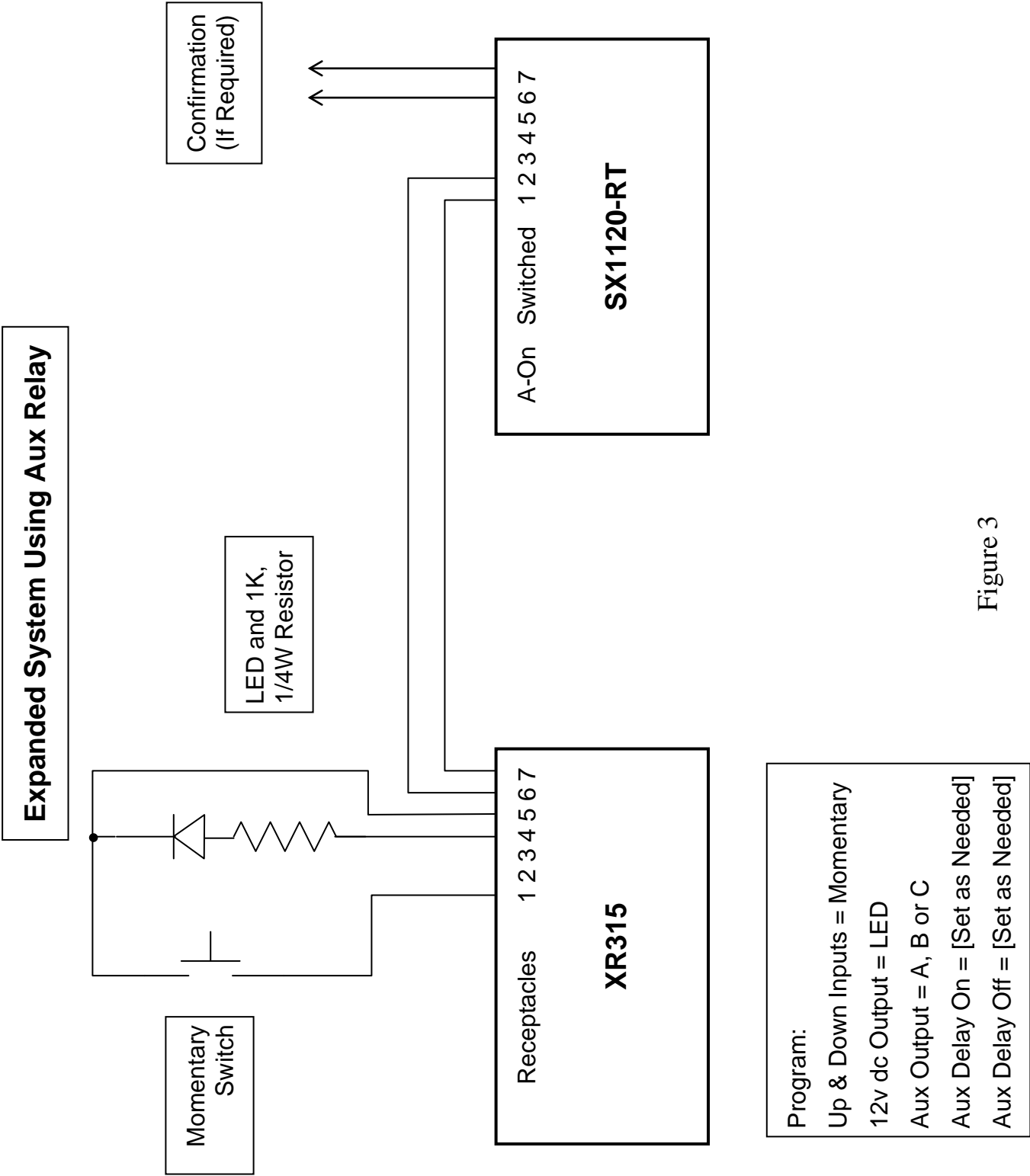
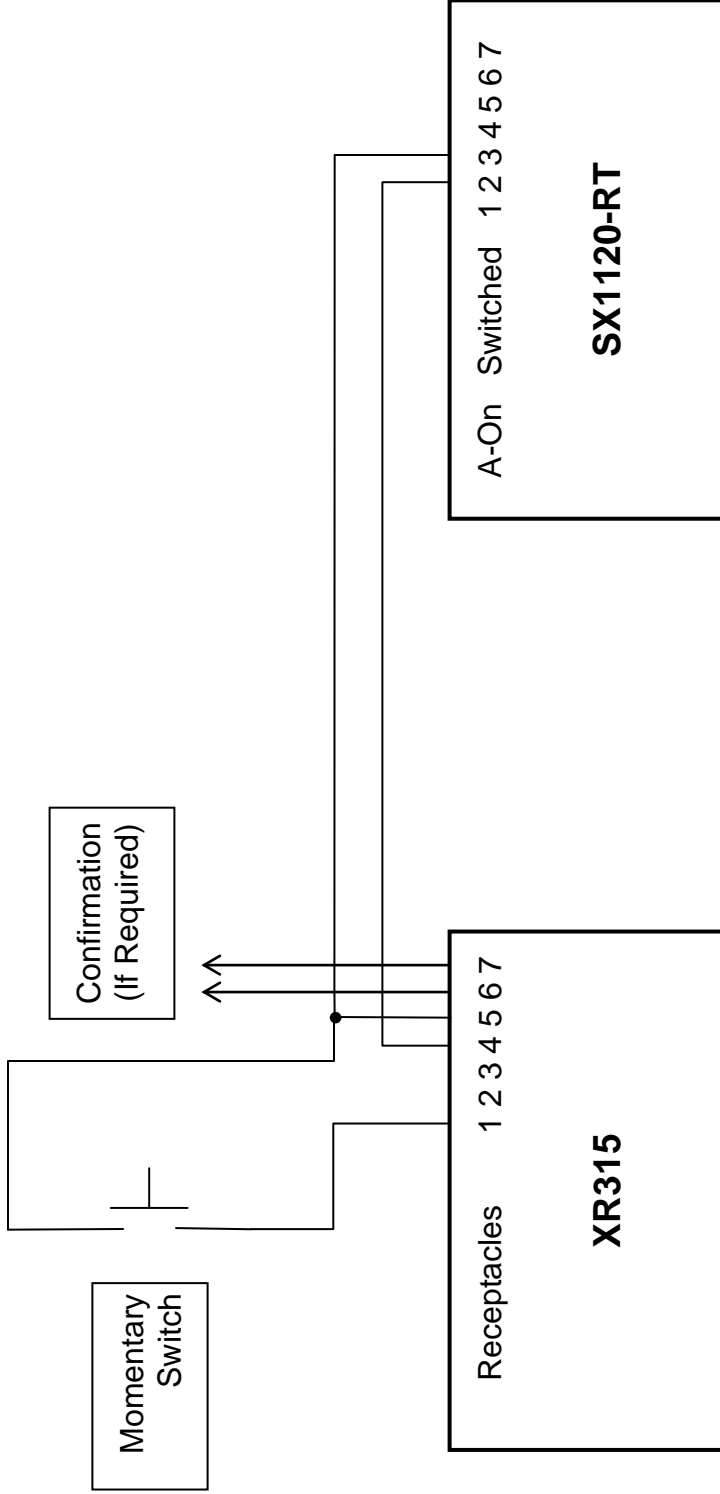

Figure 3

**Expanded System Using 12V dc Output**



**Program:**  
 Up & Down Inputs = Momentary  
 12v dc Output = A, B or C  
 12V Delay On = [Set as Needed]  
 12V Delay Off = [Set as Needed]  
 Aux Output = Confirm

Figure 4

**Three Units Ganged Together**

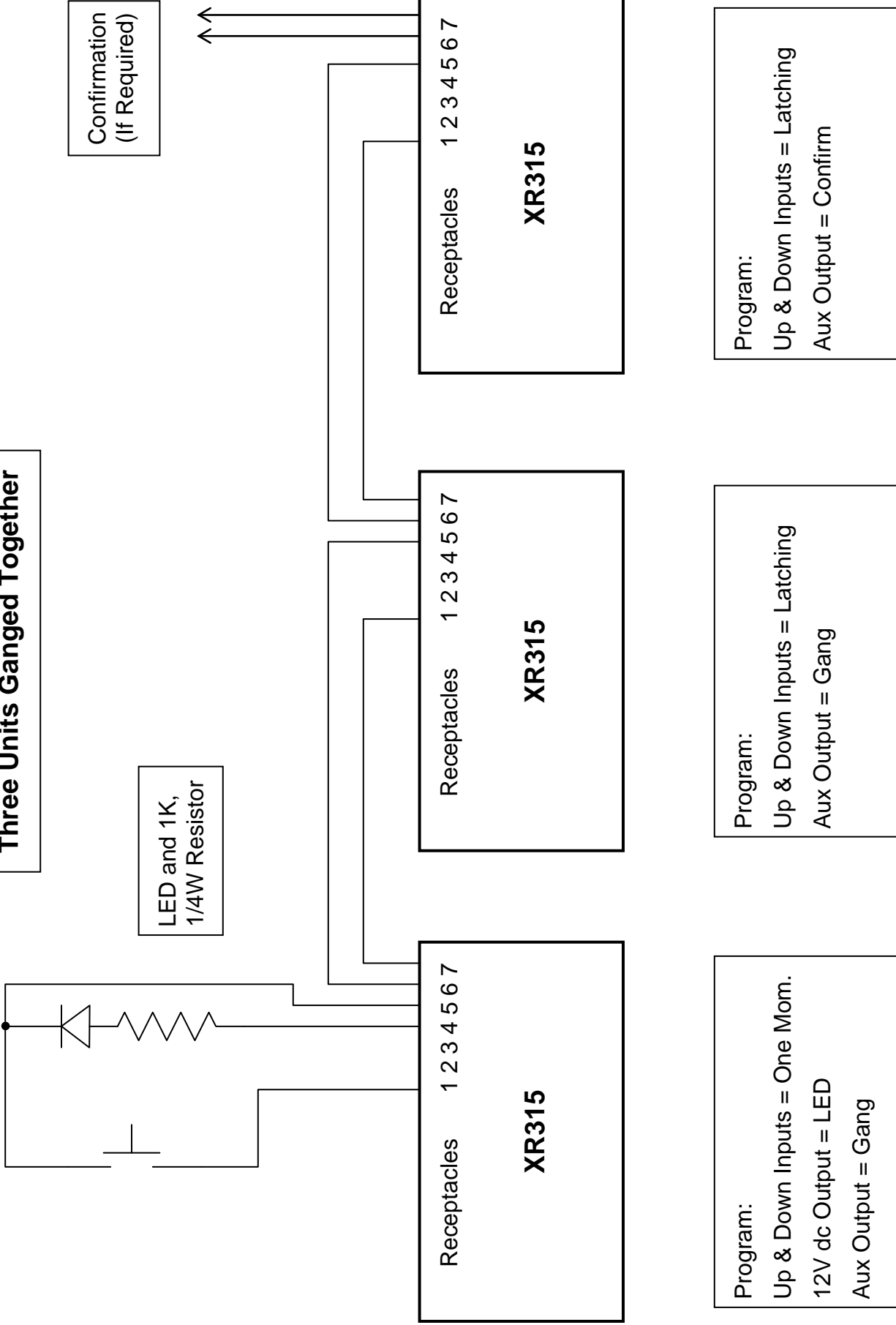

Figure 5

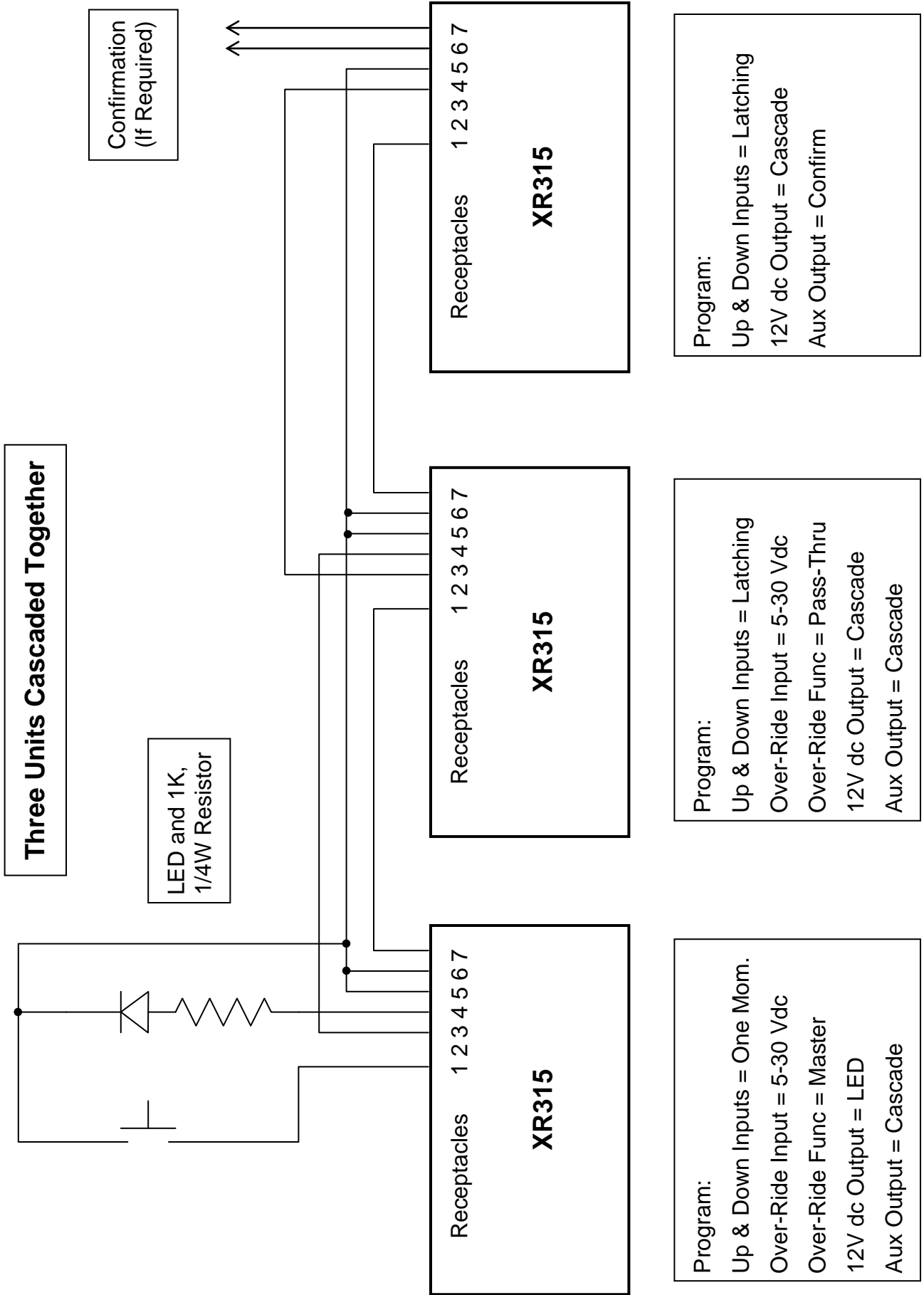

Figure 6

## **7 Troubleshooting**

### **Initial Check**

Whenever power is applied to the XR315 the LCD display should be illuminated and should show two lines of text as follows:

**OFF or ON 120V 0A** (or whatever the actual line voltage and load current are)

**Power: 0W** (or whatever the actual power calculation is)

If the first line of the display does not show “OFF” or “ON” the unit is in programming mode and therefore the receptacles will not turn on. Turn the Select rotary encoder counter-clockwise and then press the power button to get out of programming mode.

If the display is not illuminated, rotate the LCD Dimmer knob completely clockwise, or depress the LCD Backlight pushbutton.

If the display is not illuminated (and the Dimmer knob is fully clockwise or the Backlight pushbutton is depressed) and showing the above two lines of information, check that power is actually being supplied to the unit and that the breaker on the rear panel adjacent to the power cord has not tripped. If you are certain that power is being supplied to the unit, consult the factory for assistance.

### **Unit will not power up from remote control connection**

If you have performed initial checks as above and the unit will still not power up it could be because the “down” input (terminal 2) is being held active all the time. Remove the terminal block from the rear and check that the Up and Down signals are correct with a meter.

### **The front panel button will not work**

Check whether the front panel button has been programmed to Delay or Disable. If it has been programmed to Delay you must hold the button for one second before it will operate. If it has been programmed to Disable, it will not operate at all.

The front panel button will not work if the Up & Down Inputs have been set to Latching or 5-30V dc. This is due to the fact that a latching type input will always over-ride a momentary switch like the front panel button.

### **The unit powers up but will not power down**

Check the remote control connections using a meter and also the programming of the Up & Down Inputs. If Up & Down Inputs is set to Separate Up & Down and you are using a single momentary switch the unit will power up but not power down.

### **The unit starts to power up but then immediately powers down**

There are two likely causes for this: One cause is a Down input that is on all the time and overriding the power up function. Check the down input with a meter. The other cause is that the Over-Ride Func menu item has been set to Master when the unit is not actually connected to another XR315 and is in cascade mode. Change this menu item to Disable.

### **The unit will not go into programming mode**

You must power down the unit first before you can get into the programming mode.

## **8 Error Codes**

Error codes are displayed on the second line of the display.

**Error 05**      The calibration of the AC voltmeter is no longer accurate. The unit is otherwise fully operational. Call the factory for assistance.

**Error 15**      There is a checksum error in the non-volatile memory. This indicates that the set-up information could be incorrect. It is recommended that you completely check the programming and save the settings again. If error 15 is still displayed there is most likely a permanent problem with the non-volatile memory.

**Error 16**      There is an internal error. The unit will need to be returned to the factory for repair.

**Error 24**      Please call the factory.



## 9 Specifications

<b>Operational Voltage Range:</b>	90 to 150 Volts AC
<b>Current rating:</b>	15 Amps
<b>Power Rating:</b>	1,800 Watts
<b>Maximum Load Inrush Energy:</b>	1400 Joules total during power-up
<b>Surge Let-through Voltage:</b>	Zero let-through Voltage for a 6000 Volt surge
<b>Meets Federal Guidelines:</b>	Grade A, Class 1, Mode 1 (CID A-A-55818)
<b>EMI/RFI Filter, Normal Mode:</b>	40 dB @ 100 KHz, 50dB @ 300 KHz, 50 dB @ 3 MHz, 50 dB @ 30 MHz (50 Ohm load)
<b>EMI/RFI Filter, Common Mode:</b>	18dB @ 300 KHz, 30 dB @ 1 MHz, 50 dB @ 5 MHz, 50 dB @ 20 MHz (50 Ohm load)
<b>Maximum Applied Surge Voltage:</b>	6,000 Volts *
<b>Maximum Applied Surge Current:</b>	Unlimited (due to current limiting) *
<b>Maximum Applied Surge Energy:</b>	Unlimited (due to current limiting) *
<b>Endurance:</b>	(C62.41-1991 category B3 pulses), 1 KV > 500,000; 3 KV > 10,000; 6 KV > 1000
<b>Number of Outlets:</b>	8
<b>Remote Control Voltage:</b>	5 to 30 Volts dc
<b>Remote Control Current Draw:</b>	4 mA maximum
<b>Contact Closure Max. Resistance:</b>	100 Ohms
<b>Auxiliary Relay Contact Rating:</b>	30 Volts dc at 1 Amp
<b>12 Volt Output Max. Current:</b>	40 mA
<b>AC Voltmeter Accuracy:</b>	± 2%
<b>AC Ammeter Accuracy:</b>	0.1A resolution, ±1A accuracy

**Dimensions (no rack ears or feet):** 17.3" W x 10.5" D x 1.7" H

**Weight:** 12 lbs (5.4kg)

**Temperature Range:** 5C to 35C

**Humidity Range:** 5% to 95% R.H. Non-condensing

**Agency Listings:** ETL and cETL (UL 1449, Third Edition, Type 3 Surge Protective Device; UL 1283; CSA C22.2 No.8-M1986, R2004)

\* 1.2 x 50 microsecond industry standard combination wave surge as per IEEE C62.41

0208A