



205 Westwood Ave, Long Branch, NJ 07740
 Phone: 866-94 BOARDS (26273) / (732)-222-1511
 Fax: (732)-222-7088 | E-mail: sales@touchboards.com

Flat Screen Wall Mount / Full Motion

General Features

MAXIMUM LOAD: 35 kg (77 lbs)

DISPLAY COMPATIBILITY: Compatible with VESA LCD Flat screens with mounting hole configurations: 100x100mm, 200x100mm, 200x200mm, 300x200mm, 300x300mm, 400x200mm, 400x300mm, 400x400mm.

FASTENERS: All fasteners included.

WARRANTY: Limited 5 years (parts and workmanship).

Dimensions

Mounting Plate

- The Wall Bracket is to be installed vertically.
- The Wall Bracket can be mounted to either: Timber Stud Wall, or Masonry Wall.

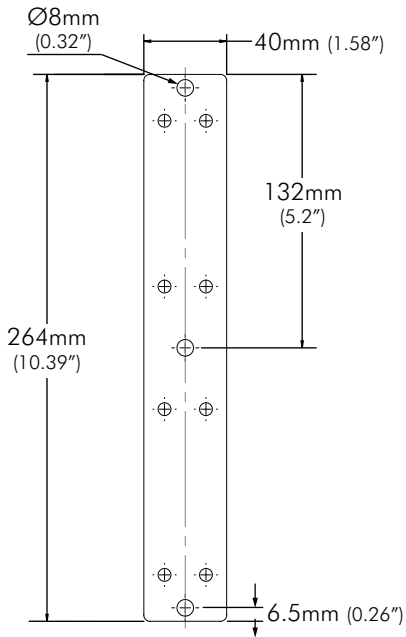

Articulated Arm Range of Movement

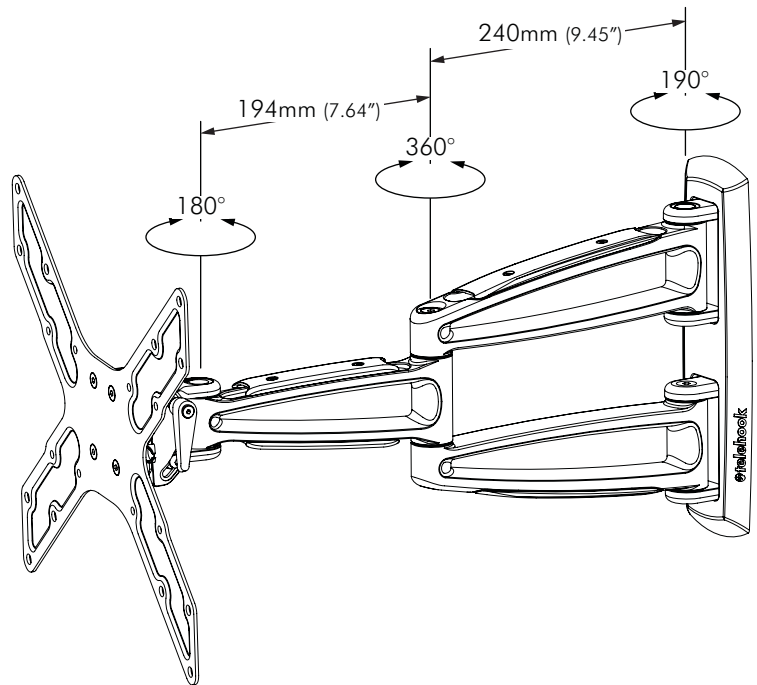

Distance from Wall

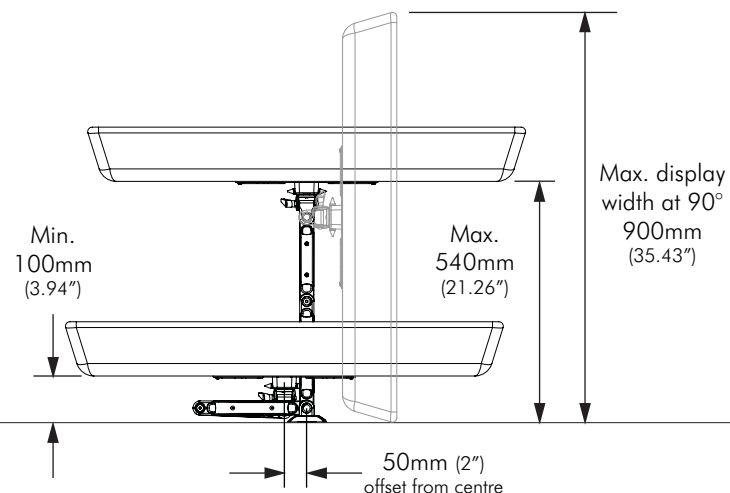

Side View

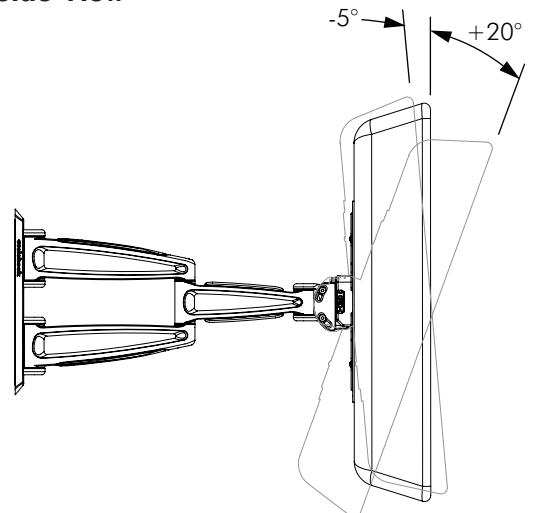

Dimensions (continued)

Front View

VESA mounting options:

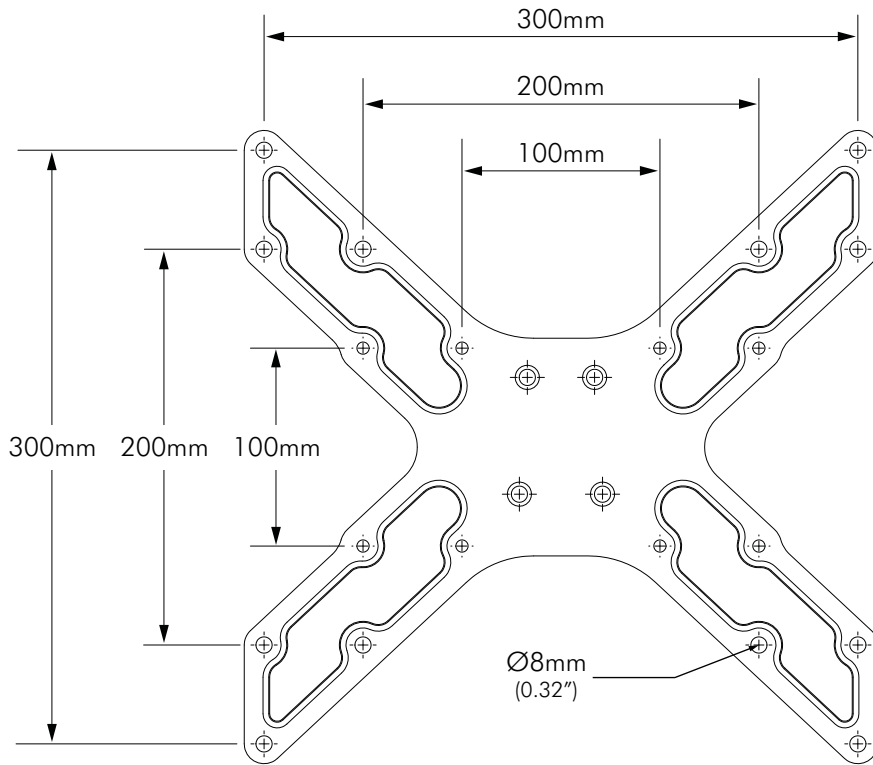

Extension Plate configurations:

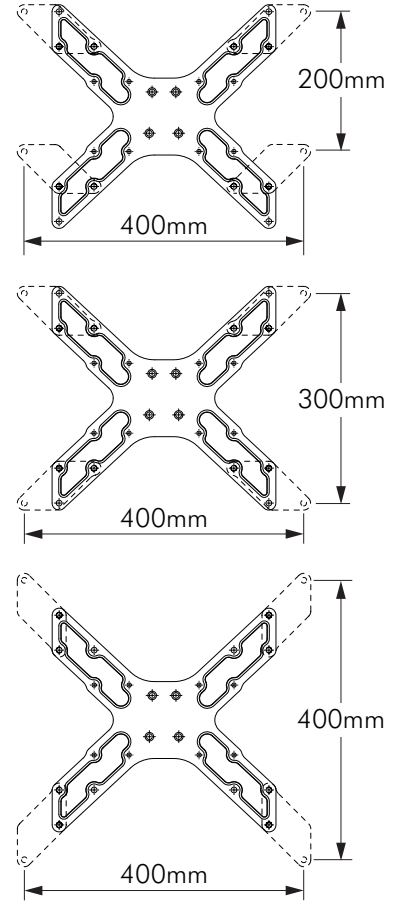

Range of Horizontal Movement

