

JBC

www.jbctools.com

INSTRUCTION MANUAL



TRA

Automatic Soldering Iron
for Robot

This manual corresponds to the following references:

- **TRA245-B** works with R245 cartridges
- **TRA470-B** works with R470 cartridges

Packing List

Either Ref. TRA245-B or Ref. TRA470-B is included.



Automatic Soldering Iron for Robot 1 unit



Manual 1 unit
Ref. 0027874

Assembly: GSFR Tube to SFR* and TRA*

1. Assemble SFR and the appropriate GSFR Guide Tube to TRA as described in SFR instructions manual.
2. Adjust TRA guide position in angle, height and length, then tighten the bolt to lock your settings.
3. Adjust TRA angle to its desired position by using the indicated bolt.
4. Adjust TRA guide arm position for your application by using the indicated bolt.

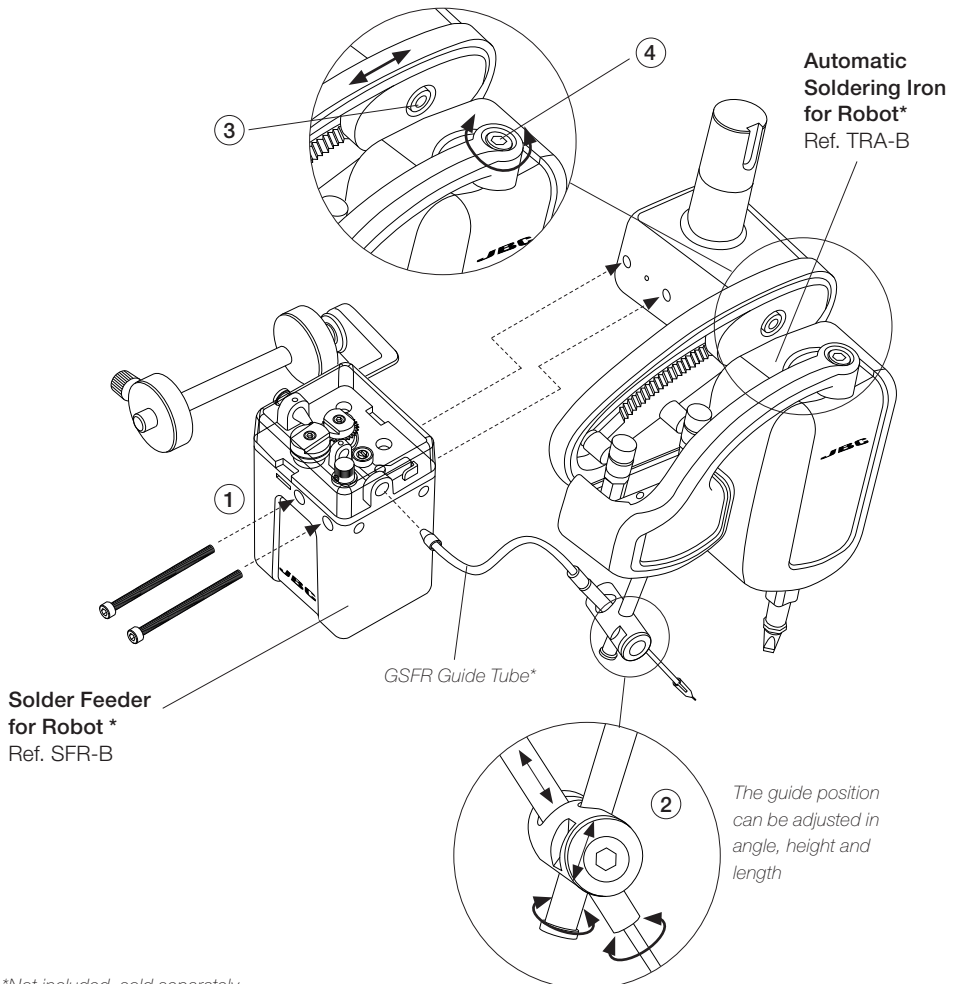

*Not included, sold separately

Connections

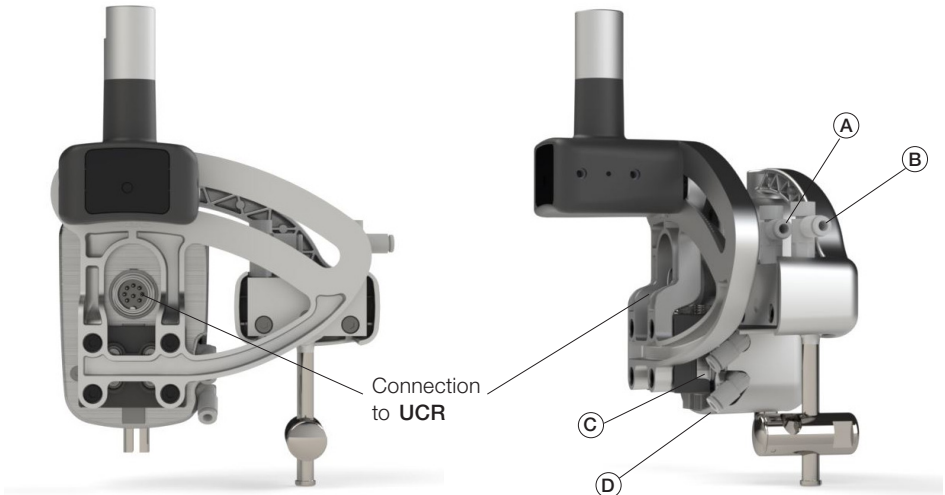

Gripper Actuator	
Fluid	Air
Applicable tubing	Ø4mm
Operating pressure	1,5 to 7 bar 20 to 100 psi

- (A) Air tube connection: Close arm to soldering position.
- (B) Air tube connection: Open arm to service position.
- (C) Air tube connection: Close grippers.
- (D) Air tube connection: Open grippers.

Note: JBC recommends bi-stable valves for the grippers to prevent the cartridge from falling out in case of an emergency stop or power cut.

Dimensions

TRA245-B

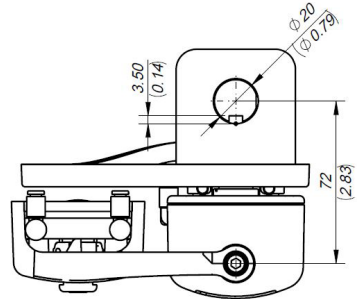
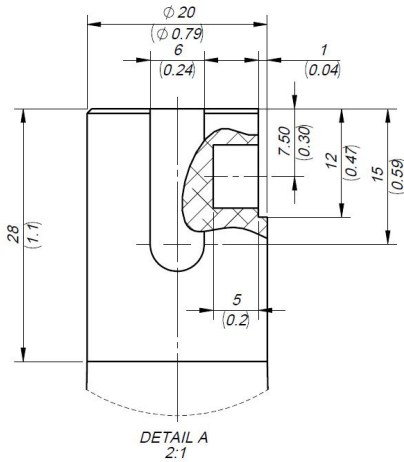
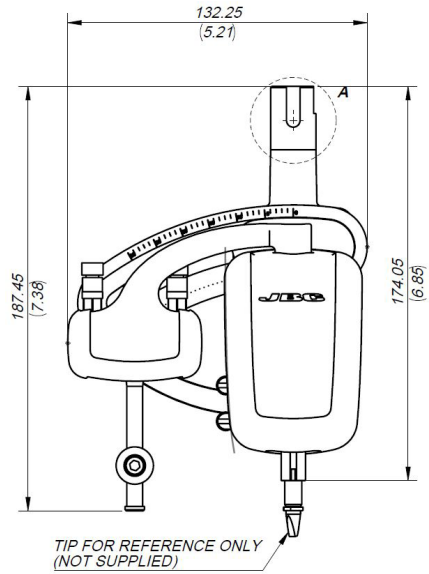
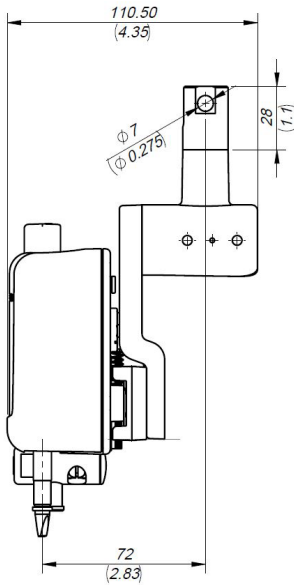

mm
(in)

Dimensions

TRA470-B

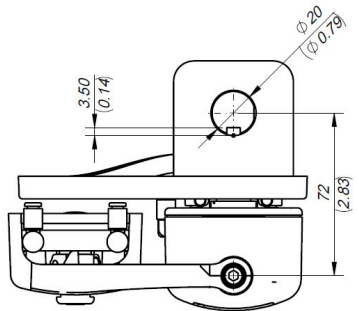
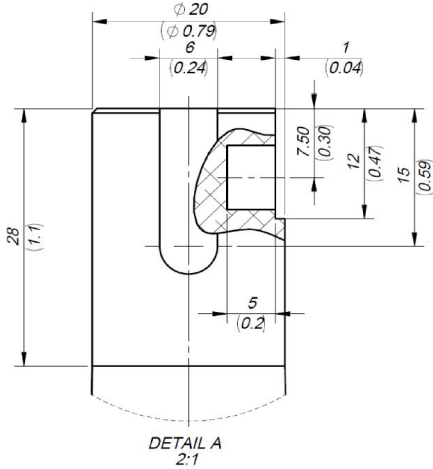
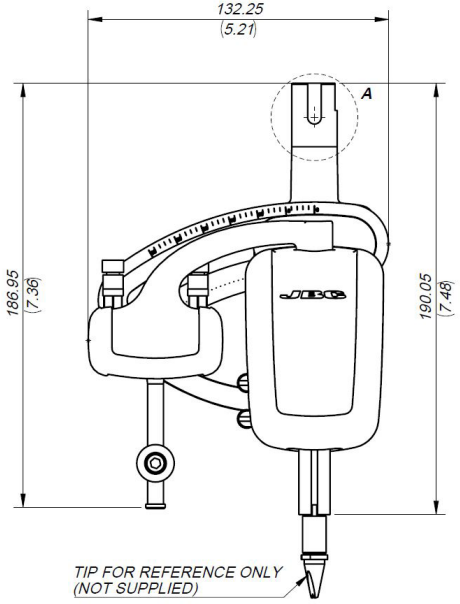
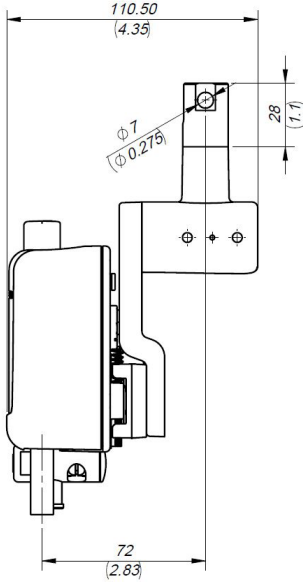

mm
(in)

Centering Jig

In order to align the CSR to your Soldering Head and set your cartridge pick-up points use JBC's Centering Jig.

Install both, lower and upper centering jigs, into CSR Cartridge Stand and HA Soldering Unit as shown.

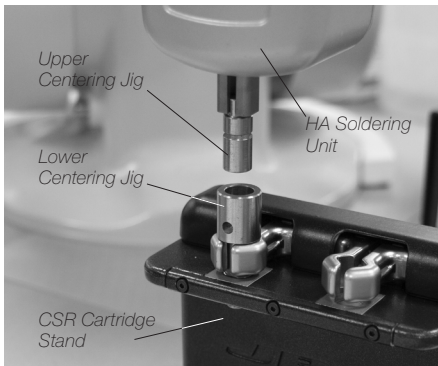

Adjust the Soldering Head position until the upper and lower centering jigs are aligned. It must be possible to move in and out smoothly.



Insert the centering jig completely. Set this point as the pick-up point position. The Soldering Head has to move in a vertical line from this point when inserting or removing cartridges.



Work Place Example

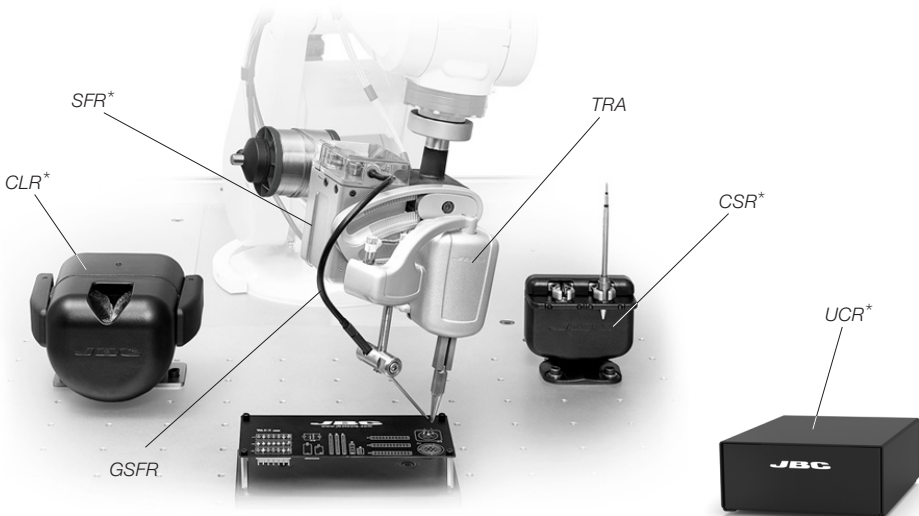

*Not included, sold separately

Compatibility

Soldering Irons	Cartridge Range		Control Unit		Cartridge Stand	
	R245	R470	UCR245	UCR470	CS2R245	CS2R470
TRA245	●		●		●	
TRA470		●		●		●

SFR, GSFR and CLMR are compatible with both R245 and R470 cartridges.

Maintenance

- Before carrying out maintenance, always unplug the tool.
- Use a damp cloth to clean the tool. Alcohol can only be used to clean the metal parts.
- Periodically check that the metal parts of the tool are clean so the control unit can detect the tool status.
- Periodically check all cable and tube connections.
- Maintain tip surface clean and tinned prior to storage in order to avoid tip oxidation. Rusty and dirty surfaces reduce heat transfer to the solder joint.
- Replace any defective or damaged part. Use original JBC spare parts only.
- Repairs should be performed only by a JBC authorized technical service.
- Under normal operating conditions, the air gripper lifespan is 10 million cycles. It is recommended to replace it at the end of its lifespan.

Safety



It is imperative to follow safety guidelines to prevent electric shock, injury, fire or explosion.

- Do not use the soldering iron for any purpose other than soldering or rework. Incorrect use may cause fire.
- Do not leave the appliance unattended when it is on.
- Be sure that the power supply is disconnected before changing any spare part.
- The temperature of accessible surfaces may remain high after the unit is turned off. Handle with care.
- Allow the cartridges to cool down before changing them.
- Heat can cause inflammable products to ignite even when not visible.
- Avoid flux coming into contact with skin or eyes to prevent irritation.
- Be careful with the fumes produced when soldering.
- Keep your workplace clean and tidy. Wear appropriate protection glasses and gloves when working to avoid personal harm.
- Utmost care must be taken with liquid tin waste which can cause burns.

Specifications

TRA

Automatic Soldering Iron for Robot

Ref.: **TRA245-B**

Ref.: **TRA470-B**

- Operating Pressure 1.5 to 7 bar / 20 to 100 psi

TRA245-A

- Total Net Weight: 700 g / 1.54 lb
- Package Dimensions/Weight: 221 x 136 x 126 mm / 909 g
(L x W x H) 8.70 x 5.35 x 4.96 in / 2.00 lb

TRA470-A

- Total Net Weight: 716 g / 1,58 lb
- Package Dimensions/Weight: 220 x 213 x 160 mm / 1000 g
(L x W x H) 8.66 x 8.39 x 6.30 in / 2.20 lb

Complies with CE standards.
ESD protected.

JBC

Warranty

JBC's 2 year warranty covers this equipment against all manufacturing defects, including the replacement of defective parts and labour.

Warranty does not cover product wear or misuse.

In order for the warranty to be valid, equipment must be returned, postage paid, to the dealer where it was purchased.



This product should not be thrown in the garbage.

In accordance with the European directive 2012/19/EU, electronic equipment at the end of its life must be collected and returned to an authorized recycling facility.



www.jbctools.com

0027874-0921