

Touchboards

205 Westwood Ave, Long Branch, NJ 07740
Phone: 866-94 BOARDS (26273) / (732)-222-1511
Fax: (732)-222-7088 | E-mail: sales@touchboards.com

Titan^{neo}



Portable Wireless UHF Sound System

Titan Neo

INTRODUCTION

Notes

Date of Purchase: _____

Model Number: _____

Serial Number: _____

Notes:

INTRODUCTION

Thank You

Congratulations on the purchase of your new Titan Neo Sound System. You can be assured that the Titan Neo was produced to high quality standards and will fulfill all its specifications. TeachLogic incorporated the latest state of the art technology, employed the most advanced manufacturing methodology and used only premium quality components to assure years of reliable service.

We appreciate your confidence in TeachLogic by your selection of our product. It is the intent of TeachLogic to uphold that confidence by offering you our direct assistance and customer support.

We hope you will take the time to review this manual to familiarize yourself with product features and guide you through its operation. This manual will explain the control functions and how to operate them. Also an explanation on how to setup and use the system so you will gain maximum benefit of the Titan Neo

The manual will conclude with recommended storage, maintenance and troubleshooting procedures.

Contact

If you should encounter some unresolved issue, please contact TeachLogic customer service department for further assistance.

☎ 1-800-588-0018

✉ sales@teachlogic.com

☎ 1-760-631-1283

🌐 www.teachlogic.com

Brian Van Waay

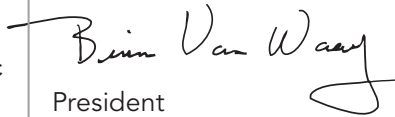

President

Titan Neo

INTRODUCTION

Safety Instructions

Read Instructions

All safety and operation instructions should be read before operating this TeachLogic product.

Retain Instructions

Safety and operating instructions should be kept for future reference.

Water & Moisture

This product should not be operated near water or excessively moist area.

Heat Environment

Do not subject this product to excessive heat conditions.

Power Source

This product must be connected to an AC power source per the voltage input specified and marked on the power supply.

Power Cord Caution

Power cable should be routed clear of foot traffic and supported clear of kinking or abrasion.

Object Protection

Locate the operating unit so it will not be subjected to falling objects or water entry.

Proper Installation

Adhere to safe positioning to avoid falling, dismounting, head clearance, or cord cable obstruction

Internal Service

User should not attempt to service this product. A qualified technician must accomplish all internal service.

Electric Shock

Do not adapt or modify the AC power plug thus lifting the earth ground connection.



CAUTION

**RISK OF ELECTRIC SHOCK:
DO NOT OPEN**

Caution: To Reduce The Risk Of Electric Shock Do Not Remove Cover (Or Back)
No User-serviceable Parts Inside
Refer Servicing To Qualified Personnel

Certifications



Listed



TeachLogic systems are manufactured using lead-free processes and are free of materials harmful to the environment. They conform to the most stringent new European guidelines for consumer products (RoHS).

Caution

Recycle—Do not dispose of rechargeable batteries in trash. Actually it is unlawful to do so in CA, NY & ME.

Contact: Earth911.com
1-800-CLEANUP

Save our resources and don't contaminate.
Go Green

INTRODUCTION

Table of Contents

Introduction	i-7
Titan Neo Components & Operation	
General Description	8-10
Main Control / Input Panel	11
DR-800 Auto Scan Receiver	12
DR-850 Dual Channel Receive	13
BT-800 Bluetooth Wireless	14
CD-800S CD/MP3 Player	15-16
CD/MP3 Remote Control	17-19
TX-800 Transmitter Module	20
PA-810 Companion Speaker	21
DD-800 Digital Delay Module	21
UR-96 BP Body-Pack Receiver	22
Transmitter/Microphones	
UT-96BP Body-Pack Transmitter	23-25
UT-96HH Handheld Transmitter	26-27
Battery Chargers	28-29
Troubleshooting Microphones	30-32
Frequency Charts	33-36
Specifications	37-39
Accessories	40
Warranty	41

INTRODUCTION

About RF Transmission

Through today's technology and advanced engineering, wireless microphones reproduce excellent vocal quality and render very reliable service. Thus today, the use of wireless microphones is commonplace. The convenience of no cumbersome cables and freedom of movement has made the wireless microphone very convenient to use.

However, it will be helpful to be aware of some inherent anomalies associated with wireless microphones. RF is a radio signal being transmitted from the microphone to a receiver in your sound system. Note; there are thousands of RF signals being transmitted through the air at all times. Therefore, it is always possible that there may be another signal being transmitted at or near the frequency you have selected. This will cause interference resulting in static, intermittent connection or even complete blockage. Therefore, a change in frequency selection will be necessary.

Extensive metal barriers (cyclone fences, screen, steel reinforced walls, etc.) can reduce signal strength, resulting in dropouts and poor performance.

RF can transmit through solid surfaces in all directions. The range can be in excess of 100 feet. Therefore, be aware that what is said off stage will be heard unless the transmitter is turned "off" or microphone is muted.

The most troublesome problem with wireless microphones is the result of weak batteries. Typically, fresh alkaline batteries will provide 6 - 8 hours of service and rechargeable batteries 5 - 7 hours per charge.

INTRODUCTION

About the Titan Neo

The Titan Neo is a compact portable sound system for music playback and voice reinforcement. It is powered by internal batteries and housed in a rugged enclosure. The lightweight, compact size makes the Titan Neo very versatile and practical for use on all occasions, indoors or out.

The basic system is comprised of an efficient 50 watt power amplifier, a control panel and a rechargeable battery power supply. The control panel provides a battery level indicator, microphone input with volume control, line input with volume control, line output, master volume, and bass and treble controls. The rechargeable NiMH batteries provide 6–8 hours of use at moderate sound level. Titan Neo can also be plugged into AC for continuous use.

With the "Priority" function switch on the control panel engaged, while playing music through the system, the music volume will automatically be lowered 15 dB when speaking into the microphone. After speaking, the music will automatically restore to the previous level.

The Titan Neo can be equipped with several options. One or two wireless microphone receivers can be installed; expanding its capability for use with wireless microphones.

Either a CD/MP3 player for playback of CD / flash drive or a digital MP3 only module can be installed. A unique option, the wireless AirLink module, will transmit the composite program from one Titan Neo to another Titan Neo equipped with a wireless microphone receiver—equivalent to having a powered remote speaker without a cable connection (multiple units can be used).

The Titan Neo is equipped with a neodymium bass speaker that provides greater efficiency, better sound quality, and lighter weight. Coupled with a high frequency horn, the Titan Neo reproduces a full range sound with crystal clear voice projection.

Titan Neo

Titan Neo COMPONENTS & OPERATION

Titan Neo Rear

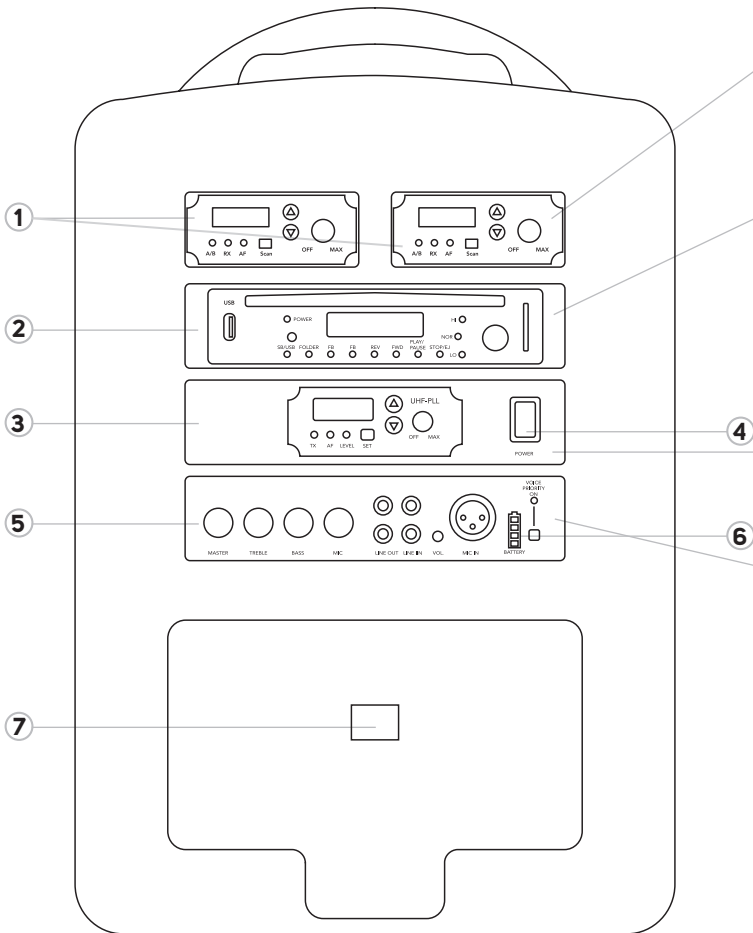

- 1 Optional DR-800 Receiver Modules
- 2 Optional CD/MP3 Player Module
- 3 Optional TX-800 Transmitter Module

- 4 Power Switch
- 5 Main Control Panel
- 6 Charge Indicator Light
- 7 110-240v AC Input

Titan Neo COMPONENTS & OPERATION**Receiver Module for Wireless Microphone Model: DR-800**

The DR-800 module is a 96 channel UHF receiver (640 – 664 MHz). The auto scan feature will automatically select a clear channel and lock on. However, the user can override the auto and manually select a channel of choice. Two DR-800 modules can be installed for dual wireless microphone operation.

CD/MP3 Player Module with Remote Control Model: CD-800S

In addition to being an anti shock CD / MP3 player it also features a USB Input Port and SD/MMC Reader. The pitch can be increased or decreased 10 levels up or down. Controls and functions include: Volume, Play/Pause, Stop/Eject, FWD, Rev, FF, FB and folder select. A fully functional remote control with Keypad provides remote operation of all functions.

AirLink Transmitter Module Model: TX-800

For larger venues or audiences, the TX-800 transmitter module will broadcast a composite program signal to companion units equipped with a DR-800 wireless receiver. The companion systems can be located throughout the venue without the need for speaker cables. The TX-800 will transmit all inputs including the wireless microphones, CD player, and control panel inputs. Typical operating range is 300–500 feet (line of sight).

Main Control Panel

The control panel provides the basic inputs and controls. Inputs include: Balanced (XLR) or Unbalanced (1/4" phone) Lo-z microphone Input, Dual Line Input (RCA) with volume control, Dual Line Output (RCA), Mic. Volume Control, Treble & Bass Controls, Master Volume Control, Battery Level Indicator, and Voice Priority Switch.

Digital Time Delay Module Model: DD-800

Installed in Companion System only

The DD-800 module is a delay module that can store a signal received for 20–500 milliseconds, selectable in 2 millisecond increments. The program signal is transmitted from the Titan Neo through the TX-800 AirLink Module to the companion system equipped with the DD-800 delay module. The signal is digitally stored in the DD-800 per the delay time selected and then released through the companion sound system. Its purpose is to synchronize the sound heard from the master Titan Neo with the sound from the companion system. Typical application, when companion system is more than 50 feet away.

Titan Neo

Titan Neo COMPONENTS & OPERATION

Before Using the Titan Neo

It is best to plug the Titan Neo into an AC outlet and restore batteries to full charge condition. Although the batteries were checked and fully charged prior to shipment, NiMH batteries have a tendency to lose some charge when not in use.

Nickel Metal Hydride Battery (NiMH) (environmentally friendly)

The NiMH battery is the present day replacement of the (NiCd) Nickel Cadmium battery. Its energy density is more than double that of Lead Acid and 40% higher than NiCd batteries thus serving a longer performance per charge. Relative to size, weight, and capacity; the NiMH battery is the best performing and cost effective battery for portable applications. Typical life expectancy is three to five years and will provide approximately 500 hundred full recycles.

Battery Care and Maintenance

Inherent to NiMH batteries, they are prone to self discharge while not in use. Therefore, it is best to plug the Titan Neo into an AC outlet while in storage. This will assure full useable charge and ready to use. The regulated power supply of the Titan Neo will maintain a full charge and not overcharge the batteries. Although the NiMH battery does not form a memory like the NiCd, they can form a bit of a barrier at lower discharge levels. It is a good practice to totally discharge and recharge the batteries once or twice a year to maintain full service per cycle.

Four Level Battery Indicator

Top LED (Green)	80 – 100% Charge
Second LED (Green)	50 – 80% Charge
Third LED (Yellow)	20 – 50% Charge
Bottom LED (Red)	0 – 20% Charge



Power Panel

The power panel is located above the main control panel. Its houses the master power switch. The internal light in the rocker switch will illuminate "red" when powered "on".

When either the AirLink (TX-800) or Digital Delay (DD-800) module is installed in lieu of the power panel, the power switch is part of its panel.

Titan Neo COMPONENTS & OPERATION

Main Control Panel

The main control panel is the basic panel for all Titan Neos and Titan Neo companions. It houses the master volume control, hardwired microphone input, auxiliary input, record output, mic & line volume controls, tone controls and the unique "Voice Priority" switch.

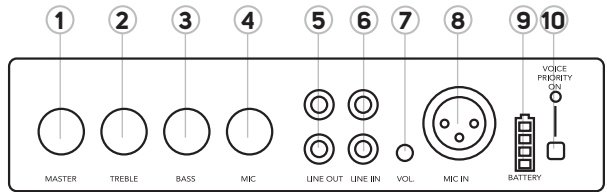

- | | |
|---|---|
| <ul style="list-style-type: none"> 1 Master Volume Control 2 Treble Control 3 Bass Control 4 Wired Mic. Volume Control 5 Dual Line Output (RCA) 6 Dual Line Input (RCA) | <ul style="list-style-type: none"> 7 Line Input Volume Control 8 Cabled microphone input <ul style="list-style-type: none"> • Balanced Lo-z (XLR) • Unbalanced Lo-z (¼ phone) 9 Four Level Battery Indicator 10 Priority Override Switch |
|---|---|

Basic Operation Using a Cabled Microphone

1. Plug in a cabled Lo-z microphone, either a 3-prong XLR or ¼" phone connector.
2. With mic and master volume controls at zero, switch power "on".
3. Battery level indicator should read "Green" indicating the useable battery level.
4. Turn master volume to mid scale.
5. Slowly turn mic volume up while talking into microphone.
6. If additional volume is required, increase master volume.
7. Adjust tone controls.
 - Treble boost improves voice projection, especially outdoors.
 - Bass boost consumes more battery power.
8. To playback music, plug an external audio source such as an iPod or MP-3 player, into the dual RCA line input jacks.
9. With the audio source playing, adjust the volume to desired level.
10. Push in "Voice Priority" switch, "red" LED will light.
11. While audio source is playing, talk into microphone.
12. You will note: the volume of the playback will decrease 15 dB while you speak into the microphone and will automatically return to previous volume after announcement.
13. To record or feed a composite program to another system, plug into the dual RCA line output jacks.

Titan Neo

Titan Neo COMPONENTS & OPERATION

DR-800 Auto Scan Receiver for Wireless Microphone

One or two auto scan receiver modules can be installed in the Titan Neo. Each receiver has 96 selectable channels to assure interference-free operation and is equipped with a diversity antenna for added sensitivity.

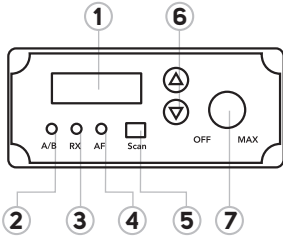

- 1 LCD Display: Ch. # or Freq. Readout
- 2 RF Reception: Diversity A/B Antenna (Red or Green)
- 3 Transmission Signal Present Indicator (Blue)
- 4 Flashing - Audio Level Being Received (Green)
- 5 Channel Scan
- 6 Channel "Up/Down" Selector
- 7 Receiver Module: "on/off" and Master Gain

Operation

Auto Scan Receiver

1. Turn receiver "on", turning volume/power switch clockwise to 12 o'clock.
2. The receiver will display the last channel previously selected.
3. To scan for a clear channel push the "Scan" button. The LCD screen will display "SCAN" while searching for first available open channel/frequency. The receiver will lock on and display the cleanest available channel.
4. Tune the transmitter frequency to match the displayed channel on the receiver to begin operation.

Manual Tuning

1. Press and hold the "Up or Down" selector until the channel number blinks.
2. Press the "Up or Down" button until the desired channel is selected.
3. The receiver will stop blinking and lock into the selected channel.

Continue Tuning

1. The auto scan receiver is now ready to receive signal from a wireless microphone for AirLink transmitter. Tune the transmitter frequency to match the displayed channel on the receiver to begin operation.
2. When receiving a transmission signal, the A/B diversity antenna LED will illuminate "Red or Green" indicating antenna selection.
3. RX indicator will illuminate "Blue", indicating reception of signal from transmitter.
4. AF indicator will flash "Green" when receiving an audio signal.

Titan Neo COMPONENTS & OPERATION

DR-850 Dual Channel RF Receiver for Wireless Microphone

One or two *dual channel* receiver modules can be installed in the Titan Neo. Each receiver has 96 selectable channels to assure interference-free operation and is equipped with a diversity antenna for added sensitivity.

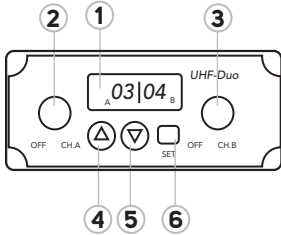

- 1 LCD Display: Ch. # or Freq. Readout
- 2 Receiver Ch.A "on/off" and Master Gain
- 3 Receiver Ch.B "on/off" and Master Gain
- 4 Channel "Up" Selector
- 5 Channel "Down" Selector
- 6 Channel/Set Selector

Operation

Dual Channel Receiver

- Tuning single receiver

Tuning single channel

1. Turn receiver Ch.A or Ch.B "on", turning volume/power switch clockwise to 12 o'clock.
2. The receiver will display the last channel previously selected.
3. To select a different channel press the "SET" selector until the light blinks. Using the "UP / DOWN" buttons search for the desired channel. Press the "SET" selector again until the light stops blinking.
4. Tune the transmitter frequency to match the displayed channel on the receiver to begin operation. The receiver will display the signal strength of the transmitter .

- Tuning two receivers

- With two receiver turned on, the SET switch operates as a mode switch.
- The first press controls functions on the "A" receiver.
- The next press controls functions on the "B" receiver.
- The next press sets the receivers to normal operate mode.
- Each consecutive press will repeat the cycle.

Titan Neo COMPONENTS & OPERATION

BT-800 Bluetooth Wireless Receiver Module

One BT-800 Bluetooth receiver module can be installed in one of the two receiver slots at the top of the Titan Neo.

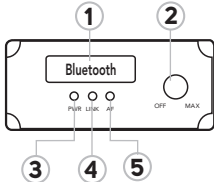

- 1 LCD Display: Bluetooth Readout
- 2 Receiver Module: "on/off" and Master Gain
- 3 Power Indicator
- 4 Transmission link Indicator
- 5 Audio input Indicator

Operation

Bluetooth pairing

1. Turn Bluetooth "on", turning volume/power switch clockwise to 12 o'clock.
2. The receiver will highlight Bluetooth Logo indication power on.
3. PWR indicator will light.
4. Go to Settings on your Bluetooth device. Select Bluetooth from menu, Search for "devices", Select "Portable PA". Receiver and transmitter will begin pairing process.
5. LINK indicator will illuminate when pairing is complete.

Titan Neo COMPONENTS & OPERATION

CD-800S Player

This anti-shock CD/MP3 player allows playback of both standard CD's and data CD's containing MP3 or WMA files.

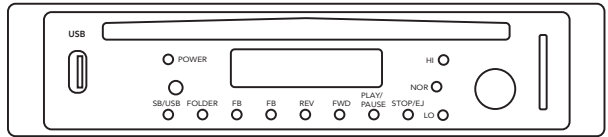

To operate, push the power button. Insert a CD into the CD slot and press play/pause button.

1. Adjust volume to desired level.
2. To skip forward a whole track press the next track button (>>|). To skip backwards a whole track, press the previous track button (|<<). To search through tracks, press and hold either of these buttons until you reach the desired point in the track.
3. Repeat allows repeating of single songs or all songs. Shuffle plays tracks in a random order.
4. To program specific tracks for playback press the track program button. Select the song you wish to program on the disc using the next track (>>|) and previous track buttons (|<<). Press repeat to enter the track into the program. Repeat as necessary. To playback programmed tracks press the play/pause button. Note: program will be reset whenever the track program button is pressed.
5. For use with MP3 discs you can select folders of music on the CD. Press the folder button and use the next track (>>|) and previous track buttons (|<<) to select your desired folder. Note: this function searches the disc in alphanumeric order.

Note

For optimum performance a professionally manufactured CD should be used. However, if you are playing a CD/R, burn music at the slowest rate for best playback results.

Titan Neo COMPONENTS & OPERATION

CD-800S Player Functions

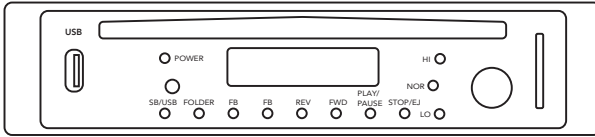

POWER

- **ON:** Press Power to switch on the power.
- **OFF:** Press and hold Power to switch off the power.

LCD DISPLAY Displays CD status including track number and playing time.

SD/USB/CD Press this key to change USB, SD or CD mode.

FB Select fast backward. Then press "PLAY/PAUSE" for normal playback.

FF Select fast forward. Then press "PLAY / PAUSE" for normal playback.

FOLDER Selects pre-programmed folders. Available when playing MP3 format files. Press FOLDER key again to advance to next folder.

REV Press to desired previous track number.

FWD Press to desired next track number.

PLAY/PAUSE Press once to play, press again to pause.

STOP/EJECT Press to stop playing, press again to eject disc.

Infrared window Picks up signal from the remote controller.

USB Connector Accepts USB Drive

SD Connector Accepts SD Card and MMC Card.

LO-PITCH To adjust slow-speed play. Press once, the screen will indicate PH-01, press again, the screen will indicate PH-02. There are 10 steps of speed variation.

HI-PITCH To adjust fast-speed play. Press once, the screen will indicate PH-01, press again, the screen will indicate PH 02. There are 10 steps of speed variation.

NOR-PITCH To adjust the speed to zero. Press NOR/PITCH key, the speed will be zero back to normal play.

Titan Neo COMPONENTS & OPERATION

CD-800S LCD Display

CD When in CD mode, the display panel shows "Cd".

USB When in USB mode, the display panel shows "USB"

SD When in SD mode, the display panel shows "Sd"

PLAY When in play mode, the display shows "▶"

PAUSE When paused, the display shows "||"

REPEAT When repeatedly playing the single track, it shows "REPEAT 1".

REPEAT ALL When all tracks are playing repeatedly, it shows "REPEAT ALL".

REPEAT FOLDER When all tracks in a specific folder are playing repeatedly, it shows "REPEAT FOLDER".

SHUFFLE Will playback Random tracks.

MEMORY When playback programmed tracks.

PROGRAM Will program tracks.

A→B Will continuously loop a track between selected point A and B.

▣▣ Under the MP3 mode, it will appear the folder numbers.

▣▣▣ Display the current playing track.

▣▣:▣▣ Display the time for the current playing track.

VOLUME Turn to adjust & control the desired volume.

Note

When using the remote control, the remote should be pointed toward the face plate of the CD/MP3 Player. The optimal receiving distance is 10 feet.

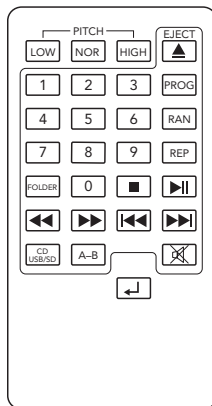











Touchboards

205 Westwood Ave, Long Branch, NJ 07740
 Phone: 866-94 BOARDS (26273) / (732)-222-1511
 Fax: (732)-222-7088 | E-mail: sales@touchboards.com

Titan Neo COMPONENTS & OPERATION

Playing CD-800S

- This player will accept 4.75" (12 cm) discs like CD, CD-R, CD-RW, MP3, USB and SD / MMC memory cards, but will not play CD-ROM / CD-I / CDV, or 3" (8 cm) discs.
- The CD player will accept MPEG-3 (MP3) and WMA format files.
- Insert a disc into disc slot with the playback side down, playback starts automatically. Track number and playing time will be displayed. 
- To pause playback or start normal playback, press PLAY/PAUSE or press on the remote controller.
- Press REV, F.WD, or   on the remote controller, to select previous or next track. CD player will continue playback while displaying selected track.
- To stop playback, press STOP/EJECT or press  once on the remote controller.
- To eject CD press STOP/EJECT once to stop playback. Press again to eject CD. Or press  on remote controller.
- Press FB, FF or   on the remote controller, to activate fast back or fast forward until desired selection is located.
- Press LO, NOR, HI/PITCH or    on the remote controller to adjust low, normal and high playback pitch.
- Press FOLDER or  on the remote controller, will select the next catalogue of tracks to be played.

Playing SD/MMC Card

- Insert SD Card or MMC Card into the insert hole of SD/MMC CARD in the face plate. Push the card into the SD/MMC card slot. To remove the card, please push the card to the bottom and then release. Please do not use force to pull card out. Pulling the card will damage the card and/or machine.
- Press SD/USB/CD or SD/USB/CD on the remote controller. Select SD then press PLAY/PAUSE or  on the remote controller to play.

Playing USB Drive

- Insert USB into the insert hole of USB in the face plate.
- Press SD/USB/CD or SD/USB/CD on the remote controller.
- Select USB then press PLAY/PAUSE or  on the remote controller to play.

USB Input will not accept audio from iPod, iPad or iPhone. You may connect an mp3 from the device headphone jack to the Titan RCA inputs

Titan Neo COMPONENTS & OPERATION

Remote Controller Functions

EJECT Press  to stop playing and eject the disc.

PROG can memorize a set of tracks for playback.

To Program a set of tracks:

- 1) Insert a disk into the CD player, press **PROG** key one time.
- 2) Enter the folder and track number then press  to confirm selection.

For example: To program track 23 then 42 then 19, Press 0 and 1 for folder, the LCD will display "01". Then press 2 and 3 for track number, the LCD will display "23". Then press  to confirm selection, the LCD will display "01 23:01". This is Folder number 1, track number 23, first selection to play.

Then press 4 and 2 for track number, the LCD will display "42 :02" for track number and selection number 2. Then press  to confirm selection, the LCD will display "01 42:02".

This is Folder number 1, track number 42, second selection to play.

Then press 1 and 9 for track number, the LCD will display "19 :03" for track number and selection number 3. Then press  to confirm selection, the LCD will display "01 19:03".

This is Folder number 1, track number 19, third selection to play.

- 3) Repeat this process until all desired tracks have been memorized.
- 4) When all selections have been memorized press .

RAN A random selection of tracks will play. Press **RAN** and the LCD will display "SHUFFLE".

REP **REPEAT MODE**. While playing a CD, press **REP** once, the LCD will display "REPEAT ALL". Repeat All will repeat all tracks one time. Press **REP** again, the LCD will display "REPEAT 1". Repeat 1 will repeat all songs in that folder. Press **REP** a third time, all repeats will be cancelled.

Replacing Remote Battery

1. Pull battery clip
2. Insert battery
3. Replace clip

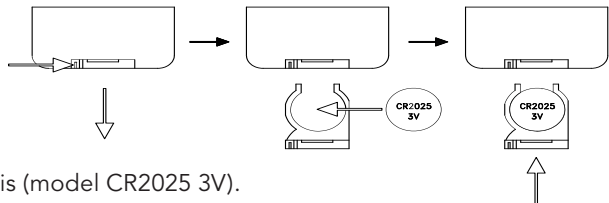

The battery for the remote is (model CR2025 3V).

Titan Neo COMPONENTS & OPERATION

TX-800 Transmitter Module

For larger venues or audiences, the addition of this module allows several units to be used in the same area without the need for speaker or signal wiring. In this application you have a master and as many slave units as required for the venue. The wireless AirLink module is installed in the master unit, which then transmits any audio signal (including wireless mic, CD player or wired mic) to the slave units, which are fitted with a UHF wireless receiver.

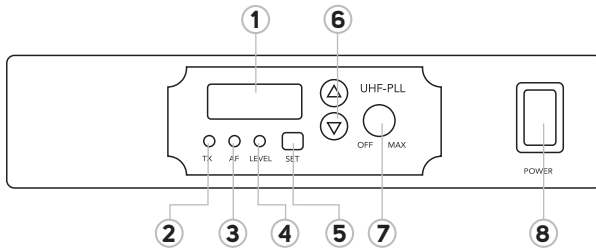

- 1 LCD Display: Ch. # or Freq. Readout
- 2 RF Transmission Indicator (GREEN)
- 3 Audio Signal Present Indicator (YELLOW)
- 4 Flash-Audio Level Being Send (RED)
- 5 Channel "Set" Selector
- 6 Channel "Up/Down" Selector
- 7 Receiver Module: "on/off" and Master Gain
- 8 Titan Neo main Power Switch

1. On the AirLink unit turn the power switch/volume level control clockwise to turn the transmitter on.
2. The LCD screen will display "ON" then revert to the factory default channel (or the channel last selected).
3. To select a channel press the "SET" button until screen flashes. Using the UP/DOWN frequency adjustment buttons you can select the desired channel. Press "SET" again to lock-in channel.
4. On the slave unit turn the wireless receiver module on. Press "SET" and use the UP/DOWN frequency adjustment buttons to set the unit to the same channel as the master unit. Press the frequency set button again to lock in your channel selection.
5. When transmitting audio from the master to slave unit the TX indicator will light green. The AF indicator displays audio level (flashing yellow) when user is speaking into the microphone or music is playing. Excessive audio level is indicated by a (flashing red) light .

Titan Neo COMPONENTS & OPERATION

Companion Speaker

The PA-810 is an AC or battery powered Companion System with a 96 Channel Wireless Receiver for a wireless connection from a Titan Neo Sound System with the TX-800 Wireless Transmitter installed.

The PA-810 can also be utilized as a self contained battery powered PA system with the use of a hardwired handheld microphone (UM-66), or wireless microphone (UT-96HH or UT-96BP).

With the addition of the DD-800 Digital Delay Module, the system becomes PA-815.

DD-800 Digital Delay Module

The Digital Delay Module DD-800 is installed in the companion speaker and is interfaced with DR-800 wireless receiver module. The output of the receiver is passed through the delay module in route to the power amplifier. The purpose of the delay module is to store the signal momentarily and then pass it through to the amplifier input. The delay time can be varied from 20–500 milliseconds thus synchronizing the sound output with the master unit on stage.

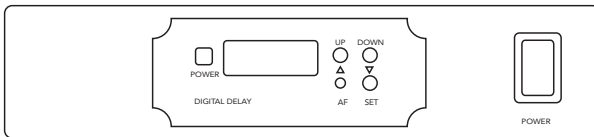

Note

Display times are available in 1.9 ms. increments.

Time Delay Calculation

The true measurement of sound travel is 1125 feet per second. Thus sound travels at the rate of 1.125 feet per millisecond (ms). So the general rule is to round up to 1 foot per ms.

So to calculate the sound delay time from the main sound source to the distant speaker is to pace the distance in feet. Then dial the foot count into the digital delay module in milliseconds (ms). Example, if you were to pace off 150 feet, you would dial the digital delay to 150 ms. Now this approximate setting could be fine tuned by ear for a more exact setting.

To Set The Time Delay

Depress the power switch. The LCD screen will display the last saved delay time. To change the delay time select the "SET" button. Using the UP/DOWN time delay adjustment buttons, set the delay to the desired time in milliseconds. Press the "SET" button to lock in your delay time. □

RECEIVER**Titan Neo UR-96BP Body-Pack Receiver Description**

The Body-Pack Receiver is the component that receives the voice from the Titan Neo transmitter. The audio is transmitted via an RF signal on a selected RF frequency. An external earphone is plugged into the Body-Pack Receiver which picks up the speaker's voice. The receiver is usually worn on the waist utilizing the wire belt clip, however; it can be placed in your pocket if it is more convenient. Line level output can be sent to any device with line level input. Send signal to remote powered speakers, green room, delay speakers, etc. The Body-Pack is battery powered and requires two "AA" size batteries.

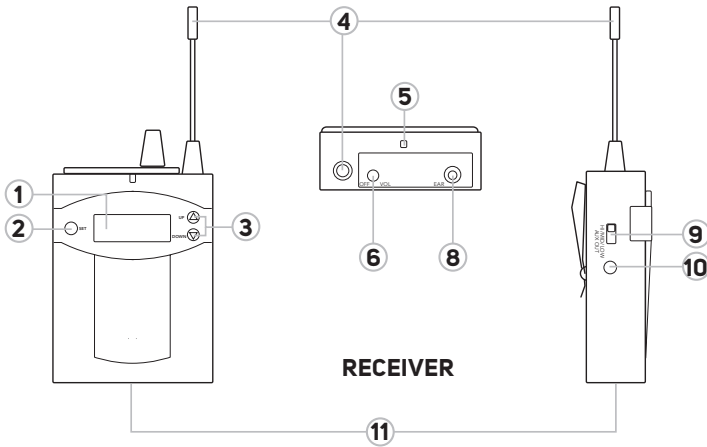

- | | |
|----------------------------------|--|
| 1 LCD Display | 8 Earphone Output Jack (3.5mm) |
| 2 Frequency SET Button | 9 Output Sensitivity Selection Switch (HI, MID, LOW) |
| 3 UP/DOWN Ch. Select Buttons | 10 AUX output Jack (3.5mm) |
| 4 Receiving Antenna | 11 Charging Terminal |
| 5 Power "On" LED Indicator (Red) | |
| 6 Power "ON/OFF", Volume Control | |

- AUX line level output will feed remote powered speakers.

TRANSMITTER

Titan Neo UT-96BP Body-Pack Transmitter Description

The Body-Pack Transmitter is the component that transmits the voice to the Titan Neo receiver. The audio is transmitted via an RF signal on a selected RF frequency. An external microphone is plugged into the Body-Pack Transmitter which picks up the speaker's voice. The microphone can be either a Lapel, or a Headset with a boom microphone. The transmitter is usually worn on the waist utilizing the wire belt clip, however; it can be placed in your pocket if it is more convenient. The Body-Pack is battery powered and requires two "AA" size batteries.

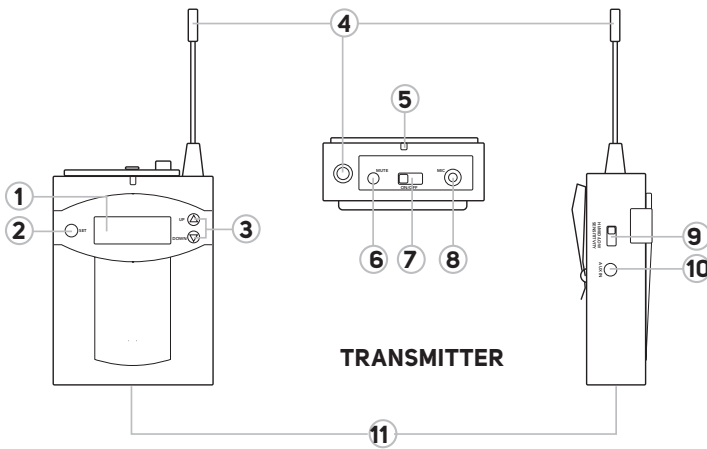

- | | |
|----------------------------------|---|
| 1 LCD Display | 7 Power "ON/OFF" Switch |
| 2 Frequency SET Button | 8 MIC Input Jack (3.5mm) |
| 3 UP/DOWN Ch. Select Buttons | 9 Microphone Input Sensitivity Selection Switch (L,M,H) |
| 4 Transmitting Antenna | 10 AUX Input Jack (3.5mm) |
| 5 Power "On" LED Indicator (Red) | 11 Charging Terminal |
| 6 Microphone Mute Button | |

- Line level sources can be transmitted from the body-pack transmitter to the Titan Neo via the "AUX" input. Also attach the output of a metronome, cell phone, MP3 player or mix console output to the "AUX" input of the body-pack transmitter.
- The body-pack transmitter can transmit to a body-pack receiver, a Titan Neo or DR-801 stand alone receiver.

TRANSMITTER/MICROPHONES

UT-96BP Body-Pack Transmitter Operation

1. Ensure microphone is switched off before inserting batteries.
2. Remove battery compartment cover.
3. Insert two "AA" batteries, observing polarity (alkaline or rechargeable NiMH).
4. Plug in microphone: Lapel or Headset w/boom.
5. Push power switch to "ON". Top power LED will illuminate "Red"
6. "On" will be displayed in the LCD screen.
7. LCD window will display: Battery condition and CH #
8. A selection switch on the side of the body-pack provides three levels of microphone sensitivity (HI/MID/LOW)
 - High: Most sensitive position for weak voice or distant microphone to mouth.
 - Mid: When the microphone used is further away from mouth, such as: a lapel microphone is clipped on clothing away from mouth
 - Low: When microphone is used close to mouth, such as; a headset with a boom microphone or with a very strong vocal performer.
9. MUTE Button: Mutes microphone "off" while retaining transmission and RF Connection
10. Internal Microphone:
 - Locate two small hole on front of transmitter
 - Hold transmitter in front of mouth and speak into it.
11. LCD screen displays the transmission channel number and battery condition
12. To display channel frequency: Press and hold UP or DOWN button.



Danger

**DO NOT ATTEMPT TO
CHARGE ALKALINE
BATTERIES**

FCC Regulation

RF transmission equipment must comply with FCC regulations. All TeachLogic transmission devices comply with Part 15 of the FCC rules and operate in the UHF band in the 640–664 MHz frequency range. Power output is limited to less than 50 milliwatts to prevent any interference with any other RF operated equipment.

TRANSMITTER/MICROPHONES**UT-96BP Body-Pack Transmitter Operation**

13. To change channel selection
 - Press and hold frequency SET button for 2 seconds
 - LCD panel will commence flashing (indicating programming mode)
 - Press UP or DOWN arrow to select channel desired
 - Press SET button to lock in channel selected
14. The battery status is displayed on the left edge of the LCD screen.
15. • When battery nears depletion: Icon will flash 3 times
 - Transmitter will automatically turn "off" to prevent damage
16. To turn microphone "Off"; push power switch to "OFF".

LM-835 Lapel Microphone

The Lapel Microphone (LM-835) is a small capsule microphone with a spring clip for securing it on to a clothing edge. The lapel microphone renders excellent vocal reproduction. The lapel microphone is less obtrusive to the user and least visible.

However, due to the greater distance from mouth to microphone it will require additional gain. As a result it is more prone to feedback. So adjustment of volume is more critical, especially near or under a speaker.

HBM-935 Headband Microphone

The Headband Microphone (HBM-935) is worn around the head with a unidirectional microphone located on the end of a flexible boom. This is the best performing microphone due to its unidirectional mic element and its always close proximity to the mouth. The microphone also renders maximum gain and is least prone to feedback.



Titan Neo

TRANSMITTER/MICROPHONES

UT-96HH Transmitter Microphone Operation

1. Be sure the microphone is switched off before inserting batteries.
2. Remove lower identity cap.
3. Remove lower battery compartment door.
4. Insert two (2) AA batteries (use only alkaline or fully charged NiMH batteries).

Caution: Be sure to observe correct polarity

5. Replace lower battery compartment door.
6. Locate power switch at base of microphone (small gray button)
7. Press upward and hold the power switch for 2-3 seconds.
8. Power LED will illuminate "Red" and "On" will be displayed in the LCD screen.
9. LCD window will also display: Battery condition and CH #
10. A microphone sensitivity selection switch provides three modes of microphone sensitivity (HIGH, LOW, MUTE).
 - MUTE: Mutes microphone "off" while retaining transmission and RF connection.
 - LOW: Use when microphone is held close to mouth or strong vocal input.
 - HIGH: Use when additional sensitivity is required for softer voice.
11. LCD screen displays the channel number selected for the microphone. To display channel frequency: Press and hold the UP or DOWN select button.
12. To change channel selection
 - Press and hold frequency SET button for 2 seconds. LCD panel will commence flashing (indicating programming mode)
 - Press UP or DOWN arrow to select channel desired
 - Press SET button to lock in channel selected



Danger

**DO NOT ATTEMPT TO
CHARGE ALKALINE
BATTERIES**

FCC Regulation

RF transmission equipment must comply with FCC regulations. All TeachLogic transmission devices comply with Part 15 of the FCC rules and operate in the UHF band in the 640-664 MHz frequency range. Power output is limited to less than 50 milliwatts to prevent any interference with any other RF operated equipment.

TRANSMITTER/MICROPHONES

UT-96HH Transmitter Microphone Operation

13. The battery status is displayed on the left of the LCD screen.
 - When battery nears depletion: Icon will flash 3 times.
 - Microphone will automatically turn "off" to prevent damage.
14. To turn microphone "off", press and hold the power switch until the LCD screen displays "OFF".

UT-96HH Transmitter Microphone Description

The handheld microphone/transmitter is equipped with a dynamic microphone element for enhanced clarity and extended dynamic range. Its low handling noise and built-in windscreen makes it well suited for close-up handheld use. It can be powered by either Alkaline or rechargeable NiMH batteries. The rechargeable batteries can be recharged either in the drop-in charger or with the plug-in charger.

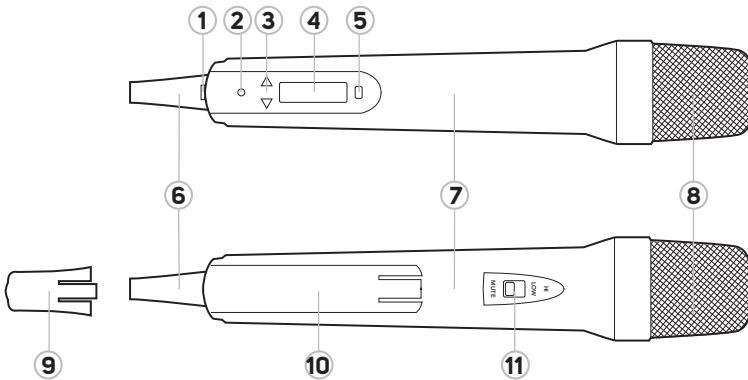

- | | |
|--|--|
| <ol style="list-style-type: none"> 1 Power "on/off" Switch 2 LED Power "on" Indicator 3 Up/Down Frequency Select 4 LCD Readout 5 Frequency Set Button 6 Charging Port Connection | <ol style="list-style-type: none"> 7 Soft Comfort, Non-Slip Body 8 Protective Screen Head 9 Color Identity End Cap 10 Battery Compitany 11 Microphone Sensitivity:
HI/LOW/MUTE Select |
|--|--|

Titan Neo

BATTERY CHARGERS

BRC-10 Plug-In Charger

The BRC-10 charger is designed to charge the UT-96HH Handheld Transmitter/Microphone.

Operating Instructions

- Use "AA" rechargeable NiMH batteries only
- Plug adapter into 110v AC outlet.
- Remove color identification cap.
- Plug cable into jack at the base (bottom end) of transmitter
- Turn Handheld Transmitter "On" to observe battery icon
- During charging, the battery icon will cycle through the charge "block"
- When fully charged, battery icon will display all "blocks" filled
- Charging time; typically 10–12 hours
- Turn Handheld Transmitter "Off" and reinstall color identification cap.



BRC-75 Drop-In Charging Dock

The BRC-75 charger is designed to charge one or two UT-96BP Body-Pack Transmitters.

Operating Instructions

- Use "AA" rechargeable NiMH batteries only in microphones
- Plug power adapter in 110v AC outlet
- Plug cable into base of charger
- Insert one or two body-pack transmitters into charger
- "on" indicator LED lights "Amber" when charging
- "ok" indicator LED lights "Green" when fully charged
- Charging time; typically 10–12 hours



BRC-70 Drop-In Charging Dock

The BRC-70 charger is designed to charge the UT-96HH and/or UT-96BP Body-Pack Transmitter.

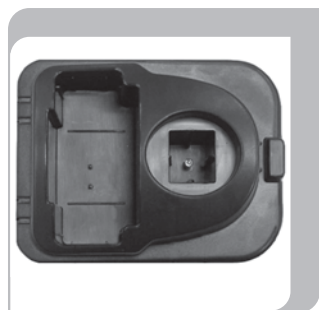

Operating Instructions

- Use "AA" rechargeable NiMH batteries only in microphones
- Plug power adapter in 110v AC outlet.
- Plug cable into base of charger
- Charging Handheld Microphone/Transmitter
 - Remove color identification cap from Hand held microphone, store on cap holder
 - Insert Handheld microphone into small square receptacle
 - Push down firmly in place
- Charging Handheld Indicators (Handheld symbol)
 - "on" indicator LED lights "Amber" when charging
 - "ok" indicator LED lights "Green" when fully charged
- Charging Body-Pack Transmitter
 - Insert Body-Pack into Front/Large receptacle
 - Push down firmly in place
 - Observe front with LCD facing forward (toward you)
- Charging Body-Pack Indicators (Body-Pack symbol)
 - "on" indicator LED lights "Amber" when charging
 - "ok" indicator LED lights "Green" when fully charged
- Charging time; typically 10–12 hours.
- During normal charging the battery icon will cycle through the charge "block" icons
- Remove transmitters when charging is complete
- Reinstall color identification cap on handheld
- Turn transmitter "On", verify battery icon in LCD window shows all blocks filled



TROUBLESHOOTING

UT-96HH Transmitter Microphone

Problem	Solution
Power LED does not illuminate after pressing power switch	<ul style="list-style-type: none">• Check batteries are charged and inserted correctly. When pressing power switch ensure you hold it down for 2–3 seconds•
LCD panel displays garbled information	<ul style="list-style-type: none">• Remove the batteries from the transmitter and re-insert them•
No sound output	<ul style="list-style-type: none">• Confirm frequency of transmitter is the same as the portable PA receiver• Check volume level of both transmitter and portable PA receiver in range of the receiver• Check for sources of interference, large metal objects etc within range of the microphone•
Interference and Signal disturbance	<ul style="list-style-type: none">• Make sure there are no other wireless systems operating on the same frequency in the same area. This includes Microphones, Televisions, Radio Stations, etc.• When operating two transmitters in the same area, ensure frequencies selected are several channels apart. This helps to reduce crosstalk between transmitters.• Also note that other wireless devices can cause interference, ensure you adjust your frequency around these devices where possible.• Try setting the transmitter and receiver to a new channel.

UT-96BP Body-Pack Transmitter Microphone

Problem	Solution
Power LED does not illuminate after switching on	<ul style="list-style-type: none"> • Check batteries are charged and inserted correctly.
LCD panel displays garbled information	<ul style="list-style-type: none"> • Check frequency of transmitter is the same as the portable PA receiver • Check mute button is not activated • Ensure body-pack is within range of the receiver • Check for sources of interference, large metal objects etc within range of the body-pack
Signal disturbance	<ul style="list-style-type: none"> • When operating two transmitters in the same area, ensure frequencies selected are several channels apart. This helps to reduce crosstalk between transmitters. Also note that other wireless devices can cause interference, ensure you adjust your frequency around these devices where possible.

ERR Message

The ERR message may show up on the units ALS-960, DR-702, DR-702D, DR-800, TX-800 and UT-96BP or UT-96HH. In brief, any wireless-based devices that carry a LCD panel might have this potential problem. While the possibility of a glitch is unlikely, it is a possible.

Contact

If you should encounter some unresolved issue, please contact TeachLogic customer service department for further assistance.

☎ 1-800-588-0018

✉ sales@teachlogic.com

📠 1-760-631-1283

🌐 www.teachlogic.com

TROUBLESHOOTING

Sorting out LCD ERR message

The ERR message may show up on the units UT-96HH, UT-96BP, DR-800 and TX-800. In brief, any wireless based devices that carry a LCD panel might have this potential problem. The feasibility of such kind of rick shall be quite few, but it might occur. Following I will give you a instructions to kill this problem. LCD panel works "normally" when shown as below...



"On" shown on the LCD panel when unit was switched on.



In 1–2 seconds, the LCD panel will show channel number that was used last time on the LCD panel.



Generally, there are two possibilities that bring "Error" message to the devices, software or hardware problem. Following instructions will lead you to sort out problems caused by software.

1. RESET built in software by pressing and holding "SET" + "UP" + "DOWN" then Switch unit on.
2. How to know if the RESET is done successfully? "On" message will be shown on the LCD panel and it will stay on "On" message—it won't display the channel last used.
3. When you've successfully cleared the "ERR" message, switch the unit off, then on. Now use the transmitter normally.

BT-800 Wireless Bluetooth Receiver

Unexpected Bluetooth disconnects or intermittent connectivity

- Check that you are in range of the Bluetooth accessory with which you are trying to connect. Most Bluetooth accessories have a range of approximately 30 feet.
- On your device, tap Settings > Bluetooth and find your device in the list. If your device says Not Connected, tap the name of your accessory to attempt to connect it.
- Tap Settings > Bluetooth and turn Bluetooth off and then on again.
- Make sure that your Bluetooth accessory is turned on and fully charged or connected to power.

Source of Interference

- Microwave ovens: Using your microwave oven near your computer, Bluetooth device, or Wi-Fi base station may cause interference. Bluetooth operates at 2.402 - 2.480 GHz
- 2.4 GHz or 5 GHz phones: A cordless telephone that operates in 2.4 GHz or 5 GHz bandwidth.
- Any other wireless devices that operate in the 2.4GHz or 5GHz bandwidth (Microwaves, Cameras, baby monitors, neighboring wireless devices, etc.

Environment Barriers

- If possible, avoid wireless barriers, or change the placement of the Wi-Fi or Bluetooth devices for a clearer signal path. The device's location within building and construction material used can affect Wi-Fi and Bluetooth. Listed below are common types of barrier material and their potential for interference.

Potential

- Low
- Medium
- High
- Very High

Material

- Wood, Synthetic materials, Glass
- Water, Brick, Marble
- Plaster, Concrete, Bulletproof glass
- Metal

TROUBLESHOOTING

Channel Frequency Allocation

640–664 MHz LCD

CHANNEL	FREQ	CHANNEL	FREQ	CHANNEL	FREQ
CH 1	640.1	CH 17	640.9	CH 33	640.4
CH 2	641.6	CH 18	642.4	CH 34	641.9
CH 3	643.1	CH 19	643.8	CH 35	643.3
CH 4	644.5	CH 20	645.3	CH 36	644.8
CH 5	646.1	CH 21	646.9	CH 37	646.4
CH 6	647.6	CH 22	648.4	CH 38	647.9
CH 7	649.1	CH 23	649.8	CH 39	649.3
CH 8	650.5	CH 24	651.3	CH 40	650.8
CH 9	651.7	CH 25	652.6	CH 41	652.1
CH 10	653.3	CH 26	654.1	CH 42	653.6
CH 11	655.2	CH 27	656.0	CH 43	655.5
CH 12	656.7	CH 28	657.5	CH 44	657.0
CH 13	658.2	CH 29	658.9	CH 45	658.4
CH 14	659.6	CH 30	660.4	CH 46	659.9
CH 15	661.2	CH 31	662.0	CH 47	661.5
CH 16	662.7	CH 32	663.4	CH 48	662.9

UHF TV Frequencies

TV Channel	MHz
42	638–644
43	644–650
44	650–656
45	656–662
46	662–668

TROUBLESHOOTING

CHANNEL	FREQ	CHANNEL	FREQ	CHANNEL	FREQ
CH 49	641.1	CH 65	640.6	CH 81	641.4
CH 50	642.6	CH 66	642.1	CH 82	642.9
CH 51	644.0	CH 67	643.5	CH 83	644.3
CH 52	645.5	CH 68	645.0	CH 84	645.8
CH 53	647.1	CH 69	646.6	CH 85	647.4
CH 54	648.6	CH 70	648.1	CH 86	648.9
CH 55	650.0	CH 71	649.5	CH 87	650.3
CH 56	651.5	CH 72	651.0	CH 88	651.9
CH 57	652.8	CH 73	652.3	CH 89	653.1
CH 58	654.3	CH 74	653.8	CH 90	654.6
CH 59	656.2	CH 75	655.7	CH 91	656.5
CH 60	657.7	CH 76	657.2	CH 92	658.0
CH 61	659.1	CH 77	658.6	CH 93	659.4
CH 62	660.6	CH 78	660.1	CH 94	660.9
CH 63	662.2	CH 79	661.7	CH 95	662.5
CH 64	663.6	CH 80	663.1	CH 96	663.9

TROUBLESHOOTING

Channel Selection in a Given Area and Simultaneous Use of Multiple Channels.

Transmission by wireless microphones and low power audio transmitters may encounter various interference problems. Interference may be caused by local area TV or commercial broadcast institutions.

In addition, interference can be due to wireless receivers and transmitters used simultaneously in close proximity to each other. Their fundamental or harmonic frequencies can conflict with each other and cause interference problems; noises, static, hiss, dropouts, squealing or totally inoperative.

The following clusters of channels have been designated that are compatible to operate with each other simultaneously.

Clusters of Compatible Frequencies when using Four (4) channels at the same time

- (1) 19 20 35 36 (2) 10 57 58 59 (3) 19 34 36 39
(4) 20 35 39 69 (5) 57 75 77 90 (6) 11 44 45 57
(7) 07 53 84 87

Clusters of Compatible Frequencies when using Eight (8) channels at the same time

- (1) 06 39 42 45 55 70 89 90
(2) 17 18 20 33 34 36 37 89
(3) 01 02 06 37 49 50 70 84
(4) 02 49 50 52 68 69 71 86
(5) 34 40 52 57 68 69 81 82

Clusters of Compatible Frequencies when using Twelve (12) channels at the same time

- (1) 20 21 49 50 58 65 66 71 75 85 85 87
(2) 02 17 21 22 25 26 41 42 67 82 85 86

Note

When interference problem is encountered, verify that the microphones are operating on frequencies in the same cluster.

If TV or other transmission is interfering, change all the wireless components to another cluster.

Portable PA System

Output Power	50 W RMS, 80 W Max
Sensitivity	91dB, 1W @ 1M
Maximum SPL	95 dB
Frequency Response	20 Hz - 20 kHz (audio)
Speaker	8" LF Neodymium Woofer 1" HF Horn
Signal to noise Ratio	>70dB
Audio Input	XLR-TRS Balanced Mic Line Level, Dual RCA
Audio Output	Line Level, Dual RCA
Controls	Master Volume, Treble, Bass Mic Vol.
Rechargeable Battery Type	Two 12 VDC / 4.1 AH, NiMH
Operating Life	About 6–8 hours
Charging Time	About 8–10 hours
Power Supply	100–240 V AC Input European Approval
Dimensions	11 ¾" W x 18 ½" H x 9" D
Weight	21 lbs.

General Wireless Systems

Operating Frequencies	640–664MHz
Selectable Channels	96 Pre-Programmed
Maximum Deviation	80 kHz, with Level Limiting
Dynamic Range	110dB
THD	> 0.5%
Pre/De-emphasis	50 µs
Sensitivity	4 µV@ 30 dB SINAD
Squelch	Tone Key and Noise Lock
Frequency Response	50 kHz, -17 kHz, ± 3dB
Operating Power	30 mW
Operating Range	In Excess of 500 ft. with Half-Wave Antenna
Power Requirements	12–15 VDC, 1 Amp

SPECIFICATIONS

UT-96HH Handheld Transmitter Microphone

Mic Capsule	Dynamic
RF Output	10mW
Spurious Emission	250mW
AF Controls	Hi/lo/mute switch
Battery	1.2V NiMH rechargeable x 2 or 1.5V Alkaline x 2
Operating Life (fully charged)	11 hrs (NiMH) or 14 hrs (Alkaline)
Dimensions	1.80" x 10.39"
Weight (with batteries)	280g

UT-96BP Body-Pack Transmitter Microphone

Mic Capsule	Dynamic
RF Output	10mW
Spurious Emission	250mW
AF Controls	Hi/lo/mute switch
Battery	1.2V NiMH rechargeable x 2 or 1.5V Alkaline x 2
Operating Life (fully charged)	11 hrs (NiMH) or 14 hrs (Alkaline)
Dimensions	1.80" x 10.39"
Weight (with batteries)	280g

SPECIFICATIONS



DR-800 Wireless Auto-Scan Receiver

Dimensions	3 1/2" W x 1.5" H x 5" D
Weight	4 oz.



DR-850 Dual Wireless Receiver

Dimensions	3 1/2" W x 1.5" H x 5" D
Weight	6 oz.



BT-800 Bluetooth Receiver Module

Dimensions	3 1/2" W x 1.5" H x 5" D
Weight	3 oz.



TX-800 Wireless Transmitter

Dimensions	7 1/2" W x 1 3/16" H x 4" D
Weight	10 oz.



CD-800S Player

Formats	MP3, WMA
Media	CD, USB drive, SD&MMC card
Dimensions	7 1/2" W x 1 3/16" H x 4" D
Weight	2 lbs. 3 oz.



DD-800 Digital Delay

Delay Range	20–500 ms.
Increments	1.9 ms.
Dimensions	7 1/2" W x 1 3/16" H x 4" D
Weight	4 oz.

Titan Neo

ACCESSORIES



ALS-960 AirLink Wireless Transmitter and DR-702D or DR-801 Receiver

The ALS-960 AirLink transmitter and DR-702 or DR-801 receiver work perfectly with our Titan Neo portable powered sound system for longer distance.

UM-66 handheld microphone w/ 15' cable

Handheld dynamic microphone for simultaneous use with the wireless microphones. The 1/4" phone plug plugs directly into the mic in jack. The wired mic in has its own independent volume control. So you can truly have a three microphone system. The microphone has very low handling noise, a built-in breath filter and wide dynamic range.



CC-750 Carrying Bag for Titan Neo

Carrying case holds PA-800 speaker with opening for handle & side storage pocket for transmitters, cables, etc.

SS-750 Heavy Duty Speaker Stand

Heavy duty speaker stand for Titan Neo sound system. Folding tripod adjustable height from 30" to 60", 1 3/8" dia.



UR-96BP Body-Pack Receiver

Wireless Body-Pack receiver, 96 channel with NiMH rechargeable batteries and single ear speaker (ES100) This unit is ideal for a wireless connection to a powered speaker at a remote location.

WARRANTY

Three Year Limited Warranty

TeachLogic RF products are guaranteed to be free of defects in workmanship or material for a period of three (3) years from date of original purchase, subject to the following conditions:

1. Warranty excludes defects caused by normal use and wear, any abuse, or failure to use the product in accordance per instructions.
2. Warranty is void if damage occurred because of misuse, or attempted repair or modification by unauthorized personnel.
3. Warranty on cables, and cable connections are limited to one (1) year.
4. Warranty on batteries is for two (2) years.
5. Warranty on microphones and microphone elements are limited to one (1) year.
6. Warranty does not extend to finish or appearance past ninety (90) days.
7. All warranty service will be provided by TeachLogic or authorized service center
8. Warranty is made to the original purchaser and may not be transferred to another user.
9. Warranty service rendered will be on a repair or replacement basis, whichever TeachLogic deems to be most prudent for customer satisfaction and economic feasibility.

Contact

If you should encounter some unresolved issue, please contact TeachLogic customer service department for further assistance.

 1-800-588-0018

 sales@teachlogic.com

 1-760-631-1283

 www.teachlogic.com

TeachLogic will only accept warranty shipments accompanied by Return Authorization Number previously assigned by TeachLogic personnel. Advance warranty replacements will be made per the discretion of TeachLogic personnel.

TeachLogic will pay return shipping cost on all warranty repairs or replacements.

Feed your program mix to the AirLink Transmitter. It will wirelessly transmit your program to multiple receiver locations, even through several floors

Wireless Line Level Router

The AirLink router allows you to take a line level signal from your mixing console or playback device (MP3-iPod), plug it directly into the AirLink transmitter and then broadcast that audio to multiple distant Titan Neo portable systems. The AirLink system operates on the 640-664 MHz band and has 96 available channels to select from. You can also transmit to multiple DR-702D AirLink wireless receiver. Perfect for getting sound across a **football field, into overflow areas at a house of worship or backstage areas during a concert.** 40 milliwatts output.



Send the output of your mix

ALS-960 Transmitter

PA-2280 Periodic Log Yagi Directional Antenna



“Paddle” antennae are excellent for doubling the transmission or receiving distance of AirLink routers. These directional antennas on a ALS-960 transmitter can send a signal nearly 1000 feet to an AirLink diversity receiver. Adding paddles to the receiver can increase that distance to almost 2000 ft.

OPTIONAL AirLink Wireless

Wireless capabilities for a multitude of applications

Use the AirLink on the **athletic field, playground control, golf courses, multi purpose room, cheerleaders, out door assemblies, pool parties**, you name it. You can add unlimited wireless receivers and “broadcast” the entire mix signal from the ALS-960 Transmitter to as many wireless systems as needed.



THINK BEYOND

think
WIRELESS



DR-702-D Diversity
Receiver with Delay

Titan Neo Portable PA System

Titan *neo*

Stand alone diversity receiver with up to 500 msec of delay. Excellent for providing delay signal to back of auditorium or large outdoor events.

UR-96BP Body-Pack Receiver





The Body-Pack Receiver is great way to turn any powered speaker into wireless system. The UR-96BP matches perfectly with our AirLink transmitter and allows you to broadcast to an unlimited number of receiver units. The UR-96BP is powered by 2 AA batteries for all day use, and its metal case provides the utmost in durability. The wide bandwidth of this receiver gives you very high quality audio in a very small size.



TeachLogic

FOR SOUND LEARNING 

TeachLogic, Inc.
1688 Ord Way
Oceanside, CA 92056

 1-800-588-0018
 sales@teachlogic.com
 1-760-631-1283
 www.teachlogic.com

Touchboards

205 Westwood Ave, Long Branch, NJ 07740
Phone: 866-94 BOARDS (26273) / (732)-222-1511
Fax: (732)-222-7088 | E-mail: sales@touchboards.com

7-28-14