



# Spectrum™ (IMA-840)

## Classroom Audio System Installation Manual



# Welcome

Congratulations on the purchase of your new TeachLogic® classroom audio system. You can be assured that this product fulfills all specifications and was produced to high quality control standards.

TeachLogic incorporates the latest state of the art technology, employs the most advanced manufacturing methodology and uses only premium quality components to assure many years of reliable performance. We appreciate your confidence by your selection of our product. It is TeachLogic's intent to uphold that confidence by providing factory assistance and reseller support. This manual will help you learn to use and gain the maximum benefit of the system.

**We hope you will take the time to review this manual to familiarize yourself with the product operation and features.**

**TeachLogic, LLC**  
Longmont, Colorado USA  
[www.teachlogic.com](http://www.teachlogic.com)

# Safety Instructions

## Read Instructions

All safety and operation instructions should be read before operating this TeachLogic product.

## Retain Instructions

Safety and operating instructions should be kept for future reference.

## Water & Moisture

This product should not be operated near water.

## Heat Environment

Do not subject this product to excessive heat conditions.

## Power Source

This product must be connected to an AC power source per the voltage input specified and marked on the power supply.

Do not insert any power cable not provided by the manufacturer into the product. Long prongs can penetrate inside electrical components or current charging conductors.

## Certifications



TeachLogic systems are manufactured using lead-free processes and are free of materials harmful to the environment. They conform to European RoHS guidelines for consumer products.

## Power Cord Caution

Power cable should be routed clear of foot traffic and supported clear of kinking or abrasion.

## Object Protection

Locate the operating unit so it will not be subjected to falling objects or water entry. Do not drill hole in or screw objects into the product except as specified by manufacturer.

## Internal Service

User should not attempt to service this product. All internal service must be accomplished by a qualified technician.

## Electric Shock

Do not adapt or modify the AC power plug. Do not remove thus lifting the earth ground connection (3<sup>rd</sup> prong) or use power supply without a connector to a 3-prong grounded outlet.

## CAUTION

**Recycle**—Do not dispose rechargeable batteries in trash. It is unlawful to do so in numerous states. **Go Green.** Save our resources and do not contaminate.

Contact: [Earth911.com](http://Earth911.com)  
1-800-CLEANUP



## System info

---

Date of Purchase

---

Model Number

---

Serial Number

### Notes

---

---

---

---

---

---

---

---

## Contact

If you should encounter an unresolved issue, please contact the TeachLogic customer service department for further assistance.

760-631-7800 | [support@teachlogic.com](mailto:support@teachlogic.com) | [teachlogic.com](http://teachlogic.com)

## Limited warranty

For full warranty details refer to [teachlogic.com/warranty](http://teachlogic.com/warranty).

# Contents

System Overview .....	5
System Diagram .....	6
<b>Installation .....</b>	<b>7</b>
<a href="#">Installation Planning .....</a>	<a href="#">7</a>
<a href="#">Connection of Speakers.....</a>	<a href="#">8-9</a>
<a href="#">Installation of Ceiling Sensor .....</a>	<a href="#">10</a>
<b>Integration .....</b>	<b>11</b>
<a href="#">Page Mute/Pass Through Integration .....</a>	<a href="#">11-12</a>
<a href="#">Fire Alarm Input .....</a>	<a href="#">13</a>
<a href="#">RS-232 Feature .....</a>	<a href="#">15</a>
<a href="#">Security Alert Feature .....</a>	<a href="#">15-16</a>
<b>Configuration .....</b>	<b>17</b>
<a href="#">Final Setup.....</a>	<a href="#">17</a>
<a href="#">Power Button Lights   Standby Function .....</a>	<a href="#">18</a>
<a href="#">Troubleshooting .....</a>	<a href="#">19</a>
<a href="#">System Specifications.....</a>	<a href="#">20-21</a>

### Front Panel

1. Power Button/ "TL" Indicator LED
2. Channel A Microphone Volume Control
3. Channel A Connectivity Indicator LED
4. Channel B Microphone Volume Control
5. Channel B Connectivity Indicator LED
6. DVD Input Volume Control
7. Computer Input Volume Control
8. Aux Input Volume Control
9. Video Conference Input Volume Control
10. Video Conference Input Port (3.5 mm) (also suitable for Aux audio source)
11. Video Conference Output Volume Control
12. Video Conference Output Port (3.5 mm) (also suitable for Lesson Capture)

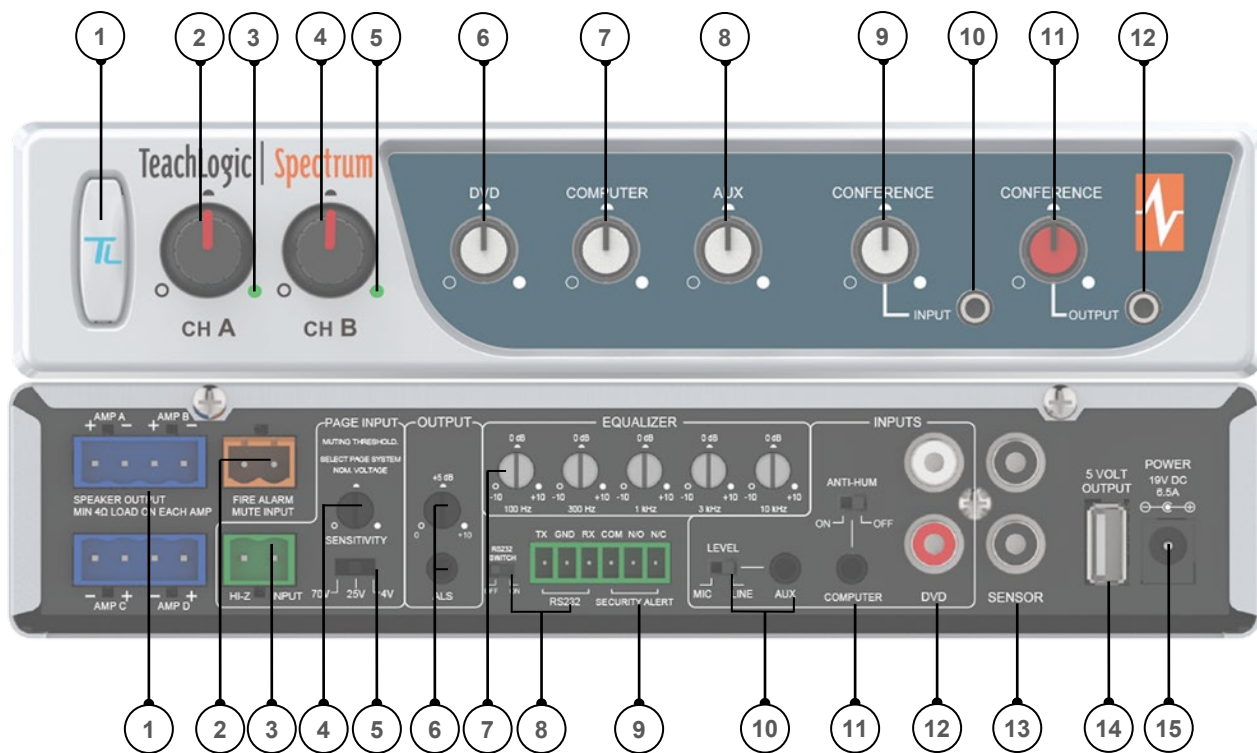

### Back Panel

1. Speaker Output
2. Fire Alarm Mute Input
3. Page Input
4. Page Sensitivity Control
5. Page Input Voltage Selector
6. ALS Output (3.5 mm) & Gain Control
7. Five Band Equalizer Controls
8. RS-232 Input & OFF/ON Switch
9. Security Alert Interface
10. Aux Input Port (3.5 mm) & Aux Mic/Line Input Level Selector
11. Computer Input Port (3.5 mm) / Computer Anti-Hum ON/OFF Switch
12. DVD Input Ports (RCA, 2)
13. Powered IR Ceiling Sensor Inputs (RCA, 2)
14. 5 Volt USB Output for chargers
15. Power Input: 19 VDC, 6.5 A

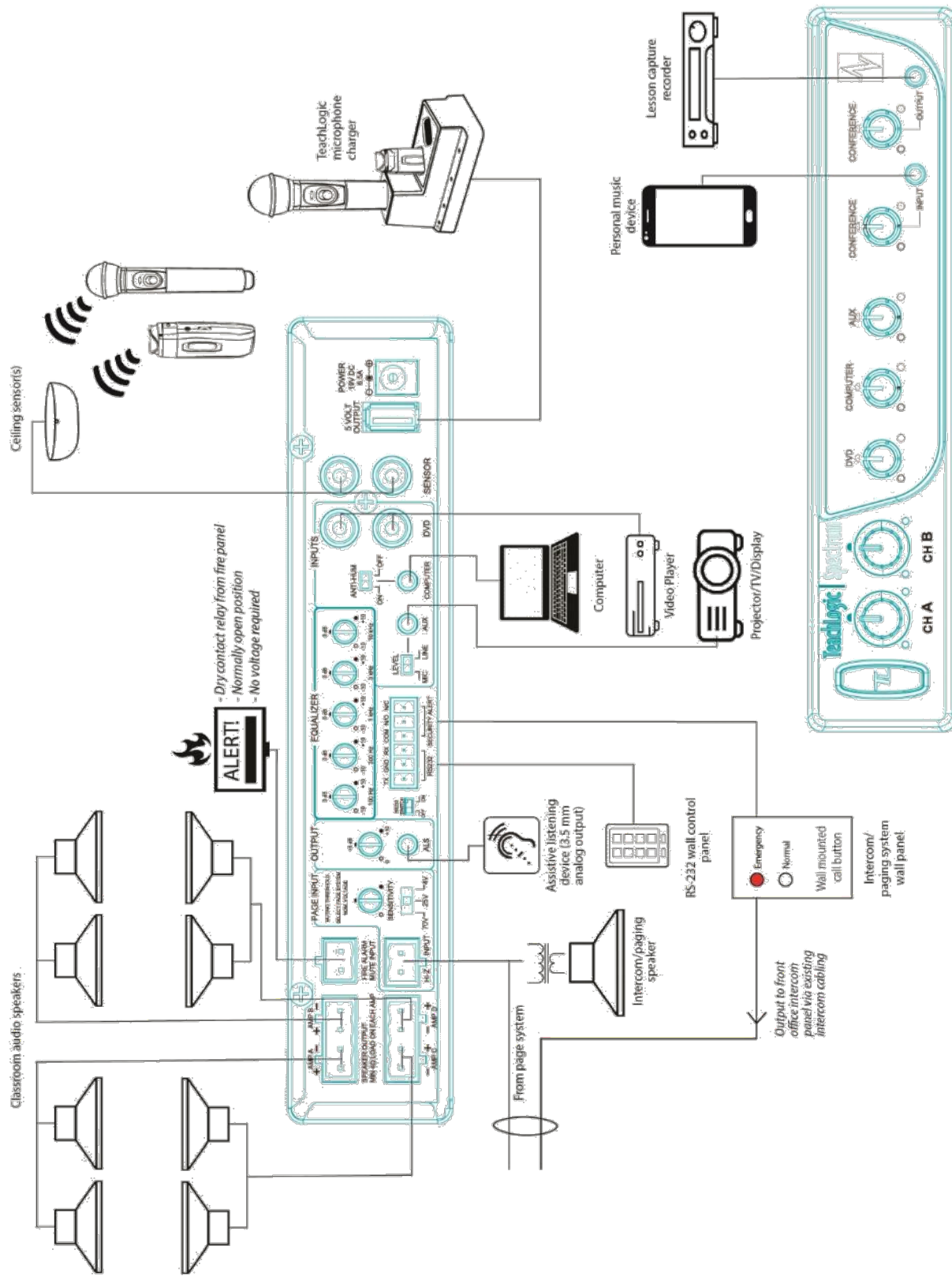

TeachLogic® Spectrum™ (IMA-840) Wiring Diagram

The goal of a classroom audio system is to evenly distribute sound throughout the listening area.

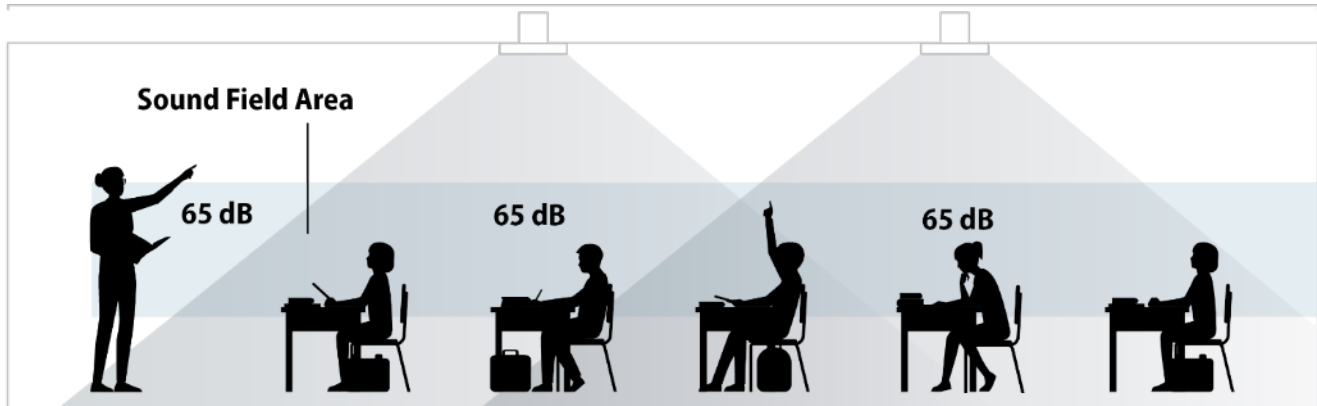

## Component Placement

1. **Amplifier:** Choose location that supports accessibility requirements and wiring constraints for power, speakers, ceiling sensor, and audio devices connecting to the amplifier.
2. **Ceiling Sensor:** Locate in the center of the ceiling; maintain line of sight to teacher locations; keep away from direct sunlight and electrical interference.
3. **Speakers:** The Spectrum™ can power 8 classroom speakers. Mark location for wall mount vs. ceiling mount and confirm wiring run to the amplifier. Ensure speakers evenly cover the listening area.
4. **Integrations/Connections:** Confirm location of other systems you plan to connect to the amplifier such as audio devices, flat screens, projectors, intercom connections, and fire alarm, noting how the wiring needs to run.
5. **Charger:** Confirm microphone charging location for daily use/charging.

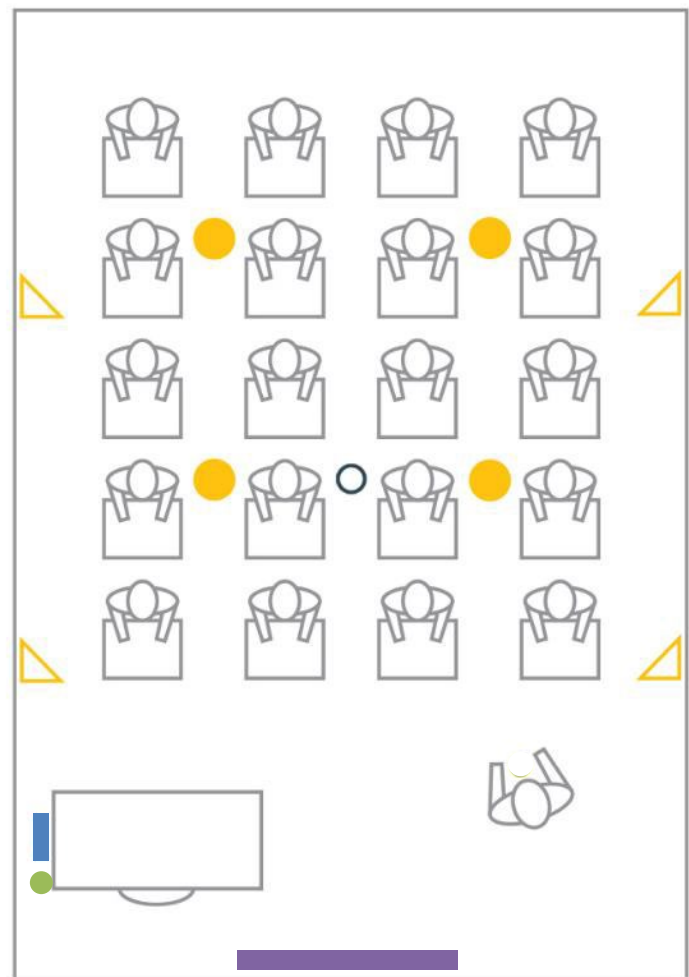



## Speaker Location

Below are examples of room coverage for two and four speaker installations. For more than 4 speakers, space the next row(s) accordingly.

**Ceiling Speakers:** Locate and identify the center most tile in each quadrant.

**Wall Speakers:** First observe the shape of the room: ceiling height, door locations, windows, mounting surface, and seating area. Ordinary installation would be to locate the speakers on each side wall beginning at the front row of listeners, approximately 6–7 feet above the floor.

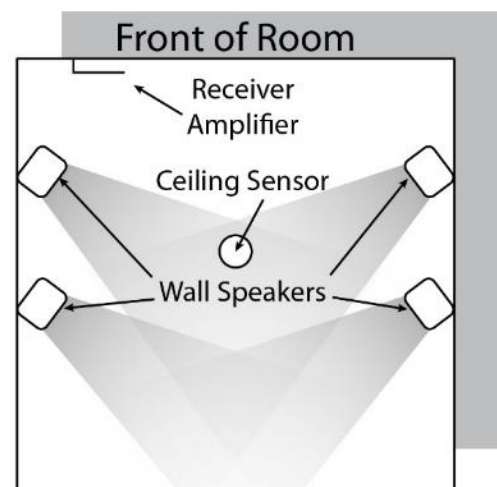
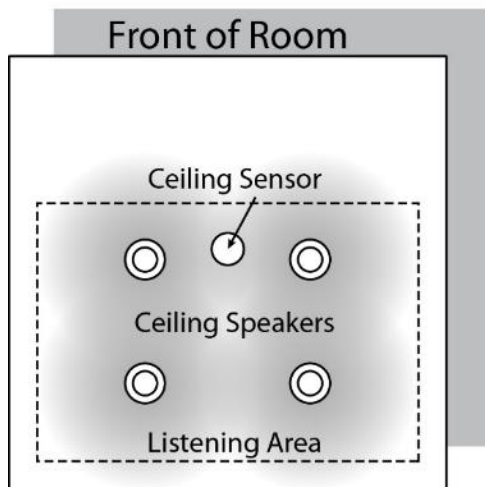
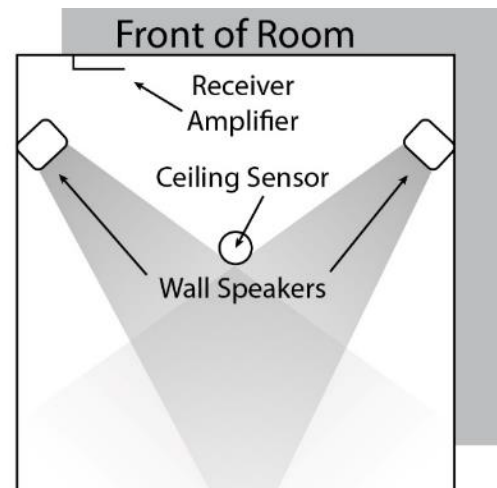
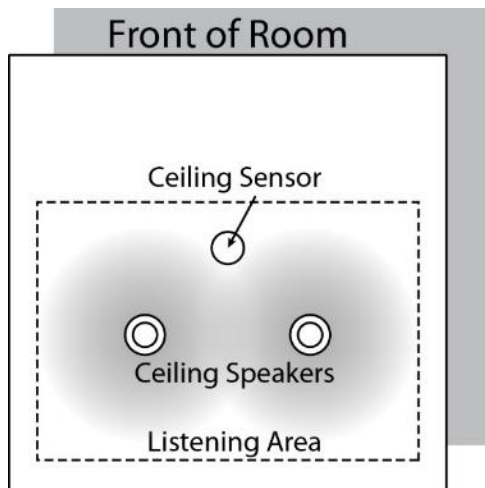

## Connection of speakers

The IMA-840 has four channels of amplified audio, rated for a minimum 4-ohm speaker load (two 8-ohm speakers each, connected in parallel provide 4 ohms impedance).

There are two blue phoenix style speaker connectors on the back panel, each providing two pairs of speaker terminals. The top connector provides connection to two different channels as does the bottom connector.

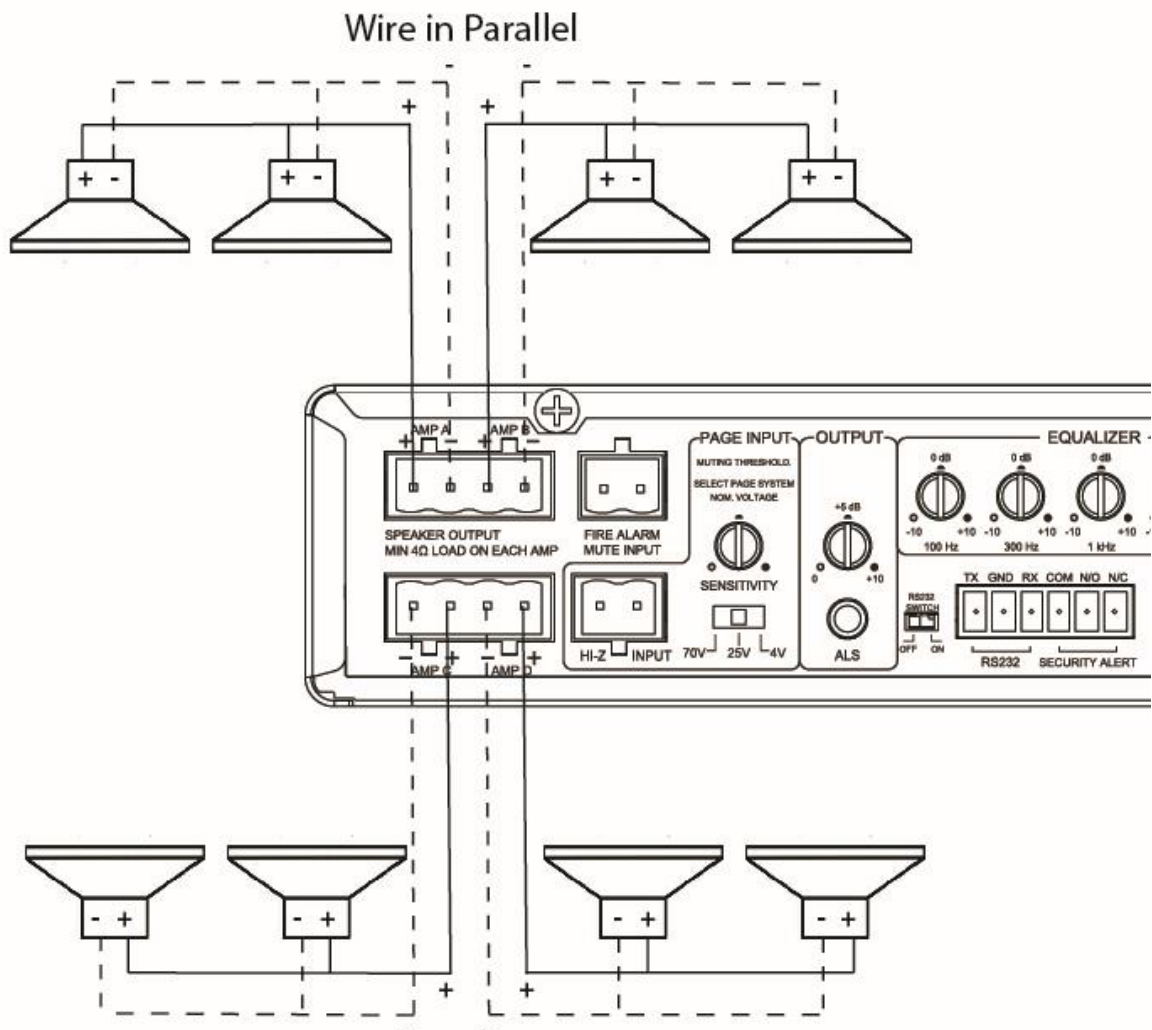

## Installation of Infrared (IR) Ceiling Sensor (ICS-55)

The ideal mounting location is in the center of the room's ceiling. The ideal installation is flush mounted on a white, reflective ceiling like suspended acoustic ceiling tiles. This will ensure 360° coverage and will minimize the transmission distance for more reliable performance.

For additional coverage, or in large rooms, a second IR sensor may be placed on ceiling or a wall and connected to the second sensor input. As many as three sensors may be powered by the amplifier (use a wye adapter for two of them to connect to one input). **The max cable length is 100 ft.**

### Installation 1 – Attach to T-bar rail

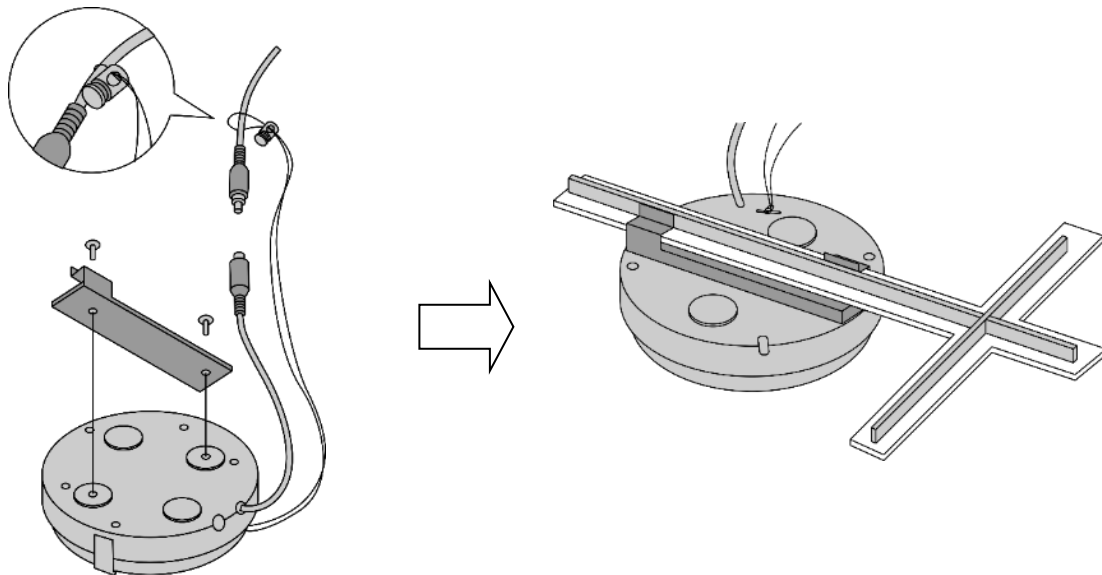

### Installation 2 – Concrete or Drywall Surface

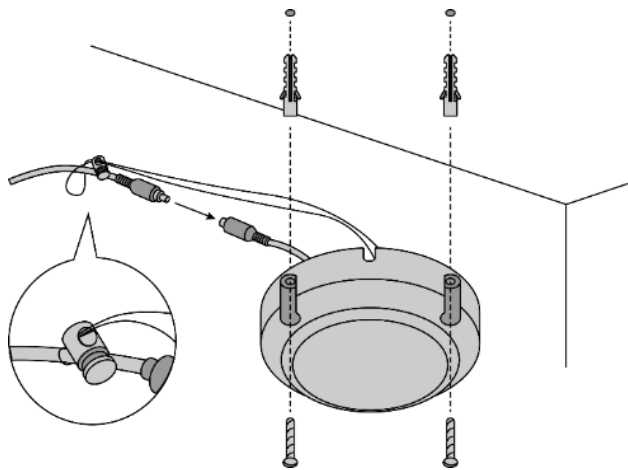

### Installation 3 – Wood Surface

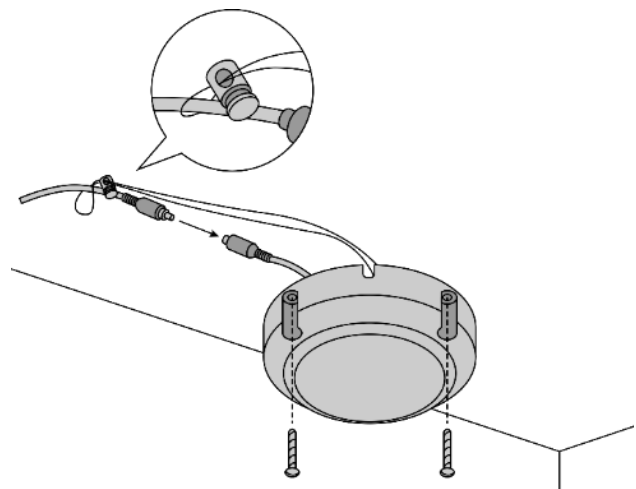

**FINAL STEP:** Route sensor cable to amplifier and plug into one of the amplifier's two sensor inputs. An illuminated green LED will indicate that the sensor is receiving power from the amplifier.

## Page Mute

### System behavior for Page Mute

Page Muting causes the amplifier to silence the microphones and audio sources connected to the amplifier when a page signal is detected on the Page Input terminal. When muted, the only audio allowed to pass through is from the paging system, i.e. Page-Pass-Through Function (PPT).

The amplifier can integrate with constant voltage analog paging systems (70V and 25V) as well as low power VOIP amplifiers (as low as 1/8 watt).

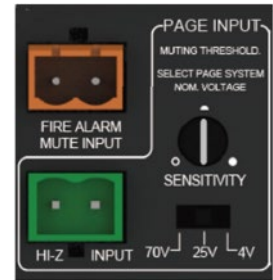

### Connecting the system:

Before connecting, the installer is responsible for determining that the TeachLogic amplifier impedance is compatible with the paging system.

1. Unplug the 2-pin green Phoenix connector.
2. Connect a cable from the paging system driving its speakers to the 2 pin Phoenix connector of the Page input.
3. Reconnect the 2-pin green Phoenix connector.
4. Determine the signal level of the paging system (4V, 25V, or 70V).
5. Set the Page Mute slide switch to the appropriate speaker level setting.
6. With the TeachLogic amplifier turned ON, send a page to test the mute function.
7. Adjust the sensitivity control to ensure the amplifier senses the page signal, noting that some pages with quiet voices will require greater sensitivity settings. The system will maintain its mute until about 11 seconds after the page signal falls below the threshold for sensing. Thereupon, the wireless mics are unmuted, and other audio levels are ramped up smoothly to their prior volume (before mute).

**Table 1.** Impedance of Page Input interface and Sensitivity for Page Mute function

Switch Position	Nominal Impedance /Power Draw	Maximum Sensitivity (minimum threshold for muting)	Minimum Sensitivity
4V	92 $\Omega$ / 0.17 W	51 mV	1.0 V
25V	44 k $\Omega$ / 0.01 W	430 mV	6.5 V
70V	403 k $\Omega$ / 0.01 W	1.2 V	18.3 V

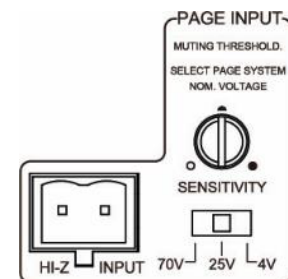

## Page Pass Through

Page-Pass-Through is a feature that passes an audio paging signal through the amplifier and to the connected loudspeakers. This may be switched on or off by a side panel switch. See Table 2.

### IMPORTANT:

The system does not pass-through paging audio signal to the speakers when the amplifier is powered off (or no power is available).

### PPT on ALS output

The amplifier routes the paging input signal by passing it through to the assistive listening system (ALS) output (and Conference Output) so that students using ALS products will hear broadcast paging announcements.

Table 2.

 SWITCHES ON LEFT SIDE OF DEVICE  VISIBLE BEHIND VENTILATION GRILL	SWITCH POSITION	LEFT SWITCH SECURITY ALERT:# OF PULSES	MIDDLE SWITCH PAGING PASS THROUGH TO SPEAKERS	RIGHT SWITCH CONFERENCE ECHO GUARD
	UP	1	OFF	ON
DOWN	4	ON	OFF	

## Fire Alarm Mute Input

The 2-pin orange Phoenix connector labelled Fire Alarm Mute Input provides a connection to mute the TeachLogic amplifier.

### SYSTEM BEHAVIOR

- When interfaced to the fire alarm panel relay contact output, all audio inputs (microphones, DVD, etc.) will MUTE.
- In the event of a fire, this will help to lower the overall decibel levels and help students and staff hear the audible fire alarm tones/ instruction within the classroom.
- Audio resumes at original volume 11 seconds after closure ceases being detected.

### CONNECTION

- This feature requires a contact closure from the Fire Alarm Panel and the TeachLogic terminal is for a normally open connection.
- Fire alarm system connects to a 2-pin Phoenix connector on back of amplifier.
- Refer to fire alarm system manual or manufacture's spec to confirm proper wire connection.

### KEY SPECS

- Dry contact closure
- Normally open position
- No voltage required



## RS-232 Control Feature

The RS-232 control feature allows the user to remotely adjust the volume (or gain) of all the audio sources connected to the amplifier. Such control may be exercised from a separate wall panel controller or other device. The third-party RS-232 device is connected via three wires to the back panel connector shown to the right: TX/Gnd/RX.

This allows the receiver/amplifier to be placed in an area or compartment that is not easily accessed by the user.

Codes that are required for this setup are available on the [teachlogic.com/resources](https://teachlogic.com/resources) page under “Application Notes” or directly at <https://TeachLogic.com/TeachLogic-app-notes-rs-232-control/>.

Audio levels very often need to be adjusted when switching from computer audio to DVD players and other audio sources. Such operations as level UP, DOWN and MUTE are easily accomplished via a typical eight button controller. Shown here is a *Cables To Go* controller.

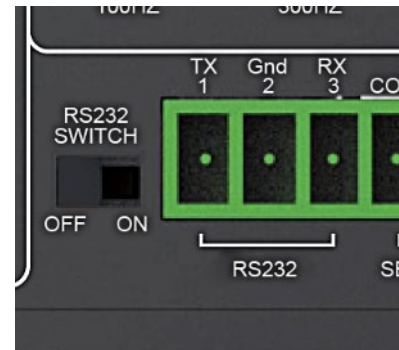

### Connecting the control panel:

1. Connect the control panel wires to the provided 3-pin Phoenix connector.
2. Turn RS232 SWITCH to ON position. This will disable the function of the input volume/gain control knobs on the front of the amplifier.

#### IMPORTANT

When any remote panel is connected, RS-232 switch must be in "ON" position.  
When panel is not connected, RS-232 switch must be in "OFF" position for amplifier controls to function.

## Anti-Hum Feature

The rear panel input port labeled “Computer” has a switchable feature to eliminate or reduce hum sounds often present when computers are connected to external amplifiers. The hum is known as a ground loop hum and may be present if the computer and amplifier have electrical grounding differences. The telltale characteristic is that it is 60 hertz (a somewhat low tone.) Inside the amplifier is a ground isolating balun that may reduce or eliminate the hum when switched ON. If not needed, it is better to leave switched OFF as the sound quality for the connected device will be slightly better in this case.

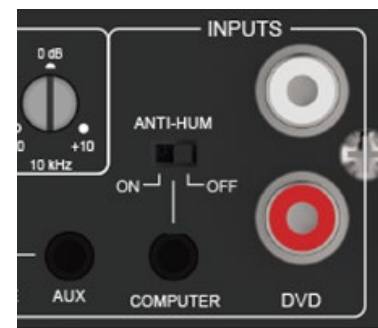

## Security Alert Feature

The Security Alert feature allows a user with a TeachLogic wireless microphone to summon help or indicate to administration personnel of an urgent situation in the room of that user.



### CONNECTION

- Uses wire from paging manufacturer's wall-mounted call button panel to connect to amplifier via 3-pin Phoenix connector: COM | NORMALLY OPEN | NORMALLY CLOSED

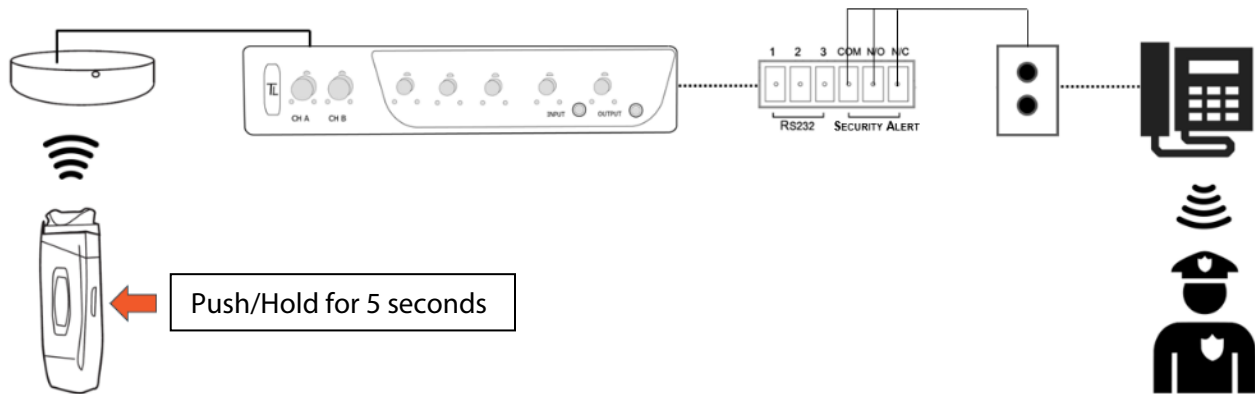

### SYSTEM BEHAVIOR

- When the Sapphire's "Priority" button is pushed/held for 5 seconds, it sends a signal to the ceiling sensor which passes through the amp to the security alert interface (an electric relay).
- The relay contacts opens or close (depending on the normal status) to pass the signal through the paging system as if the paging system's wall-mounted button was being pressed.
- The amplifier functions normally during the alert, e.g. there is no change to audio input/output volume change nor does the system produce any sound

### Setting Security Alert pulses with slide switch

The pulse change can be made with a dedicated switch to select either 1-pulse or 4-pulse mode as required by different security systems. Reference the label on the bottom of the amplifier for the settings.

 SWITCHES ON LEFT SIDE OF DEVICE  VISIBLE BEHIND VENTILATION GRILL	SWITCH POSITION	LEFT SWITCH SECURITY ALERT:# OF PULSES	MIDDLE SWITCH PAGING PASS THROUGH TO SPEAKERS	RIGHT SWITCH CONFERENCE ECHO GUARD
	UP	1	OFF	ON
DOWN	4	ON	OFF	



SLIDE SWITCHES



## Testing the Security Alert function

*To test security alert, you will need an IRT-60 (Sapphire™) microphone.*

1. Turn on an IRT-60 Sapphire microphone by holding the “TL” button until it illuminates.
2. Once the “TL” is illuminated solid blue, locate the “Priority” switch on the side of the microphone.
3. While looking at the amplifier’s power button, press & hold the microphone’s Priority button for 5 seconds after which time the amplifier’s power button will rapidly flash green. There will be an audible clicking sound from the amplifier when flashing.



## Final Setup

Now that the system is installed and connected, turn the system “ON” and test its performance. The testing will be done using an IR (infrared) microphone (Sapphire™ or Handheld) to confirm good connectivity.

### AMPLIFIER

- Connect power supply to amplifier, then plug into outlet.
- Turn the amplifier ON by pushing the power button. The “TL” illuminates solid blue when the amplifier is powered ON.
- Confirm there is power to the IR ceiling sensor: A green LED on edge of sensor should be illuminated that indicates it is receiving power.
- Set all gain/volume dials to mid scale (12 o'clock position)

### IRT-60 (SAPPHIRE) MICROPHONE SETUP

- Confirm "Ch A" volume dial is at mid scale (12 o'clock position)
- Slide gain/volume control switch on Sapphire to "Normal" setting.
- Press and hold power mic button until the LED light illuminates.
- Observe Sapphire power LED. Solid blue indicates power is on and mic is transmitting.
- Observe amplifier Ch A indicator LED. It should be green, indicating a connection between the microphone and ceiling sensor.
- If using two IRT-60 microphones in the same room, one must be changed to channel B to avoid interference. Watch the how-to video on [teachlogic.com/resources](http://teachlogic.com/resources).

#### Note: Next steps should be performed with a second person as the listener

- Stand under or in front of a speaker.
- Hold the microphone with the top at your collarbone and observe the speaker volume in the room by speaking in a natural voice.
- Raise the volume on Ch A until feedback begins, then reduce volume to an acceptable level and until indications of feedback have stopped.
- Walk around the room while talking into microphone to confirm good connectivity and sound levels and lack of feedback under/in front of each speaker.

### IRH-35 HANDHELD MICROPHONE SETUP

- Confirm "Ch B" volume control is set to mid-scale (12 o'clock position)
- Power on microphone using ON/OFF switch.
- Observe LED above mic switch. Solid green indicates power is on and ready to use.
- Observe amplifier Ch B indicator LED. It should be green, indicating a connection between the microphone and IR ceiling sensor.
- Hold the microphone about 3 inches from the mouth, above chin level and perform voice test.
- Raise the volume on “Ch B” until feedback begins, then reduce volume to eliminate all feedback.
- Walk around the room while talking into the microphone to confirm good connectivity and sound under/in front of each speaker without feedback.

**Once complete, charge microphones so they are ready for use.**

## Power Button Operation

The main power button on the amplifier's front panel has multiple indications as shown in the table below.

<b>Red, solid</b>	<b>Off state; power is still supplied to USB port on back panel used to charge microphones</b>
<b>Blue, solid</b>	On
<b>Blue flashing</b>	Page received and audio sources muted
<b>Amber, solid</b>	In Standby (or "Sleep") mode. See below
<b>Red, flashing</b>	Muted by Fire Alarm Mute Input
<b>Purple,</b>	System in Ducked mode with all line inputs lowered in volume to allow microphones to be better heard. The Sapphire mic on Channel A can trigger this "Teacher Priority" mode with a press of its priority button (toggles mode on and off)
<b>Green/Red flashing</b>	Indications of Security Alert pulse mode (see section above)
<b>Green Flashing</b>	Security Alert activated

## System Standby Function

Standby Mode is a feature that reduces power consumption after the amplifier has not been used to amplify audio signal for a period of two hours. After entering the automatic standby mode, the amplifier displays an amber light at power button.

Normal ON mode may be resumed by

1. speaking into a microphone that is on,
2. sending an audio signal into one of the line inputs \*such as a projector or flat panel audio signal), or
3. pressing the power button once.

It may take a few seconds for the normal mode to resume after one of these actions is taken. A page signal can also "wake" the amplifier, but to hear the full first page of a morning, be sure to wake it first with one of the methods above since, or the initial several seconds may be missed if there are no other paging speakers provided to deliver the page audio.

## Troubleshooting

Problem	Solution
<b>System will not power “ON”</b>	<p>Verify AC power; the power button will illuminate Blue when turned ON</p> <p>Check if system has been unplugged; reconnect to power outlet or use another device to ascertain power available at outlet</p> <p>Check circuit breaker</p> <p>Call maintenance for assistance</p>
<p><b>System is turned “ON” but there is no sound</b></p> <p><b>or</b></p> <p><b>System is in standby and does not “wake up”</b></p>	<p>Turn “ON” microphone/ transmitter; the “TL” power button will illuminate to solid Blue when turned ON</p> <p>If the power button is illuminated red, the battery is low</p> <p>Ensure the mic is not muted (blinking light on mic indicates it is muted)</p> <p>Ensure gain/volume control knob on amplifier/receiver is turned up to mid-scale (12 o'clock position)</p> <p>On amplifier/receiver, ensure a green LED is illuminated just below Ch A or Ch B knob (depending on the microphone used).</p> <p><b>If no LED is illuminated:</b></p> <ul style="list-style-type: none"> <li>• Check the green LED on the ceiling sensor</li> </ul> <p><b>If sensor LED is not lit:</b></p> <ul style="list-style-type: none"> <li>• Sensor has been disconnected (check cable plug ends), or</li> <li>• Power output to sensor has failed (Sensor or amplifier may need to be replaced)</li> </ul>
<b>Voice is distorted and/or signal drop-out occurs</b>	<p>Verify that the sensor is not being covered</p> <p>Verify there is no obstruction between microphone and sensor</p> <p>Ensure there is no direct sunlight on sensor</p> <p>Ensure no other IR mics in room are turned on</p> <p>If sensor is mounted on a dark surface or without a flush ceiling surface, reception can be hampered.</p>

**Spectrum™ (IMA-840)**

<b>Amplifier Output Power</b>	100 W RMS, 4 x 25 W channels
<b>Receiver Input</b>	Infrared FM, 2 wireless mic channels
<b>Modulation</b>	Wide-band FM
<b>Reception Frequencies</b>	Ch. A: 2.08 MHz   Ch. B: 2.54 MHz
<b>Deviation</b>	10 kHz Nominal, 25 kHz Maximum
<b>De-emphasis</b>	50 $\mu$ s
<b>Tone Key</b>	32.768 kHz
<b>Infrared Wavelength</b>	850 nm
<b>External Sensor Input</b>	2, RCA, powered ports
<b>Connectivity Coverage</b>	1,600 sq ft per sensor, up to 2 sensors supported
<b>Total Harmonic Distortion</b>	<1% @ 1 kHz
<b>Frequency Response</b>	20 Hz - 20 kHz, $\pm$ 3 dB
<b>Line Level Inputs</b>	4: 1 x dual RCA, 3 x 3.5 mm
<b>Anti-Hum Balun</b>	Present on 1 Aux input for computer
<b>Wired Mic Input</b>	1 aux input switchable to mic input
<b>Line Outputs</b>	Conferencing: 3.5 mm with gain control - front panel Assistive Listening System: 3.5 mm with gain control - rear panel
<b>Page Input</b>	2-pin Phoenix; 4 V, 25 V or 70 V normal
<b>Page Input Sensitivity</b>	51 mV min
<b>Security Alert</b>	Contact Closure (COM, N/O, N/C)
<b>Fire Alarm</b>	Contact Closure by fire panel mutes audio
<b>Output Impedance</b>	Rated Load: 4 $\Omega$ minimum impedance
<b>Equalization</b>	5-band, $\pm$ 10 dB
<b>S/N Ratio</b>	65 dB
<b>Speaker Connection</b>	4-pin Phoenix Connectors
<b>Charger Output</b>	5 VDC, USB
<b>Power Supply</b>	19 VDC / 6.3 A CE, CSA and UL Listed
<b>Dimensions</b>	8 1/2" W x 1 3/4" H x 7 1/2" D
<b>Weight</b>	2 lb 6 oz

**Power Supply (AC-36)**

<b>Type</b>	Regulated Switching Power Supply, CE, CSA and UL listed
<b>Input Voltage</b>	100-240 volts AV, 47-63 Hz
<b>Output Voltage</b>	19 VDC, 3.43 A
<b>Power Output</b>	65 watts max

## Sapphire (IRT-60) microphone/transmitter specs

<b>Transmission Carrier</b>	Infrared
<b>Transmission Frequencies</b>	2.08 MHz & 2.54 MHz
<b>Channel Selection</b>	Field Switchable
<b>Transmitting Diodes</b>	Six
<b>Wavelength</b>	850 nm
<b>Modulation</b>	FM Wide-Band
<b>Frequency Response</b>	100 Hz - 10 KHz
<b>Pilotone Frequency</b>	32.768 KHz
<b>Peak Deviation</b>	± 25 KHz
<b>Dynamic Range</b>	95.5 dB @ 2.8% THD
<b>Operating Range</b>	60 Ft. line of sight
<b>Latency (mic to speakers)</b>	0.87 ms
<b>Battery Used</b>	Lithium-ion polymer (3.7V / 620mAh)
<b>Battery Life</b>	8 hr/Charge
<b>External Power Charger</b>	5V DC Micro USB Connector
<b>Transmission Angle</b>	180° Conical
<b>User Controls</b>	
<b>Power (On/Off)</b>	Press & Hold
<b>Mute Switch (On/Off)</b>	Momentary Press (blinks when muted)
<b>Add'l Mic Gain Control</b>	Normal, -3dB, -6dB
<b>Audio Source Vol./Gain</b>	Increase, Decrease
<b>Channel Select</b>	(A or B) in battery compartment
<b>External Mic/Aux Input</b>	3.5 mm Line Level
<b>Dimensions (H x W x D)</b>	3.5" x 1.25" x 0.75"
<b>Weight</b>	1.4 oz including battery

## Handheld (IRT-35) microphone/transmitter specs

<b>Transmission Carrier</b>	Infrared
<b>Transmission Frequencies</b>	2.08 MHz & 2.54 MHz
<b>Channel Selection</b>	Field Switchable
<b>Transmitting Diodes</b>	Ten
<b>Wavelength</b>	850 nm
<b>Modulation</b>	FM Wide-Band
<b>Pilotone Frequency</b>	32.768 KHz
<b>Peak Deviation</b>	± 25 KHz
<b>Operating Range</b>	50 ft. line of sight
<b>Power Switch (Slide)</b>	On/Off
<b>Battery Charge Level (LED)</b>	Green: Full   Orange: Medium   Red: Low
<b>Battery Life</b>	Approx. 7 Hr./Charge
<b>Dimensions</b>	2.125" dia. (Head), 1.4375" dia. (Body), 9.625" H
<b>Weight</b>	10.3 oz. w/ Battery



**TeachLogic™**

541 Main St. Longmont, CO 80501

TeachLogic.com | Support@TeachLogic.com | 760-631-7800