



# SPECTRUM™ III CLASSROOM AUDIO SYSTEM

## INSTALLER AND OPERATIONS MANUAL



Amplifier

Audio Mixer

Infrared Microphone Receiver

Spectrum III

owner's manual



## notes

Date of Purchase: \_\_\_\_\_

Model Number: \_\_\_\_\_

Serial Number: \_\_\_\_\_

Notes:



### thank you

Congratulations on the purchase of your new TeachLogic system. You can be assured that this fulfills all specifications and was produced to very high quality control standards. TeachLogic incorporates the latest state of the art technology, employs the most advanced manufacturing methodology and uses only premium quality components to assure many years of reliable performance. We appreciate your confidence by your selection of our product. It is TeachLogic's intent to uphold that confidence by providing factory assistance and dealer support.

We hope you will take the time to review this manual to familiarize yourself with the product operation and features. This manual will help you learn to use and gain the maximum benefit of the system.

TeachLogic, LLC  
Longmont, Colorado, USA  
teachlogic.com

### contact

If you should encounter some unresolved issue, please contact TeachLogic customer service department for further assistance.

☎ 1-760-631-7800

✉ support@teachlogic.com

🌐 www.teachlogic.com



## CAUTION

**RISK OF ELECTRIC SHOCK:  
DO NOT OPEN**

Caution: To Reduce The Risk Of Electric Shock Do Not Remove Cover (Or Back)  
No User-serviceable Parts Inside  
Refer Servicing To Qualified Personnel

## certifications



TeachLogic systems are manufactured using lead-free processes and are free of materials harmful to the environment. They conform to the most stringent new European guidelines for consumer products (RoHS).

## caution

Recycle—Do not dispose rechargeable batteries in trash. Actually it is unlawful to do so in CA, NY & ME.

Contact: Earth911.com  
1-800-CLEANUP

Save our resources and don't contaminate.  
Go Green

## safety instructions

### Read Instructions

All safety and operation instructions should be read before operating this TeachLogic product.

### Retain Instructions

Safety and operating instructions should be kept for future reference.

### Water & Moisture

This product should not be operated near water.

### Heat Environment

Do not subject this product to excessive heat conditions.

### Power Source

This product must be connected to an AC power source per the voltage input specified and marked on the power supply.

### Power Cord Caution

Power cable should be routed clear of foot traffic and supported clear of kinking or abrasion.

### Object Protection

Locate the operating unit so it will not be subjected to falling objects or water entry.

### Internal Service

User should not attempt to service this product. All internal service must be accomplished by a qualified technician.

### Electric Shock

Do not adapt or modify the AC power plug thus lifting the earth ground connection.

### table of contents

About Infrared .....	1
Product Description .....	2
Spectrum III System Description IMA-820.....	3
Sapphire Microphone/Trasmitter IRT-60 .....	4
Handheld Microphone/Trasmitter IRH-35 .....	5
Drop-in Charger BRC-60/Ceiling Sensor ICS-55 .....	6
Installation of Ceiling Sensor .....	7
Installation of Ceiling Speakers .....	8
Installation of Wall Mount Speakers .....	9
System Wiring .....	10-11
Page Pass Through .....	12
Fire Alarm .....	13
RS-232 Features .....	14
Security Alert Features .....	15
Operation of Wireless Microphone .....	16
Trouble Shooting .....	17
System Specifications .....	18-19
Five Year Limited Warranty .....	20



## IR transmission

The IR transmitter transmits directly to the sensor. However, due to the strength of the IR transmitter, the infrared signal will bounce off the walls, ceiling and floor for reception thus providing continuous connectivity throughout the room. Benefit: total freedom of movement within the room with no restriction of orientation.

“What’s said in the room, stays in the room”.

Infrared will not penetrate a solid surface thus preventing any transmission from going out of the room.

## a brief word about infrared

Infrared is a light ray that is below the visible spectrum, just like the sound extends beyond your hearing ability. An example of infrared transmission is the remote control for your TV set. When a button is pressed, a beam of infrared light is emitted by a Light Emitting Diode (LED) from the remote control. It is detected by a receiving diode in your TV set. When you press a certain command on your control, the internal electronics cause the infrared light to flicker in a programmed sequential pattern (called modulating the light beam). The modulated infrared beam is detected by the receiving diode and is electronically decoded. The decoded signal activates the circuitry to perform the command function on your TV set.

So how does this apply to the infrared communication system you are about to start using? The microphone/transmitter has several Light Emitting Diodes (LED) that emit infrared light beams to the sensor located in the corner of the room. Now when you talk into the microphone, the microphone element modulates the light beam, causing it to flicker in sync with your speech. The sensor detects the sequential signal and the electronic circuitry in the Spectrum III converts that sequential signal into a line level analog audio signal. Now that audio signal can be fed into an amplifier. The amplifier magnifies the electronic signal and sends it to the speakers. This causes the speaker cone to move in sync with your voice. The speaker replicates your voice and disperses your voice evenly throughout the room.

### product description

The Spectrum III is an infrared wireless microphone system that can be added to any sound system. It can be a supplement to an existing multi-media system to expand it's utilization to provide voice reinforcement.

The addition of a Spectrum III system to your multi-media system will transform your classroom sound system into a totally hands free voice re-enforcement system, resulting in reduced voice fatigue, enhanced student listening and improved student learning. The wireless function permits 360° connectivity throughout the classroom regardless of body position or orientation.

The system is comprised of an infrared detecting sensor(s) installed in the ceiling. The sensor collects the IR wireless signal from the microphone/transmitter and sends a composite signal to the receiver. The receiver transforms the composite signal into an analog audio signal which is fed to the multi-media amplifier. The amplifier powers the speakers for even voice reinforcement throughout the room.

The microphone / transmitter can be the Sapphire or Handheld. The rechargeable batteries will provide 6 – 8 hours of service per charge. The drop-in charger will recharge the batteries overnight, ready for another day's use.

Reliable  
performance.  
Use with  
confidence.



## front of IMA-820 receiver/amplifier

- |                                  |                                  |
|----------------------------------|----------------------------------|
| 1 Power on/off                   | 6 Aux Volume Control             |
| 2 CH A Microphone Volume Control | 7 MP3 Volume Control             |
| 3 CH B Microphone Volume Control | 8 MP3 Input (3.5mm)              |
| 4 DVD Volume Control             | 9 Lesson Capture Volume Control  |
| 5 Computer Volume Control        | 10 Lesson Capture Output (3.5mm) |

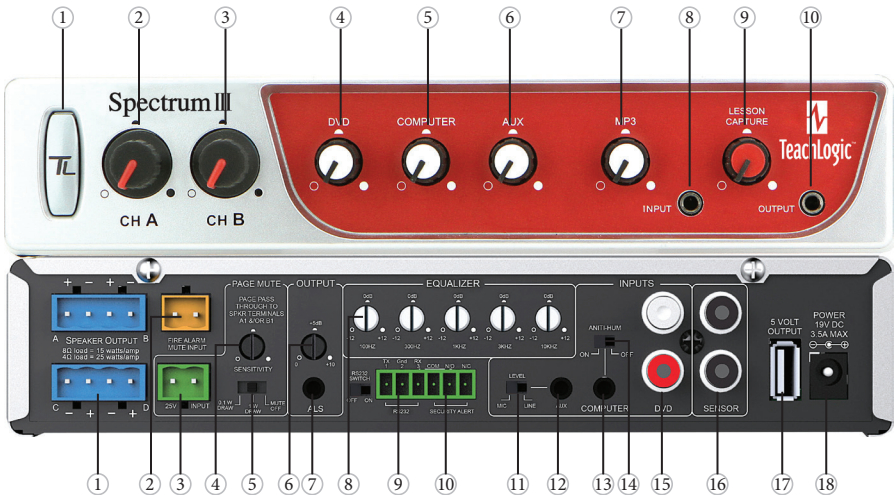

## back of IMA-820 receiver/amplifier

- |   |                                     |
|---|-------------------------------------|
| 1 Speaker Output                          | 10 Security Alert - contact closure |
| 2 Fire Alarm Input - contact closure      | 11 Aux-Mic Input Selector           |
| 3 Page Input                              | 12 Aux-Mic Input (3.5mm)            |
| 4 Page Sensitivity control                | 13 Computer Input (3.5mm)           |
| 5 Page impedance selector                 | 14 Computer Anti hum ON/OFF         |
| 6 ALS gain control                        | 15 DVD dual Mono Inputs (RCA)       |
| 7 ALS Output (3.5mm)                      | 16 Two IR Mic Sensor Inputs (RCA)   |
| 8 Five band digital equalizer $\pm 12$ dB | 17 5 Volt USB output for BRC-60     |
| 9 RS-232 (Tx,Gnd,Rx) 3-pin                | 18 Power Input: 19 VDC 6.3A         |

### infrared microphone/transmitters

The infrared microphone/transmitter is comprised of a microphone input, signal processing circuits and several emitting diodes that transmit the vocal signal to the sensor.

The microphone/transmitter can be the Sapphire or Handheld. The rechargeable batteries will provide 6–8 hours of service per charge. Place the microphone/transmitter in the charger for overnight charge and it will be ready for another day's use.

The drop-in battery chargers are specifically designed to recharge lithium & NiMH batteries at an optimum rate for maximum operating capacity and extended service life. Charger will automatically start charging the batteries upon insertion and will shift to a maintenance charge when batteries are fully charged.

#### features

- Elegant design
- Only 1.4 oz. including battery
- Long life “Lithium ion” battery
- Rechargeable via USB cable to computer
- Battery level indicator – Back light under power switch
- Momentary mute button, backlight blinks in mute mode
- Push “on/off” power
- Channel “A” or “B” selectable
- Three level microphone volume switch
- (Normal, -3dB, -6dB)
- Auxiliary input (3.5mm)
- Wear with a lanyard or slide directly on neckline collar



#### (IRT-60) sapphire transmitter

The Sapphire's vocal clarity is unsurpassed. Its high level output is achieved by the unidirectional (Cardioid) microphone and a unique free air suspension system. With a built-in breath filter, the Sapphire can function as a pass around hand mic.

The strategic alignment of the emitting diodes assures reliable connectivity throughout the room without static or drop out.

With a tap on the power button, the microphone is muted for private conversation—tap again to restore to normal operation. The auxiliary input allows wireless playback of your iPod™ through the Sapphire. A three position slide switch provides selection of low, medium, or high microphone sensitivity.





## IRT-60 remote control features

1. Moving the priority switch Up/Down will control the volume of the line inputs.
2. A momentary tap of the priority switch will duck down the line inputs 15dB. The receiver front panel power switch changes to a blinking PURPLE. A second tap will restore line input back to normal.
3. Hold in priority switch for 5 seconds closes the contact closure on the Security Alert output. The receivers front panel power switch changes to blinking GREEN. Holding the button down for another 5 sec. returns the contact to normal.

## features

- Condenser microphone element
- Power “on/off” switch
- Battery level indicator—LED
- Channel “A” or “B” selectable
- 10 high-power emitting diodes
- Diodes at top and bottom of handle for increased Coverage (2 Top aimed out, 6 Bottom 360°, 2 Bottom aimed down)
- 360° IR radiation for assured connectivity
- Two “AA”, Duracell, rechargeable NiMH batteries



## IRH-35 handheld transmitter

The Handheld Microphone Transmitter (IRH-35) is most applicable for student use or direct presentation. It has an “on/off” switch and a battery level indicator LED; Green=useable charge, Red=low battery. The transmitter has 10 emitting diodes: 8 around the bottom of the handle, and 2 toward the top of the handle. The metal housing provides low handling noise and insures durable longevity.

### BRC-60 drop-in battery charger

This stylish desktop drop-in charging station makes it convenient and easy to recharge both Sapphire Pendant and Handheld Microphones. Charge one IRH-35 handheld transmitter and up to two IRT-60 Sapphire transmitters simultaneously. Charging indicator lights illuminate Red when charging, and Green when fully charged. The power LED illuminates Blue when plugged in.



### power "on" LED

Green light indicates that the sensor is receiving power from the receiver.

### ICS-55 ceiling sensor

The ceiling sensor is the preferred infrared sensor for optimum performance. This is the unit that needs to be installed on the ceiling. It comes with a mounting/support bracket and 50 feet of plenum rated cable with RCA connector on each end. The ideal location for the dome sensor would be in the center of the ceiling. This will provide a clear signal path for the IR transmission from the transmitter to the dome sensor without obstruction. In addition, you will have 360° coverage and will minimize the transmission distance for more reliable performance. It collects the infrared transmission signal via 6 large detecting diodes.

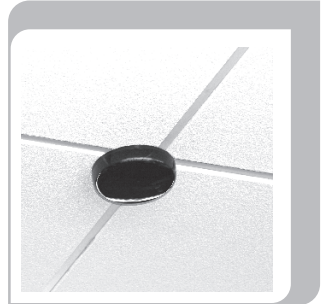

### sensor cable

A Cable connects the sensor to the receiver. The cable is dual-shielded with a male RCA connector on each end and is plenum rated.



## installation of ICS-55 ceiling sensor

The ideal location for the ceiling sensor is in the center of the ceiling. This will provide a clear signal path for the IR transmission from the transmitter to the dome sensor without obstruction. In addition, you will have 360° coverage and will minimize the transmission distance for more reliable performance.

### Attaching the infrared ceiling sensor

Installation 1 ----- Attach to T-bar Rail

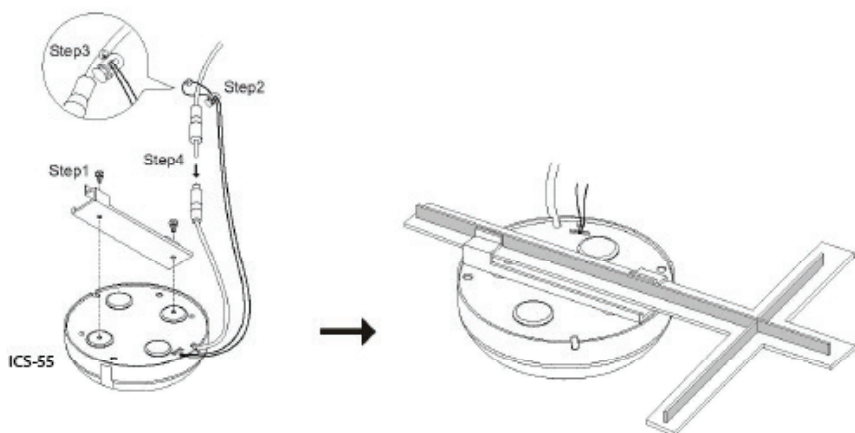

Installation 2 ----- Attach to wood surface

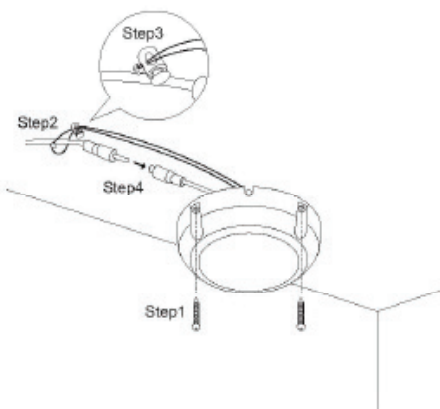

Installation 3 ----- Attach to concrete surface

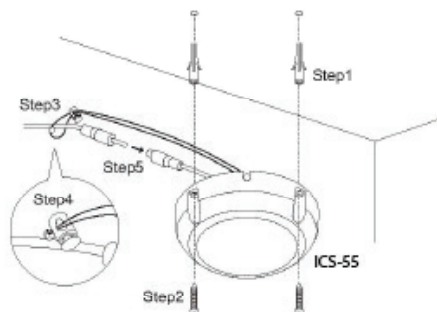

## installation of speakers

Two wall mount or ceiling speakers can be powered by the receiver/amplifier. It has two amplifiers (25 watts ea.). One speaker will be connected to each amplifier.

Optional: Two additional speakers can be powered by the amplifier. Connect two speakers in parallel. Then bring a cable from each pair to the amplifier. Connect one pair to each amplifier.

### installing two SP-628 ceiling speakers

- Determine the listening area.
- Divide listening area into two quadrants
- Locate and identify the center most tile in each quadrant
- Lay ceiling tile face down on clean flat surface
- Lay tile bridge on ceiling tile and center it
- Trace and cut the large hole using a keyhole or drywall saw
- Strip the speaker cable ends, approx. ½"
- Route speaker wire from speaker opening to amplifier
- Reinstall ceiling tile with tile bridge in place above the hole
- Pull speaker cable back down through speaker hole
- With a pointed tool or paper clip, lift up and remove speaker grille
- Set speaker on top of ladder and connect speaker cable connect
- Observe speaker polarity, connect Red wire to (+) terminal and black wire to the (C) terminal
- With the mounting clamps folded back, position speaker into speaker hole
- With a #2 Phillips screwdriver, tighten the quick clamps
- Reinstall speaker grille and remove any soil or fingerprints
- Repeat same for other speaker

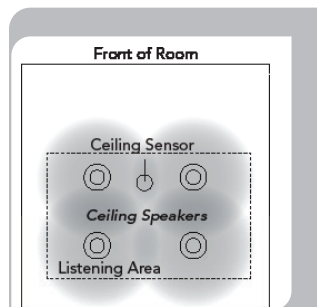
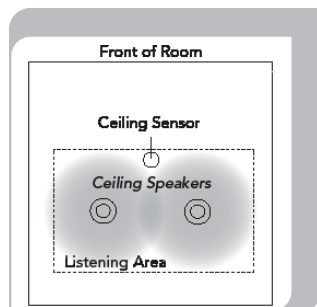

**Optional:**  
Two Additional Speakers

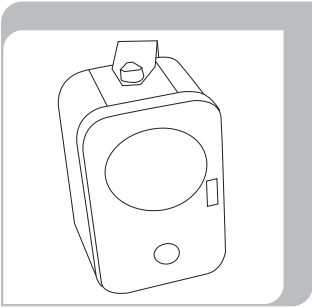

## installing SP-2000 wall mount speakers

- First observe the shape of the room: ceiling height, door locations, windows, mounting surface, and seating area
- Ordinary installation would be to locate the speakers on each side wall approximately even with the front row of listeners
- Mount the speakers 6–7 feet above the floor
- Install the mounting brackets in the vertical (up/down) orientation
- Mount brackets using the appropriate hardware
- Insert speaker with the tweeter in upper position
- Secure speaker in bracket with the hand fasteners
- Orient each speaker toward the center of that half of the listening area
- Strip speaker cable ends  $\frac{1}{2}$ " and connect to speaker
- Observe speaker polarity: Connect (+) wire (with printed writing) to (+) terminal and (-) wire (unprinted & textured) to the (-) terminal
- Route speaker cable to the receiver/amplifier in a safe, least visible, tidy manner

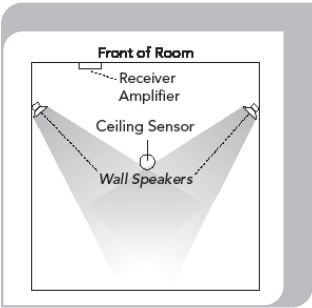

## final connection of the system

With receiver/amplifier located, speaker and sensor cables neatly routed, we are ready to complete the installation.

- Cut the speaker wire to the appropriate length
- Strip about  $\frac{3}{8}$ " off the end of each speaker wire.
- Twist the wire and if you have a soldering iron, tin the wire ends
- Unplug the phoenix connector, insert (+) wire (with printed writing) into either outside (+) terminal. Plug the other (-) wire into center (-).
- Tighten set screws.
- Repeat for other pair and insert plug firmly into speaker receptacle
- Plug power supply into AC outlet

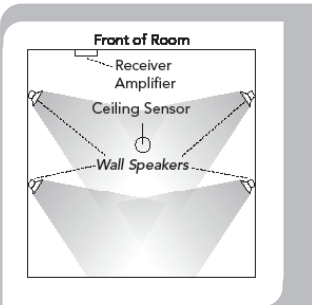

**Optional:**  
Two Additional Speakers

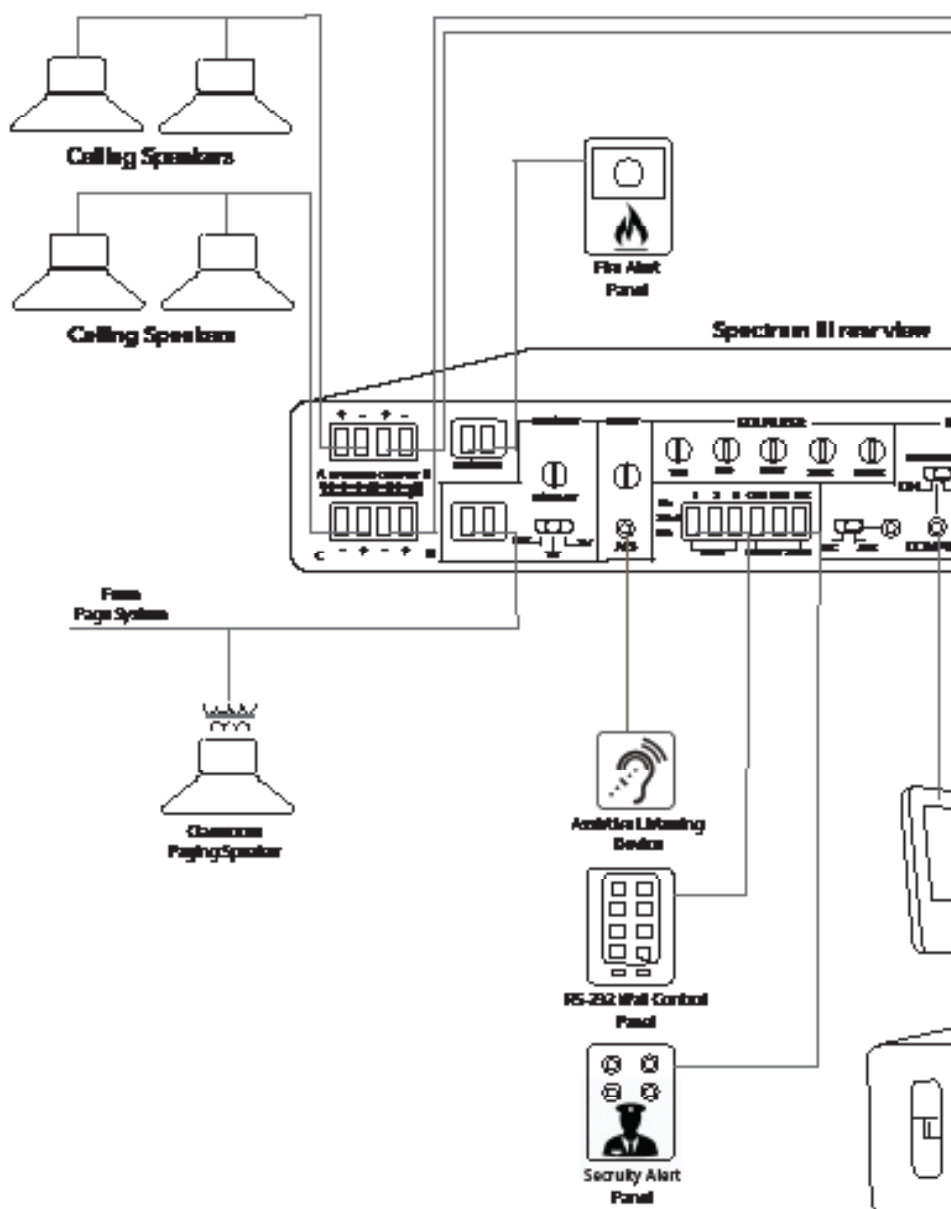



# system wiring

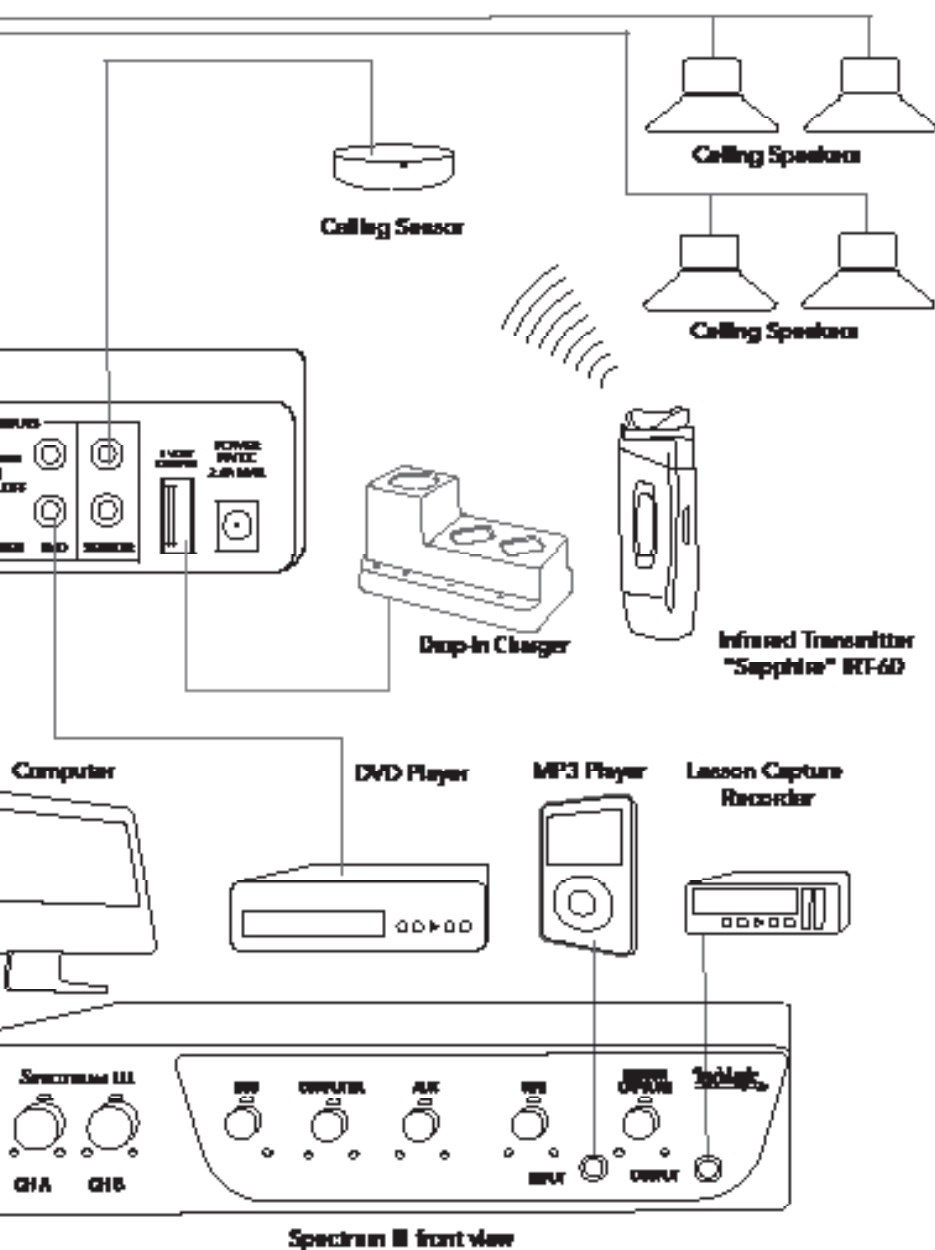

## page over-ride/page pass through

The page over-ride feature allows you to connect the TeachLogic amplifier to the school paging/intercom system for muting purposes. A simple connection between the in-classroom paging speaker (typically 25v or 70v) and the TeachLogic page input will mute all the inputs and pass the page to the speakers connected to the TeachLogic amplifier. The panel labeling is based on a 25-volt paging input signal.

The Page Input impedance switch has three labeled positions (based on power draw at 25V):

- 0.1W DRAW
- 1.0W DRAW
- MUTE OFF

Switch Setting:	0.1W DRAW	1W DRAW	MUTE OFF
Impedance	5000 $\Omega$	620 $\Omega$	Open circuit
Power Draw at 25V	0.1W	1.0W	0W
Power Draw at 70V	1.0W	7.9W	0W

Older Models:

Switch Setting:	100V	70V	25V
Impedance	5000 $\Omega$	620 $\Omega$	115 $\Omega$
Power Draw at 25V	0.1W	1.0W	5.3W
Power Draw at 70V	1.0W	7.9W	42W

1. Unplug the 2 pin green Phoenix connector
2. Connect the speaker cable from the paging system to the 2 pin Phoenix connector of the Page input
3. Reconnect the 2 pin green Phoenix connector
4. Determine the signal level of the paging system (25v or 70v)
5. Set the slide switch to the appropriate speaker level setting
6. With the TeachLogic amplifier turned ON, send a page signal through the page input
7. Adjust the page input SENSITIVITY control so that an incoming page/intercom signal will override any audio (mics, dvd etc) plugged into the TeachLogic amplifier.

## page over-ride/page pass through

In the event of a loss of AC power, the TeachLogic amplifier will continue to pass the page on to only one of the speaker connections as outlined on the following diagram. Only the upper left speaker outputs will pass page without power.

## page pass through

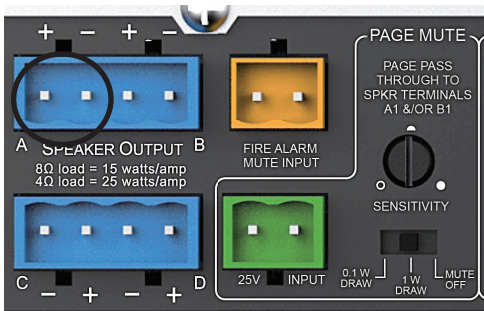

## fire alarm input

The 2 pin orange Phoenix connector labelled Fire Alarm, was designed to provide an emergency mute of the TeachLogic amplifier. When interfaced to the fire alarm panel relay contact output, all audio devices (microphones, dvd, etc.) will turn SILENT. In the event of a fire, this will help to lower the overall decibel levels and help students and staff hear the audible fire alarm tones/instruction within the classroom. This feature only requires a contact closure from the Fire Alarm Panel.

### RS-232 features

The RS-232 feature allows the user to remotely operate the line level media inputs via a convenient wall panel controller.

Audio levels very often need to be adjusted when switching from computer audio to DVD players and other audio sources. Such operations as level UP, DOWN and MUTE are easily accomplished via a typical eight button controller, as shown here. This allows the receiver/amplifier to be placed in an area or compartment that is not easily accessed by the user. Codes that are required for this setup are also available below or from TeachLogic's website.

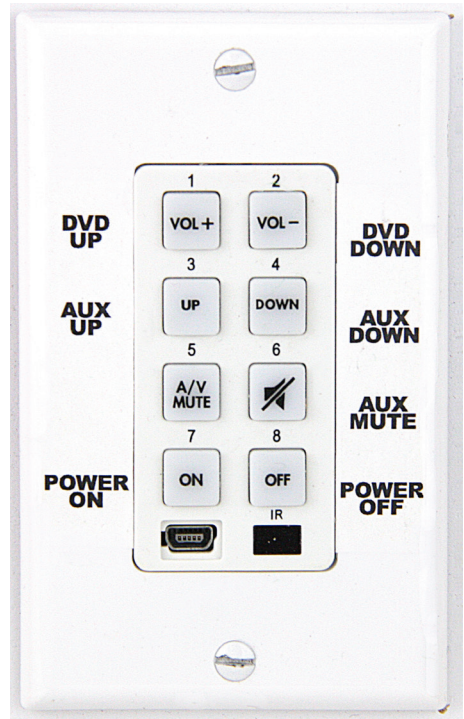

### RS-232 codes

Baud Rate : 9600	Spectrum III	
Parity Bit : NONE		
Data Bit : 8		
Stop Bit : 1		
Product Function	TL COMMAND - SpectrumIII	HEX command String
POWER ON	Power:ON	4c 69 6e 6b 78 3a 50 6f 77 65 72 3a 4f 4e 0D
POWER OFF	Power:OFF	4c 69 6e 6b 78 3a 50 6f 77 65 72 3a 4f 46 4e 0D
Gain DVD UP	Gain:AUX:UP	4c 69 6e 6b 78 3a 47 61 69 6e 3a 41 55 58 3a 55 50 0D
Gain DVD DOWN	Gain:AUX:DOWN	4c 69 6e 6b 78 3a 47 61 69 6e 3a 41 55 58 3a 44 4f 57 4e 0D
Gain DVD MUTE	Gain:AUX:MUTE	4c 69 6e 6b 78 3a 47 61 69 6e 3a 41 55 58 3a 4d 55 54 45 0D
Gain Computer UP	Gain:DVD:UP	4c 69 6e 6b 78 3a 47 61 69 6e 3a 44 56 44 3a 55 50 0D
Gain Computer DOWN	Gain:DVD:DOWN	4c 69 6e 6b 78 3a 47 61 69 6e 3a 44 56 44 3a 44 4f 57 4e 0D
Gain Computer MUTE	Gain:DVD:MUTE	4c 69 6e 6b 78 3a 47 61 69 6e 3a 44 56 44 3a 4d 55 54 45 0D
Gain MP3 UP	Gain:MP3:UP	4c 69 6e 6b 78 3a 47 61 69 6e 3a 4d 50 33 3a 55 50 0D
Gain MP3 DOWN	Gain:MP3:DOWN	4c 69 6e 6b 78 3a 47 61 69 6e 3a 4d 50 33 3a 44 4f 57 4e 0D
Gain MP3 MUTE	Gain:MP3:MUTE	4c 69 6e 6b 78 3a 47 61 69 6e 3a 4d 50 33 3a 4d 55 54 45 0D
Gain AUX UP	Gain:MIC:UP	4c 69 6e 6b 78 3a 47 61 69 6e 3a 4d 69 43 3a 55 50 0D
Gain AUX DOWN	Gain:MIC:DOWN	4c 69 6e 6b 78 3a 47 61 69 6e 3a 4d 69 43 3a 44 4f 57 4e 0D
Gain AUX MUTE	Gain:MIC:MUTE	4c 69 6e 6b 78 3a 47 61 69 6e 3a 4d 69 43 3a 4d 55 54 45 0D
CH A MUTE	CH:A:MUTE	4c 69 6e 6b 78 3a 43 48 3a 41 3a 4d 55 54 45 0D
CH B MUTE	CH:B:MUTE	4c 69 6e 6b 78 3a 43 48 3a 42 3a 4d 55 54 45 0D



## security alert features

The security Alert features allows the teacher/presenter to send a silent wireless electronic signal with a simple press of a button, in the event of an in-classroom security incident. The signal is easily generated by the teacher who is wearing Sapphire wireless pendant microphone. This same microphone transmitter which is used for in-room amplification, has a special button (labelled PRIORITY) on the side for initiating the Security Alert. Simply holding down the button for 4 seconds, "closes" a contact closure on the rear panel of the TeachLogic amplifier and sends the Security Alert signal to the appropriate location possibly the principal's or security monitoring station. The front panel power switch on the front of the amplifier will "blink" with a soft green background.

To disengage from the Security Alert mode, simply hold the side button for 4 seconds, and the amplifier will return to its normal state with the front panel power button illuminated with a solid blue background.

The output is a three pin NO/NC contact closure labeled Security Alert.

## RE-232 and Security Alert contacts

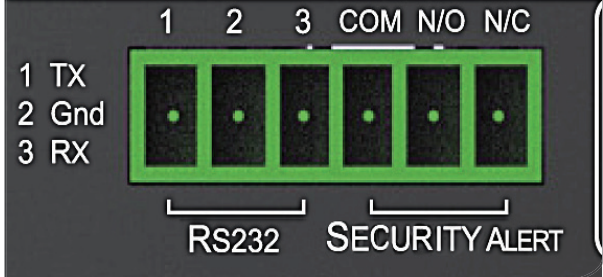

### operation of wireless microphone

Now that the system is installed and connected, we are ready to turn the system "ON" and test its performance. The testing will be done using an IR transmitter (Sapphire or Handheld) to confirm good connectivity and quality audio.

#### system operation

- Turn the Spectrum III "ON", Blue LED will light
- Confirm power to sensor, Green LED on edge of sensor
- Set volume of Ch A volume control to mid scale (12 o'clock)
- Using a Sapphire Transmitter microphone select channel "A" (Mics are shipped in channel A)
- Sapphire: "A-B" switch, remove battery cover on back, under battery.

Handheld: Unscrew barrel and remove.

Note "A-B" switch on side of battery holder.

- Turn volume control on Sapphire transmitter to "Hi" level. This is the normal setting.
- Switch transmitter "on"
- Observe power LED (Blue) - use fully charged battery only
- Observe signal presence LED (Orange) on receiver adjacent to "Mic" volume control
- Stand under or in front of a speaker
- Slowly adjust "Ch A" volume on Spectrum III while talking into microphone
- Adjust to desired listening level.
- CAUTION: Beware of feedback
- Walk around the room while talking into microphone to confirm good connectivity

Upon completion of performance test, the installation is complete.

## troubleshooting

Problem	Solution
System is turned “on” but there is no sound	<ul style="list-style-type: none"><li>• Verify AC power; the Blue LED lights when turned “on”</li><li>• Check if system has been unplugged</li><li>• Check circuit breaker</li><li>• Call maintenance for assistance</li></ul>
System has power but no sound	<ul style="list-style-type: none"><li>• Turn “on” microphone/transmitter</li><li>• Check for IR transmission, Signal presence (Orange LED)</li><li>• Check the Green LED on the sensor</li><li>• If sensor LED is not lit<ul style="list-style-type: none"><li>• Sensor has been disconnected</li><li>• Power output to sensor has failed (Receiver/amplifier needs to be replaced)</li></ul></li></ul>
Voice is distorted and/or signal drop-out occurs	<ul style="list-style-type: none"><li>• Check the charge on your batteries</li><li>• Verify that the diodes on transmitter or sensor are not being covered</li><li>• Obstruction between transmitter and sensor</li></ul>

## contact

If your problem persists and this guide has not resolved the issue, call our customer service department for additional assistance. (760) 631-7800

## Spectrum III (IMA-820) specs.

Receiver Input Modulation	Infrared FM FM Wide-band
Reception Frequencies	Ch. A: 2.08 MHz, Ch. B: 2.54 MHz
Infrared Wavelength	850 nm
Tone Signal	Ch. A: 32,768 KHz
De-emphasis	50 $\mu$ s
Frequency Response	50 Hz, -13KHz, C 3dB
S/N Ratio	>65 dB
THD	<1% @1KHz
Nominal Deviation	$\pm$ 10 KHz
Maximum Deviation	$\pm$ 25 KHz
External Sensor Input	Two, RCA
Aux Inputs	Four line level inputs for DVD, Computer, Aux and MP3 Switchable computer anti-hum circuit Aux input (Microphone or Line level)
Line Output	One Lesson Capture Output, 3.5mm with Gain Controls, Front Panel One ALS Output, 3.5mm with gain control, Rear Panel
Equalization	Five Band Digital $\pm$ 12dB
Security Alert Output	N/O, N/C contact closures
RS-232	Wall panel control of line input levels
Fire Alarm Input	Fire Alarm Panel - Contact Closure
Power Output	Four Amplifiers, 100 watts total (RMS) Four 25 watts ea. (RMS)
Output Impedance	40hm min, per channel
Output Connection	One Phoenix Connector, ch A,B,C&D
Power Supply	19VDC /6.3A / 120W CE,CSA & UL Listed
Dimensions	8 1/2" W x 1 3/4" H x 7 1/2" D
Weight	2 lb. 6oz.
Enclosure	Aluminum

## power supply (AC-80) specs.

Type	Regulated Switching Power Supply
Input Voltage	100-240 volts AC, 47-63Hz
Output Voltage	19 volts DC, 6.3A
Power Output	119.7 watts Max.



### Sapphire transmitter (IRT-60) specs.

Transmitting Diodes	Six
Operating Range	1,600 Ft <sup>2</sup> . 60 Ft. Line of Sight
Battery Discharge Indicator	
Blue	Full
Purple	Medium
Red	Low
Flashing Red	Very Low Battery
Battery Used	Lithium-ion (3.7V / 620mAh)
Battery Life	Approx. 8-9 Hrs/Charge
External Power Charger	DC +5V, Micro USB Connector
Transmission Angle	Conical
User Controls	
Power Switch (push)	On/Off
Mute Switch (push)	On/Off momentary push
Mic Switch (3 position)	Normal, -3dB, -6dB
Aux. Vol./Gain	Increase, Decrease
Security Alert	5 second hold of priority button
External Aux. Input	3.5mm Line Level
Dimensions	3 5/8" H x 1 1/4" W x 3/4" D
Weight	1.4 oz. Including battery

### Handheld transmitter (IRH-35) specs.

2 Channel Switchable	Field Switchable
Transmitting Diodes	Ten
Modulation	FM Wide-Band
Pilotone Frequency	32.768 KHz
Peak Deviation	± 25KHz
Operating Range	1600 Ft <sup>2</sup> . 60 Ft.
Power Switch (Slide)	On/Off
Battery Charge Level (LED)	Green (Useable Charge) Red (Needs Charging)
Battery Life	Approx. 7 Hr./Charge
Dimensions	21/8" Dia. Head, 17/16" Dia. Body, 95/8" H
Weight	10.3 oz. w/ Battery

### drop-in battery charger (BRC-60) spec

Charging Port	2 Sapphire, 1 Handheld
Red LED	Battery being charged
Green LED	Battery fully charged
Power Supply	5 VDC, 1 Amp
Dimensions	6 3/8" L x 3 3/8" W x 3 3/8" H
Weight	6.3 oz.

### five year limited warranty

Please refer to [www.teachlogic.com/warranty](http://www.teachlogic.com/warranty)

### contact

TeachLogic  
Customer Service Dept.

 1-760-631-7800

 [sales@teachlogic.com](mailto:sales@teachlogic.com)

 [www.teachlogic.com](http://www.teachlogic.com)





☎ 1-760-631-7800

✉ [support@teachlogic.com](mailto:support@teachlogic.com)

🌐 [teachlogic.com](http://teachlogic.com)

P/N UMM-800  
rev003 20200108