

Antenna / Antena

Ref. 148820

Kit: 148881



KIT	COMPOSITION
148881	Antenna 148820 + P.S.U. 550104

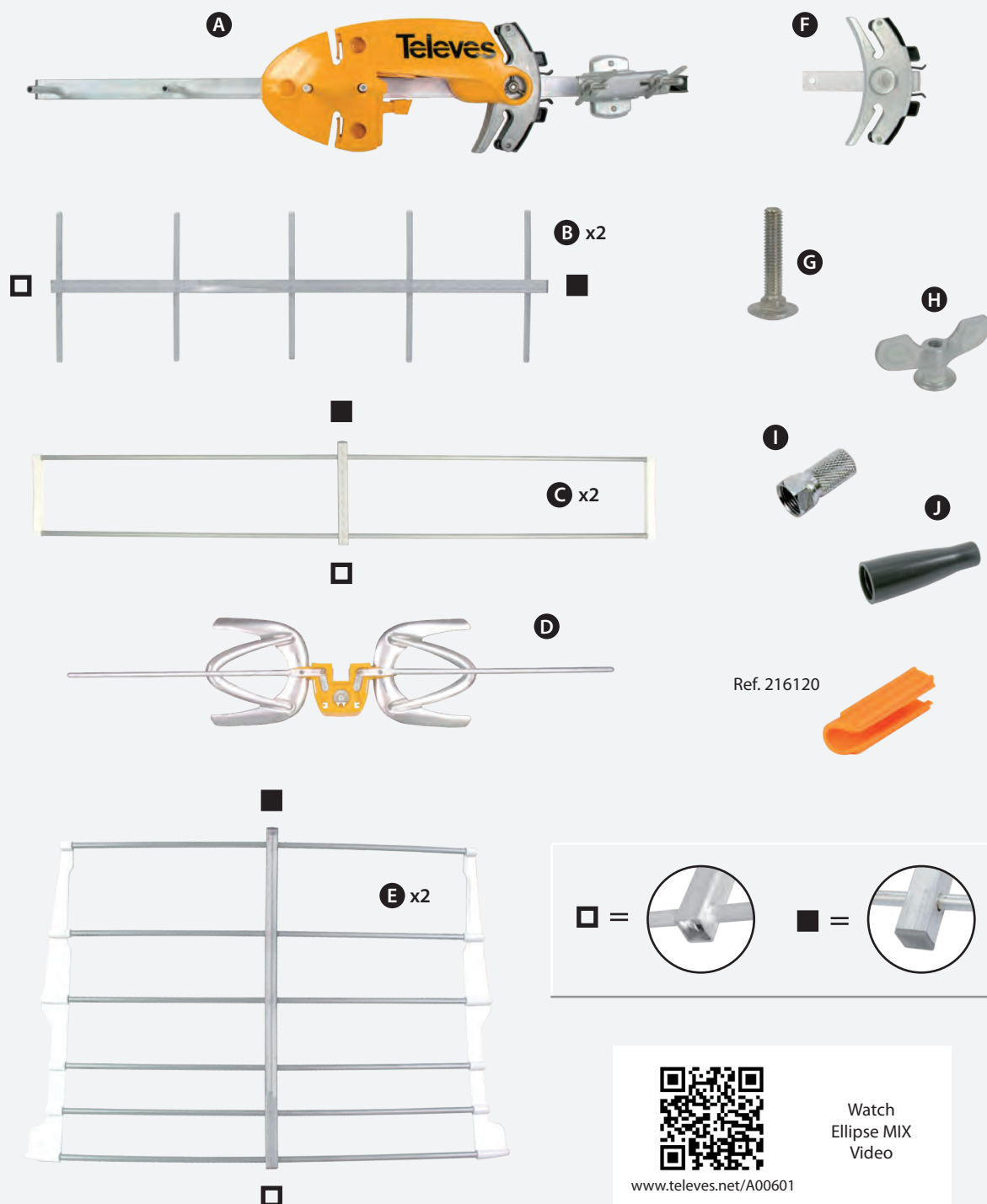

Ref. 216120



Watch
Ellipse MIX
Video

www.televes.net/A00601

Antenna mounting / Montaje de la antena

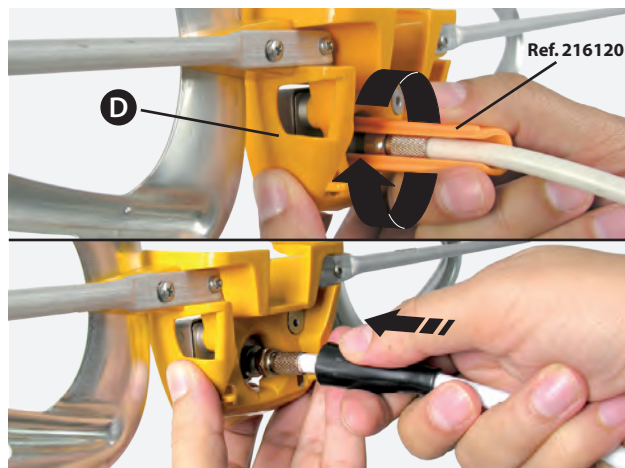
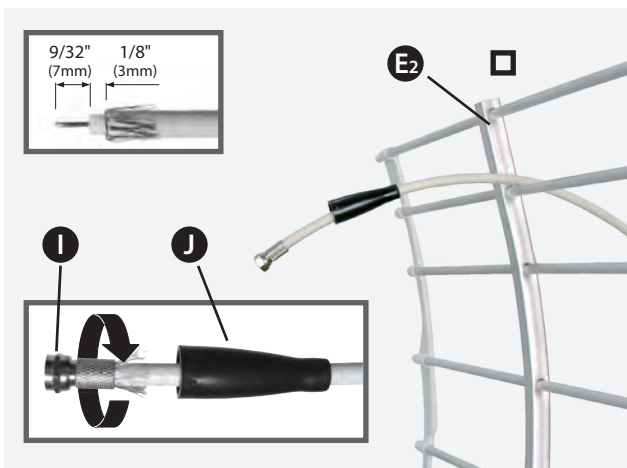
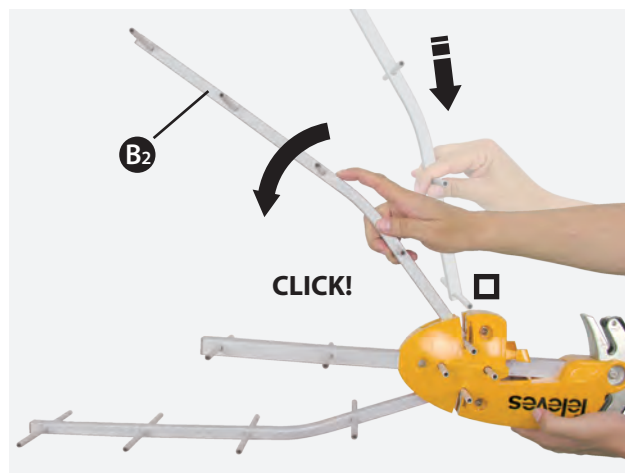
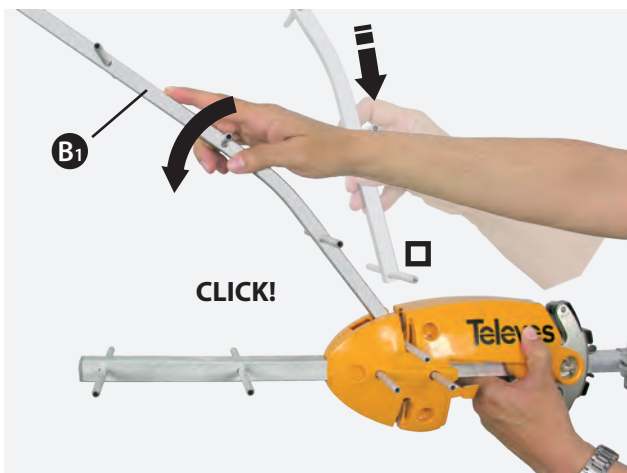
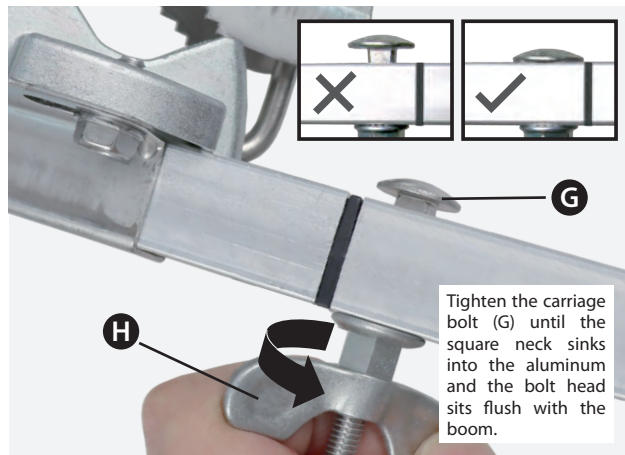
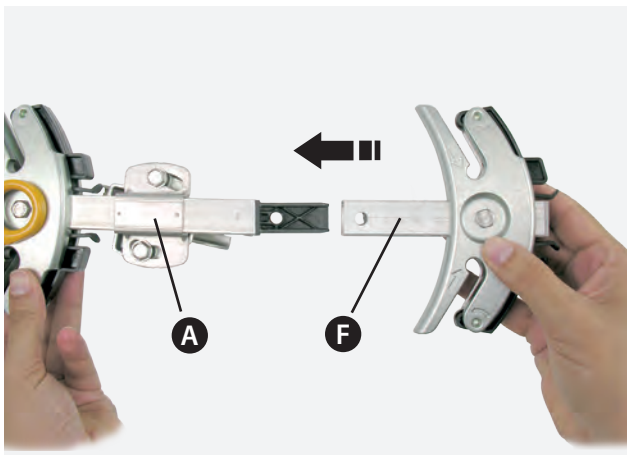

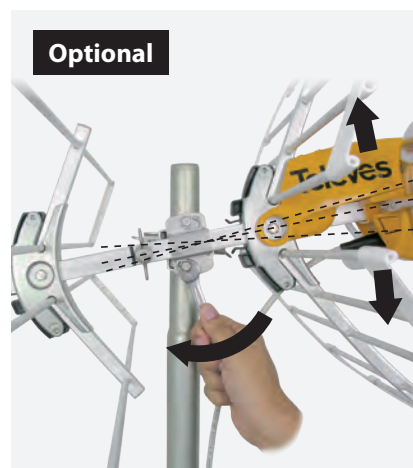
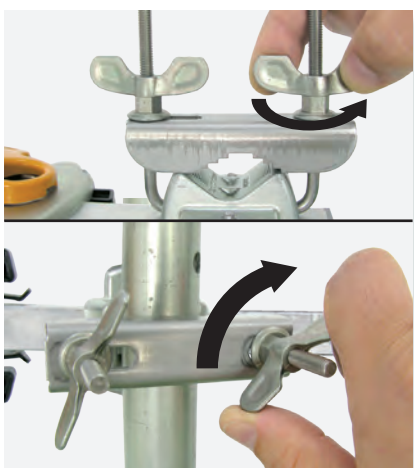
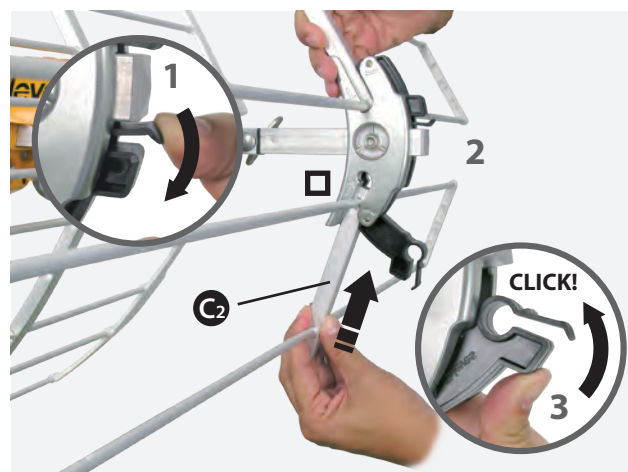
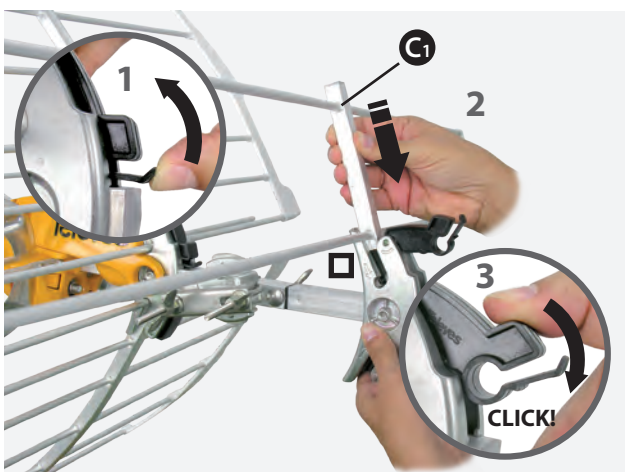
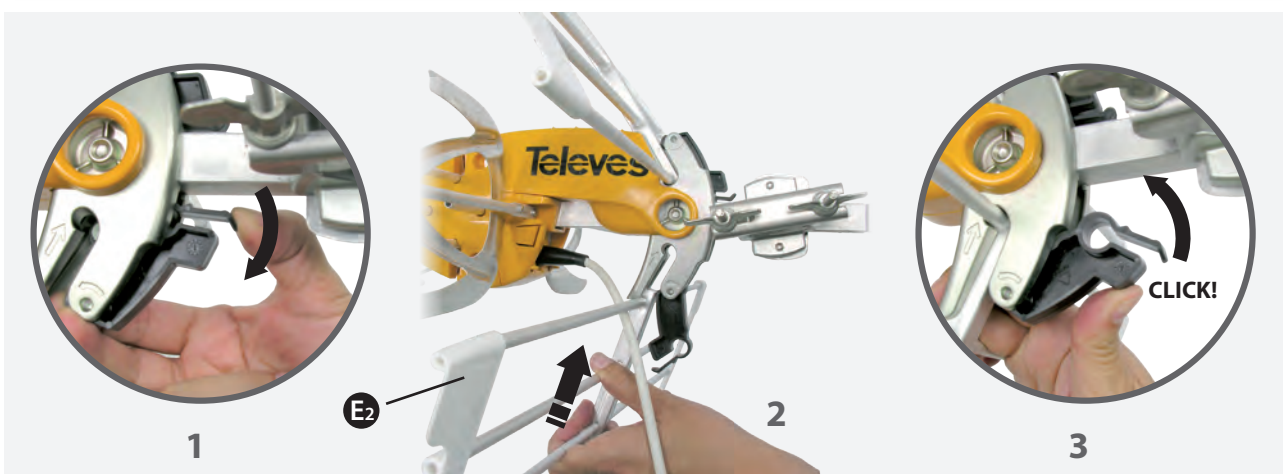
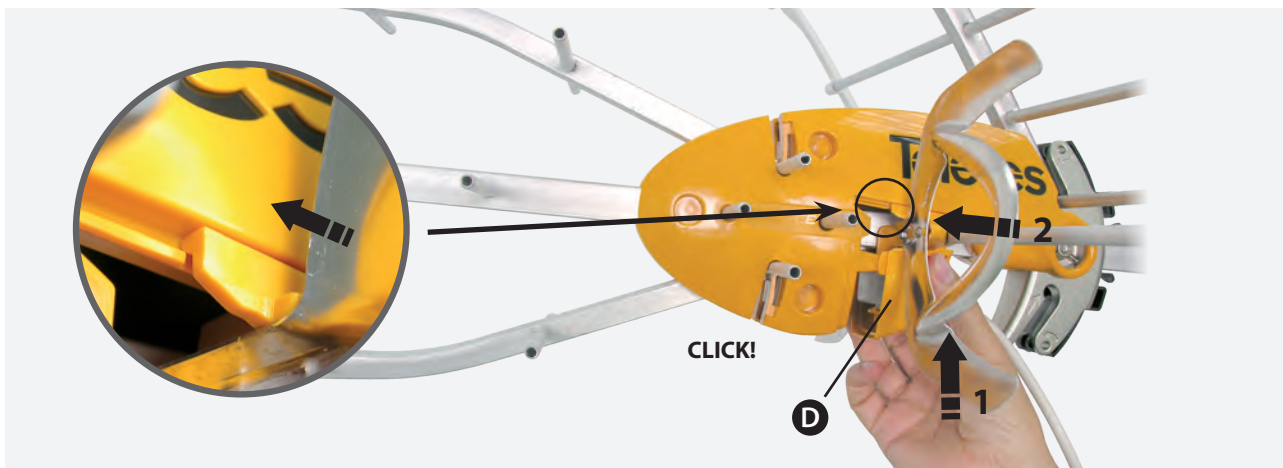

Technical specifications of the intelligent antenna (it must be powered)
Características técnicas de la antena inteligente (debe estar alimentada)

Ref.	Ref.		148820	
Working band	Banda de trabajo	MHz	174 - 216 (CH7 - CH13)	470 - 698 (CH14 - CH51)
Mode	Modo		INTELLIGENT (BOSS ON)	
Gain	Ganancia	dBi	36.5	40
Output level	Nivel de salida		Auto ⁽¹⁾	
Noise figure	Figura de ruido	dB	2.5 (typ)	
Signal level of use (recomm.)	Nivel de señal de uso (recomend.)	dBμV	< 75	
Powering voltage	Tensión de alimentación	V==	12-24	
Consumption	Consumo	mA	40 (max)	
Beamwidth	Ancho de haz	°	30	
F/B ratio	Relación D/A	dB	>20	
Wind load	Carga al viento	N	96 (@ 80 mph) 132 (@ 93 mph)	

⁽¹⁾ - The gain is automatically adjusted according to the output level / La ganancia varía automáticamente en función del nivel de salida.

Application examples / Ejemplos de aplicación

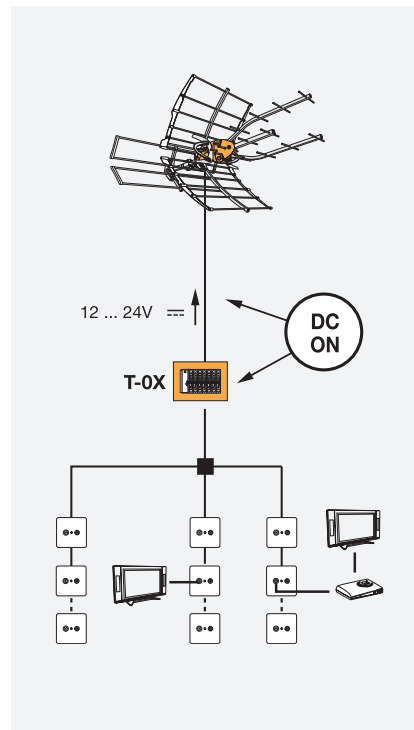
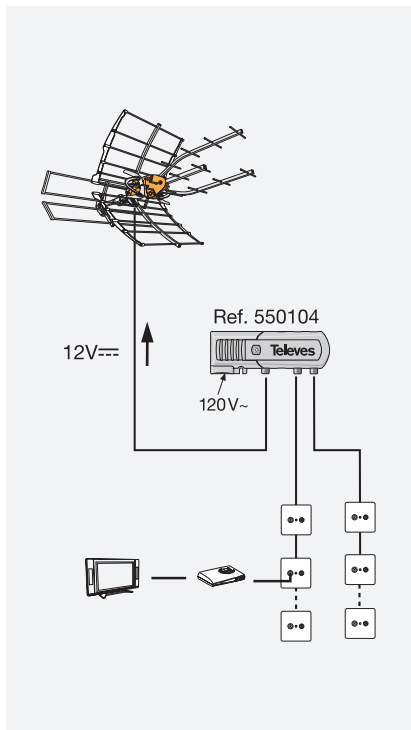

Antenna Selector
 This antenna works in the following zone(s).

See the TV Antenna Selector Map to find the zone in which you live.

Antenna Selector
 This antenna works in the following zone(s).

See the TV Antenna Selector Map to find the zone in which you live.

Safety Instructions:

LIGHTNING PROTECTION

- ◆ If installed outdoors, be sure the antenna system is grounded so as to provide protection against voltage surges and built-up static charges. Section 810 of the National Electrical Code ANSI/NFPA70, or CSA C22.1 sections 10, 16, and 54, of the Canadian Electrical Code, provide information with respect to proper grounding of the mast and supporting structure, grounding of the antenna lead-in wire to an antenna discharge unit, size of grounding conductors, location of antenna-discharge unit, connection to grounding electrodes, and requirements for the grounding electrode (see figure and instructions).
- ◆ Mount the lightning arrester or 75 ohm coaxial grounding block as close as possible to where the 75 ohm coaxial cable download enters the house.
- ◆ The ground wires for both the mast and the download should be copper or aluminium wire, number eight (8) or larger.

- ◆ The download wire from the antenna to the lightning arrester and the mast ground wire should be secured to the house, spaced from four (4) to six (6) feet apart.
- ◆ In the case of a "ground up" antenna installation it may not be necessary to ground the mast if the mast extends four or more feet in the earth. Consult a TV serviceman for the proper depth in your location.

WARNINGS

- ◆ To prevent fire or shock hazard, do not expose the included power supply to rain or moisture.
- ◆ Installation of off-air antennas near power lines is dangerous. For your safety, follow the installation instructions.
- ◆ Any alteration or modification to the product or usage not in accordance with product instructions voids the warranty.

Example of antenna grounding as per National Electrical Code, ANSI/NFPA 70

