

Kit Antenna / Kit Antena

Ref. 148381 (Ant-148320 + PSU-550104 + AA)

DATBOSSMIX LR

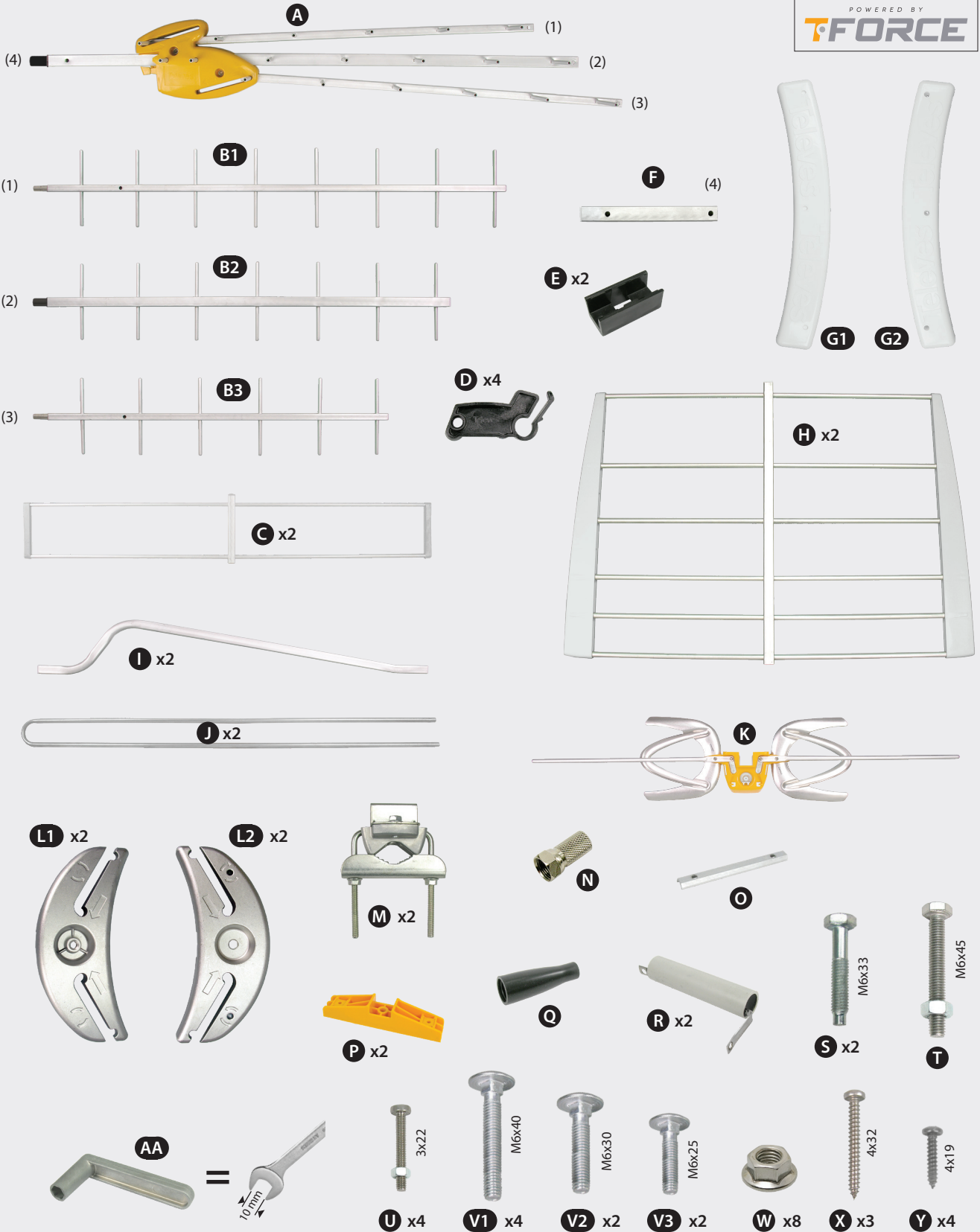

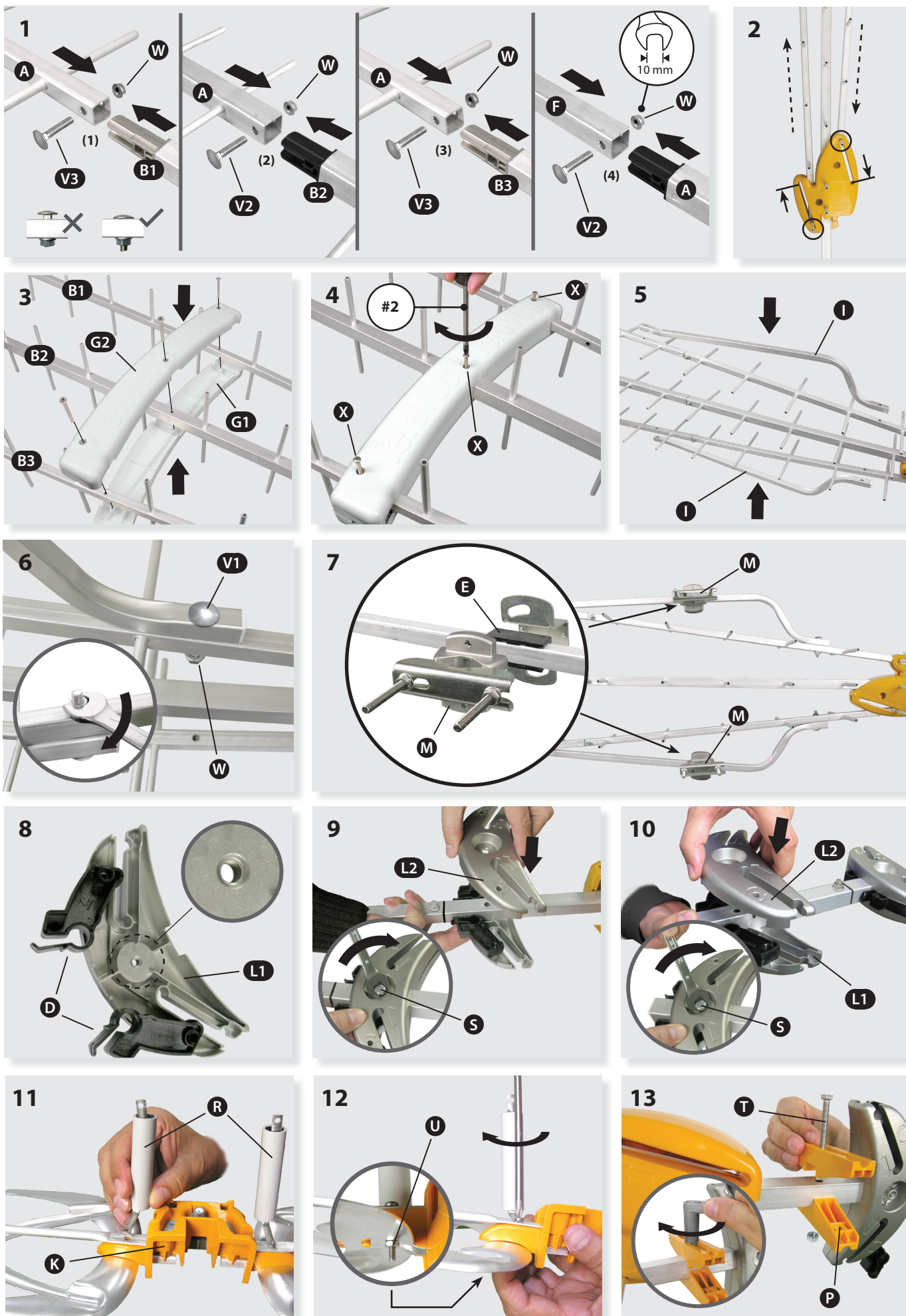

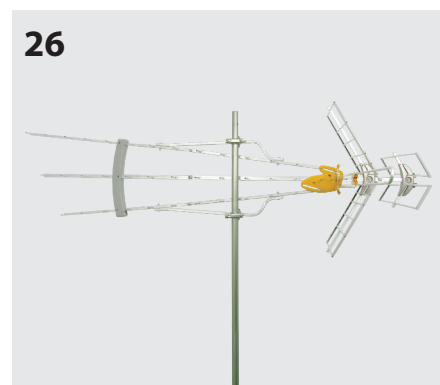
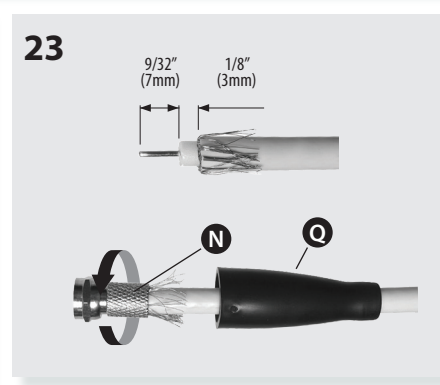
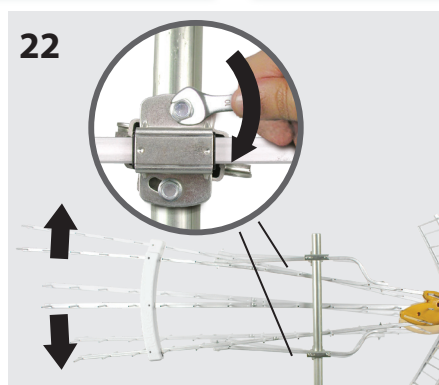
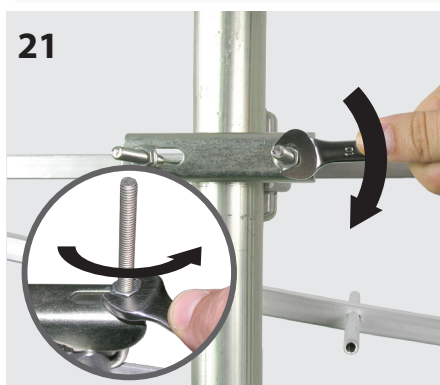
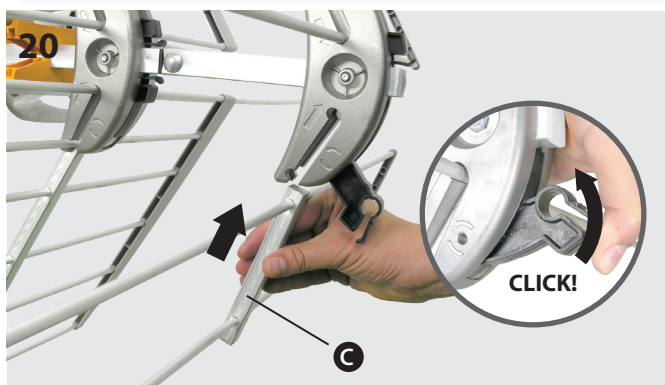
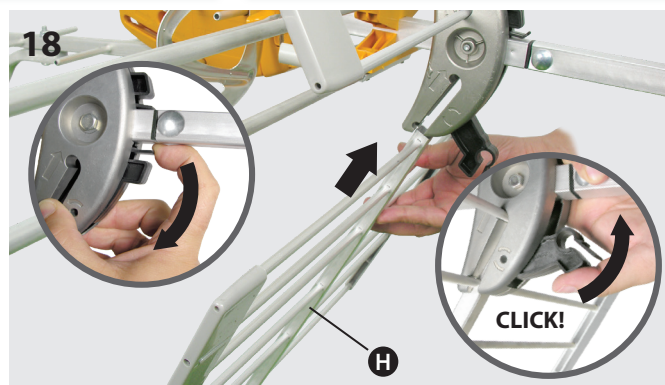
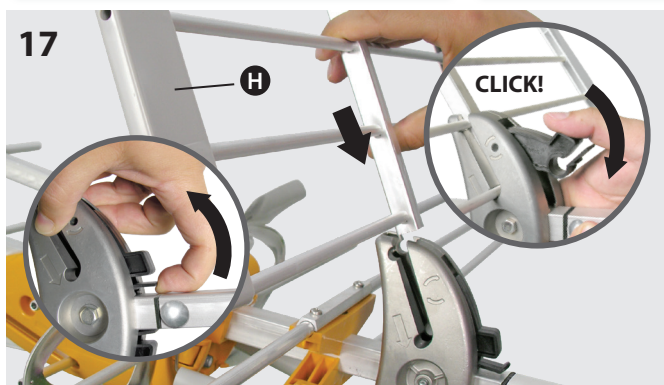
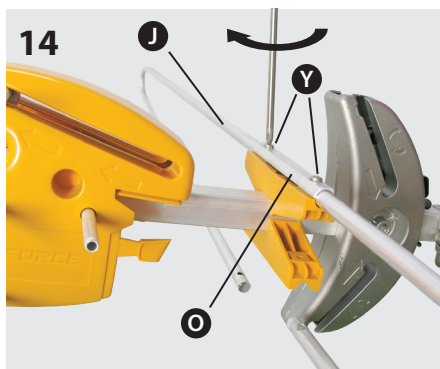

Technical specifications / Características técnicas

Mode		BOSS OFF (Passive)			BOSS ON (Active)			
Operating band	Banda de trabajo	MHz	Low VHF 54 - 88 CH2 - CH6	High VHF 174 - 216 CH7 - CH13	UHF 470 - 698 CH14 - CH51	Low VHF 54 - 88 CH2 - CH6	High VHF 174 - 216 CH7 - CH13	UHF 470 - 698 CH14 - CH51
Gain	Ganancia	dBi	-3	8.5	18	24 max.*	36.5 max.*	46 max.*
Output level	Nivel de salida		----			Auto*		
Noise figure	Figura de ruido	dB	----			3 typ	2 typ	
Power supply	Alimentación	V ---	0			12 - 24		
Consumption	Consumo	mA	----			45 max		
Weight	Peso	g / lb	4,100 / 9.04					
Dimensions	Dimensiones	in / mm	82.8 x 29 x 70 / 2,105 x 736 x 1,780					
Wind load	Carga al viento	N	141 (@ 80 miles/h) 194 (@ 93 miles/h)					

*The gain is automatically adjusted according to the level of output / La ganancia varía automáticamente en función del nivel de salida.

Safety Instructions:

LIGHTNING PROTECTION

- ◆ If installed outdoors, be sure the antenna system is grounded so as to provide protection against voltage surges and built-up static charges. Section 810 of the National Electrical Code ANSI/NFPA70, or CSA C22.1 sections 10, 16, and 54, of the Canadian Electrical Code, provide information with respect to proper grounding of the mast and supporting structure, grounding of the antenna lead-in wire to an antenna discharge unit, size of grounding conductors, location of antenna-discharge unit, connection to grounding electrodes, and requirements for the grounding electrode (see figure and instructions).
- ◆ Mount the lightning arrester or 75 ohm coaxial grounding block as close as possible to where the 75 ohm coaxial cable downlead enters the house.
- ◆ The ground wires for both the mast and the downlead should be copper or aluminum wire, number eight (8) or larger.
- ◆ The downlead wire from the antenna to the lightning arrester and the mast ground wire should be secured to the house, spaced from four (4) to six (6) feet apart.
- ◆ In the case of a "ground up" antenna installation it may not be necessary to ground the mast if the mast extends four or more feet in the earth. Consult a TV serviceman for the proper depth in your location.

WARNINGS

- ◆ To prevent fire or shock hazard, do not expose the included power supply to rain or moisture.
- ◆ Installation of off-air antennas near power lines is dangerous. For your safety, follow the installation instructions.
- ◆ Any alteration or modification to the product or usage not in accordance with product instructions voids the warranty.

Low-VHF

Antenna Selector

This antenna works in the following zone(s).

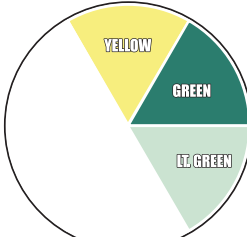

© Consumer Electronics Association

See the TV Antenna Selector Map to find the zone in which you live.

High-VHF

Antenna Selector

This antenna works in the following zone(s).

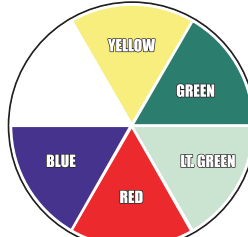

© Consumer Electronics Association

See the TV Antenna Selector Map to find the zone in which you live.

UHF

Antenna Selector

This antenna works in the following zone(s).

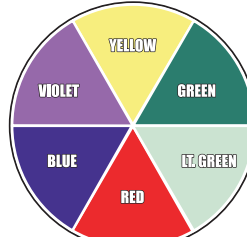

© Consumer Electronics Association

See the TV Antenna Selector Map to find the zone in which you live.

