

USB3.0 HD Video Camera

User Manual

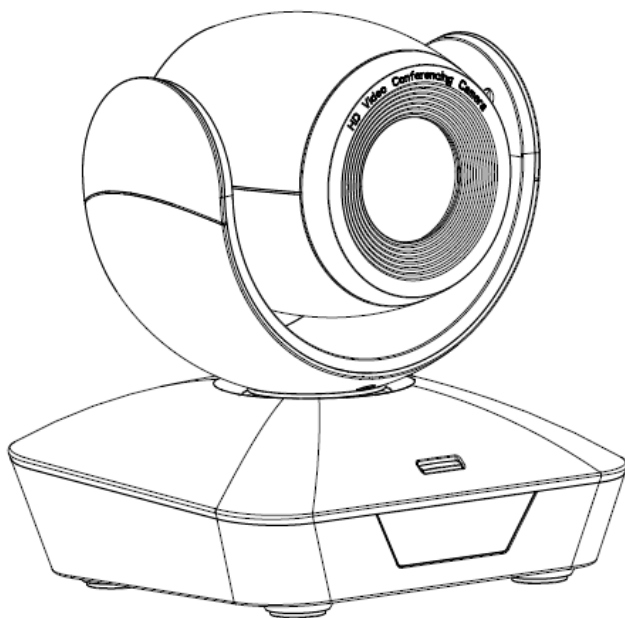

Version V1.0
(English)

CONTENTS

| | |
|---------------------------|----|
| SAFE GUIDES..... | 3 |
| ACCESSORIES..... | 3 |
| QUICK START..... | 4 |
| PRODUCT HIGHLIGHTS..... | 5 |
| PRODUCT SPEC..... | 5 |
| CAMERA INTERFACE..... | 6 |
| CAMERA DIMENSION..... | 6 |
| IR REMOTE CONTROLLER..... | 7 |
| LEARNING FUNCTION..... | 8 |
| VISCA IN(RS232) PORT..... | 9 |
| VISCA PROTPCOL..... | 10 |
| PELCO-D PROTOCOL..... | 16 |
| PELCO-P PROTOCOL..... | 17 |
| OSD MENU..... | 18 |
| UVC CONTROL..... | 21 |

SAFETY GUIDES

- 1.Before operation, please fully read and follow all instructions in the manual. For your safety, always keep this manual with the camera.
- 2.The camera power input range is 100-240VAC(50-60Hz),ensure the power supply input within this rate before powering on.
- 3.The camera power voltage is 12VDC, rated currency is 1.5A. We suggest you use it with the original power supply adapter supplied by the factory.
- 4.Please keep the power cable, video cable and control cable in a safe place. Protect all cables especially the connectors.
- 5.Operational environment: 0°C -50°C, humidity less than 90%.To avoid any danger, do not put anything inside the camera, and keep away from the corrosive liquid.
- 6.Avoid stress, vibration and damp during transportation, storage and installation.
- 7.Do not dismantle the camera housing and cover. For any service, please contact authorized technicians.
- 8.RF cable and control cable should be individually shielded, and cannot be substituted with other cables. Do not direct the camera lens towards strong light, such as the sun or the intensive light.
- 9.Use a dry and soft cloth to clean the camera housing. Applied with neutral cleaning agent when there is need to clean. To avoid damage on the camera lens, never use strong or abrasive cleaning agents on the camera housing.
- 10.Do not move the camera by holding the camera head. To avoid mechanical trouble, do not rotate the camera head by hand.
- 11.Put the camera on fixed and smooth desk or platform, avoid leaned installation.
12. Power Supply Polarity(Drawing)

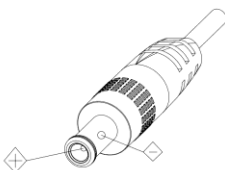

ACCESSORIES

Check all bellow items when open the package:

| | |
|----------------------------|---|
| Camera | 1 |
| Power Adapter | 1 |
| Power Cable | 1 |
| RS232 Control Cable | 1 |
| USB3.0 Cable..... | 1 |
| Remote Controller | 1 |
| User Manual | 1 |
| Double-sided Adhesive..... | 1 |

QUICK START

1. Check all cable connections before power on.

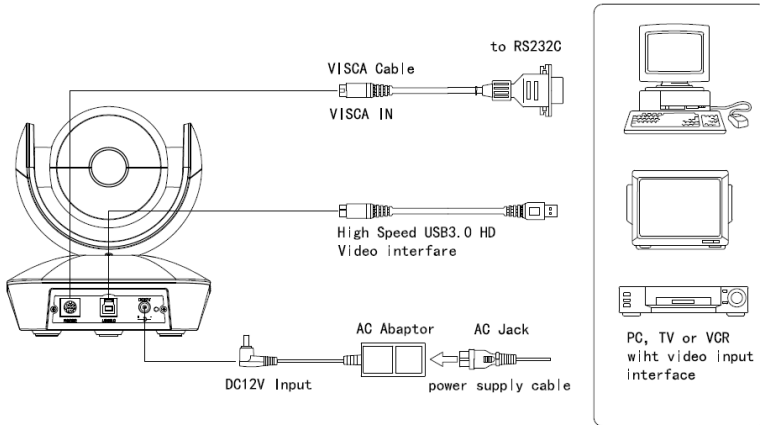

2. DIP Switch Setting (at the bottom of the camera):

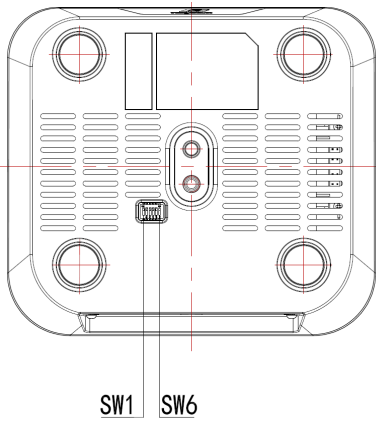

| Function (ARM) | | | |
|----------------|------|------|----------------|
| | SW-1 | SW-2 | Instruction |
| 1 | OFF | OFF | Updating mode |
| 2 | ON | OFF | Debugging mode |
| 3 | OFF | ON | Undefined |
| 4 | ON | ON | Working mode |

| Function (IR CODE TYPE) | | | |
|-------------------------|------|------|------------------------|
| | SW-3 | SW-4 | Instruction |
| 1 | OFF | OFF | Off(Close IR receiver) |
| 2 | ON | OFF | Undefined |
| 3 | OFF | ON | SEJIN 4PPM CODE |
| 4 | ON | ON | NEC CODE(standard) |

| Function (USB) | | | |
|----------------|------|------|---------------|
| | SW-5 | SW-6 | Instruction |
| 1 | OFF | OFF | Undefined |
| 2 | ON | OFF | Working mode |
| 3 | OFF | ON | Updating mode |
| 4 | ON | ON | Undefined |

PRODUCT HIGHLIGHTS

- Smart and fashion design, ideal for cloud-based conferencing
- Adopts advanced DSP, 1/2.8 inch 5MP image sensor, and high quality 10X 62.5degree FOV optical lens, provides fluent and crystal image quality
- Fast switching between different video formats: less than 1 second
- 10X Optical Zoom + 12XDigital Zoom
- Fast and accurate focus performance
- Easy firmware upgrade-(field-upgradable)
- USB3.0 super speed output, USB2.0 compatible
- Effective RS232/485 serial control
- Up to 128 presets
- Compatible with the majority of videoconferencing software (UVC1.5 protocol standard)
- With powerful functional remote controller
- IR transfer/IR pass function: except receiving the camera remote controller signal, the camera can also receive other codec's IR remote control signal, and pass these IR control signal to the codec's IR receiver (via VISCA IN port).
- Multi-language OSD menu: English, Chinese.

PRODUCT SPEC

| | | |
|--------------------|---|---|
| Video Format | USB3.0 | 1080P30/25, 720P60/50/30/25/15, 704*576P30, 640*480P30/25, 352*288P30, 320*240P30, 176*144P30, 160*120P30 |
| | USB2.0 | 720P15, 720*576P30, 704*576P30, 640*480P30/25, 352*288P30, 320*240P30, 176*144P30, 160*120P30 |
| Video Port | USB3.0 | |
| Sensor | 1/2.8 inch high quality 5MP CMOS sensor | |
| Lens | F4.7~47.mm(10X), F1.8 – 14, Field of view: 62.5 °(wide)-6.43 °(tele) | |
| Pan/tilt Rotation | Pan: ±170 °; Tilt: -30 °~+90 °, support up-side down installation | |
| Pan/tilt Speed | Pan: 0.1 °/120 %s; Tilt: 0.1 °/80 %s | |
| Preset | 10 via IR remote setting, 128 via VISCA control, preset accuracy :0.1 ° | |
| Control Port | RS232/RS485 , USB3.0/USB2.0 | |
| Min. Lux | 0.01 Lux | |
| White Balance | Auto/Manual | |
| Focus | Auto/Manual | |
| Iris | Auto/Manual | |
| Shutter | Auto/Manual | |
| WDR | Supported | |
| BLC | Supported | |
| 2D Noise Reduction | Supported | |
| 3D Noise Reduction | Supported | |
| Input Voltage | 12VDC | |
| Dimension | 220mm×173mm×17mm | |
| Net weight | 0.9KGS (2LBS) | |

CAMERA INTERFACE

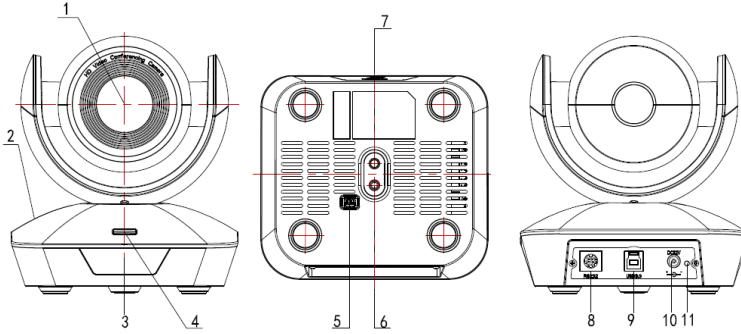

- 1.Camera Lens
- 2.Camera Base
- 3.IR Receiver Panel
- 4.Indicator Light

- 5.Dial Switch
- 6. Tripod Screw Hole
- 7.Installation Hole
- 8.RS232(VISCA IN) Port

- 9.USB3.0 Port
- 10.12VDC Power Input
- 11.Power Indicator light (red)

CAMERA DIMENSION(MM)

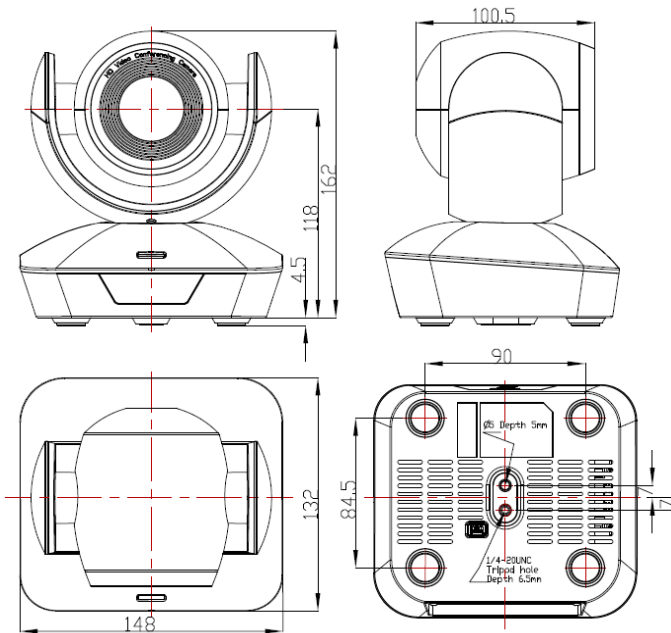

IR REMOTE CONTROLLER



LED Function Instruction

Press any button and shows in red color: Current selection is to control the camera;
Press any button and shows in green color: Current selection is to control the codec;
Press any button and shows in blue color: Current selection is to control the TV;

Power button

Red button: in normal work mode, short press one time, camera will enter standby mode; short press again, the camera will start self-configuration and go to HOME position; it will go to No.0 preset position if that was set;

Green button: Codec power button(need to learn the button coding);

Blue button: TV power button(need to learn the button coding);

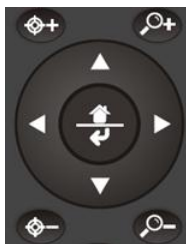

Focus (Left): +/-

Manual focus, only valid under manual focus model;

Zoom (Right): +/-

Control the lens zoom rate;

Navigate : Up/Down/Left/Right

In normal working mode, use navigate key to control pan/tilt;

Confirm/Home button:

In normal working mode, short press to let the camera go back to Home position.

Menu button:

Enter the OSD menu



Number buttons

Set Preset: Long press(3seconds) the number button to save preset;

Clear Preset: +number button to clear the relative preset;

Long press(3seconds) the Clear button to clear all preset;

Run Preset: Short press the number button to run the relative preset.

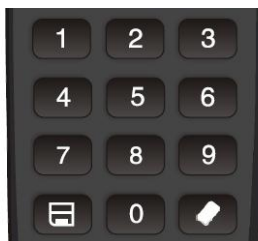

LEARNING FUNCTION:

1. Press the green button, the LED indicator light will show in green color for 1 second, means switch to video terminal/codec control mode;
2. **Single Button Coding:** long press(3seconds) Home +number"1" button simultaneously, the green indicator LED will light, enter button learning mode, press the buttons which need to be learned, LED will start flickering(1HZ), now can start button learning: get the codec remote point to the camera remote's infrared tube(about 10cm distance), then press the button which need to be learned, the LED re-flickering when learning finishes ; press other buttons which also need to be learned; Press the Home+"0" buttons simultaneously to exit and save all remote data.
If the button learning fails, the camera will enter normal working mode after 15seconds, LED will extinguish.
3. **All Button Coding:** long press (3seconds) Home+number"2" button simultaneously, the green indicator LED will start flickering(1HZ), to enter all button learning mode: get codec remote point to the camera remote's infrared tube(about 10cm distance), to start all button coding mode, the LED will extinguish when learning finished.
If the button learning fails, the camera will enter normal working mode after 15seconds, LED will extinguish.
4. **All Button Sending Mode:** long press (3seconds) the Menu+ number "3" button simultaneously, the remote will enter all button sending mode.
5. Similar operation for the TV control mode learning.

VISCA IN (RS232) PORT

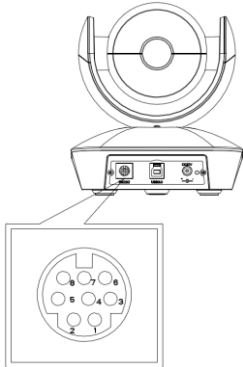

| No. | Function |
|-----|----------|
| 1 | DTR |
| 2 | DSR |
| 3 | TXD |
| 4 | GND |
| 5 | RXD |
| 6 | A |
| 7 | IR OUT |
| 8 | B |

VISCA IN & RS485 Connection

| Camera VISCA IN | | RS485 |
|-----------------|--------|-------|
| 1 | DTR | |
| 2 | DSR | |
| 3 | TXD | |
| 4 | GND | GND |
| 5 | RXD | |
| 6 | A(+) | A(+) |
| 7 | IR OUT | |
| 8 | B(-) | B(-) |

VISCA IN & DB9 Connection

| Camera VISCA IN | | Windows DB-9 | |
|-----------------|--------|--------------|-----|
| 1 | DTR | 6 | DSR |
| 2 | DSR | 4 | DTR |
| 3 | TXD | 2 | RXD |
| 4 | GND | 5 | GND |
| 5 | RXD | 3 | TXD |
| 6 | A(+) | | |
| 7 | IR OUT | | |
| 8 | B(-) | | |

SERIAL PORT CONFIGURATION:

| Parameter | Value | Parameter | Value |
|-----------|-----------------------|------------|-------|
| Baud rate | 2400/4800/9600/115200 | Stop Bit | 1bit |
| Start Bit | 1 bit | Verify Bit | None |
| Date Bit | 8 bit | | |

VISCA PROTOCOL

Part1 Camera Return Command

| Ack/Completion Message | | |
|------------------------|----------------|--|
| | Command Packet | Note |
| ACK | z0 41 FF | Returned when the command is accepted. |
| Completion | z0 51 FF | Returned when the command has been executed. |

z = camera address+8

| Error Messages | | |
|------------------------|----------------|---|
| | Command Packet | Note |
| Syntax Error | z0 60 02 FF | Returned when the command format is different or when a command with illegal command parameters is accepted |
| Command Not Executable | z0 61 41 FF | Returned when a command cannot be executed due to current conditions. For example, when commands controlling the focus manually are received during auto focus. |

Part2 Camera Control Command

| Command | Function | Command Packet | Note |
|---------------|----------------|---|--|
| AddressSet | Broadcast | 88 30 01 FF | Address setting |
| IF_Clear | Broadcast | 88 01 00 01 FF | I/F Clear |
| CAM_Power | On | 8x 01 04 00 02 FF | Power ON/OFF |
| | Off | 8x 01 04 00 03 FF | |
| CAM_Zoom | Stop | 8x 01 04 07 00 FF | p = 0(low)~7(high) pqrs: Zoom Position (0(wide)~ ~0x4000(tele)) |
| | Tele(Standard) | 8x 01 04 07 02 FF | |
| | Wide(Standard) | 8x 01 04 07 03 FF | |
| | Tele(Variable) | 8x 01 04 07 2p FF | |
| | Wide(Variable) | 8x 01 04 07 3p FF | |
| | Direct | 8x 01 04 47 0p 0q 0r 0s FF | |
| CAM_Focus | Stop | 8x 01 04 08 00 FF | pqrs: Focus Position |
| | Far(Standard) | 8x 01 04 08 02 FF | |
| | Near(Standard) | 8x 01 04 08 03 FF | |
| | Direct | 8x 01 04 48 0p 0q 0r 0s FF | |
| | One Push AF | 8x 01 04 18 01 FF | |
| CAM_ZoomFocus | Direct | 8x 01 04 47 0p 0q 0r 0s 0t 0u 0v 0w FF | pqrs: Zoom Position (0(wide)~ 0x4000(tele)) tuvw: Focus Position |
| CAM_WB | Auto | 8x 01 04 35 00 FF | |
| | Indoor | 8x 01 04 35 01 FF | |
| | Outdoor | 8x 01 04 35 02 FF | |

| Command | Function | Command Packet | Note |
|-------------|------------------|----------------------------|-------------------------------|
| | OnePush | 8x 01 04 35 03 FF | |
| | ATW | 8x 01 04 35 04FF | |
| | Manual | 8x 01 04 35 05 FF | |
| | Sodium Lamp | 8x 01 04 35 08 FF | |
| | Fluorescent lamp | 8x 01 04 35 09 FF | |
| CAM_RGain | Reset | 8x 01 04 03 00 FF | Manual Control of R Gain |
| | Up | 8x 01 04 03 02 FF | |
| | Down | 8x 01 04 03 03 FF | |
| | Direct | 8x 01 04 43 00 00 0p 0q FF | pq: R Gain (0~0xFF) |
| CAM_Bgain | Reset | 8x 01 04 04 00 FF | Manual Control of B Gain |
| | Up | 8x 01 04 04 02 FF | |
| | Down | 8x 01 04 04 03 FF | |
| | Direct | 8x 01 04 44 00 00 0p 0q FF | pq: B Gain (0-0xFF) |
| CAM_AE | Full Auto | 8x 01 04 39 00 FF | Automatic Exposure mode |
| | Manual | 8x 01 04 39 03 FF | Manual Control mode |
| | Shutter Priority | 8x 01 04 39 0A FF | Shutter Priority mode |
| | Iris Priority | 8x 01 04 39 0B FF | Iris Priority mode |
| | Bright | 8x 01 04 39 0D FF | Bright mode(Manual control) |
| CAM_Shutter | Reset | 8x 01 04 0A 00 FF | Shutter Setting |
| | Up | 8x 01 04 0A 02 FF | |
| | Down | 8x 01 04 0A 03 FF | |
| | Direct | 8x 01 04 4A 00 00 0p 0q FF | pq: Shutter Position (0~0x15) |
| CAM_Iris | Reset | 8x 01 04 0B 00 FF | Iris Setting |
| | Up | 8x 01 04 0B 02 FF | |
| | Down | 8x 01 04 0B 03 FF | |
| | Direct | 8x 01 04 4B 00 00 0p 0q FF | pq: Iris Position (0~ 0x11) |
| CAM_Gain | Reset | 8x 01 04 0C 00 FF | Gain Setting |
| | Up | 8x 01 04 0C 02 FF | |
| | Down | 8x 01 04 0C 03 FF | |
| | Direct | 8x 01 04 0C 00 00 0p 0q FF | pq: Gain Positon (0~0x0E) |
| CAM_Bright | Reset | 8x 01 04 0D 00 FF | Bright Setting |
| | Up | 8x 01 04 0D 02 FF | |
| | Down | 8x 01 04 0D 03 FF | |
| | Direct | 8x 01 04 4D 00 00 0p 0q FF | pq: Bright I Positon () |

| Command | Function | Command Packet | Note |
|------------------------|--------------|----------------------------|--|
| CAM_WDR | On | 8x 01 04 3D 02 FF | WDR ON/OFF |
| | Off | 8x 01 04 3D 03 FF | |
| | Direct | 8x 01 04 D3 0p FF | pq: WDR Position (1~0x06) |
| CAM_BackLight | On | 8x 01 04 33 02 FF | BackLight On |
| | Off | 8x 01 04 33 03 FF | BackLight Off |
| CAM_Sharpness | Reset | 8x 01 04 02 00 FF | Sharpness Control |
| | Up | 8x 01 04 02 02 FF | |
| | Down | 8x 01 04 02 03 FF | |
| | Direct | 8x 01 04 42 00 00 0p 0q FF | pq: Aperture Gain (0~0x04) |
| CAM_Preset | Reset | 8x 01 04 3F 00 0p FF | p: Preset Number(=0 to 127) Corresponds to 0 to 9 on the Remote Commander |
| | Set | 8x 01 04 3F 01 0p FF | |
| | Recall | 8x 01 04 3F 02 0p FF | |
| CAM_LR_Reverse | On | 8x 01 04 61 02 FF | Image Flip Horizontal ON/OFF |
| | Off | 8x 01 04 61 03 FF | |
| CAM_PictureFlip | On | 8x 01 04 66 02 FF | Image Flip Vertical ON/OFF |
| | Off | 8x 01 04 66 03 FF | |
| CAM_MountMode | UP | 8x 01 04 A4 02 FF | Mount Up |
| | Down | 8x 01 04 A4 03 FF | Mount Down |
| CAM_Saturation | Direct | 8x 01 04 A1 00 00 00 0p FF | (0~0x0E) |
| CAM_2D Noise Reduction | Direct | 8x 01 04 53 0p FF | (0~0x05) |
| CAM_3D Noise Reduction | Direct | 8x 01 04 54 0p FF | (0~0x03) |
| CAM_NewBright | Direct | 81 01 04 A4 00 00 0p 0q FF | (0~0x0F) |
| CAM_Constrast | Direct | 81 01 04 A2 00 00 0p 0q FF | (0~0x0F) |
| CAM_Gamma | Direct | 8x 01 04 5B 0p FF | (0~0x04) |
| FLICK | Off | 81 01 04 23 00 FF | |
| | 50HZ | 81 01 04 23 01 FF | |
| | 60HZ | 81 01 04 23 02 FF | |
| SYS_Menu | Menu On | 8x 01 06 06 02 FF | Turn on the menu |
| | Menu Off | 8x 01 06 06 03 FF | Turn off the menu |
| IR_Transfer | Transfer On | 8x 01 06 1A 02 FF | Receive IR(remote commander) CODE from VISCA communication ON/OFF |
| | Transfer Off | 8x 01 06 1A 03 FF | |
| IR_Receive | On | 8x 01 06 08 02 FF | IR(remote commander)receive ON/OFF |
| | Off | 8x 01 06 08 03 FF | |
| | On/Off | 8x 01 06 08 10 FF | |

| Command | Function | Command Packet | Note |
|------------------|------------------|---|--|
| Pan_tiltDrive | Up | 8x 01 06 01 VV WW 03 01 FF | VV: Pan speed 0x01 (low speed) to 0x18 (high speed) WW: Tilt speed 0x01 (low speed) to 0x14 (high speed) YYYY: Pan Position(TBD) ZZZZ: Tilt Position(TBD) |
| | Down | 8x 01 06 01 VV WW 03 02 FF | |
| | Left | 8x 01 06 01 VV WW 01 03 FF | |
| | Right | 8x 01 06 01 VV WW 02 03 FF | |
| | Upleft | 8x 01 06 01 VV WW 01 01 FF | |
| | Upright | 8x 01 06 01 VV WW 02 01 FF | |
| | DownLeft | 8x 01 06 01 VV WW 01 02 FF | |
| | DownRight | 8x 01 06 01 VV WW 02 02 FF | |
| | Stop | 8x 01 06 01 VV WW 03 03 FF | |
| | AbsolutePosition | 8x 01 06 02 VV WW 0Y 0Y 0Y 0Y 0Z 0Z 0Z 0Z FF | |
| | RelativePosition | 8x 01 06 03 VV WW 0Y 0Y 0Y 0Y 0Z 0Z 0Z 0Z FF | |
| | Home | 8x 01 06 04 FF | |
| | Reset | 8x 01 06 05 FF | |
| Pan-tiltLimitSet | Set | 8x 01 06 07 00 0W 0Y 0Y 0Y 0Y 0Z 0Z 0Z 0Z FF | W:1 UpRight 0:DownLeft YYYY: Pan Limit Position(TBD) ZZZZ: Tilt Limit Position(TBD) |
| | Clear | 8x 01 06 07 01 0W 07 0F 0F 0F 07 0F 0F 0F FF | |

Part3 Inquiry Command

| Command | Command Packet | Return Packet | Note |
|-------------------|----------------|----------------------|----------------------|
| CAM_PowerInq | 8x 09 04 00 FF | y0 50 02 FF | On |
| | | y0 50 03 FF | Off(Standby) |
| CAM_ZoomPosInq | 8x 09 04 47 FF | y0 50 0p 0q 0r 0s FF | pqrs: Zoom Position |
| CAM_FocusModelInq | 8x 09 04 38 FF | y0 50 02 FF | Auto Focus |
| | | y0 50 03 FF | Manual Focus |
| CAM_FocusPosInq | 8x 09 04 48 FF | y0 50 0p 0q 0r 0s FF | pqrs: Focus Position |
| CAM_WBModelInq | 8x 09 04 35 FF | y0 50 00 FF | Auto |
| | | y0 50 01 FF | Indoor mode |
| | | y0 50 02 FF | Outdoor mode |
| | | y0 50 03 FF | OnePush mode |
| | | y0 50 04 FF | ATW |
| | | y0 50 05 FF | Manual |
| CAM_RGainInq | 8x 09 04 43 FF | y0 50 00 00 0p 0q FF | pq: R Gain |
| CAM_BGainInq | 8x 09 04 44 FF | y0 50 00 00 0p 0q FF | pq: B Gain |
| CAM_AEModelInq | 8x 09 04 39 FF | y0 50 00 FF | Full Auto |
| | | y0 50 03 FF | Manual |
| | | y0 50 0A FF | Shutter priority |
| | | y0 50 0B FF | Iris priority |
| | | y0 50 0D FF | Bright |
| CAM_ShutterPosInq | 8x 09 04 4A FF | y0 50 00 00 0p 0q FF | pq: Shutter Position |

| | | | |
|---------------------|----------------|-------------------------------------|--------------------------------------|
| CAM_IrisPosInq | 8x 09 04 4B FF | y0 50 00 00 0p 0q FF | pp: Iris Position |
| CAM_GainPosInq | 8x 09 04 4C FF | y0 50 00 00 0p 0q FF | pp: Gain Position |
| CAM_BrightPosInq | 8x 09 04 4D FF | y0 50 00 00 0p 0q FF | pp: Bright Position |
| CAM_ExpCompModelInq | 8x 09 04 3E FF | y0 50 02 FF | On |
| | | y0 50 03 FF | Off |
| CAM_ExpCompPosInq | 8x 09 04 4E FF | y0 50 00 00 0p 0q FF | pp: ExpComp Position |
| CAM_ApertureInq | 8x 09 04 42 FF | y0 50 00 00 0p 0q FF | pp: Aperture Gain |
| CAM_MemoryInq | 8x 09 04 3F FF | y0 50pp FF | pp: Memory number last operated. |
| SYS_MenuModelInq | 8x 09 06 06 FF | y0 50 02 FF | On |
| | | y0 50 03 FF | Off |
| CAM_LR_ReverseInq | 8x 09 04 61 FF | y0 50 02 FF | On |
| | | y0 50 03 FF | Off |
| CAM_PictureFlipInq | 8x 09 04 66 FF | y0 50 02 FF | On |
| | | y0 50 03 FF | Off |
| CAM_VersionInq | 8x 09 00 02 FF | y0 50 ab cd mn pq rs tu vw FF | |
| IR_Transfer | 8x 09 06 1A FF | y0 50 02 FF | On |
| | | y0 50 03 FF | Off |
| IR_Receive | 8x 09 06 08 FF | y0 50 02 FF | On |
| | | y0 50 03 FF | Off |
| IR_ReceiveReturn | | y0 07 7D 01 04 00 FF | Power ON/OFF |
| | | y0 07 7D 01 04 07 FF | Zoom tele/wide |
| | | y0 07 7D 01 04 38 FF | AF On/Off |
| | | y0 07 7D 01 04 33 FF | CAM_Backlight |
| | | y0 07 7D 01 04 3F FF | CAM_Memory |
| | | y0 07 7D 01 06 01 FF | Pan_tiltDrive |
| Pan-tiltPosInq | 8x 09 06 12 FF | y0 50 0w 0w 0w 0w 0z 0z 0z 0z FF | www: PanPosition zzzz: Tilt Position |

Note: 【x】 means the camera address ; 【y】 = 【x + 8】 .

VISCA PAN TILT ABSOLUTE POSITION VALUE

| Pan Angle | VISCA Value | Tilt Angle | VISCA Value |
|-----------|-------------|------------|-------------|
| -170 | 0xF670 | -30 | 0xFE50 |
| -135 | 0xF868 | 0 | 0x0000 |
| -90 | 0xFAF0 | 30 | 0x01B0 |
| -45 | 0xFD78 | 60 | 0x0360 |
| 0 | 0x0000 | 90 | 0x510 |
| 45 | 0x0288 | | |
| 90 | 0x0510 | | |
| 135 | 0x0798 | | |
| 170 | 0x0990 | | |

VISCA PAN TILT SPEED VALUE

| Pan(degree/second) | | tilt(degree/second) | |
|--------------------|-----|---------------------|-----|
| 0 | 0.3 | 0 | 0.3 |
| 1 | 1 | 1 | 1 |
| 2 | 1.5 | 2 | 1.5 |
| 3 | 2.2 | 3 | 2.2 |
| 4 | 2.4 | 4 | 3.6 |
| 5 | 2.6 | 5 | 4.7 |
| 6 | 2.8 | 6 | 6 |

| | | | |
|----|-----|----|----|
| 7 | 3.0 | 7 | 8 |
| 8 | 3.2 | 8 | 10 |
| 9 | 3.4 | 9 | 12 |
| 10 | 3.8 | 10 | 15 |
| 11 | 4.5 | 11 | 18 |
| 12 | 6 | 12 | 23 |
| 13 | 9 | 13 | 30 |
| 14 | 15 | 14 | 39 |
| 15 | 19 | 15 | 48 |
| 16 | 25 | 16 | 59 |
| 17 | 32 | 17 | 69 |
| 18 | 38 | 18 | 80 |
| 19 | 45 | | |
| 20 | 58 | | |
| 21 | 75 | | |
| 22 | 88 | | |
| 23 | 105 | | |
| 24 | 120 | | |

| | | 60/30mode | 50/25mode | | | |
|---------------|-----|------------------|------------------|------|----|-------|
| Shutter speed | 21 | 1/10000 | 1/10000 | Iris | 0 | close |
| | 20 | 1/6000 | 1/6000 | | 1 | F14 |
| | 19 | 1/4000 | 1/3500 | | 2 | F11 |
| | 18 | 1/3000 | 1/2500 | | 3 | F9.6 |
| | 17 | 1/2000 | 1/1750 | | 4 | F8 |
| | 16 | 1/1500 | 1/1250 | | 5 | F6.8 |
| | 15 | 1/1000 | 1/1000 | | 6 | F5.6 |
| | 14 | 1/725 | 1/600 | | 7 | F4.8 |
| | 13 | 1/500 | 1/425 | | 8 | F4 |
| | 12 | 1/350 | 1/300 | | 9 | F3.4 |
| | 11 | 1/250 | 1/215 | | 10 | F2.8 |
| | 10 | 1/180 | 1/150 | | 11 | F2.4 |
| | 9 | 1/125 | 1/120 | | 12 | F2 |
| | 8 | 1/100 | 1/100 | | 13 | F1.6 |
| | 7 | 1/90 | 1/75 | | | |
| | 6 | 1/60 | 1/50 | | | |
| | 5 | 1/30 | 1/25 | | 16 | f2.0 |
| | 4 | 1/15 | 1/12 | | 17 | f1.8 |
| | 3 | 1/8 | 1/6 | | | |
| | 2 | 1/4 | 1/3 | | | |
| 1 | 1/2 | 1/2 | | | | |
| 0 | 1/1 | 1/1 | | | | |
| Gain | 0 | 0dB | | Gain | 8 | 16dB |
| | 1 | 2dB | | | 9 | 18dB |
| | 2 | 4dB | | | 10 | 20dB |
| | 3 | 6dB | | | 11 | 22dB |
| | 4 | 8dB | | | 12 | 24dB |
| | 5 | 10dB | | | 13 | 26dB |
| | 6 | 12dB | | | 14 | 28dB |
| | 7 | 14dB | | | 15 | 30dB |

PELCO-D PROTOCOL

| Function | Byte1 | Byte2 | Byte3 | Byte4 | Byte5 | Byte6 | Byte7 |
|------------------------------|-------|---------|-------|-------|-----------------|----------------|-------|
| Up | 0xFF | Address | 0x00 | 0x08 | Pan Speed | Tilt Speed | SUM |
| Down | 0xFF | Address | 0x00 | 0x10 | Pan Speed | Tilt Speed | SUM |
| Left | 0xFF | Address | 0x00 | 0x04 | Pan Speed | Tilt Speed | SUM |
| Right | 0xFF | Address | 0x00 | 0x02 | Pan Speed | Tilt Speed | SUM |
| Upleft | 0xFF | Address | 0x00 | 0x0C | Pan Speed | Tilt Speed | SUM |
| Upright | 0xFF | Address | 0x00 | 0x0A | Pan Speed | Tilt Speed | SUM |
| DownLeft | 0xFF | Address | 0x00 | 0x14 | Pan Speed | Tilt Speed | SUM |
| DownRight | 0xFF | Address | 0x00 | 0x12 | Pan Speed | Tilt Speed | SUM |
| Zoom In | 0xFF | Address | 0x00 | 0x20 | 0x00 | 0x00 | SUM |
| Zoom Out | 0xFF | Address | 0x00 | 0x40 | 0x00 | 0x00 | SUM |
| Focus Far | 0xFF | Address | 0x00 | 0x80 | 0x00 | 0x00 | SUM |
| Focus Near | 0xFF | Address | 0x01 | 0x00 | 0x00 | 0x00 | SUM |
| Set Preset | 0xFF | Address | 0x00 | 0x03 | 0x00 | Preset ID | SUM |
| Clear Preset | 0xFF | Address | 0x00 | 0x05 | 0x00 | Preset ID | SUM |
| Call Preset | 0xFF | Address | 0x00 | 0x07 | 0x00 | Preset ID | SUM |
| Query Pan Position | 0xFF | Address | 0x00 | 0x51 | 0x00 | 0x00 | SUM |
| Query Pan Position Response | 0xFF | Address | 0x00 | 0x59 | Value High Byte | Value Low Byte | SUM |
| Query Tilt Position | 0xFF | Address | 0x00 | 0x53 | 0x00 | 0x00 | SUM |
| Query Tilt Position Response | 0xFF | Address | 0x00 | 0x5B | Value High Byte | Value Low Byte | SUM |
| Query Zoom Position | 0xFF | Address | 0x00 | 0x55 | 0x00 | 0x00 | SUM |
| Query Zoom Position Response | 0xFF | Address | 0x00 | 0x5D | Value High Byte | Value Low Byte | SUM |

PELCO-P PROTOCOL

| Function | Byte1 | Byte2 | Byte3 | Byte4 | Byte5 | Byte6 | Byte7 | Byte8 |
|------------------------------|-------|---------|-------|-------|-----------------|----------------|-------|-------|
| Up | 0xA0 | Address | 0x00 | 0x08 | Pan Speed | Tilt Speed | 0xAF | XOR |
| Down | 0xA0 | Address | 0x00 | 0x10 | Pan Speed | Tilt Speed | 0xAF | XOR |
| Left | 0xA0 | Address | 0x00 | 0x04 | Pan Speed | Tilt Speed | 0xAF | XOR |
| Right | 0xA0 | Address | 0x00 | 0x02 | Pan Speed | Tilt Speed | 0xAF | XOR |
| Upleft | 0xA0 | Address | 0x00 | 0x0C | Pan Speed | Tilt Speed | 0xAF | XOR |
| Upright | 0xA0 | Address | 0x00 | 0x0A | Pan Speed | Tilt Speed | 0xAF | XOR |
| DownLeft | 0xA0 | Address | 0x00 | 0x14 | Pan Speed | Tilt Speed | 0xAF | XOR |
| DownRight | 0xA0 | Address | 0x00 | 0x12 | Pan Speed | Tilt Speed | 0xAF | XOR |
| Zoom In | 0xA0 | Address | 0x00 | 0x20 | 0x00 | 0x00 | 0xAF | XOR |
| Zoom Out | 0xA0 | Address | 0x00 | 0x40 | 0x00 | 0x00 | 0xAF | XOR |
| Focus Far | 0xA0 | Address | 0x00 | 0x80 | 0x00 | 0x00 | 0xAF | XOR |
| Focus Near | 0xA0 | Address | 0x01 | 0x00 | 0x00 | 0x00 | 0xAF | XOR |
| Set Preset | 0xA0 | Address | 0x00 | 0x03 | 0x00 | Preset ID | 0xAF | XOR |
| Clear Preset | 0xA0 | Address | 0x00 | 0x05 | 0x00 | Preset ID | 0xAF | XOR |
| Call Preset | 0xA0 | Address | 0x00 | 0x07 | 0x00 | Preset ID | 0xAF | XOR |
| Query Pan Position | 0xA0 | Address | 0x00 | 0x51 | 0x00 | 0x00 | 0xAF | XOR |
| Query Pan Position Response | 0xA0 | Address | 0x00 | 0x59 | Value High Byte | Value Low Byte | 0xAF | XOR |
| Query Tilt Position | 0xA0 | Address | 0x00 | 0x53 | 0x00 | 0x00 | 0xAF | XOR |
| Query Tilt Position Response | 0xA0 | Address | 0x00 | 0x5B | Value High Byte | Value Low Byte | 0xAF | XOR |
| Query Zoom Position | 0xA0 | Address | 0x00 | 0x55 | 0x00 | 0x00 | 0xAF | XOR |
| Query Zoom Position Response | 0xA0 | Address | 0x00 | 0x5D | Value High Byte | Value Low Byte | 0xAF | XOR |

OSD MENU

1. under working mode, press the menu button  on the IR remote, to enter the OSD menu ;
2. Use the navigate button to select the main menu. Once been selected, the main menu will change to grey color background, and the right side will show all parameters under this sub menu :

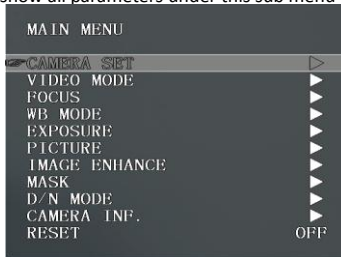

3. Press the right navigate button to enter sub menu, use up and down navigate button to select parameter;
4. Press the menu button  again to return to previous menu; Press it continuously to exit the OSD menu. Before exiting, will show up a window to remind whether need to save all settings (use left and right button to set)



5.OSD Menu List& Defaulted Setting

| | | | | |
|------------|------------|-------------------------|-----------------|-------|
| CAMERA SET | LANGUAGE | ENGLISH/CHINESE | | |
| | PROTOCOL | VISCA/PELCO-P/PELCO-D | | VISCA |
| | ADDRESS | VISCA:1~7 | PELCO-P/D:0~255 | 1 |
| | BAUD RATE | 2400/9600/115200 | | 9600 |
| | PARITY BIT | NONE | | |
| | RETURN | Return to previous menu | | |

| | | | |
|------------|---|-------------------------|--|
| VIDEO MODE | It will cause video freeze if switch video mode via OSD menu; Only recommend to change video mode via UVC control. | | |
| | RETURN | Return to previous menu | |

| | | | |
|-------|-------------|---|------|
| FOCUS | FOCUS MODE | AUTO/MANU/PUSH | AUTO |
| | SENSITIVITY | Focus Sensitivity setting: LOW/MID/HIGH | MID |

| | | | |
|--|----------------|---|------|
| | FOCUS LIMIT | The target distance: 1.5M/2M/3M/6M/10M | 1.5M |
| | D_ZOOM | Digital Zoom: OFF/ON | OFF |
| | ZOOM SPEED | Set zoom speed level:0~7 | 7 |
| | LENS INIT | Lens focus parameter frequency setting, choose EXE to start the lens focus reset | OFF |
| | DIS ZOOM RATIO | Display zoom value during zooming control | OFF |
| | RETURN | Return to previous menu | |

| | | | |
|---------|---------|---------------------------------|-----|
| WB MODE | WB MODE | Set White Balance mode | ATW |
| | B_GAIN | Set blue gain under manual mode | 52 |
| | R_GAIN | Set red gain under manual mode | 58 |
| | RETURN | Return to previous menu | |

| | | | |
|----------|-----------|--|-------|
| EXPOSURE | EXP MODE | AUTO、MANUAL、BRIGHT、SHUTTER、IRIS | AUTO |
| | SHUT TIME | Set shutter speed: 1/8~1/10000 Only available under MANU or SHUT mode | 1/100 |
| | IRIS | Set iris value: 0~13, only available under MANU or IRIS mode | 10 |
| | GAIN | Set gain value: 0~15, only available under MANU mode | 0 |
| | BRIGHT | Set bright value: 0~27 , only available under MANU mode | 11 |
| | SLOW SHUT | Slow shutter set: OFF/ON | OFF |
| | FLICK | 50HZ/60HZ/OFF | 50Hz |
| | RETURN | Return to previous menu | |

| | | | |
|---------|------------|--|-----|
| PICTURE | BRIGHTNESS | Set brightness value: 0~15 | 6 |
| | SHARPNESS | Set sharpness value: 0~15 | 3 |
| | CONSTRAS | Set contrast value: 0~15 | 7 |
| | SATURATION | Set saturation value: 0~15, the higher value, the stronger color | 8 |
| | MIRROR | Left/right flip: ON/OFF | OFF |
| | PIC FLIP | Up/down flip: ON/OFF | OFF |
| | FREEZE | ON/OFF | OFF |
| | DEFOG | Set image permeability | 2 |
| | RETURN | Return to previous menu | |

| | | | |
|------------------|-----------|-----------------------------|------|
| IMAGE ENHANCE | 2D NR | ON/OFF | OFF |
| | 3D NR | OFF/AUTO/1~4 | AUTO |
| | D_WDR | Set dynamic level : OFF/1~6 | 1 |
| | GAMMA | Set gamma: 0~4 | 0 |
| | BACKLIGHT | ON/OFF | OFF |
| | HIGHLIGHT | ON/OFF | OFF |
| | RETURN | Return to previous menu | |

| | | | |
|------|-----------------|--|-------|
| MASK | MASK SWITCH | Privacy zone function: ON/OFF | OFF |
| | COLOUR | Set mask zone color: WHITE/YELLOW/GRAY/GREEN/VIOLET/RED | WHITE |
| | INDEX | Set mask zone number: 1~8 | 1 |
| | INDEX SWITCH | Set index zone: ON/OFF | OFF |
| | ROW START | Set current mask zone's row start position | 0 |
| | ROW END | Set current mask zone's row end position | 479 |
| | LINE START | Set current mask zone's line start position | 0 |
| | LINE END | Set current mask zone's line end position | 539 |
| | RETURN | Return to previous menu | |

| | | | |
|-------------|--------------|--|-----|
| D/N MODE | D/N MODE | Set D/N mode: DAY/NIGHT/AUTO | DAY |
| | DAY TO NIGHT | Set day to night brightness threshold value: 15~200 | 48 |
| | NIGHT TO DAY | Set night to day brightness threshold value: 5~190 | 8 |
| | SWITCH DELAY | Set switch delay between different mode, to avoid repeat switching under AUTO mode: 1~60s | 5s |
| | GAIN LIMIT | Gain limit under low light:2/4/6/8/11/16/32/64/128/256/320/511 | 511 |
| | RETURN | Return to previous menu | |

| | | |
|----------------|--------------|---------------------------------------|
| CAMERA INF. | IMAGE VER. | Image firmware version |
| | IMAGE DATE | Image firmware release date: YY/MM/DD |
| | CONTROL VER. | Control firmware version |

| | | |
|--|--------------|---|
| | CONTROL DATE | Control firmware release date: YY/MM/DD |
| | BAUDRATE | Current baud rate value |
| | PARITY BIT | Current control protocol parity bit value |
| | RETURN | Return to previous menu |

| | |
|-------|--|
| RESET | REEST to defaulted value (except the Language): ON/OFF |
|-------|--|

UVC CONTROL

1. Only run the client software after the USB3.0 camera has completed self-configuration(the IR indicator in blue color and will not flash); otherwise may cause black video issue.
2. Make sure the USB3.0 camera is recognized by the PC Device Manager.
3. Make sure the interval of video format switching more than 1 seconds, otherwise black video maybe caused.
4. Make sure the interval of control command sending from the server(via USB) to the camera no less than 250ms.
5. Support standard UVC interface.

| UVC Property | Corresponded VISCA Command |
|--|---|
| PU_BACKLIGHT_COMPENSATION_CONTROL | 8x 01 04 33 02 FF |
| CY_FX_UVC_PU_BRIGHTNESS_CONTROL | 8x 01 04 A4 00 00 0p 0q FF |
| CY_FX_UVC_PU_CONTRAST_CONTROL | 8x 01 04 A2 00 00 0p 0q FF |
| CY_FX_UVC_PU_SATURATION_CONTROL | 8x 01 04 A1 00 00 0p 0q FF |
| CY_FX_UVC_PU_SHARPNESS_CONTROL | 8x 01 04 42 00 00 0p 0q FF |
| CY_FX_UVC_PU_GAMMA_CONTROL | 8x 01 04 5B 0p FF |
| CY_FX_UVC_PU_WHITE_BALANCE_TEMPERATURE_CONTROL | 8x 01 04 35 0p FF |
| CY_FX_UVC_PU_BACKLIGHT_COMPENSATION_CONTROL | 8x 01 04 33 0p FF |
| CY_FX_UVC_PU_GAIN_CONTROL | 8x 01 04 49 00 00 0p 0q FF |
| CY_FX_UVC_PU_POWER_LINE_FREQUENCY_CONTROL | 8x 01 04 AA 0p FF |
| PU_GAIN_CONTROL | 8x 01 04 49 00 00 00 0p FF |
| CT_ZOOM_ABSOLUTE_CONTROL | 8x 01 04 47 0p 0q 0r 0s FF |
| CT_PANTILT_ABSOLUTE_CONTROL | 8x 01 06 02 VV WW 0Y 0Y 0Y 0Y 0Z 0Z 0Z 0Z FF |
| CT_PANTILT_RELATIVE_CONTROL | 8x 01 06 01 pp qq rr ss FF |
| CT_ZOOM_RELATIVE_CONTROL | 8x 01 04 07 pp FF |

