



TSX Series high-performance undercounter refrigerators

The only undercounter lab-grade refrigerator with redundant cooling

- Low energy usage
- Low noise
- High storage capacity
- Universal voltage



Introducing the Thermo Scientific™ TSX505

Powered by V-Drive featuring STeM Technology

- Redundant cooling technology protects your storage while delivering 37% less energy, 20X less noise and twice the storage capacity*
- Variable speed control using thermoelectric devices in place of compressors, provides ideal conditions for the most demanding applications
- Universal voltage (100-240v, 50/60hz) allows placement throughout the facility and globally just by connecting the region specific power cord.



Designed for the following industries



Biological



Diagnostic kits & reagents



Molecular biology



Vaccines & pharmacies



Clinical applications



Industrial testing

Air and glycol temperature display

Electronic lock

Bright, easy-to-adjust interior LED lighting

ADA compliant, ergonomic handle with reversible doors fits any workspace configuration

Choice of transparent glass or solid door

Datalogging with USB download functionality

Audible & visual alarms
(power fail, high temp, low temp, low battery, memory full, door ajar)

Convenient, adjustable shelves
(rolling wire baskets available as customer installed accessory)

1" rear access port



*Internal data based on comparisons to Thermo Scientific model

How the TSX505 works

Compressor-free V-drive featuring STeM (synchronized temperature management)

- Dual refrigeration system combines the benefits of cold wall and fan-assisted recovery
- Actively monitors the cabinet to maintain the desired temperature conditions
- Constant monitoring and adjustment during periods of door openings keeps temperatures stable without temperature fluctuation found in models with compressors that cycle on/off
- This tight internal air circulation eliminates the risk of freezing which can ruin materials like vaccines

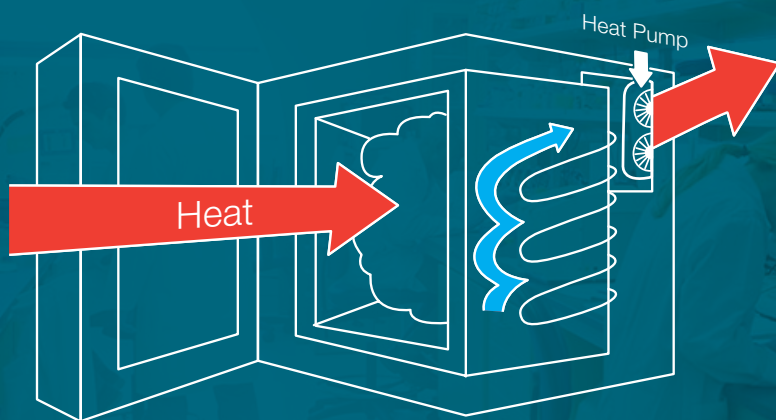

The TSX505's refrigerant loop absorbs and transfers heat energy from the outside into a heat pump in the back of the refrigerator. There, heat rejection coils transfer heat energy from the heat pump back into the ambient environment.

System Comparison Chart

In the chart, the gray line represents the additive effect of using cold wall (blue line) and forced air (orange line), with the benefit that if one of those systems should experience an issue, you know the other system can keep the unit going until service arrives.

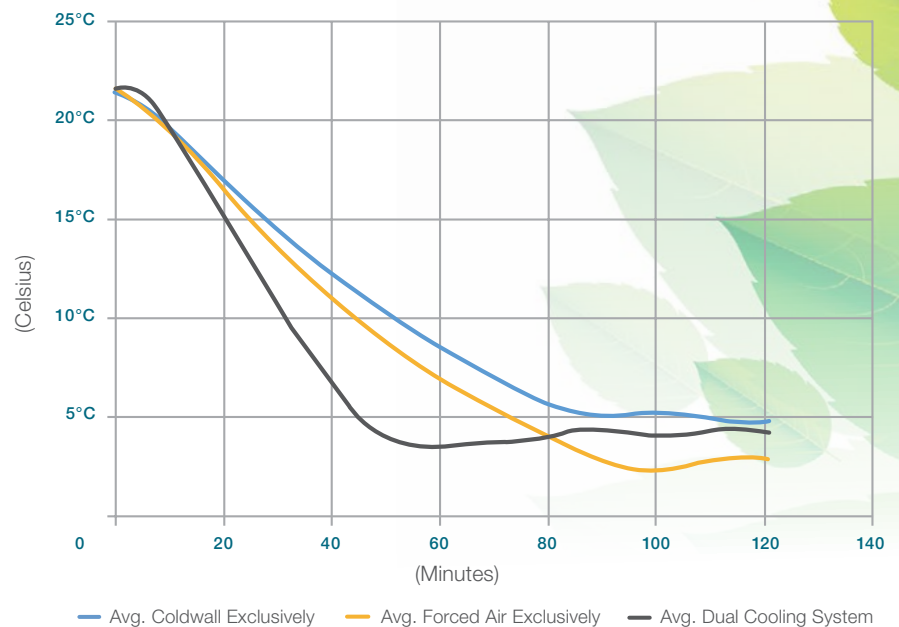

Designed to save energy, reduce noise and meet sustainability protocols

As shown, the TSX505 uses up to 37% less energy with an annual cost reduction of 39%*

Energy Usage

Refrigerator Model	Annual Power Usage (kW)	Annual Run Time (hours)	Annual Energy Usage (kWh)	Additional Energy Used
TSX505	0.11	24	2.7	0%
REL404	0.18	24	4.30	37.2%

Annual Cost to Run

Refrigerator Mode	Cycle/Day	Usage Hours/Day	Usage Hours/Year	Energy Cost (\$/kWh)**	Annual Cost	Additional Cost
TSX505	1	24	8,760	\$0.1019	\$98.19	0%
REL404	1	24	8,760	\$0.1019	\$160.68	30%

The sound of quiet

Whisper-quiet operation is the unseen feature of the TSX505. As shown, the 35 dBA sound output is less than an average library, enabling the refrigerator to reside comfortably in work station areas.

The SNAP/F-Gas compliant choice

The TSX505 is designed to meet the standards established by the U.S. Environmental Protection Agency's Significant New Alternatives Policy (SNAP) program and the European Union's F-Gas Regulation (517/2014). SNAP evaluates refrigerants that are potentially harmful to the environment. The TSX505 has been designed with refrigerants that are in compliance with SNAP.

*Internal data based on comparisons to Thermo Scientific model REL404A.

**https://www.eia.gov/electricity/monthly/epm_table_grapher.cfm?t=epmt_5_6_a. Use data from the most current month reported and use the energy rate for the "US Total" in the "Commercial" sector.

Decibel scale of common sounds

Noise source	Decibel level (dBA)
Freeway traffic, vacuum cleaner	70
Conversation in restaurant, office, background music	60
Library	40
TSX Series undercounter refrigerator	35[†]
Quiet rural area	30
Rustling leaves	20
Breathing	10

[†] Steady state 35 dBA; start-up 42 dBA

Designed to hold more within a smaller footprint

As shown in these two side views, the TSX505 does not include internal protrusions such as overhead fans. This allows you to store more inside its interior. Also, with the V-drive and STeM cooling, temperatures are consistent at all shelf levels, making the TSX505 a smart choice for vaccines, reagents, media and other sensitive material.

TSX Series undercounter

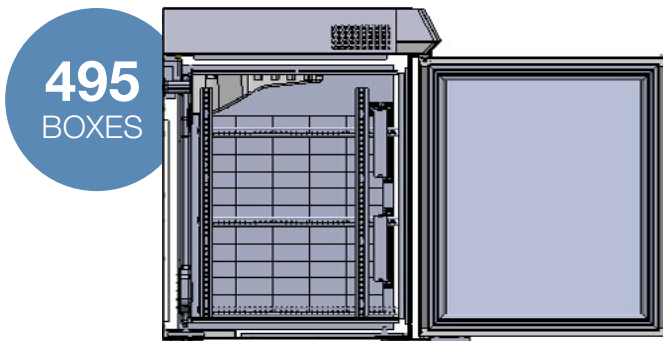

- 45 boxes per level (9x5 pattern)
- 225 boxes per shelf (5 levels per shelf, 2 shelves per unit)
- +45 boxes (1 additional level above top shelf)

Total number of vaccine boxes: 495 boxes (225 + 225 + 45)**

*Thermo Scientific Revco, model REL404
**MMR vaccine box: 3.5"W x 1.75"H x 1.625"D

Alternative model*

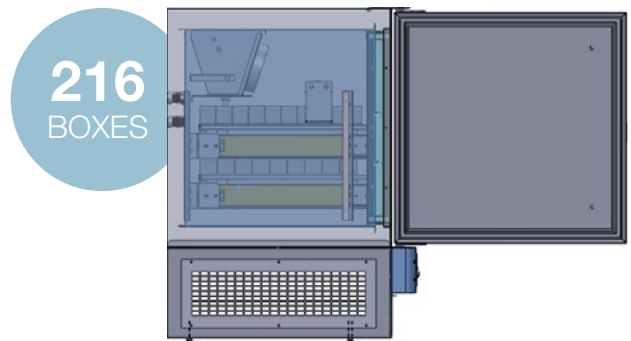

- 36 boxes per level (9x4 pattern)
- 108 boxes per shelf (3 levels per shelf, 2 shelves per unit)

Total number of vaccine boxes: 216 boxes (108 + 108)

Easy to operate user interface

- Password protected
- Icon based
- Adjustable lighting
- Built-in datalogging
- USB port
- Ergonomic tilted design to help prevent neck strain
- Electronic lock is standard

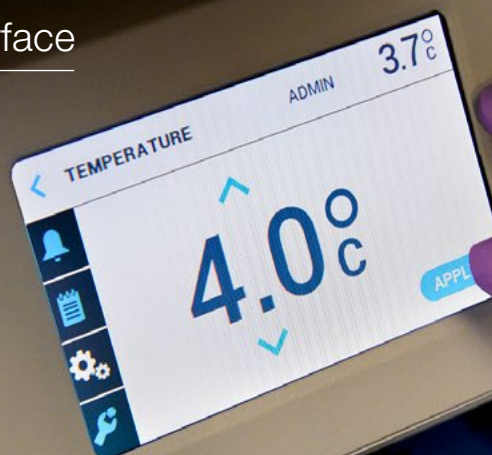

Specifications and ordering information

TSX Series high-performance undercounter refrigerator

Model No.	Doors	Settable Range	Energy Consumption	Capacity cu. ft. (liters)	Electrical	Plug Type	Shelves	Defrost	Sound Level	Certifications	Interior Dimensions: (D x W x H)	Exterior Dimensions: (D x W x H)	Shipping Weight lbs. (kg)
TSX505SA	1, Solid	+3°C to +7°C	1.7 kWh/day	156 Liters / 5.5 Cubic Feet	100 - 240v, 50/60hz*	NEMA 5-15	3	Auto	35 dBa / 3	UL, CE, REACH, RoHS	20.5 x 19.5 x 23 in. (520 x 495 x 584 mm)	26 x 23.6 x 31.8 in. (660.4 x 599.4 x 807.7 mm)	155 (71)
TSX505GA	1, Glass		2.4 kWh/day										147 (66.7)

*For alternate power cords, review accessory list below.

Customer installed accessories

For use with refrigerator size	5.5 cu. ft. (156L)
Description	Cat. No.
Rolling Wire Basket	WB05
Additional wire shelf	WS05
Set of casters with mounting hardware	CS05
Power Cord 115V	100056H01
Power Cord, D NEMA 6-15P 230V	100091H01
Power Cord, V EU Schuko 230V	100089H01
Power Cord, C China 220V/50Hz	100092H01
Power Cord, W UK Type G-10A 23	100090H01



Thermo Scientific™ Snappies™ Breast Milk Containers



Thermo Scientific™ Nalgene™ Bottles and Containers



Media and Reagents

Visit thermofisher.com for accessories, wireless monitoring, consumables, media, reagents and more.