

# **Thermo Scientific ThermoFlex™ Recirculating Chillers (Deluxe Controller)**

Thermo Scientific Manual P/N U00939  
Rev. 03/29/2021



**Multilingual Quick  
Start Guides**

**Multilingual Essential  
Safety Instructions**

**Installation**

**Operation**

**Preventive  
Maintenance**

**Troubleshooting**

Visit our Web site at:

<http://www.thermofisher.com/tc>  
Product Service Information, Applications  
Notes, SDS Forms, e-mail.

Voice Info: (800) 258-0830



**Thermo Scientific**  
**ThermoFlex™**  
**Recirculating Chillers**  
**(Deluxe Controller)**

Thermo Scientific Manual P/N U00939  
Rev. 03/29/2021



Label 1

---

**Multilingual Quick Start  
Guides**

**Multilingual Essential  
Safety Instructions**

**Installation**

**Operation**

**Preventive  
Maintenance**

**Troubleshooting**

Label 2

---

Visit our Web site at:

**<http://www.thermofisher.com/tc>**  
Product Service Information, Applications  
Notes, SDS Forms, e-mail.

Voice Info: (800) 258-0830

## **Thermo Fisher Scientific**

25 Nimble Hill Road  
Newington, NH 03801  
Tel : (800) 258-0830 or  
(603) 436-9444  
Fax : (603) 436-8411  
[www.thermofisher.com/tc](http://www.thermofisher.com/tc)

## **Sales, Service, and Customer Support**

25 Nimble Hill Road  
Newington, NH 03801  
Tel: (800) 258-0830  
Sales: 8:00 am to 5:00 pm  
Service and Support: 8:00 am to 6:00 pm Monday  
through Friday (Eastern Time)  
Fax: (603) 436-8411  
[service.tc.us@thermofisher.com](mailto:service.tc.us@thermofisher.com)

Dieselstrasse 4  
D-76227 Karlsruhe, Germany  
Tel : +49 (0) 721 4094 444  
Fax : +49 (0) 721 4094 300  
[info.tc.de@thermofisher.com](mailto:info.tc.de@thermofisher.com)

Building 6, No. 27  
Xin Jinqiao Rd., Shanghai 201206  
Tel : +86(21) 68654588  
Fax : +86(21) 64457830  
[info.china@thermofisher.com](mailto:info.china@thermofisher.com)

## **Statement of Copyright**

Copyright © 2021 Thermo Fisher Scientific. All rights reserved.

This manual is copyrighted by Thermo Fisher Scientific.

Users are forbidden to reproduce, republish, redistribute, or resell any materials from this manual in either machine-readable form or any other form.

# Contents

## Quick Start

<b>Preface</b> .....	<b>i</b>
Compliance .....	i
WEEE .....	i
After-Sale Support .....	ii
Feedback .....	ii
Warranty .....	ii
Unpacking .....	ii
<b>Section 1 Safety</b> .....	<b>1-1</b>
Warnings .....	1-1
<b>Section 2 General Information</b> .....	<b>2-1</b>
Description .....	2-1
Specifications .....	2-1
<b>Section 3 Installation</b> .....	<b>3-1</b>
Site Requirements .....	3-1
Electrical Requirements .....	3-3
Hard Wire Installation .....	3-11
Plumbing Requirements .....	3-12
Process Fluid Requirements .....	3-14
Compatibility with Approved Fluids .....	3-15
Additional Fluid Information .....	3-17
Process Water Quality - Standards and Recommendations .....	3-17
Facility Water Requirements - Standards and Recommendations .....	3-18
Facility Water Requirements (water-cooled chillers) .....	3-19
Fluid Filter Bag .....	3-22
Priming .....	3-22
Initial Filling Requirements .....	3-23
Fluid Top Off .....	3-24
<b>Section 4 Operation</b> .....	<b>4-1</b>
Deluxe Controller .....	4-1
Setup .....	4-2
Initial Start Up .....	4-2
Daily Start Up .....	4-3
Process Fluid Temperature Display .....	4-4
SETPOINT .....	4-5
Status Display .....	4-6
MENU Display .....	4-7
Main Menu Tree .....	4-8
Shut Down .....	4-21

<b>Section 5</b>	<b>Additional Options/Accessories</b> .....	<b>5-1</b>
	Auto Refill .....	5-1
	Internal DI Cartridge .....	5-2
	P1 P2 T1 Pump Pressure Relief Valve (Internal Configuration) .....	5-3
	P1 P2 T1 Pump Pressure Relief Valve (External Configuration) .....	5-4
	Flow Control with Flow Readout.....	5-5
	P1 P2 T1 Pump Pressure Relief with Flow Readout.....	5-5
	T5 Pump Flow Control.....	5-6
	Anti Drainback.....	5-6
	SEMI.....	5-6
	Other Accessories.....	5-10
<b>Section 6</b>	<b>Preventive Maintenance</b> .....	<b>6-1</b>
	Preventive Maintenance Timer .....	6-1
	DIAGNOSTIC.....	6-2
	Fluid Bag Filter.....	6-3
	Fluid Diffuser .....	6-3
	Fluid Maintenance .....	6-4
	Reservoir Cleaning.....	6-4
	Condenser Filter.....	6-5
	Chiller Surface .....	6-6
	Hoses .....	6-6
	Testing the Alarm Features .....	6-7
	DI Filter (Optional) .....	6-7
	Preventive Maintenance Messages .....	6-8
<b>Section 7</b>	<b>Troubleshooting</b> .....	<b>7-1</b>
	Messages.....	7-1
	Faults and Warnings .....	7-1
	Safety Alarm .....	7-9
	Error .....	7-10
	MESSAGES.....	7-11
	Checklist.....	7-12
	TUNING .....	7-14
<b>Section 8</b>	<b>Additional Information</b> .....	<b>8-1</b>
	Draining.....	8-1
	CALIBRATION .....	8-3
	Wetted Materials.....	8-4
	Decommissioning/Disposal .....	8-5
	Shipment/Storage.....	8-5
<b>Appendix A</b>	Country Specific 230 VAC, 50 Hz, 1 Ø Requirements	
<b>Appendix B</b>	Voltage Configuration Instructions	
<b>Appendix C</b>	Serial Communications	
<b>Appendix D</b>	Analog I/O and Remote Sensor	

**Declaration of Conformity**  
**WARRANTY**



**This quick start guide is intended for initial start up only. For all other procedures you must refer to the manual. Also, if any of these steps are not clear download the manual before proceeding.**

- The chiller is designed for indoor use only. Never place the chiller in a location with excessive heat, moisture, inadequate ventilation, or corrosive materials.
- Connect the chiller to a properly grounded outlet.
- Refrigerants used are heavier than air and will replace the oxygen in a using loss of oxygen. Contact with leaking refrigerant will cause skin burns. Refer to the chiller's nameplate and the manufacturer's most current MSDS.
- Move the chiller with care. Sudden jolts or drops can damage its components. Always turn the equipment off and disconnect it from its supply voltage before moving it.
- Never operate damaged or leaking equipment.
- If your chiller is equipped with a positive displacement pump (P1 or P2), ensure your application plumbing lines and fittings are rated to withstand a minimum of 185 psi.
- Do not use a Deionization (DI) filter cartridge with Inhibited EG or Inhibited PG. A DI filter will remove inhibitors from the solution rendering the fluid ineffective against corrosion protection.
- Use only the approved fluids shown in Table 1. Before using any fluid or performing maintenance where contact with the fluid is likely, refer to the manufacturer's MSDS for handling precautions.
- To prevent freezing/glaçing of the plate exchanger, ThermoFlex 500-24000 chillers require the use of 50/50 EG/water or 50/50 PG/water below 10°C process temperature.

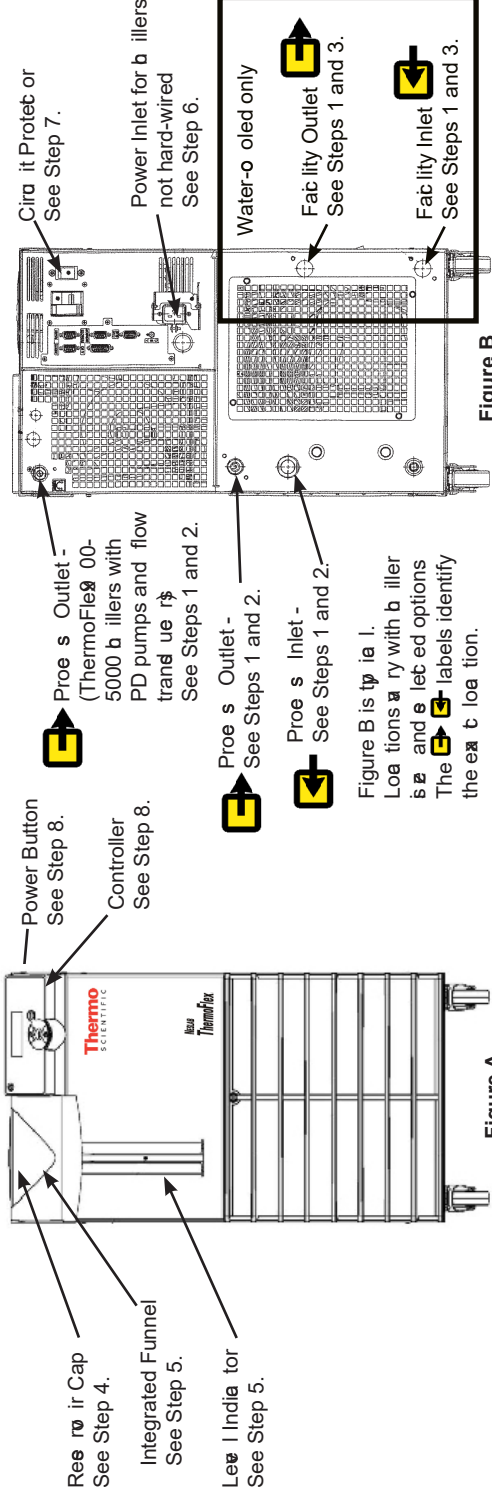

**What you need to get started:**

- An adjustable wrench
- Facility water supply and return (water-cooled chillers)
- Appropriate hose or plumbing
- Appropriate bolts, nuts or appropriate sealant
- Teflon® Tape or appropriate sealant

Facility Water Connections (FNPT)

ThermoFlex 400 - 5000 Inlet/Outlet 1/2" stainless bronze

ThermoFlex 500 - 10000 Inlet/Outlet 3/4" stainless bronze

ThermoFlex 4000 Inlet 3/4" stainless bronze

ThermoFlex 4000 Outlet 3/4" stainless steel

**Table 1 - Approved Fluids:**

Use of any other fluid will void the manufacturer's warranty.

**Standard Temp Chillers**

- Filtered/sterilized distilled water (pH 7-8)
- Deionized water (1-3 MΩ-cm, compensated)
- Distilled water with Nalco biocide and inhibitor
- Distilled water with borine (5 ppm)
- 0 - 75% Laboratory Grade Ethylene Glycol / Water
- 0 - 75% Laboratory Grade Propylene Glycol / Water

**High Temp Chillers**

- Filtered/sterilized distilled water (pH 7-8)\*
- 0 - 50% Laboratory Grade Ethylene Glycol / Water
- 0 - 50% Laboratory Grade Propylene Glycol / Water
- \*to 88°C for chillers with P1 and P2 pumps
- \*to 82°C for ThermoFlex 4000 with T9 pump
- \*to 90°C for all other chillers

Process Fluid Connections (FNPT)

- ThermoFlex 00 - 10000 P1 P2 T0 T1 1/2" stainless bronze
- ThermoFlex 500 - 5000 P3 P4 3/4" stainless bronze
- ThermoFlex 500 - 24000 P3 P5 T5 T9 1" wrought copper
- Inlet - Same size as outlet all chillers & inlets & seal
- Supplied Adapters
- P1 P2 T0 T1 1/2" x 3/8" Polyethylene and 1/2" x 1/2" Nylon
- P3 P4 3/4 MPT x 1/2 barb PVC
- P3 P5 T5 T9 1" MPT x 1" barb PVC and 1" MPT x 3/4" barb PVC

The fittings supplied for high temperature units are brass

**1** Remove all the plastic latching plugs (2 or 4).

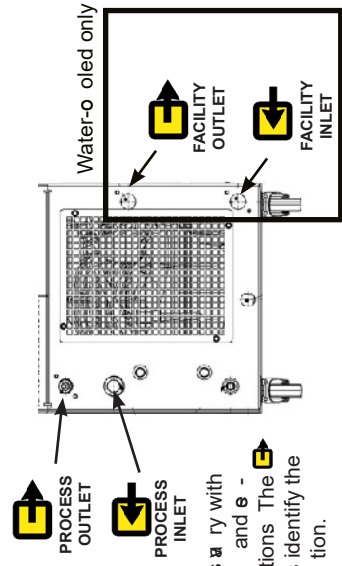

Locations vary with chiller size and selected options. The yellow and black labels identify the exact location.

See Figure B.

**5** If equipped, place the optional GFCI breaker located on the rear of the unit position. For ThermoFlex 00 through 10000 chillers, place the circuit protector to the on (I) position.

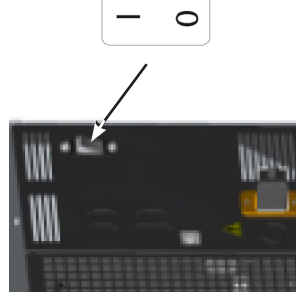

The circuit protector is not intended to act as a disconnecting means.

See Figure B.

**2** Connect the ThermoFlex PROCESS OUTLET (A) to the fluid inlet on your application. Connect the ThermoFlex PROCESS INLET (B) to the fluid outlet on your application. Ensure the connections are sealed and secure. For air-cooled chillers refer to Step 4.

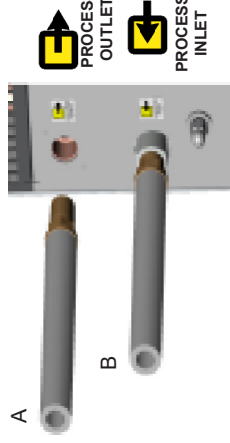

Never connect process fluid lines to your facility water supply or to any pressurized liquid source.

See Figure B.

**6** Never operate the chiller without process fluid in the reservoir or without the fluid filter bag installed.

Gently pull up on the plastic funnel housing to remove it and install the supplied filter bag. Reinstall the housing.

Remove the reservoir from the housing by unscrewing it counter-clockwise.

See Figure B.

Fluid Bag Filter



See Figure A.

**3** Connect the ThermoFlex FACILITY OUTLET (A) to a facility water return or drain. Connect the ThermoFlex FACILITY INLET (B) to a facility water supply. Ensure the connections are sealed and secure.

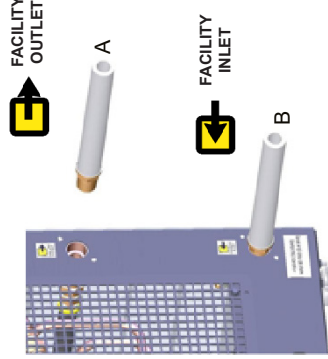

For water-cooled only. Facility Water Maximum Inlet Pressure must not exceed 150 PSIG. Facility Water Maximum Pressure Differential must not exceed 50 PSID.

See Figure B.

**7** Slowly fill reservoir with clean process fluid (see Table 1), utilizing sight tube for easy fluid level monitoring. When the reservoir is full replace the reservoir cap, hand tight. Since the reservoir capacity may be compared to your application and air may need to be purged from the lines, have extra fluid on hand to keep the system topped off when external circulation is started. If the fluid level drops too low the chiller will shut down to prevent the pump from running dry. Acknowledge the alarm and restart the priming process.

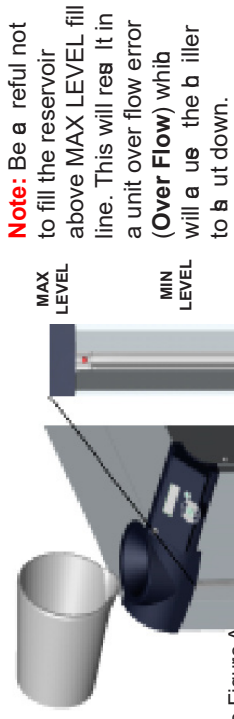

Note: Be careful not to fill the reservoir above MAX LEVEL fill line. This will result in a unit over flow error (Over Flow) which will allow the chiller to shut down.

See Figure A.

**4**

Refer to the name plate on the rear of the chiller and verify the appropriate tag. For chillers supplied with a line cord, insert female end of line cord into chiller and then insert male end of line cord into power outlet. (The line cord is located under the latching cover of the lid. Do not disconnect the lid until the cord is isolated.)



Never operate the chiller with a damaged line cord. Note: ThermoFlex 00-5000 chillers equipped with the Variable Voltage or Global Voltage option have a voltage configuration panel. Refer to the Voltage Installation Sheet supplied with the chiller, or see manual Appendix B.

Note: For chillers requiring hard wiring see Section 3 in the manual.

See Figure B.

**8** Press



The controller will display QUICK START.

Note: Before proceeding, if the chiller is equipped with a deionization filter cartridge, refer to Section 5 in the manual for installation procedure.

Please see reverse side for additional information.

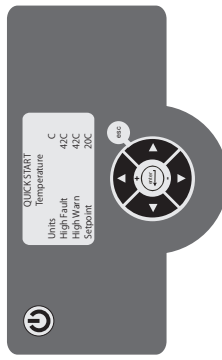

See Figure A.



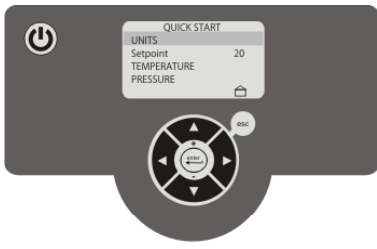

QUICK START	
UNITS	
Setpoint	20
TEMPERATURE	
PRESSURE	
FLUID LEVEL	
AUTO REFILL*	
FLOW*	
Line Frequency*	60HZ
<input type="checkbox"/> Auto Restart	
<input type="checkbox"/> Audible Alarms	
RA FAN SPEED MODE*	
Care Level	1
SERIAL COMM - DCOM*	
ANALOG COMM - ACOM*	
RESISTIVITY*	
mm/dd/yy	hh:mm:ss
◀ Quick Start Done	
*Displays only on chillers equipped with the option.	

**NOTE** Any setting can be changed after the chiller is started.

The controller can display only six lines of the QUICK START menu at a time.

**Use the down arrow to scroll through and highlight each line. If a change to any of the default settings is needed, with the desired line highlighted press the enter button.**

If the text on any setting is all capital letters, the setting has a sub-menu. Pressing enter will bring up the sub-menu. The sub-menus allow you to view/change the applicable values.

**After pressing enter the line will start to flash indicating the value can be changed using the up/down arrows. Once the desired value is displayed, press enter again to stop the flashing and accept the new value. When all the desired changes are made press the left arrow or esc key to return to the QUICK START menu.**

If the chiller exceeds the fault value it will shut down, the controller will display a fault message and, if enabled, sound the alarm. If the chiller exceeds the warning value the chiller will continue to run, the controller will display a warning message and, if enabled, sound the alarm.

Lines that are not all capital letters indicate the changes can be made directly on the QUICK START menu, i.e., Setpoint and Line Frequency. Use the same procedure to change these values.

If the line has a box, i.e., Auto Restart, pressing enter with that line highlighted will toggle between on or off. See manual for auto restart precautions and additional details.

Display	Indication	Range	Default
UNITS	Controller temperature, pressure and flow display scales. (Flow display is optional.)	C or F psi, bar or kPa	C psi
		gpm or lpm	gpm
Setpoint	Setpoint value.	+5°C to +40°C (+5°C to +90° for high temp chillers)	+20°C
TEMPERATURE	Temperature fault and warning values.	+2°C to +43°C (+93°C for high temp chillers) -8°C to +93°C for ThermoFlex24000	High +42°C (+92°C for high temp chillers) Low +3°C -7°C for ThermoFlex24000
PRESSURE	Pressure fault, warning and time delay values.  (The delay sets the length of time needed after a pressure fault before the chiller shuts down.)	Pump dependent - refer to Table 1	Pump dependent - refer to Table 1
		Time Delay: 0 to 30 seconds	High Time Delay: 0 seconds (60 seconds for P3 - P5 pumps) Low Time Delay: 10 seconds
FLUID LEVEL	Reservoir low level fault and warning values.	Heater dependent - refer to Table 3	Heater dependent - refer to Table 3
AUTO REFILL	Optional auto refill values. (On is the % of fluid level in the reservoir needed to turn refill on. Time Out is the maximum time the option will operate. Setting the time to 0 disables the option.)	On: 70%- 100%  Time Out: 0 - 900 seconds	Heater dependent, see manual
FLOW	Process fluid flow fault and warning values.	Pump dependent - refer to Table 2	Pump dependent - refer to Table 2
Line Frequency	The incoming frequency (Chillers with a P3 - P5 pump and the capability to run on either 50 Hz or 60 Hz only. The selected frequency automatically adjusts the firmware's fixed high pressure default setting.)	50 Hz or 60 Hz	60 Hz
Auto Restart	Enables the auto restart.	<input type="checkbox"/> or <input checked="" type="checkbox"/>	<input type="checkbox"/>
Audible Alarms	Enables the audible alarm.	<input type="checkbox"/> or <input checked="" type="checkbox"/>	<input type="checkbox"/>
RA FAN SPEED MODE	Fan speed. ThermoFlex2500 air-cooled chillers only (Auto allows the fan to run under the conditions listed in the manual, see Section 3. On allows the fan to run at high speed all the time.)	On or Auto	Auto
Care Level	The preventive care cleaning frequency reminder for the unit's air and fluid filters.	off, 1 (1000 hours), 2 (2000 hours) 3 (3000 hours)	Off
SERIAL COMM - DCOM	Optional serial communications. (See manual for additional information.)	Off, RS232, RS485	Off
ANALOG COMM - ACOM	Optional analog communications. (See manual for additional information.)	Refer to manual	
RESISTIVITY	Enables/configures the resistivity option. (See manual for additional information.)	<input type="checkbox"/> or <input checked="" type="checkbox"/> Setpoint: 0.2 to 3.0 MΩ-cm Interval: 0.1 to 0.5 MΩ-cm Warning High: 0.0 to 3.5 MΩ-cm Warning Low: 0.0 to 3.5 MΩ-cm	<input type="checkbox"/> Setpoint: 1.0 MΩ-cm Interval: 0.1 MΩ-cm Warning High: 3.0 MΩ-cm Warning Low: 0.5 MΩ-cm
mm/dd/yy	Sets the date. Some error messages display the date of occurrence.		
hh:mm:ss	Sets the time. Some error messages display the time of occurrence.		
Quick Start Done	To end the quick start procedure and save changes press the enter button. To leave the quick start and not save press the left arrow or esc button. In either case the screen will go blank.		

Table 1	Fault Range	High Default	Low Default
T0 T1 P1 P2 Pumps:	3 to 105 PSI	105 PSI	3 PSI
T5 Pumps:	2 to 105 PSI	105 PSI	4 PSI
P3 P4 P5 Pumps:	See Manual	See Manual	4 PSI
T9 Pumps:	3 to 105 PSI	105 PSI	3 PSI

Table 2	Range	High Default	Low Default
T0 T1 P1 P2 Pumps:	0.0 to 10.5 GPM	0.0 GPM	0.0 GPM
T5 Pumps:	0.0 to 15.0 GPM	0.0 GPM	0.0 GPM
P3 P4 P5 Pumps:	0.0 to 30.0 GPM	0.0 GPM	0.0 GPM
T9 Pumps:	0.0 to 33.5 GPM	0.0 GPM	0.0 GPM

Table 3	Warning Range	Default
Heater		
None	6 - 100%	6%
1 kW:	58 - 100%	58%
2.3 kW:	69 - 100%	69%
5.0 kW:	87 - 100%	87%
4.6 kW:	87 - 100%	87%

Table 3	Fault Range	Default
Heater		
None	0 - 100%	0%
1 kW:	52 - 100%	52%
2.3 kW:	63 - 100%	63%
5.0 kW:	81 - 100%	81%
4.6 kW:	81 - 100%	81%





**Ce guide de démarrage rapide est destiné à la mise en marche initiale uniquement. Pour toute autre procédure, merci de vous référer au manuel. De plus, si l'une de ses étapes ne vous paraît pas claire, téléchargez le manuel avant de commencer.**

**Sécurité :**

- Les refroidisseurs ont été conçus pour fonctionner uniquement à l'intérieur. Ne jamais exposer le refroidisseur à une chaleur ou une humidité excessive, à une ventilation inadéquate ou à des matières corrosives.
- Brancher le refroidisseur à une prise correctement reliée à la terre.
- Les réfrigérants utilisés sont plus lourds que l'air et peuvent remplacer l'oxygène, provoquant ainsi une perte de conscience. Tout contact avec des réfrigérants qui fuient peut provoquer des brûlures cutanées. Pour plus d'informations, se reporter à la plaque signalétique du refroidisseur et à la Fiche de données de sécurité (MSDS) du fabricant la plus récemment utilisée.
- Débrancher le refroidisseur au cas échéant. Les sécheresses peuvent endommager les composants et provoquer un incendie. À chaque déplacement de l'équipement, toujours le mettre hors tension et le débrancher de son alimentation.
- Ne jamais utiliser un équipement endommagé ou qui présente des fuites.

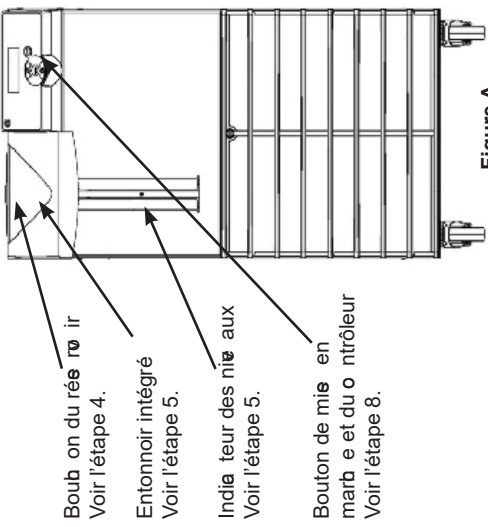

Figure A

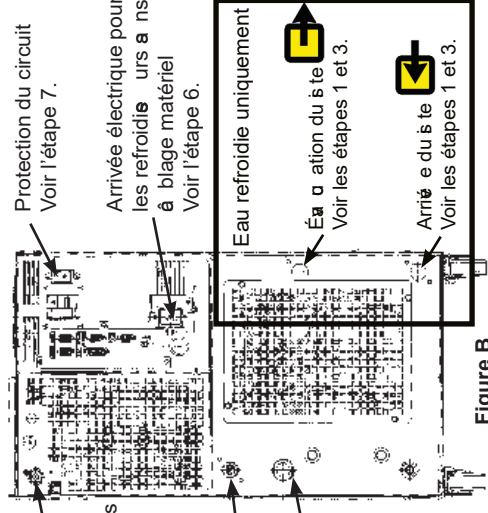

Figure B

**Matériel nécessaire pour commencer :**

- Une clé à molette
- Alimentation et évacuation d'eau du site (pour les refroidisseurs refroidis par eau)
- Tuyaux et accessoires de plomberie appropriés
- Colliers de serrage ou raccords de montage appropriés
- Ruban adhésif au Teflon® ou produit étanchéifiant approprié

**Raccordements à l'eau du site (FNPT)**

- ThermoFlex1400 - 5000 Arrivée/Sortie fonte de bronze 0,5"
- ThermoFlex7500 - 10000 Arrivée/Sortie fonte de bronze 0,75"
- ThermoFlex24000 Arrivée 3/4" fonte de bronze
- ThermoFlex24000 Sortie 3/4" acier inoxydable

**Les raccords fournis pour les unités haute température sont en laiton**

- P1 P2 T0 T1 Polyéthylène 0,5" x 0,375" et Nylon 0,5" x 0,5"
- P3 P4 MPT 0,75 x PVC cannelé 0,5"
- P3 P5 T5 T9 MPT 1" x PVC cannelé 1" et MPT 1" x PVC cannelé 0,75"

- Raccordements du fluide de traitement (FNPT)
- Sortie
- TFlex900 - 10000 P1 P2 T0 T1
- TFlex3500 - 5000 P3 P4
- TFlex7500 - 24000 P3 P5 T5 T9
- Arrivée - Taille identique à la sortie de tous les refroidisseurs en acier inoxydable
- Adaptateurs fournis

- Si le refroidisseur est équipé d'une pompe à déplacement positif (P1 ou P2), s'assurer que les conduites de plomberie et les raccords de l'application peuvent supporter au moins 185 psi.
- Ne pas utiliser de cartouche de filtre de déionisation (DI) avec EG ou PG inhibés. Un filtre DI retiendra les inhibiteurs de la solution, rendant le liquide inefficace sur la protection contre la corrosion. Les inhibiteurs augmenteront également la conductivité du liquide.
- Utiliser uniquement les liquides approuvés et énumérés dans le Tableau 1. Avant d'utiliser un quelconque liquide ou d'effectuer des travaux d'entretien susceptibles d'entraîner un contact avec le liquide, se reporter à la Fiche de données de sécurité du fabricant.
- Pour éviter toute congélation/glaçage de l'échangeur à plaques, les refroidisseurs ThermoFlex7500-24000 requièrent l'utilisation d'EG/eau 50/50 ou de PG/eau 50/50 à une température inférieure de 10°C à celle du traitement.

Tableau 1 - Liquides approuvés :	
Tout autre liquide annule la garantie du fabricant.	
<b>Refrroidisseurs température standard</b>	
Eau filtrée/mono-distillée (pH 7-8)	
Eau déionisée (1 à 3 MΩ-cm, compensée)	
Eau diluée avec biot de Nalco et ses inhibiteurs	
Eau diluée avec biore (5 ppm)	
Éthylène glycol de qualité laboratoire/eau 0 à 75 %	
Propylène glycol de qualité laboratoire/eau 0 à 75 %	
<b>Refrroidisseurs haute température</b>	
Eau filtrée (pH 7-8)*	
Éthylène glycol de qualité laboratoire/eau 0 à 50%	
Propylène glycol de qualité laboratoire/eau 0 à 50%	
*jusqu'à 88°C pour les refroidisseurs équipés des pompes P1 et P2	
*jusqu'à 82°C pour ThermoFlex24000 avec pompe T9	
*jusqu'à 90°C pour les refroidisseurs équipés d'autres fonte de bronze 0,5"	
fonte de bronze 0,75"	
cuivre forgé 1"	

**1** Retirer tous les bouchons d'expédition en plastique (2 ou 4).

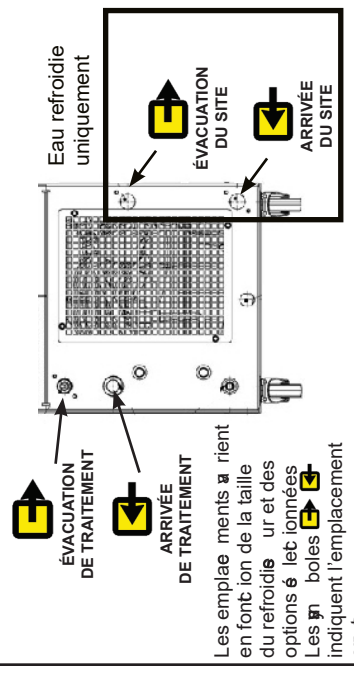

Les emplacements à retirer en fonction de la taille du refroidisseur et des options sélectionnées. Les boîtes indiquent l'emplacement exact.

Voir la Figure B.

**5** Si le refroidisseur en est équipé, armer le disjoncteur GFCI en position haute. Pour les refroidisseurs ThermoFlex900 jusqu'à 10000, mettre le dispositif de protection du circuit à l'arrière de l'appareil en position haute.

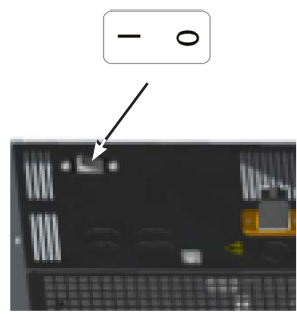

**Le dispositif de protection du circuit n'a pas été conçu pour déconnecter les appareils.**

Voir la Figure B.

**2** Raccorder l'évacuation de traitement ThermoFlex (A) à l'arrivée de liquide de l'application. Raccorder l'arrivée de traitement ThermoFlex (B) à l'évacuation de liquide de l'application. Vérifier que les raccords sont étanches et sûrs. Pour les refroidisseurs refroidis par air, passer à l'étape 4.

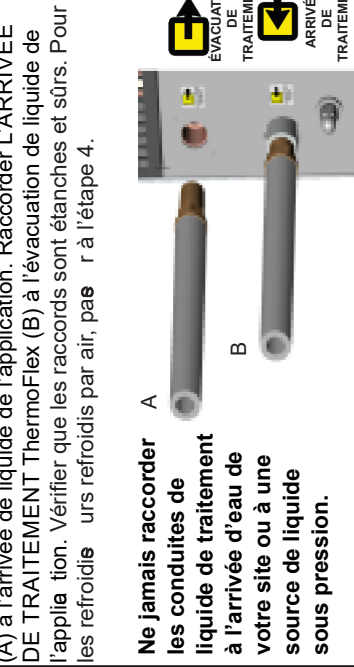

Voir la Figure B.

**6** Ne jamais utiliser le refroidisseur sans liquide dans le réservoir et/ou sans avoir installé le filtre sac.



Merci de tirer avec précaution sur la partie plastique du cache type entonnoir pour l'enlever et ensuite installer le filtre sac fourni. Une fois cette opération achevée, merci de repositionner le cache type entonnoir.

Voir la Figure A.

**3** Raccorder l'évacuation du site ThermoFlex (A) à une arrivée d'eau du site. Raccorder l'arrivée du site ThermoFlex (B) à une arrivée d'eau du site. Vérifier que les raccords sont étanches et sûrs.

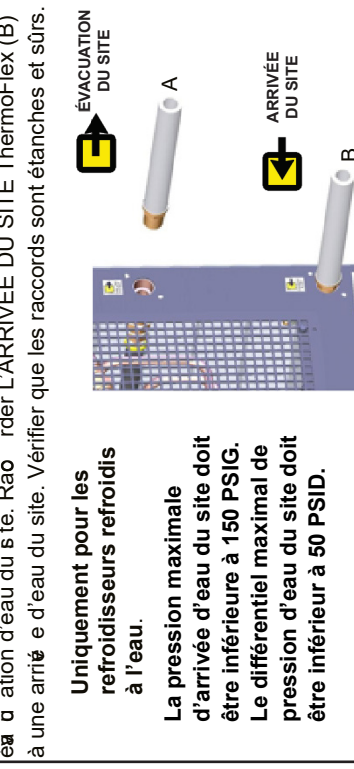

Voir la Figure B.

**7** Remplir lentement le réservoir avec du liquide de traitement propre (voir le Tableau 1) en utilisant le regard pour contrôler facilement le niveau de liquide. Une fois le réservoir rempli, remettre le bouchon en le serrant à la main. La pression de l'eau doit être réduite par rapport à l'application, et l'air devant être purgé des conduites, garder du liquide supplémentaire à portée de la main pour faire l'appoint du système une fois la circulation démarrée.

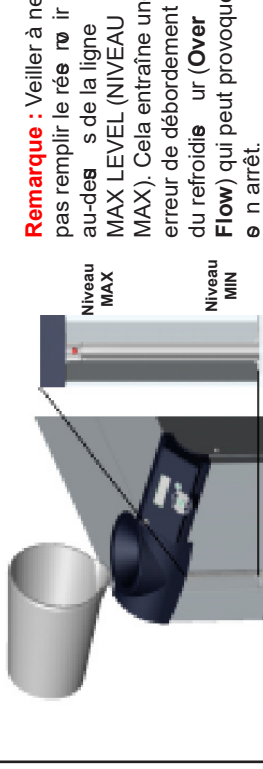

Voir la Figure A.

**4** Se reporter à la plaque signalétique située à l'arrière du refroidisseur et vérifier que la tension est correcte. Pour les refroidisseurs fournis avec un cordon d'alimentation, insérer l'extrémité femelle de ce dernier dans le refroidisseur, et l'extrémité mâle dans la prise électrique. (Le cordon d'alimentation se trouve sous le couvercle de la caisse d'expédition. Ne pas jeter le couvercle avant d'avoir localisé le cordon.)

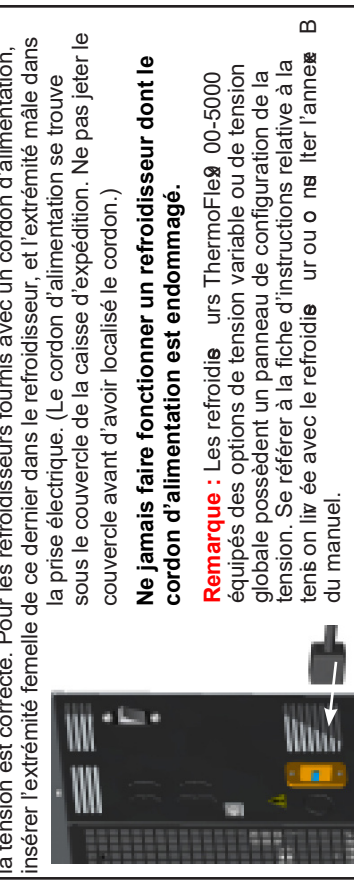

Voir la Figure B.

**8** Appuyer sur le bouton QUICK START.

Le contrôleur affiche QUICK START.

**Remarque :** Si le refroidisseur est équipé d'une cartouche de filtre de déionisation, remplacer le filtre, pour l'installation.

**Voir au dos les étapes supplémentaires.**

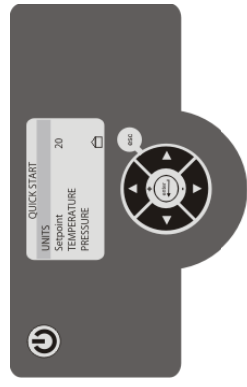

Voir la Figure A.

**Remarque :** Pour les refroidisseurs exigeant un câblage matériel, consulter la section 3 du manuel.

**Remarque :** Les refroidisseurs ThermoFlex 00-5000 équipés des options de tension variable ou de tension globale possèdent un panneau de configuration de la tension. Se référer à la fiche d'instructions relative à la tension on livrée avec le refroidisseur ou consulter l'anneau B du manuel.



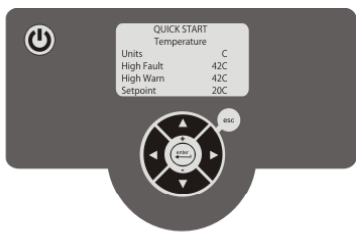

MISE EN ROUTE RAPIDE	
<b>UNITS (UNITÉS)</b>	
<b>Point de consigne</b>	<b>20</b>
<b>TEMPÉRATURE</b>	
<b>PRESSURE (PRESSION)</b>	
<b>FLUID LEVEL (NIVEAU DE LIQUIDE)</b>	
<b>REPLISSAGE AUTOMATIQUE*</b>	
<b>DÉBIT*</b>	
<b>Fréquence de ligne*</b>	<b>60 Hz</b>
<input type="checkbox"/> <b>Auto Restart (Redémarrage automatique)</b>	
<input type="checkbox"/> <b>Alarmes sonores</b>	
<b>MODE DE VITESSE DE VENTILATION PR*</b>	
<b>Care Level (Niveau d'entretien)</b>	<b>1</b>
<b>COM SÉRIE - DCOM*</b>	
<b>COM ANALOGUE - ACOM*</b>	
<b>RÉSISTIVITÉ*</b>	
<b>mm/jj/aa</b>	<b>hh:mm:ss</b>
<b>◀ Quick Start Done (Mise en route rapide effectuée)</b>	
*Uniquement sur les refroidisseurs équipés de l'option.	

**REMARQUE** Tous les réglages peuvent être modifiés une fois que le refroidisseur a démarré.

Le contrôleur ne peut afficher que six lignes du menu QUICK START à la fois.

**Utiliser la flèche bas pour faire défiler et mettre en surbrillance chaque ligne. S'il est nécessaire de modifier l'un des réglages par défaut, mettre la ligne souhaitée en surbrillance puis appuyer sur le bouton Enter (Entrée).**

Si le texte d'un réglage est complètement en majuscules, le réglage comporte un sous-menu. Appuyer sur le bouton Enter (Entrée) pour afficher le sous-menu. Les sous-menus vous permettent de visualiser/modifier les valeurs applicables.

Dès que l'on a appuyé sur le bouton Enter (Entrée), la ligne se met à clignoter pour indiquer que la valeur peut être modifiée à l'aide des flèches haut/bas. Une fois que la valeur souhaitée est affichée, appuyer de nouveau sur Enter (Entrée) pour faire cesser le clignotement et accepter la nouvelle valeur. Lorsque toutes les modifications souhaitées sont effectuées, appuyer sur la flèche gauche ou sur la touche Esc (Échap) pour revenir au menu QUICK START.

Si le refroidisseur dépasse la valeur de défaillance, il s'éteindra, le contrôleur affichera un message d'erreur et, si elle activée, l'alarme sonore se déclenchera. Si le refroidisseur dépasse la valeur d'avertissement, il continuera de fonctionner, le contrôleur affichera un message d'avertissement et, si elle activée, l'alarme sonore se déclenchera.

Les lignes qui ne comportent pas que des majuscules indiquent que les modifications peuvent être effectuées directement dans le menu QUICK START (exemple : Setpoint et Line Frequency). Suivre la même procédure pour modifier ces valeurs.

Si une ligne comporte une case vide (exemple : Auto Restart), le fait d'appuyer sur le bouton Enter (Entrée) avec la ligne concernée mise en surbrillance rendra la case noire. Une case noire indique que la fonction est activée. Appuyer de nouveau sur Enter (Entrée) pour que la case soit vide. Une case vide indique que la fonction est désactivée.

Affichage	Instructions	Plage	Valeur par défaut
UNITS	Échelles d'affichage du débit, de la pression et de la température du contrôleur. (L'affichage du débit est en option.)	C ou F psi, bar ou kPa gpm ou lpm	C psi gpm
Setpoint	Valeur du point de consigne.	De +5°C à +40°C (De +5°C à +90°C pour les refroidisseurs haute température)	+20°C
TEMPERATURE	Valeurs de défaillance de la température et d'avertissement.	De +2°C à +43°C (+93°C pour les refroidisseurs haute température) De -8 °C à + 93°C pour ThermoFlex24000	Élevée +42°C (+92°C pour les refroidisseurs haute température) Faible +3°C -7 °C pour ThermoFlex24000
PRESSURE	Valeurs de défaillance de la pression, d'avertissement et de laps de temps. (Le délai est défini par le temps nécessaire avant l'arrêt du refroidisseur suite à une défaillance de pression.)	En fonction de la pompe ; se référer au Tableau 1 Laps de temps : de 0 à 30 secondes	En fonction de la pompe ; se référer au Tableau 1 Laps de temps élevé : 0 secondes (60 secondes pour les pompes P3 à P5) Laps de temps faible : 10 secondes
FLUID LEVEL	Valeurs d'avertissement et de niveau faible dans le réservoir.	En fonction du chauffage ; se référer au Tableau 3	En fonction du chauffage ; se référer au Tableau 3
AUTO REFILL	Valeurs de remplissage automatique en option. (On correspond au pourcentage de niveau de liquide dans le réservoir nécessaire pour lancer le remplissage. Le délai d'expiration est la durée maximale pendant laquelle l'option va fonctionner. Paramétrer la durée sur 0 désactive l'option.)	On : de 70 % à 100 % Time Out : de 0 à 900 secondes	En fonction du chauffage, consulter le manuel
FLOW	Valeurs d'avertissement et de défaillance du processus de débit de liquide.	En fonction de la pompe ; se référer au Tableau 2	En fonction de la pompe ; se référer au Tableau 2
Line Frequency	Fréquence d'entrée (Refroidisseurs équipés d'une pompe P3 à P5 et ayant la capacité de fonctionner à 50 Hz ou à 60 Hz uniquement. La fréquence sélectionnée ajuste automatiquement le réglage de haute pression par défaut fixe du microprogramme.)	50 Hz ou 60 Hz	60 Hz
Auto Restart	Active le redémarrage automatique.	<input type="checkbox"/> ou <input checked="" type="checkbox"/>	<input type="checkbox"/>
Audible Alarms	Active l'alarme sonore.	<input type="checkbox"/> ou <input checked="" type="checkbox"/>	<input type="checkbox"/>
RA FAN SPEED MODE	Vitesse de ventilation. Refroidisseurs refroidis par air ThermoFlex2500 uniquement (Auto permet au ventilateur de fonctionner dans les conditions énumérées dans le manuel, voir la section 3. On permet au ventilateur de fonctionner tout le temps à vitesse élevée.)	On ou Auto	Auto
Care Level	Rappel de nettoyage d'entretien préventif pour les filtres à air et à liquide du refroidisseur.	Off, 1 (1 000 heures), 2 (2 000 heures) 3 (3 000 heures)	Off
SERIAL COMM - DCOM	Communications série en option. (Consulter le manuel pour toute information complémentaire.)	Off, RS232, RS485	Off
ANALOG COMM - ACOM	Communications analogues en option. (Consulter le manuel pour toute information complémentaire.)	Se reporter au manuel	
RESISTIVITY	Active/Configure l'option de résistivité. (Consulter le manuel pour toute information complémentaire.)	<input type="checkbox"/> ou <input checked="" type="checkbox"/> Point de consigne : de 0,2 à 3,0 MΩ-cm Intervalle : de 0,1 à 0,5 MΩ-cm Avertissement élevé : de 0,0 à 3,5 MΩ-cm Avertissement faible : de 0,0 à 3,5 MΩ-cm	<input type="checkbox"/> Point de consigne : 1,0 MΩ-cm Intervalle : 0,1 MΩ-cm Avertissement élevé : 3,0 MΩ-cm Avertissement faible : 0,5 MΩ-cm
mm/dd/yy (mm/jj/aa)	Paramètre la date. Certains messages d'erreur affichent la date d'apparition.		
hh:mm:ss	Paramètre l'heure. Certains messages d'erreur affichent l'heure d'apparition.		
Quick Start Done	Pour terminer la procédure de mise en route rapide et enregistrer les modifications, appuyer sur le bouton Enter (Entrée). Pour quitter la mise en route rapide et ne pas enregistrer, appuyer sur la flèche gauche ou sur le bouton Esc (Échap). Dans les deux cas, l'écran deviendra vide.		

Tableau 1	Plage de défaillance	Valeur par défaut élevée	Valeur par défaut faible
<b>Pompes</b>			
T0 T1 P1 P2 :	de 3 à 105 PSI	105 PSI	3 PSI
Pompes T5 :	de 2 à 105 PSI	105 PSI	4 PSI
<b>Pompes</b>			
P3 P4 P5 :	Consulter le manuel	Consulter le manuel	4 PSI
Pompes T9 :	de 3 à 105 PSI	105 PSI	3 PSI

Tableau 2	Plage	Valeur par défaut élevée	Valeur par défaut faible
<b>Pompes</b>			
T0 T1 P1 P2 :	de 0,0 à 10,5 GPM	0,0 GPM	0,0 GPM
Pompes T5 :	de 0,0 à 15,0 GPM	0,0 GPM	0,0 GPM
<b>Pompes</b>			
P3 P4 P5 :	de 0,0 à 30,0 GPM	0,0 GPM	0,0 GPM
Pompes T9 :	de 0,0 à 33,5 GPM	0,0 GPM	0,0 GPM

Tableau 3	Plage d'avertissement	Valeur par défaut
<b>Chauffage</b>		
Aucun	6 - 100 %	6 %
1 kW :	58 - 100 %	58 %
2,3 kW :	58 ou 69 - 100 %	58 ou 69 %
5,0 kW :	87 - 100 %	87 %
4,6 kW :	87 - 100 %	87 %
<b>Chauffage</b>		
Aucun	0 - 100 %	0 %
1 kW :	52 - 100 %	52 %
2,3 kW :	52 ou 63 - 100 %	52 ou 63 %
5,0 kW :	81 - 100 %	81 %
4,6 kW :	81 - 100 %	81 %





**Diese Kurzanleitung ist nur für die erste Inbetriebnahme vorgesehen. Für alle anderen Verfahren müssen Sie im Handbuch nachsehen. Auch wenn irgendwelche Schritte unverständlich sind, laden Sie das Handbuch herunter, bevor Sie fortfahren.**

**Sicherheit:**

- Das Kühlgerät darf nur in geschlossenen Räumen betrieben werden. Stellen Sie das Kühlgerät niemals an Orten auf, wo es übermäßiger Hitze, Feuchtigkeit, unzureichender Belüftung oder korrosiven Stoffen ausgesetzt ist.
- Schließen Sie das Kühlgerät an eine ordnungsgemäß geerdete Steckdose an.
- Da die verwendeten Kühlmittel schwerer als Luft sind und den Sauerstoff verdrängen, kann es zu Bewusstlosigkeit kommen. Der Kontakt mit auslaufendem Kühlmittel kann Hautverbrennungen verursachen. Weitere Informationen finden Sie auf dem Typenschild des Kühlgerätes sowie im aktuellen Sicherheitsdatenblatt (SDB) des Herstellers.
- Bewegen Sie das Kühlgerät vorsichtig. Plötzliche Erschütterungen oder Stürze können seine Bauteile beschädigen. Schalten Sie das Gerät immer ab und trennen Sie es von der Versorgungsspannung, bevor Sie das Gerät bewegen.
- Betreiben Sie niemals beschädigte oder undichte Geräte.

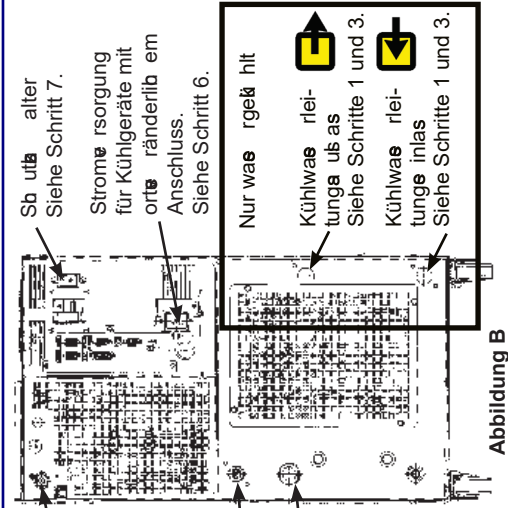
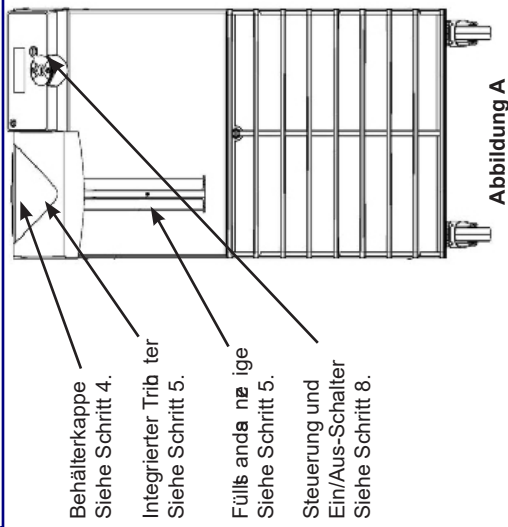

Prozessauslass – (ThermoFlex900-5000 Kühlgeräte mit Verdängerpumpen und Durchflusssensoren) Siehe Schritte 1 und 2.

Prozesseinlass – Siehe Schritte 1 und 2.

Abbildung B ist eine Beispiellabbildung. Die Anschlussstellen variieren je nach Größe des Kühlgeräts und gewählten Optionen. Die Etiketten kennzeichnen die genaue Position.

Siehe Schritt 7.

Stromversorgung für Kühlgeräte mit externer Stromversorgung

Nur wasergekühlt

Kühlwasserleitung – Siehe Schritte 1 und 3.

Kühlwasserleitung – Siehe Schritte 1 und 3.

**Sie benötigen für die Inbetriebnahme:**

- Einen röhrenelastischen Schlauch für Prozessflüssigkeiten (FNPT)
- Leitungsadapter für den Prozessflüssigkeiten
- Passende Schlauchstücke
- Teflon®-Band oder geeignete Dichtung

Kühlwasserleitung – Siehe Schritt 1

ThermoFlex1400 – 5000 Einlass/Auslass 1/2"

ThermoFlex7500 – 10000 Einlass/Auslass 3/4"

ThermoFlex24000 Einlass 3/4" Gussbronze

ThermoFlex24000 Auslass 3/4" Edelstahl

Anschlüsse für Prozessflüssigkeiten (FNPT)	Außenschlanschlüsse
TFlex900 – 10000	P1 P2 T0 T1 1/2" Gussbronze
TFlex3500 – 5000	P3 P4 3/4" Gussbronze
TFlex7500 – 24000	P3 P5 T5 T9 1" geschmiedetes Kupfer

Einlass – Gleiche Größe wie Auslass alle Kühlgeräte Edelstahl

Mittelgroße Adapter

P1 P2 T0 T1 1/2" x 3/8" Polyethylen und 1/2" x 1/2" Nylon

P3 P4 3/4 Außengewinde x 1/2 PVC-Verbindungsstück

P3 P5 T5 T9 1" Außengewinde x 1" PVC-Verbindungsstück und 1" Außengewinde x 3/4" PVC-Verbindungsstück

Die für Hochtemperaturgeräte gelieferten Armaturen sind aus Messing

- Falls Ihr Kühlgerät mit einer Verdängerpumpe (P1 oder P2) ausgestattet ist, stellen Sie sicher, dass die Leitungen und Anschlüsse einem Druck von mindestens 185 psi/12,8 bar standhalten.
- Verwenden Sie keine Deionisierung (DI)-Filterkartusche bei inhibiertem EG oder inhibiertem PG. Mit einem DI-Filter werden Inhibitoren aus der Lösung entfernt und dadurch wird die Korrosionsschutzwirkung der Flüssigkeit aufgehoben. Inhibitoren erhöhen auch die Leitfähigkeit der Flüssigkeit.
- Verwenden Sie nur die in Tabelle 1 gezeigten zugelassenen Flüssigkeiten. Beachten Sie die im Datenblatt des Herstellers angegebenen Vorbehalte. Verwenden Sie keine Flüssigkeiten in Berührung kommen, oder eine Wartung durchführen, bei der Sie möglicherweise mit Flüssigkeiten in Berührung kommen.
- Um ein Einfrieren bzw. Vereisen des Plattenwärmetauschers zu vermeiden, müssen bei Betriebstemperaturen unter 10 °C für ThermoFlex7500-24000 Kühlgeräte 50/50 EG/Wasser oder 50/50 PG/Wasser verwendet werden.

**Tabelle 1 – Zugelassene Flüssigkeiten:**

Die Verwendung anderer Flüssigkeiten führt zum Verlust der Herstellergarantie.

**Standardtemperaturkühlgeräte**

Filtertes/einfach destilliertes Wasser (pH 7–8)

Deionisiertes Wasser (1–3 MΩ-cm, kompensiert)

Destilliertes Wasser mit Natriumbisphosphat und Inhibitor

Destilliertes Wasser mit Chlor (5 ppm)

0 – 75 % Ethylenglykol/Wasser in Laborqualität

0 – 75 % Propylenglykol/Wasser in Laborqualität

**Hochtemperaturkühlgeräte**

Filtertes Wasser (pH 7–8)\*

0 – 50% Ethylenglykol/Wasser in Laborqualität

0 – 50% Propylenglykol/Wasser in Laborqualität

\*bis 88 °C für Kühlgeräte mit P1- und P2-Pumpen

\*bis 82 °C für ThermoFlex24000 mit T9 Pumpe

\*bis 90 °C für Kühlgeräte mit anderen Pumpen

**1** Entfernen Sie alle Kunststoff-Versandstopfen (2 oder 4).

Nur wasergekühlt

PROZESS AUSLASS

PROZESS EINLASS

Die Außenschlanschlüsse variieren je nach Größe des Kühlgeräts und gewählten Optionen. Die Etiketten kennzeichnen die genaue Position.

Siehe Abbildung B.

**5** Falls vorhanden, stellen Sie den optionalen FI-Schutzschalter in die obere Position. Bei ThermoFlex900 bis 10000 Kühlgeräten stellen Sie den Schalter in die Position Ein (I).

**Der Schutzschalter ist nicht zum Ausschalten des Gerätes vorgesehen.**

Siehe Abbildung B.

**2** Verbinden Sie den ThermoFlex PROZESSAUSGANG (A) mit dem Flüssigkeitseingang Ihrer Applikation. Verbinden Sie den ThermoFlex PROZESSEINGANG (B) mit dem Flüssigkeitseingang Ihrer Applikation. Überprüfen Sie, dass die Verbindungen dicht und gesichert sind. Luftgekühlte Kühlgeräte: Weiter mit Schritt 4.

**Schließen Sie niemals Prozessflüssigkeiten an die Kühlwasserleitung an, wenn die Kühlwasserleitung unter Druck steht.**

Siehe Abbildung B.

**6** **Betreiben Sie niemals den Kühler ohne Prozessflüssigkeit im Behälter oder ohne installiertem Flüssigkeitfilterbeutel.**

Flüssigkeitfilterbeutel

Ziehen Sie vorsichtig an dem Kunststoffträger des Gehäuses um es zu entfernen und installieren Sie die mitgelieferte Filterbeutel. Danach bauen Sie das Gehäuse wieder zusammen.

Siehe Abbildung A.

**3** Verbinden Sie den ThermoFlex KÜHLWASSERLEITUNGS-AUSLASS (A) mit Ihrem Wasserrücklauf oder -abfluss. Verbinden Sie den ThermoFlex KÜHLWASSERLEITUNGS-EINLASS (B) mit einer Wasserleitung. Überprüfen Sie, dass die Verbindungen dicht und gesichert sind.

**Nur wasergekühlt.**

**Der maximale Einlassdruck des Kühlwassers darf 10,35 bar nicht überschreiten. Die maximale Druckdifferenz des Kühlwassers darf 3,4 bar nicht überschreiten.**

Siehe Abbildung B.

**7** Befüllen Sie den Behälter langsam mit sauberer Prozessflüssigkeit (siehe Tabelle 1) und kontrollieren Sie den Füllstand über die Füllstandsanzeige. Wenn der Behälter voll ist, schrauben Sie die Behälterkappe handfest auf. Da möglicherweise die Kapazität des Behälters im Vergleich zu Ihrer Applikation eher gering ist und Luft aus den Leitungen gespült werden muss, sollten Sie weitere Flüssigkeit zum Nachfüllen bereithalten, wenn der externe Kreislauf gestartet wird.

**Hinweis:** Abhängig von der Behältergröße über die Markierung MAX LEVEL zu befüllen. Dies führt zu einem Überlauf-Fehler (Overflow) und mit einer Abfüllung des Kühlgerätes.

Siehe Abbildung A.

**4** Kontrollieren Sie, ob die korrekte Spannung eingestellt ist, die Sie auf dem Typenschild auf der Rückseite des Kühlgerätes finden. Stecken Sie bei Kühlgeräten mit Stromkabel zunächst das geräte-seitige Ende in das Kühlgerät und anschließend den Stecker in eine Steckdose. (Das Stromkabel befindet sich unter dem Deckel der Transportkiste. Werfen Sie den Deckel nicht weg, bevor Sie das Stromkabel gefunden haben.)

**Betreiben Sie das Kühlgerät niemals mit einem beschädigten Stromkabel.**

**Hinweis:** ThermoFlex900-5000 Kühlgeräte mit der Option Variabler Spannungsbereich verfügen über ein Bedienfeld zur Konfiguration der Spannung. Siehe mitgelieferte Anweisung zum Einstellen der Spannung oder Anhang B im Handbuch.

**Hinweis:** Für Kühlgeräte, bei denen ein Fehler erforderlich ist, siehe Abschnitt 3 im Handbuch.

Siehe Abbildung B.

**8** Drücken Sie auf .

Daraufhin zeigt die Steuerung **Quick Start (SCHNELLSTART)** an.

**Hinweis:** Falls das Kühlgerät mit einer Deionisierung Filterbeutel ausgestattet ist, finden Sie Hinweise zum Einsetzen in Abschnitt 5 des Handbuchs.

**Weitere Schritte siehe Rückseite.**

Siehe Abbildung A.



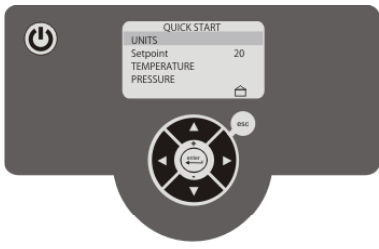

QUICK START (SCHNELLSTART)	
UNITS (EINHEITEN)	
Setpoint (Sollwert)	20
TEMPERATURE (TEMPERATUR)	
PRESSURE (DRUCK)	
FLUID LEVEL (FÜLLSTAND)	
AUTO REFILL (AUTOM. NACHFÜLLUNG)*	
FLOW (FLUSS)*	
Line Frequency (Netz frequenz *)	60HZ
<input type="checkbox"/> Auto Restart (Autom. Neustart)	
<input type="checkbox"/> Audible Alarms (Akustische Alarme)	
RA FAN SPEED MODE (RA-LÜFTERDREHZAHLMODUS)*	
Care Level (Wartungserinnerung)	Off
SERIAL COMM – DCOM (SERIELLE KOMMUNIKATION – DCOM)	
ANALOG COMM – ACOM (ANALOGUE KOMMUNIKATION – ACOM)*	
RESISTIVITY (WIDERSTAND)*	
mm/dd/yy (mm/tt/jj)	hh:mm:ss
<b>Quick Start Done (Schnellstart beenden)</b>	
* Wird nur auf Kühlern angezeigt, die mit dieser Option ausgestattet sind.	

**HINWEIS** Alle Einstellungen können nach dem Starten des Kühlers geändert werden.

Auf dem Regler werden maximal 6 bis 7 Zeilen des Menüs QUICK START (SCHNELLSTART) gleichzeitig angezeigt.

**Mit dem Pfeil nach unten können Sie die Zeilen durchblättern und markieren. Wenn eine Standardeinstellung geändert soll, markieren Sie die gewünschte Zeile, und drücken Sie ENTER.**

Bei einer Einstellung in Großbuchstaben geben Sie ein Untermenü an. Mit ENTER öffnen Sie das Untermenü. In den Untermenüs können Sie die entsprechenden Werte abrufen bzw. ändern.

Sobald Sie ENTER drücken, beginnt die Zeile zu blinken. Dies bedeutet, dass der Wert nun mit dem Pfeil nach oben und unten geändert werden kann. Blättern Sie zum gewünschten Wert, und drücken Sie erneut ENTER. Die Einstellung blinkt nicht mehr, und der neue Wert ist festgelegt. Wenn Sie alle gewünschten Änderungen vorgenommen haben, drücken Sie den Pfeil nach links oder ESC. Damit gelangen Sie zum Menü QUICK START (SCHNELLSTART) zurück.

Überbleibt der Kühler den Fehlerwert, wird das Gerät ausgelastet. Auf dem Regler wird eine Fehlermeldung angezeigt, und ein akustischer Alarm ertönt (siehe hierzu die Bedienungsanleitung). Überbleibt der Kühler den Warnwert, bleibt das Gerät weiterhin ausgelastet. Auf dem Regler wird eine Warnmeldung angezeigt, und ein akustischer Alarm ertönt (siehe hierzu die Bedienungsanleitung).

Bei Zeilen, die nicht vollständig in Großbuchstaben angezeigt werden, können Sie die Änderungen direkt im Menü QUICK START (SCHNELLSTART) vornehmen. Dies gilt für die Optionen „Setpoint“ (Sollwert) und „Line Frequenz“ (Netz frequenz). Diese Werte lassen sich auf dieselbe Weise wie die anderen Einstellungen ändern.

Bei einer Zeile ein leeres Kästchen bedeutet, z. B. bei „Auto Restart“ (Autom. Neustart), wird das Kästchen bei Bedarf bald die betreffende Zeile markieren und ENTER drücken. Ein leeres Kästchen bedeutet, dass die zugehörige Funktion aktiviert ist. Wenn Sie erneut ENTER drücken, wird wieder ein leeres Kästchen angezeigt. Ein leeres Kästchen bedeutet, dass die zugehörige Funktion deaktiviert ist.

Anzeige	Inhalt	Bereich	Standardwert
UNITS (EINHEITEN)	Einheiten für die Temperatur-, Druck- und Flussanzeige auf dem Regler. (Die Flussanzeige ist optional.)	C oder F psi, bar oder kPa gpm oder lpm	C psi gpm
Setpoint (Sollwert)	Sollwert.	+5 °C bis +40 °C (+90 °C bei Hochtemperaturkühlern)	+20 °C
TEMPERATURE (TEMPERATUR)	Fehler- und Warnwerte für die Temperatur.	+2 °C bis +43 °C (+93 °C bei Hochtemperaturkühlern) –8 °C bis +93 °C für ThermoFlex24000	High (Obergrenze): +42 °C (+92 °C bei Hochtemperaturkühlern) Low (Untergrenze): +3 °C –7 °C für ThermoFlex24000
PRESSURE (DRUCK)	Fehler-, Warn- und Zeitverzögerungswerte für den Druck.  (Die Verzögerung bestimmt den Zeitraum, nach dessen Ablauf der Kühler ausgeschaltet wird, wenn ein fehlerhafter Druck vorliegt.)	Je nach Pumpe; siehe Tabelle 1  Time Delay (Zeitverzögerung): 0–30 Sekunden	Je nach Pumpe; siehe Tabelle 1  High Time Delay (Obergrenze für Zeitverzögerung): 0 Sekunden (60 Sekunden bei P3- bis P5-Pumpen) Low Time Delay (Untergrenze für Zeitverzögerung): 10 Sekunden
FLUID LEVEL (FÜLLSTAND)	Fehler- und Warnwerte für niedrigen Füllstand im Behälter.	Je nach Heizung; siehe Tabelle 3	Je nach Heizung; siehe Tabelle 3
AUTO REFILL (AUTOM. NACHFÜLLUNG)	Optionale Werte für die automatische Nachfüllung. „On“ [Ein] bezeichnet den Prozentsatz des Füllstands im Behälter, bei dem die Nachfüllung eingeschaltet wird. „Time Out“ [Zeitüberschreitung] bezeichnet den maximalen Zeitraum, über den diese Option aktiv sein soll. Wird dieser Zeitraum auf 0 gesetzt, so wird die Option deaktiviert.)	On (Ein): 70–100 %  Time Out (Zeitüberschreitung): 0–900 Sekunden	Je nach Heizung; siehe Handbuch
FLOW (FLUSS)	Fehler- und Warnwerte für den Fluss der Prozessflüssigkeit.	Je nach Pumpe, siehe Tabelle 2	Je nach Pumpe, siehe Tabelle 2
Line Frequency (Netzfrequenz)	Eingangsfrequenz (Kühler mit P3- bis P5-Pumpe und Möglichkeit zum Betrieb mit 50 Hz oder 60 Hz. Über die gewählte Frequenz wird die festgelegte Überdruck-StandardEinstellung der Firmware automatisch justiert.)	50 Hz oder 60 Hz	60 Hz
Auto Restart (Autom. Neustart)	Ermöglicht den automatischen Neustart.	<input type="checkbox"/> oder <input checked="" type="checkbox"/>	<input type="checkbox"/>
Audible Alarms (Akustische Alarme)	Aktiviert akustische Alarme.	<input type="checkbox"/> oder <input checked="" type="checkbox"/>	<input type="checkbox"/>
RA FAN SPEED MODE (RA-LÜFTERDREHZAHLMODUS)	Lüfterdrehzahl. Nur für luftgekühlte Kühler Modell ThermoFlex2500. (Ermöglicht den automatischen Betrieb des Lüfters gemäß den im Handbuch aufgeführten Bedingungen; siehe Abschnitt 3. Bei „On“ [Ein] läuft der Lüfter durchgängig mit der höchsten Drehzahl.)	„On“ (Ein) oder „Auto“	Auto
Care Level (Wartungserinnerung)	Erinnerung an die Reinigung der Luft- und Flüssigkeitsfilter des Geräts im Rahmen der vorbeugenden Wartung.	Off (Aus), 1 (1000 Stunden), 2 (2000 Stunden), 3 (3000 Stunden)	Off
SERIAL COMM – DCOM (SERIELLE KOMMUNIKATION – DCOM)	Optionale serielle Kommunikation. (Weitere Informationen siehe Handbuch.)	Off (Aus), RS232, RS485	Off (Aus)
ANALOG COMM – ACOM (ANALOGUE KOMMUNIKATION – ACOM)	Optionale analoge Kommunikation. (Weitere Informationen siehe Handbuch.)	Siehe Handbuch.	
RESISTIVITY (WIDERSTAND)	Aktiviert/konfiguriert die Option für den Widerstand. (Weitere Informationen siehe Handbuch.)	<input type="checkbox"/> oder <input checked="" type="checkbox"/> Setpoint (Sollwert): 0,2–3,0 MΩ-cm Interval (Intervall): 0,1–0,5 MΩ-cm Warning High (Obere Warngrenze): 0,0–3,5 MΩ-cm Warning Low (Untere Warngrenze): 0,0–3,5 MΩ-cm	<input type="checkbox"/> Setpoint (Sollwert): 1,0 MΩ-cm Interval (Intervall): 0,1 MΩ-cm Warning High (Obere Warngrenze): 3,0 MΩ-cm Warning Low (Untere Warngrenze): 0,5 MΩ-cm
mm/dd/yy (mm/tt/jj)	Stellt das Datum ein. In einigen Fehlermeldungen wird das Datum des Fehlers angezeigt.		
hh:mm:ss	Stellt die Uhrzeit ein. In einigen Fehlermeldungen wird die Uhrzeit des Fehlers angezeigt.		
Quick Start Done (Schnellstart beenden)	Zum Beenden des Schnellstartverfahrens und zum Speichern der Änderungen drücken Sie ENTER. Um den Schnellstart abzubrechen ohne zu speichern, drücken Sie den Pfeil nach links oder ESC. In beiden Fällen schaltet sich die Bildschirmanzeige aus.		

Tabelle 1	Fehlerbereich	Standard-Obergrenze	Standard-Untergrenze	Tabelle 3	Warnbereich	Standardwert
T0-, T1-, P1-, P2-Pumpe:	3–105 psi	105 psi	3 psi	Heizung	6–100 %	6 %
T5 Pumpe:	2–105 psi	105 psi	4 psi	Keine	58–100 %	58 %
P3-, P4-, P5-Pumpe:	Siehe Handbuch	Siehe Handbuch	4 psi	1 kW:	69–100 %	69 %
T9 Pumpe:	3 to 105 psi	105 psi	3 psi	2,3 kW:	87–100 %	87 %
				5,0 kW:	87–100 %	87 %
				4,6 kW:	87–100 %	87 %

Tabelle 2	Bereich	Standard-Obergrenze	Standard-Untergrenze	Tabelle 3	Fehlerbereich	Standardwert
T0-, T1-, P1-, P2-Pumpe:	0,0–10,5 gpm	0,0 gpm	0,0 gpm	Heizung	0–100 %	0 %
T5 Pumpe:	0,0–15,0 gpm	0,0 gpm	0,0 gpm	Keine	52–100 %	52 %
P3-, P4-, P5-Pumpe:	0,0–30,0 gpm	0,0 gpm	0,0 gpm	1 kW:	63–100 %	63 %
T9 Pumpe:	0,0 to 33,5 gpm	0,0 gpm	0,0 gpm	2,3 kW:	81–100 %	81 %
				5,0 kW:	81–100 %	81 %
				4,6 kW:	81–100 %	81 %





**Scopo di questa guida rapida è facilitare la messa in funzione iniziale. Per tutte le altre procedure è necessario fare riferimento al manuale. Se alcuni dei passaggi qui riportati non risultano chiari, scaricare il manuale prima di proseguire.**

**Tabella 1 - Liquidi approvati:**

L'uso di qualsiasi altro liquido annullerà la garanzia del produttore.
<b>Refrigeratori a temperature standard</b> Acqua distillata/filtrata (pH 7-8) Acqua deionizzata (1-3 MΩ-cm, compensata) Acqua distillata o non biocida o inibitore Nalo Acqua distillata o non biocida o inibitore Nalo 0 - 75% etilenglicolo/ acqua per laboratorio 0 - 75% propilenglicolo/ acqua per laboratorio
<b>Refrigeratori a temperature elevate</b> Acqua filtrata (pH 7-8)* 0 - 50% etilenglicolo/ acqua per laboratorio 0 - 50% propilenglicolo/ acqua per laboratorio * a 88°C per refrigeratori con pompe P1 e P2 * a 82°C per ThermoFlex24000 con pompe T9 * a 90°C per refrigeratori con altre pompe

- Se il refrigeratore è dotato di pompa volumetrica (P1 o P2), verificare che le tubazioni idrauliche e i raccordi previsti per l'applicazione siano progettati per essere una pressione minima di 185 psf.
- Non utilizzare una cartuccia filtro per deionizzazione (DI) con etilenglicolo o propilenglicolo inibito. Il filtro rimuove gli inibitori dalla soluzione rendendo il liquido inefficace contro la protezione dalla corrosione. Inoltre, gli inibitori aumentano la conduttività del liquido.
- Utilizzare solo i liquidi approvati riportati nella tabella 1. Prima di utilizzare i liquidi o essere utilizzati in ambienti di manutenzione e potrebbero implicare il contatto con il liquido, fare riferimento alle schede di sicurezza dei materiali (MSDS) del produttore per le precauzioni d'uso.
- Per impedire il congelamento dello sbrinatori, i refrigeratori ThermoFlex 500-24000 richiedono l'uso di 50/50 di etilenglicolo/ acqua o propilenglicolo/ acqua per temperature di processo inferiori a 10°C.



Figura A



Figura B

- Elementi necessari per la messa in funzione:**
- Una bottiglia regolabile
  - Alimentazione e ritorno acqua dell'impianto (refrigeratori ad acqua)
  - Tubazioni rigide o flessibili idonee
  - Tipo di raccordi o dimensioni appropriate adeguati
  - Nastro adesivo Teflon® o sigillante idoneo
- Raccordi acqua dell'impianto (FNPT)  
ThermoFlex1400 - 5000 Ingressi/uscite in bronzo fuso da 1/2"  
ThermoFlex7500 - 10000 Ingressi/uscite in bronzo fuso da 3/4"  
ThermoFlex4000 Ingressi in bronzo fuso da 3/4"  
ThermoFlex4000 Uscite in acciaio inox da 3/4"
- Raccordi forniti:  
P1 P2 T0 T1 in polietilene da 1/2" x 3/8" e in nylon da 1/2" x 1/2"  
P3 P4 MPT 3/4 x raso dento in PVC 1/2"  
P3 P5 T5 T9 MPT 1" x raso dento in PVC 1" e MPT 1" x raso dento in PVC 3/4"  
I raccordi forniti per le unità ad alta temperatura sono in ottone

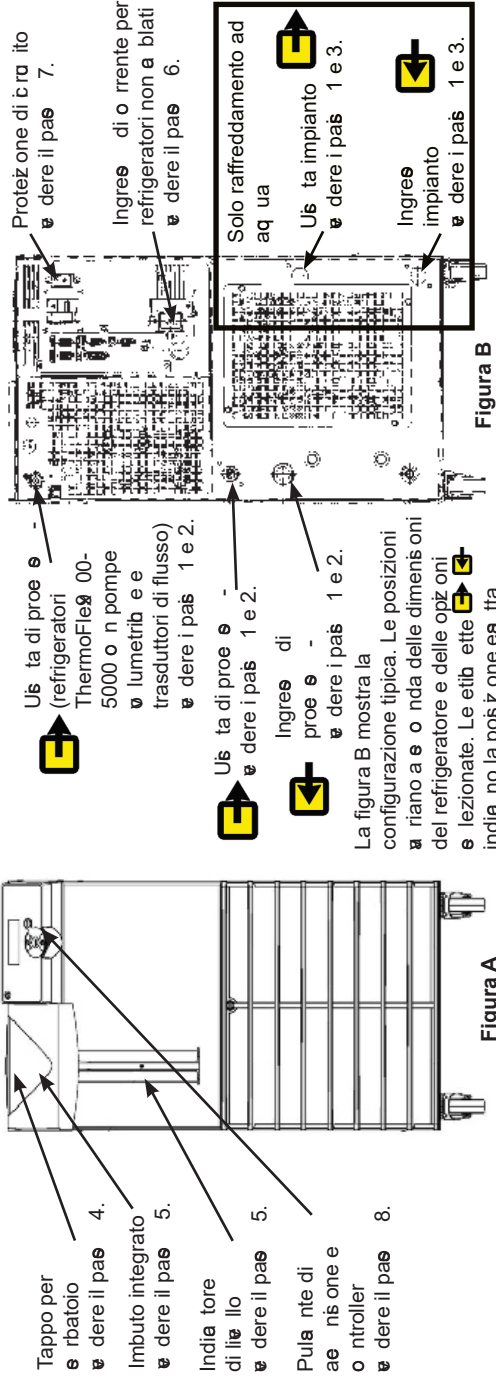
**1** Rimuovere tutti i tappi di protezione (2 o 4).  
Solo raffreddamento ad acqua.  
Uscita processo, Ingresso processo, Uscita impianto, Ingresso impianto.

Le posizioni e le dimensioni delle opzioni selezionate. Le etichette indicano la posizione esatta.  
Vedere la figura B.

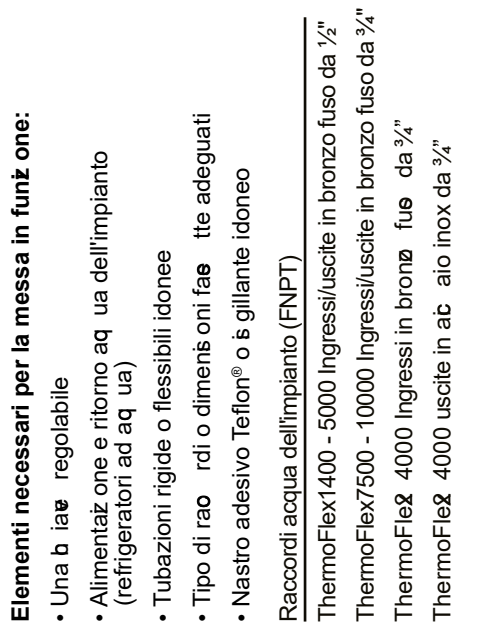
**5** Se in dotazione, portare l'interruttore GFCI opzionale situato sul retro nella posizione sollevata. Per i refrigeratori compresi tra ThermoFlex900 e 10000, portare la protezione di circuito nella posizione attiva (I).

**La protezione di circuito non è progettata per agire come strumento di scollegamento.**

**2** Collegare l'USCITA DI PROCESSO ThermoFlex (A) all'ingresso liquido per l'applicazione. Collegare l'INGRESSO DI PROCESSO ThermoFlex (B) all'uscita liquida per l'applicazione. Verificare che i raccordi siano ben saldati e sigillati. Per i refrigeratori ad aria andare al paragrafo 4.

**Non collegare le tubazioni dei liquidi di processo all'alimentazione d'acqua dell'impianto o a qualsiasi altra sorgente di liquido pressurizzato.**  
Vedere la figura B.

**6** Non azionare il refrigeratore senza liquido di processo nel serbatoio.  
Rimuovere il tappo del serbatoio e stendere l'antiorario.

**7** Riempire lentamente il serbatoio con liquido di processo pulito (vedere la tabella 1), utilizzando il tubo per controllare il livello del liquido. Quando il serbatoio è pieno, riappiattare il tappo e girare a mano. Poiché la pressione potrebbe essere inferiore al necessario per l'applicazione, l'aria potrebbe essere aspirata dalle tubazioni, tenere a portata di mano del liquido e aspirare il serbatoio o del ricambio.

**Nota:** fare attenzione a non riempire il serbatoio al di sopra della tacca di livello MAX. Ciò determinerà la generazione di un errore di troppo pieno che causerà l'arresto del refrigeratore.

**3** Collegare l'USCITA IMPIANTO ThermoFlex (A) a una tubazione di ritorno o al ritorno dell'acqua dell'impianto. Collegare l'INGRESSO IMPIANTO ThermoFlex (B) all'alimentazione acqua dell'impianto. Verificare che i raccordi siano ben saldati e sigillati.

**Solo per il raffreddamento ad acqua.**  
**La pressione di ingresso massima dell'acqua dell'impianto non deve superare i 150 PSIG. Il differenziale di pressione massimo dell'acqua dell'impianto non deve superare i 50 PSID.**  
Vedere la figura B.

**4** Fare riferimento alla targhetta identificativa sul retro del refrigeratore e verificare la tensione corretta. Per i refrigeratori forniti con un cavo di alimentazione, inserire l'estremità femmina del cavo nel refrigeratore e l'estremità maschio nella presa di corrente. (Il cavo di alimentazione si trova sotto il coperchio della cassa per la spedizione. Non gettare il coperchio fino a quando non si trova il cavo.)  
**Non azionare il refrigeratore con un cavo di alimentazione danneggiato.**  
**Nota:** i refrigeratori ThermoFlex900-5000 dotati dell'opzione di tensione variabile o globale hanno un pannello di configurazione della tensione. Fare riferimento al foglio delle istruzioni relative alla tensione spedito con il refrigeratore o vedere l'Appendice B al manuale.  
**Nota:** per i refrigeratori che richiedono il cablaggio vedere la sezione 3 del manuale.

**8** Premere il pulsante QUICK START.  
Sul pannello di controllo premere il pulsante QUICK START.

**Nota:** se il refrigeratore viene dotato di una cartuccia filtro per deionizzazione fare riferimento alla sezione 5 del manuale per informazioni sull'installazione.

**Consultare il retro per ulteriori procedure.**

**5** Se in dotazione, portare l'interruttore GFCI opzionale situato sul retro nella posizione sollevata. Per i refrigeratori compresi tra ThermoFlex900 e 10000, portare la protezione di circuito nella posizione attiva (I).

**La protezione di circuito non è progettata per agire come strumento di scollegamento.**

**6** Non azionare il refrigeratore senza liquido di processo nel serbatoio.  
Rimuovere il tappo del serbatoio e stendere l'antiorario.

**7** Riempire lentamente il serbatoio con liquido di processo pulito (vedere la tabella 1), utilizzando il tubo per controllare il livello del liquido. Quando il serbatoio è pieno, riappiattare il tappo e girare a mano. Poiché la pressione potrebbe essere inferiore al necessario per l'applicazione, l'aria potrebbe essere aspirata dalle tubazioni, tenere a portata di mano del liquido e aspirare il serbatoio o del ricambio.

**Nota:** fare attenzione a non riempire il serbatoio al di sopra della tacca di livello MAX. Ciò determinerà la generazione di un errore di troppo pieno che causerà l'arresto del refrigeratore.

**8** Premere il pulsante QUICK START.  
Sul pannello di controllo premere il pulsante QUICK START.

**Nota:** se il refrigeratore viene dotato di una cartuccia filtro per deionizzazione fare riferimento alla sezione 5 del manuale per informazioni sull'installazione.

**Consultare il retro per ulteriori procedure.**

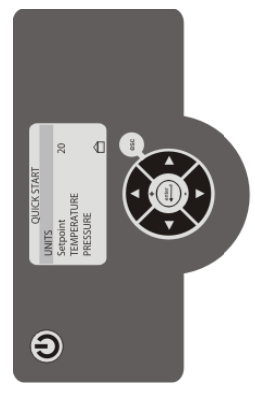

Vedere la figura A.

Vedere la figura A.

Vedere la figura B.

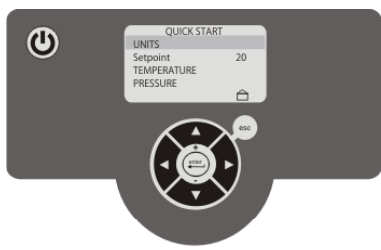

## QUICK START

<b>UNITS</b>	
<b>Setpoint</b>	<b>20</b>
<b>TEMPERATURE</b>	
<b>PRESSURE</b>	
<b>FLUID LEVEL</b>	
<b>AUTO REFILL*</b>	
<b>FLOW*</b>	
<b>Line Frequency*</b>	<b>60HZ</b>
<input type="checkbox"/> <b>Auto Restart</b>	
<input type="checkbox"/> <b>Audible Alarms</b>	
<b>RA FAN SPEED MODE*</b>	
<b>Care Level</b>	<b>Off</b>
<b>SERIAL COMM - DCOM*</b>	
<b>ANALOG COMM - ACOM*</b>	
<b>RESISTIVITY*</b>	
<b>mm/dd/yy</b>	<b>hh:mm:ss</b>
<b>Quick Start Done</b>	

\*Vengono visualizzati solo i refrigeratori dotati di tale opzione.

**NOTA** Le impostazioni possono essere modificate solo dopo l'avvio del refrigeratore.

Sul controller possono essere visualizzate solo sei righe del menu QUICK START alla volta.

**Utilizzare la freccia giù per scorrere ed evidenziare ciascuna riga. Per modificare un'impostazione predefinita, evidenziare la riga interessata e premere il pulsante Enter.**

Se il testo di un'impostazione è tutto in maiuscolo, è presente un sottomenu. Premendo il pulsante Enter viene visualizzato il sottomenu. I sottomenu consentono di visualizzare/modificare i valori applicabili.

Dopo aver premuto il pulsante Enter, la riga inizia a lampeggiare a indicare che il valore può essere modificato tramite le frecce su/giù. Una volta visualizzato il valore desiderato, premere nuovamente il pulsante Enter per non far lampeggiare più la riga e accettare il nuovo valore. Una volta apportate tutte le modifiche desiderate, premere la freccia sinistra o il tasto Esc per tornare al menu QUICK START.

Se il valore di guasto viene superato, il refrigeratore viene spento, sul controller viene visualizzato il messaggio di errore e, se abilitato, viene emesso l'allarme acustico. Se il valore di avviso viene superato, il refrigeratore continua a funzionare, sul controller viene visualizzato il messaggio di avviso e, se abilitato, viene emesso l'allarme acustico.

Le righe che non sono tutte in maiuscolo indicano che le modifiche possono essere apportate direttamente nel menu QUICK START (ad esempio, Setpoint e Line Frequency). Utilizzare la stessa procedura per modificare questi valori.

Se la riga contiene un quadratino bianco (ad es., Auto Restart), premendo il pulsante Enter con quella riga evidenziata, il quadratino diventa nero. Un quadratino nero indica che la funzione è abilitata. Premere nuovamente Enter per visualizzare nuovamente il quadratino bianco. Un quadratino bianco indica che la funzione è disabilitata.

Display	Significato	Intervallo	Impostazione predefinita
UNITS	Scale di visualizzazione di temperatura, pressione e flusso del controller. (La visualizzazione del flusso è opzionale.)	C o F psi, bar o kPa gpm o lpm	C psi gpm
Setpoint	Valore di impostazione.	Da +5°C a +40°C (Da +5°C a +90° per refrigeratori a temperature elevate)	+20°C
TEMPERATURE	Valori guasto o avviso temperatura.	Da +2°C a +43°C (+93°C per refrigeratori a temperature elevate) Da -8 °C a + 93 °C per ThermoFlex24000	Valore alto +42°C (+92°C per refrigeratori temp. elevate) Valore basso +3°C -7 °C per ThermoFlex24000
PRESSURE	Valori guasto, avviso e ritardo pressione.  (Il ritardo imposta il tempo ammesso dopo un guasto di pressione prima che il refrigeratore venga spento.)	Variabile in base alla pompa - fare riferimento alla tabella 1  Time Delay: Da 0 a 30 secondi	Variabile in base alla pompa - fare riferimento alla tabella 1  High Time Delay: 0 secondi (60 secondi per pompe P3 - P5) Low Time Delay: 10 secondi
FLUID LEVEL	Valori guasto e avviso basso livello di liquido nel serbatoio.	Variabile in base al riscaldatore - fare riferimento alla tabella 3	Variabile in base al riscaldatore - fare riferimento alla tabella 3
AUTO REFILL	Valori di rabbocco automatico opzionale. (On è la % di livello del liquido nel serbatoio necessaria per attivare il rabbocco. Time Out è il tempo massimo di esecuzione dell'opzione. Impostando il tempo su 0 l'opzione viene disabilitata.)	On: 70% - 100%  Time Out: 0 - 900 secondi	Variabile in base al riscaldatore, vedere il manuale
FLOW	Valori guasto e avviso flusso liquido di processo.	Variabile in base alla pompa - fare riferimento alla tabella 2	Variabile in base alla pompa - fare riferimento alla tabella 2
Line Frequency	La frequenza in entrata (refrigeratori con una pompa P3 - P5 e capacità di funzionamento solo a 50 Hz o 60 Hz. La frequenza selezionata regola automaticamente l'impostazione predefinita dell'alta pressione fissa del firmware.)	50 Hz o 60 Hz	60 Hz
Auto Restart	Consente il riavvio automatico.	<input type="checkbox"/> o <input checked="" type="checkbox"/>	<input type="checkbox"/>
Audible Alarms	Attiva l'allarme acustico.	<input type="checkbox"/> o <input checked="" type="checkbox"/>	<input type="checkbox"/>
RA FAN SPEED MODE	Velocità ventola. Solo refrigeratori ThermoFlex2500 raffreddati ad aria (Auto consente il funzionamento della ventola nelle condizioni indicate nel manuale, vedere la sezione 3. On consente il funzionamento della ventola sempre ad alta velocità.)	On o Auto	Auto
Care Level	Il promemoria di frequenza manutenzione preventiva di pulizia per i filtri aria e liquido del refrigeratore.	Off, 1 (1000 ore), 2 (2000 ore) 3 (3000 ore)	Off
SERIAL COMM - DCOM	Comunicazioni seriali opzionali. (Per ulteriori informazioni, vedere il manuale.)	Off, RS232, RS485	Off
ANALOG COMM - ACOM	Comunicazioni analogiche opzionali. (Per ulteriori informazioni, vedere il manuale.)	Fare riferimento al manuale	
RESISTIVITY	Attiva/configura l'opzione di resistività. (Per ulteriori informazioni, vedere il manuale.)	<input type="checkbox"/> o <input checked="" type="checkbox"/> Setpoint: Da 0,2 a 3,0 MΩ-cm Interval: Da 0,1 a 0,5 MΩ-cm Warning High: Da 0,0 a 3,5 MΩ-cm Warning Low: Da 0,0 a 3,5 MΩ-cm	<input type="checkbox"/> Setpoint: 1,0 MΩ-cm Interval: 0,1 MΩ-cm Warning High: 3,0 MΩ-cm Warning Low: 0,5 MΩ-cm
mm/dd/yy	Consente di impostare la data nel formato mm/gg/aa. Alcuni messaggi di errore mostrano la data in cui si è verificato l'evento.		
hh:mm:ss	Consente di impostare l'ora. Alcuni messaggi di errore mostrano l'ora in cui si è verificato l'evento.		
Quick Start Done	Per terminare la procedura di avvio rapido e salvare le modifiche premere il pulsante Enter. Per chiudere la procedura di avvio rapido senza salvare, premere la freccia sinistra o il pulsante Esc. In entrambi i casi, lo schermo si spegnerà.		

Tabella 1	Intervallo guasto	Imp. predefinita max	Imp. predefinita min
Pompe T0 T1 P1 P2:	Da 3 a 105 PSI	105 PSI	3 PSI
Pompe T5:	Da 2 a 105 PSI	105 PSI	4 PSI
Pompe P3 P4 P5:	Vedere il manuale	Vedere il manuale	4 PSI
T9 Pompe:	3 to 105 PSI	105 PSI	3 PSI

Tabella 2	Intervallo	Imp. predefinita	Imp. predefinita max/min
Pompe T0 T1 P1 P2:	Da 0,0 a 10,5 GPM	0,0 GPM	0,0 GPM
Pompe T5:	Da 0,0 a 15,0 GPM	0,0 GPM	0,0 GPM
Pompe P3 P4 P5:	Da 0,0 a 30,0 GPM	0,0 GPM	0,0 GPM
T9 Pompe:	Da 0,0 a 33,5 GPM	0,0 GPM	0,0 GPM

Tabella 3	Riscaldatore	Intervallo di avviso	Imp. predefinita
Nessuno	6 - 100%	6%	
1 kW:	58 - 100%	58%	
2,3 kW:	58 o 96 - 100%	58 o 69%	
5,0 kW:	87 - 100%	87%	
4,6 kW:	87 - 100%	87%	

Tabella 3	Riscaldatore	Intervallo guasto	Imp. predefinita
Nessuno	0 - 100%	0%	
1 kW:	52 - 100%	52%	
2,3 kW:	52 o 63 - 100%	52 o 63%	
5,0 kW:	81 - 100%	81%	
4,6 kW:	81 - 100%	81%	





**Esta guía de puesta en marcha rápida se ha elaborado únicamente para el arranque inicial. Para obtener información sobre otros procedimientos, debe consultar el manual. Asimismo, en caso de que tuviera dudas sobre alguno de estos pasos, descargue el manual antes de continuar.**

**Seguridad:**

- El enfriador es diseñado para usarse en interiores. No lo coloque en lugares o en áreas con alta humedad o con presencia de materiales corrosivos.
- Conecte el enfriador a una toma de tierra adecuada.
- Los refrigerantes utilizados son más pesados que el aire, por lo que sustituirán al oxígeno y provocarán la pérdida del conocimiento. Evite que entre en contacto con el refrigerante procedente de fugas o produzcan quemaduras en la piel. Consulte la placa identificativa del enfriador y la hoja de datos de seguridad de materiales (MSDS) más actual del fabricante.
- Mueva el enfriador con cuidado. Los saltos repentinos o las caídas pueden dañar sus componentes. Apague siempre el equipo y desconéctelo de la tensión eléctrica antes de moverlo.
- Nunca ponga en funcionamiento un equipo que esté dañado o que presente fugas.

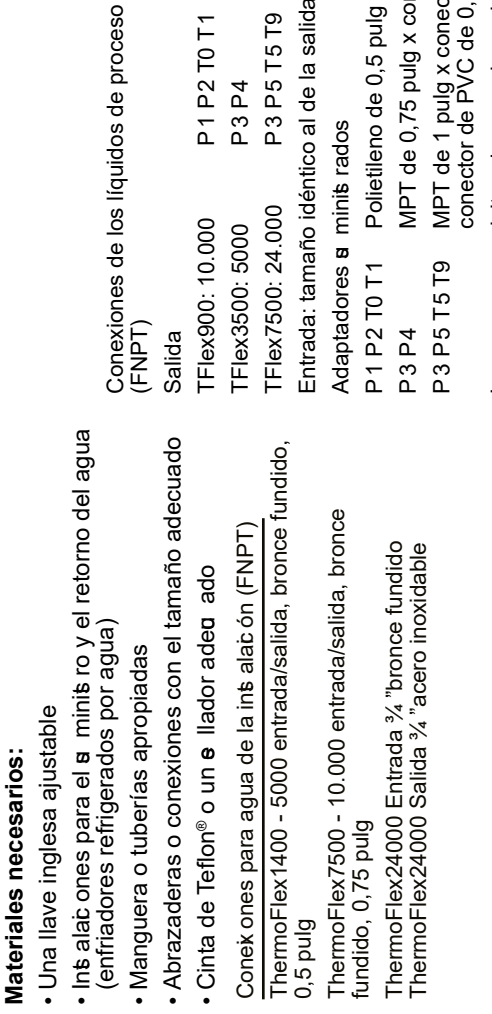
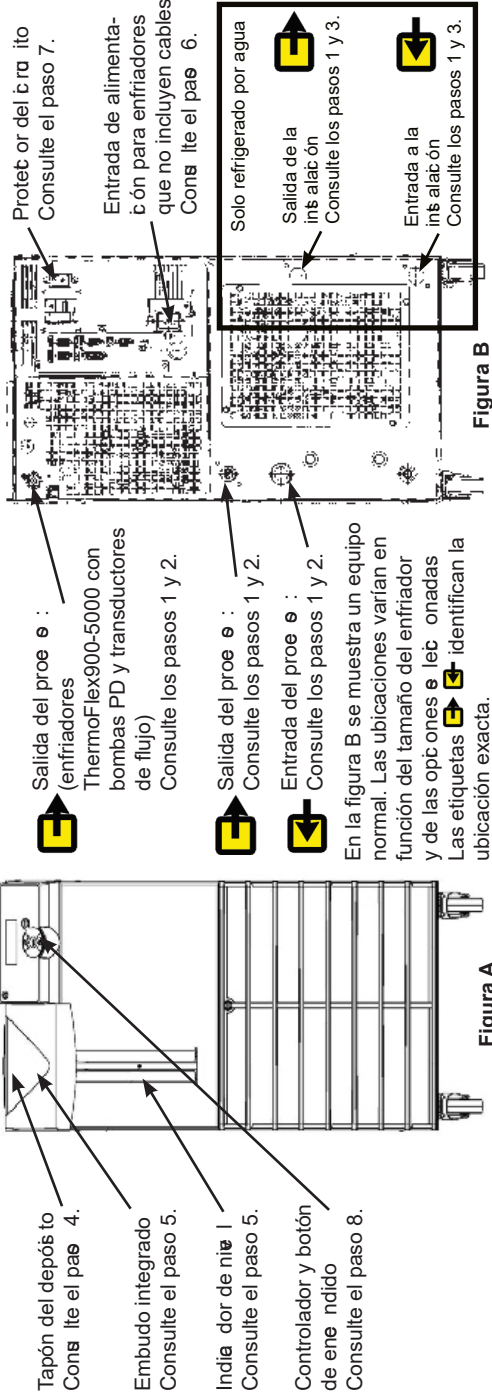

**1** Retire los plásticos de embalaje de los enchufes (2 o 4).

**2** Conecte la SALIDA DE PROCESO de ThermoFlex (A) a la entrada de líquidos de su aplicación. Conecte la ENTRADA DE PROCESO de ThermoFlex (B) a la salida de líquidos de su aplicación. Asegúrese de que las conexiones se han cerrado y fijado correctamente. Para los enfriadores refrigerados por aire, o nitrato de amonio, consulte el paso 4.

**3** Conecte la SALIDA DE LA INSTALACIÓN de ThermoFlex (A) a un depósito o retorno de agua a la instalación. Conecte la ENTRADA A LA INSTALACIÓN de ThermoFlex (B) a un depósito de agua. Asegúrese de que las conexiones se han cerrado y fijado correctamente.

**4** Consulte la placa identificativa de la parte posterior del enfriador y compruebe la tensión apropiada. Para los enfriadores que se suministran con un cable de alimentación, inserte el extremo hembra del cable de alimentación en el enfriador y, a continuación, inserte el extremo macho del cable de alimentación en la toma eléctrica (el cable de alimentación se ubica debajo de la tapa de la caja de transporte. No deseches la tapa hasta que haya encontrado el cable).

**5** Si se selecciona el modo de funcionamiento de alta temperatura, consulte la sección 3 del manual.

**6** Nunca ponga en marcha el chiller sin líquido refrigerante en el tanque o sin la bolsa de filtro instalada.

**7** Lentamente rellene el depósito con líquido de proceso limpio (consulte la tabla 1). Utilice el tubo de control de nivel para controlar con facilidad el nivel de líquido. Cuando el depósito esté lleno, vuelva a colocar el tapón del depósito y apriételo a mano. Ya que la presión del depósito puede ser pequeña para la aplicación de que se trate y posiblemente deba purgar el aire de los tubos, tenga a mano líquido extra para mantener el sistema lleno al máximo nivel de líquido de proceso.

**8** Pulse el botón de inicio.

**9** En el controlador de modo de funcionamiento de alta temperatura, consulte la sección 3 del manual.

**1** Retire los plásticos de embalaje de los enchufes (2 o 4).

**2** Conecte la SALIDA DE PROCESO de ThermoFlex (A) a la entrada de líquidos de su aplicación. Conecte la ENTRADA DE PROCESO de ThermoFlex (B) a la salida de líquidos de su aplicación. Asegúrese de que las conexiones se han cerrado y fijado correctamente. Para los enfriadores refrigerados por aire, o nitrato de amonio, consulte el paso 4.

**3** Conecte la SALIDA DE LA INSTALACIÓN de ThermoFlex (A) a un depósito o retorno de agua a la instalación. Conecte la ENTRADA A LA INSTALACIÓN de ThermoFlex (B) a un depósito de agua. Asegúrese de que las conexiones se han cerrado y fijado correctamente.

**4** Consulte la placa identificativa de la parte posterior del enfriador y compruebe la tensión apropiada. Para los enfriadores que se suministran con un cable de alimentación, inserte el extremo hembra del cable de alimentación en el enfriador y, a continuación, inserte el extremo macho del cable de alimentación en la toma eléctrica (el cable de alimentación se ubica debajo de la tapa de la caja de transporte. No deseches la tapa hasta que haya encontrado el cable).

**5** Si se selecciona el modo de funcionamiento de alta temperatura, consulte la sección 3 del manual.

**6** Nunca ponga en marcha el chiller sin líquido refrigerante en el tanque o sin la bolsa de filtro instalada.

**7** Lentamente rellene el depósito con líquido de proceso limpio (consulte la tabla 1). Utilice el tubo de control de nivel para controlar con facilidad el nivel de líquido. Cuando el depósito esté lleno, vuelva a colocar el tapón del depósito y apriételo a mano. Ya que la presión del depósito puede ser pequeña para la aplicación de que se trate y posiblemente deba purgar el aire de los tubos, tenga a mano líquido extra para mantener el sistema lleno al máximo nivel de líquido de proceso.

**8** Pulse el botón de inicio.

**9** En el controlador de modo de funcionamiento de alta temperatura, consulte la sección 3 del manual.

**1** Retire los plásticos de embalaje de los enchufes (2 o 4).

**2** Conecte la SALIDA DE PROCESO de ThermoFlex (A) a la entrada de líquidos de su aplicación. Conecte la ENTRADA DE PROCESO de ThermoFlex (B) a la salida de líquidos de su aplicación. Asegúrese de que las conexiones se han cerrado y fijado correctamente. Para los enfriadores refrigerados por aire, o nitrato de amonio, consulte el paso 4.

**3** Conecte la SALIDA DE LA INSTALACIÓN de ThermoFlex (A) a un depósito o retorno de agua a la instalación. Conecte la ENTRADA A LA INSTALACIÓN de ThermoFlex (B) a un depósito de agua. Asegúrese de que las conexiones se han cerrado y fijado correctamente.

**4** Consulte la placa identificativa de la parte posterior del enfriador y compruebe la tensión apropiada. Para los enfriadores que se suministran con un cable de alimentación, inserte el extremo hembra del cable de alimentación en el enfriador y, a continuación, inserte el extremo macho del cable de alimentación en la toma eléctrica (el cable de alimentación se ubica debajo de la tapa de la caja de transporte. No deseches la tapa hasta que haya encontrado el cable).

**5** Si se selecciona el modo de funcionamiento de alta temperatura, consulte la sección 3 del manual.

**6** Nunca ponga en marcha el chiller sin líquido refrigerante en el tanque o sin la bolsa de filtro instalada.

**7** Lentamente rellene el depósito con líquido de proceso limpio (consulte la tabla 1). Utilice el tubo de control de nivel para controlar con facilidad el nivel de líquido. Cuando el depósito esté lleno, vuelva a colocar el tapón del depósito y apriételo a mano. Ya que la presión del depósito puede ser pequeña para la aplicación de que se trate y posiblemente deba purgar el aire de los tubos, tenga a mano líquido extra para mantener el sistema lleno al máximo nivel de líquido de proceso.

**8** Pulse el botón de inicio.

**9** En el controlador de modo de funcionamiento de alta temperatura, consulte la sección 3 del manual.

**1** Retire los plásticos de embalaje de los enchufes (2 o 4).

**2** Conecte la SALIDA DE PROCESO de ThermoFlex (A) a la entrada de líquidos de su aplicación. Conecte la ENTRADA DE PROCESO de ThermoFlex (B) a la salida de líquidos de su aplicación. Asegúrese de que las conexiones se han cerrado y fijado correctamente. Para los enfriadores refrigerados por aire, o nitrato de amonio, consulte el paso 4.

**3** Conecte la SALIDA DE LA INSTALACIÓN de ThermoFlex (A) a un depósito o retorno de agua a la instalación. Conecte la ENTRADA A LA INSTALACIÓN de ThermoFlex (B) a un depósito de agua. Asegúrese de que las conexiones se han cerrado y fijado correctamente.

**4** Consulte la placa identificativa de la parte posterior del enfriador y compruebe la tensión apropiada. Para los enfriadores que se suministran con un cable de alimentación, inserte el extremo hembra del cable de alimentación en el enfriador y, a continuación, inserte el extremo macho del cable de alimentación en la toma eléctrica (el cable de alimentación se ubica debajo de la tapa de la caja de transporte. No deseches la tapa hasta que haya encontrado el cable).

**5** Si se selecciona el modo de funcionamiento de alta temperatura, consulte la sección 3 del manual.

**6** Nunca ponga en marcha el chiller sin líquido refrigerante en el tanque o sin la bolsa de filtro instalada.

**7** Lentamente rellene el depósito con líquido de proceso limpio (consulte la tabla 1). Utilice el tubo de control de nivel para controlar con facilidad el nivel de líquido. Cuando el depósito esté lleno, vuelva a colocar el tapón del depósito y apriételo a mano. Ya que la presión del depósito puede ser pequeña para la aplicación de que se trate y posiblemente deba purgar el aire de los tubos, tenga a mano líquido extra para mantener el sistema lleno al máximo nivel de líquido de proceso.

**8** Pulse el botón de inicio.

**9** En el controlador de modo de funcionamiento de alta temperatura, consulte la sección 3 del manual.

**5** Si se selecciona el modo de funcionamiento de alta temperatura, consulte la sección 3 del manual.

**6** Nunca ponga en marcha el chiller sin líquido refrigerante en el tanque o sin la bolsa de filtro instalada.

**7** Lentamente rellene el depósito con líquido de proceso limpio (consulte la tabla 1). Utilice el tubo de control de nivel para controlar con facilidad el nivel de líquido. Cuando el depósito esté lleno, vuelva a colocar el tapón del depósito y apriételo a mano. Ya que la presión del depósito puede ser pequeña para la aplicación de que se trate y posiblemente deba purgar el aire de los tubos, tenga a mano líquido extra para mantener el sistema lleno al máximo nivel de líquido de proceso.

**8** Pulse el botón de inicio.

**9** En el controlador de modo de funcionamiento de alta temperatura, consulte la sección 3 del manual.

**5** Si se selecciona el modo de funcionamiento de alta temperatura, consulte la sección 3 del manual.

**6** Nunca ponga en marcha el chiller sin líquido refrigerante en el tanque o sin la bolsa de filtro instalada.

**7** Lentamente rellene el depósito con líquido de proceso limpio (consulte la tabla 1). Utilice el tubo de control de nivel para controlar con facilidad el nivel de líquido. Cuando el depósito esté lleno, vuelva a colocar el tapón del depósito y apriételo a mano. Ya que la presión del depósito puede ser pequeña para la aplicación de que se trate y posiblemente deba purgar el aire de los tubos, tenga a mano líquido extra para mantener el sistema lleno al máximo nivel de líquido de proceso.

**8** Pulse el botón de inicio.

**9** En el controlador de modo de funcionamiento de alta temperatura, consulte la sección 3 del manual.

**5** Si se selecciona el modo de funcionamiento de alta temperatura, consulte la sección 3 del manual.

**6** Nunca ponga en marcha el chiller sin líquido refrigerante en el tanque o sin la bolsa de filtro instalada.

**7** Lentamente rellene el depósito con líquido de proceso limpio (consulte la tabla 1). Utilice el tubo de control de nivel para controlar con facilidad el nivel de líquido. Cuando el depósito esté lleno, vuelva a colocar el tapón del depósito y apriételo a mano. Ya que la presión del depósito puede ser pequeña para la aplicación de que se trate y posiblemente deba purgar el aire de los tubos, tenga a mano líquido extra para mantener el sistema lleno al máximo nivel de líquido de proceso.

**8** Pulse el botón de inicio.

**9** En el controlador de modo de funcionamiento de alta temperatura, consulte la sección 3 del manual.

**5** Si se selecciona el modo de funcionamiento de alta temperatura, consulte la sección 3 del manual.

**6** Nunca ponga en marcha el chiller sin líquido refrigerante en el tanque o sin la bolsa de filtro instalada.

**7** Lentamente rellene el depósito con líquido de proceso limpio (consulte la tabla 1). Utilice el tubo de control de nivel para controlar con facilidad el nivel de líquido. Cuando el depósito esté lleno, vuelva a colocar el tapón del depósito y apriételo a mano. Ya que la presión del depósito puede ser pequeña para la aplicación de que se trate y posiblemente deba purgar el aire de los tubos, tenga a mano líquido extra para mantener el sistema lleno al máximo nivel de líquido de proceso.

**8** Pulse el botón de inicio.

**9** En el controlador de modo de funcionamiento de alta temperatura, consulte la sección 3 del manual.

**Tabla 1: Líquidos aprobados**

El uso de cualquier otro líquido anula la garantía del fabricante.

**Enfriadores de temperatura estándar**

- Agua filtrada/destilada (pH 7 - 8)
- Agua desionizada (1 - 3 MΩ-cm, compensada)
- Agua destilada con inhibidor y biocida Nalco
- Agua destilada con cloro (5 ppm)
- Agua/etilenglicol para laboratorio al 0 - 75 %
- Agua/propilenglicol para laboratorio al 0 - 75 %

**Enfriadores de alta temperatura**

- Agua filtrada (pH 7 - 8)\*
- Agua/etilenglicol para laboratorio al 0 - 50%
- Agua/propilenglicol para laboratorio al 0 - 50%
- \*hasta 88 °C para enfriadores con bombas P1 y P2
- \*hasta 82 °C para ThermoFlex24000 con bomba T9
- \*hasta 90 °C para enfriadores con otras bombas

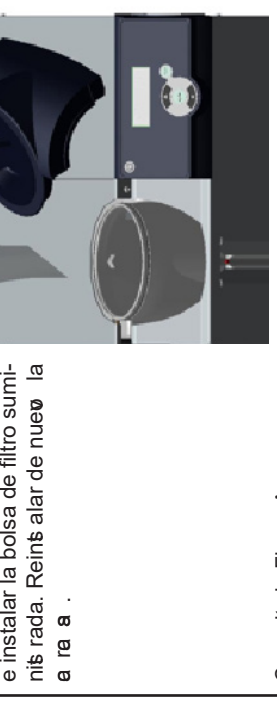
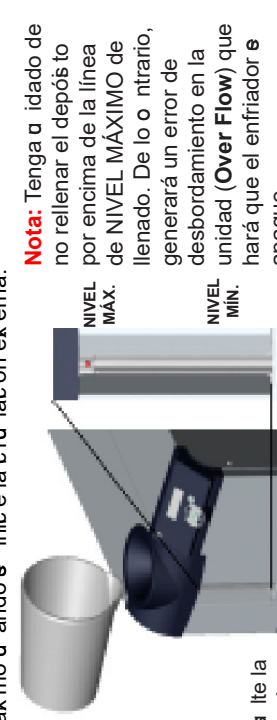
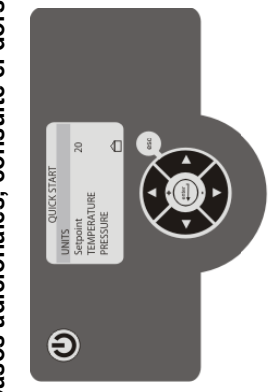

Consulte la Figura A.

Consulte la Figura A.

Consulte la Figura A.

Consulte la Figura B.



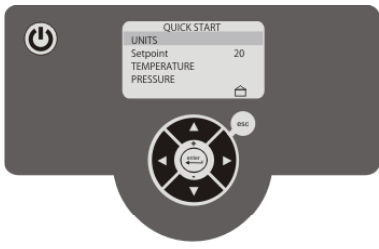

QUICK START	
<b>UNITS</b>	
<b>Setpoint</b>	<b>20</b>
<b>TEMPERATURE</b>	
<b>PRESSURE</b>	
<b>FLUID LEVEL</b>	
<b>AUTO REFILL*</b>	
<b>FLOW*</b>	
<b>Line Frequency*</b>	<b>60HZ</b>
<input type="checkbox"/> <b>Auto Restart</b>	
<input type="checkbox"/> <b>Audible Alarms</b>	
<b>RA FAN SPEED MODE*</b>	
<b>Care Level</b>	<b>Off</b>
<b>SERIAL COMM - DCOM*</b>	
<b>ANALOG COMM - ACOM*</b>	
<b>RESISTIVITY*</b>	
<b>mm/dd/yy</b>	<b>hh:mm:ss</b>
<b>◀ Quick Start Done (Finalización de la puesta en marcha rápida)</b>	
*Se muestra solo en los enfriadores equipados con esta opción.	

**NOTA:** Se puede modificar la configuración de cualquiera de los parámetros una vez que el enfriador comienza a funcionar.

En el controlador se lo pueden mostrar en las líneas del menú QUICK START (PUESTA EN MARCHA RÁPIDA) al mismo tiempo.

**Utilice la flecha abajo para desplazarse y resaltar las líneas. En caso de que se requiera cambiar alguno de los parámetros predeterminados,**

**resalte la línea que desea modificar y pulse el botón Enter (Intro).**

Si el texto del parámetro es á es ito o n letras mayú s las el parámetro tendrá un menú secundario. Si pulsa el botón Enter (Intro), aparecerá el menú secundario. Los menús e ndarios le permiten i s aliz r/ cambiar los valores correspondientes.

Después de pulsar el botón Enter (Intro), la línea comenzará a parpadear, lo que indicará que el valor puede cambiarse con las flechas arriba/abajo. Cuando se muestre el valor que desea, pulse el botón Enter (Intro) para detener el parpadeo y aceptar el valor nuevo. Cuando haya realizado todos los cambios que desee, pulse la flecha izquierda o la tecla Esc para volver al menú QUICK START (Puesta en marcha rápida).

Si el enfriador muestra el valor de error predeterminado, se cerrará, en el controlador se mostrará un mensaje de error y, si está activada, se oír la alarma. Si el enfriador muestra el valor de alerta predeterminado, se continuará funcionando, en el controlador se mostrará un mensaje de alerta y, si está activada, se oír la alarma.

Las líneas en las que el texto no está escrito con letras mayúsculas indican que los cambios pueden hacerse directamente en el menú QUICK START (Puesta en marcha rápida) (por ejemplo, Setpoint [Valor de referencia] y Line Frequency [Frecuencia de línea]). Siga el mismo procedimiento para cambiar estos valores.

Si la línea tiene una casilla en blanco (por ejemplo, Auto Restart [Reinicio automático]), resalte la línea y pulse el botón Enter (Intro) para que la casilla se muestre de color negro. Una casilla negra indica que la función está activada. Vuelva a pulsar el botón Enter (Intro) para volver a poner en blanco la casilla. Una casilla en blanco indica que la función está desactivada.

Texto en pantalla	Indicación	Intervalo	Valor predeterminado
UNITS (UNIDADES)	Escalas de visualización de temperatura, presión y flujo del controlador. (La visualización del flujo es opcional).	C o F psi, bar o kPa gal/min o l/min	C psi gal/min
Setpoint (valor de referencia)	Valor de referencia.	De + 5 °C a + 40 °C (de + 5 °C a + 90 °C en enfriadores de alta temperatura)	+ 20 °C
TEMPERATURE (TEMPERATURA)	Valores de error y alerta de temperatura.	De + 2 °C a + 43 °C (+ 93 °C en enfriadores de alta temperatura) De -8 °C a + 93 °C para ThermoFlex24000	Superior: + 42 °C (+ 92 °C en enfriadores de alta temperatura) Inferior: + 3 °C -7 °C para ThermoFlex24000
PRESSURE (PRESIÓN)	Valores de error, alerta y tiempo de retardo de presión  (el tiempo de retardo es el periodo de tiempo que debe transcurrir para que el enfriador se apague tras un error de presión).	Según la bomba (consulte la tabla 1)  Tiempo de retardo: de 0 a 30 segundos	Según la bomba (consulte la tabla 1)  Tiempo de retardo superior: 0 segundos  (60 segundos con bombas P3 - P5)  Tiempo de retardo inferior: 10 segundos
FLUID LEVEL (NIVEL DE LÍQUIDO)	Valores de alerta y error de nivel bajo del depósito.	Según el calentador (consulte la tabla 3)	Según el calentador (consulte la tabla 3)
AUTO REFILL (RECARGA AUTOMÁTICA)	Valores de recarga automática opcionales. (ON [Activado] es el % de nivel de líquido que se necesita en el depósito para activar la recarga. Time Out (Tiempo de espera) es el tiempo máximo durante el cual funcionará la opción. Al establecer el tiempo en 0, se desactivará la opción).	Activado: del 70 % al 100 %  Tiempo de espera: de 0 a 900 segundos	Según el calentador; consulte el manual
FLOW (FLUJO)	Valores de alerta y error del flujo del líquido del proceso.	Según la bomba (consulte la tabla 2)	Según la bomba (consulte la tabla 2)
Line Frequency (Frecuencia de línea)	Frecuencia entrante (solo enfriadores con una bomba P3 - P5 y la capacidad de funcionar a 50 Hz o 60 Hz. La frecuencia seleccionada ajusta automáticamente la configuración predeterminada de presión alta fija del firmware).	50 Hz o 60 Hz	60 Hz
Auto Restart (Reinicio automático)	Activa el reinicio automático.	<input type="checkbox"/> o <input checked="" type="checkbox"/>	<input type="checkbox"/>
Audible Alarms (Alarmas sonoras)	Activa las alarmas sonoras.	<input type="checkbox"/> o <input checked="" type="checkbox"/>	<input type="checkbox"/>
RA FAN SPEED MODE (MODO RÁPIDO DE VELOCIDAD DE VENTILADOR)	Velocidad del ventilador. Solo para enfriadores refrigerados por aire ThermoFlex2500  (La opción Auto [Automático] permite que el ventilador funcione con las condiciones enumeradas en el manual; consulte la sección 3. La opción ON [Activado] permite que el ventilador funcione a alta velocidad todo el tiempo).	ON (Activado) o Auto (Automático)	Auto (Automático)
Care Level (Nivel de cuidados)	Recordatorio de la frecuencia de limpieza como cuidado preventivo de los filtros de aire y líquidos del enfriador.	Off (desactivado), 1 (1000 horas), 2 (2000 horas) 3 (3000 horas)	Off
SERIAL COMM - DCOM (COMUNICACIONES EN SERIE - DCOM)	Comunicaciones en serie opcionales (para obtener información adicional, consulte el manual).	Off (desactivado), RS232, RS485	Off (desactivado)
ANALOG COMM - ACOM (COMUNICACIONES ANALÓGICAS - ACOM)	Comunicaciones analógicas opcionales (para obtener información adicional, consulte el manual).	Consulte el manual.	
RESISTIVITY (RESISTIVIDAD)	Activa/configura la opción de resistividad (para obtener información adicional, consulte el manual).	<input type="checkbox"/> o <input checked="" type="checkbox"/> Valor de referencia: de 0,2 a 3,0 MΩ-cm Intervalo: de 0,1 a 0,5 MΩ-cm Alerta superior: de 0,0 a 3,5 MΩ-cm Alerta inferior: de 0,0 a 3,5 MΩ-cm	<input type="checkbox"/> Valor de referencia: 1,0 MΩ-cm Intervalo: 0,1 MΩ-cm Alerta superior: 3,0 MΩ-cm Alerta inferior: 0,5 MΩ-cm
mm/dd/yy (mm/dd/aa)	Establece la fecha. En algunos mensajes de error se muestra la fecha en la que se produjeron.		
hh:mm:ss	Establece la hora. En algunos mensajes de error se muestra la hora en la que se produjeron.		
Quick Start Done (Finalización de la puesta en marcha rápida)	Para finalizar el procedimiento de puesta en marcha rápida y guardar los cambios, pulse el botón Enter (Intro). Para salir de la puesta en marcha rápida y descartar los cambios, pulse la flecha izquierda o pulse el botón Esc. En ambos casos, la pantalla se quedará en blanco.		

Tabla 1	Intervalo de error	Valor predet. superior	Valor predet. inferior
<b>Bombas T0 T1 P1 P2:</b>	De 3 a 105 PSI	105 PSI	3 PSI
<b>Bombas T5:</b>	De 2 a 105 PSI	105 PSI	4 PSI
<b>Bombas P3 P4 P5:</b>	Consulte el manual	Consulte el manual	4 PSI
<b>Bombas T9:</b>	De 3 a 105 PSI	105 PSI	3 PSI

Tabla 2	Intervalo	Valor predet. superior	Valor predet. inferior
<b>Bombas T0 T1 P1 P2:</b>	De 0,0 a 10,5 GPM	0,0 GPM	0,0 GPM
<b>Bombas T5:</b>	De 0,0 a 15,0 GPM	0,0 GPM	0,0 GPM
<b>Bombas P3 P4 P5:</b>	De 0,0 a 30,0 GPM	0,0 GPM	0,0 GPM
<b>Bombas T9:</b>	De 0,0 a 33,5 GPM	0,0 GPM	0,0 GPM

Tabla 3	Intervalo de alerta	Valor predeterminado
<b>Calentador Ninguno</b>	Del 6 al 100 %	6 %
<b>1 kW:</b>	Del 58 al 100 %	58 %
<b>2,3 kW:</b>	Del 58 o 69 al 100 %	58 o 69 %
<b>5,0 kW:</b>	Del 87 al 100 %	87 %
<b>4,6 kW:</b>	Del 87 al 100 %	87 %

Tabla 3	Intervalo de error	Valor predeterminado
<b>Calentador Ninguno</b>	Del 0 al 100 %	0 %
<b>1 kW:</b>	Del 52 al 100 %	52 %
<b>2,3 kW:</b>	Del 52 o 63 al 100 %	52 o 63 %
<b>5,0 kW:</b>	Del 81 al 100 %	81 %
<b>4,6 kW:</b>	Del 81 al 100 %	81 %

# Preface

## Compliance Third Party:

Designed to comply and listed/certified to:

UL 61010-1:2012, Third Edition

CAN/CSA-C22.2 No.61010-1-12, Third Edition



## European Union ( EU )

The Declaration of Conformity is located in the back of this manual.

## WEEE

This product is required to comply with the European Union's Waste Electrical & Electronic Equipment (WEEE) Directive 2012/19/EU. It is marked with 'wheelie bin' symbol.



Thermo Fisher Scientific has contracted with one or more recycling/ disposal companies in each EU Member State, dispose of or recycle this product through them. Further information on Thermo Fisher Scientific's compliance with these Directives is available at [www.thermofisher.com/WEEERoHS](http://www.thermofisher.com/WEEERoHS)

## After-sale Support

Thermo Fisher Scientific is committed to customer service both during and after the sale. If you have questions concerning the chiller operation, or questions concerning spare parts or Service Contracts, call our Sales, Service and Customer Support phone number, see this manual's inside cover for contact information.

When calling, please refer to the labels on the inside cover. These labels list all the necessary information needed to properly identify your chiller.

## Feedback

We appreciate any feedback you can give us on this manual. Please e-mail us at [tcmanuals@thermofisher.com](mailto:tcmanuals@thermofisher.com). Be sure to include the manual part number and the revision date listed on the front cover.

## Warranty

Thermo Scientific ThermoFlex chillers have a warranty against defective parts and workmanship for 24 months (**excluding MD1/MD2 Magnetic Drive and P1/P2 Positive Displacement pumps which are warranted for 12 months**) from date of shipment. See back page for more details.

## Unpacking

If the chiller has a line cord it is located under the shipping crate's lid. Do not discard the lid until the cord is located.

Locate the reservoir fluid filter bag and ensure it installed before the chiller is operated. See Section 3.

Retain all cartons and packing material until the chiller is operated and found to be in good condition. If it shows external or internal damage contact the transportation company and file a damage claim. Under ICC regulations, this is your responsibility.

### Out of Box Failure

An Out of Box Failure is defined as any product that fails to operate in conformance with sellers published specifications at initial power up. Install the chiller in accordance with manufacturer's recommended operating conditions within 30 days of shipment from the seller.

Any Temperature Control product meeting the definition of an Out of Box Failure must be packed and shipped back in the original packaging to Thermo Fisher Scientific for replacement with a new chiller; seller to pay the cost of shipping. Customer must receive a Return Material Authorization (RMA) from Thermo Fisher prior to shipping.

# Section 1 Safety

## Safety Warnings

Make sure you read and understand all instructions and safety precautions listed in this manual before installing or operating your chiller. If you have any questions concerning the operation or the information in this manual, please contact us. See inside cover for contact information.



**DANGER** indicates an imminently hazardous situation which, if not avoided, *will* result in death or serious injury.



**WARNING** indicates a potentially hazardous situation which, if not avoided, *could* result in death or serious injury.



**CAUTION** indicates a potentially hazardous situation which, if not avoided, may result in minor or moderate injury. It is also be used to alert against unsafe practices.



The lightning flash with arrow symbol, within an equilateral triangle, is intended to alert the user to the presence of non-insulated "dangerous voltage" within the chiller's enclosure. The voltage magnitude is significant enough to constitute a risk of electrical shock.



This label indicates read the manual.

**Performance of installation, operation, or maintenance procedures other than those described in this manual may result in a hazardous situation and may void the manufacturer's warranty and safety compliance. ▲**

**Observe and never remove warning labels. ▲**

**Never place the chiller in a location where excessive heat, moisture, or corrosive materials are present. ▲**

**The chiller's construction provides protection against the risk of electrical shock by grounding appropriate metal parts. The protection will not function unless the power cord is connected to a properly grounded outlet. It is the user's responsibility to assure a proper ground connection is provided. ▲**

**Never operate equipment with damaged power cords. ▲**

**The circuit protector located on the rear is not intended to act as a disconnecting means. ▲**

**Never operate the chiller with panels removed. ▲**

**Never operate the chiller without process fluid in the reservoir. ▲**

**Never connect the process fluid inlet or outlet fittings to your building water supply or any water pressure source. ▲**

**Before using any fluid or performing maintenance where contact with the fluid is likely refer to the manufacturer's SDS for handling precautions. ▲**

**To prevent freezing/glazing of the plate exchanger, ThermoFlex7500 through ThermoFlex24000 chillers require the use of 50/50 EG/water or 50/50 PG/water below 10°C process temperature. ▲**

**When using a process fluid mixture of ethylene glycol and water or propylene glycol and water, check the fluid concentration and pH on a regular basis. Changes in concentration and pH can impact system performance. See Section 3. ▲**

**Do not use automotive antifreeze. Commercial antifreeze contains silicates that can damage the pump seals. Use of automotive antifreeze will void the manufacturer's warranty. ▲**

**Many refrigerants which may be undetectable by human senses are heavier than air and will replace the oxygen in an enclosed area causing loss of consciousness. Contact with leaking refrigerant will cause skin burns. Refer to the chiller's nameplate for the type of refrigerant used and then the refrigerant's SDS for additional information. ▲**

**Drain the chiller before it is transported and/or stored, see Draining in Section 8. Store the chiller in the temperature range -25°C to 60°C (with packaging), and <80% relative humidity. ▲**

**Always turn off the chiller and disconnect the power cord from the power source before performing any service or maintenance procedures, or before moving. ▲**

**Transport the chiller with care. Sudden jolts or drops can damage its components. ▲**

**Never operate damaged or leaking equipment. ▲**

**Refer service and repairs to a qualified technician. ▲**



很多人感觉无法察觉的制冷剂可能要比空气重，在封闭区域中将取代氧气，从而导致人失去意识。接触泄漏的制冷剂将会导致皮肤灼伤。请参阅冷却器的铭牌了解其所用的制冷剂类型，并通过查阅制冷剂 SDS 了解更多信息。

**安全警告**  
安装或操作冷却器前，请确保阅读和理解本手册中所列的所有说明和安全预防措施。如果对本手册中的操作或信息存在疑问，请联系我们。有关联系信息，请见内封面。



“危险”表示如不避免，将导致死亡或重伤的紧急危险情况。



“警告”表示如不避免，可能导致死亡或重伤的潜在危险情况。



“小心”表示如不避免，可能导致轻伤或中度损伤的潜在危险情况。其还用于对不安全的做法发出警报。



等边三角形中带箭头的闪电符号用于警告用户冷却器外壳中存在非绝缘“危险电压”。电压幅度足以产生触电风险。



该标签表示需要阅读手册。

不遵循本手册所述的安装、操作或维护程序可能会导致危险情况，并使制造商的保修和安全合规性失效。

请遵循警告标签，切勿将其取下。

请勿将冷却器放在过热、过湿或存在腐蚀性材料的场所。

冷却器结构通过对相应的金属部件进行接地来避免触电风险。如果电源线未连接到正确接地的插座，将无法发挥保护作用。用户应负责提供正确的接地连接。

请勿操作电源线损坏的设备。

对于 ThermoFlex900-10000 冷却器，位于后部的电路保护器不用于断开连接。

请勿在取下面板的情况下操作冷却器。

请勿在储液罐中没有处理液的情况下操作冷却器。

请勿将处理液入口或出口接头连接到建筑物供水或水压源。

在使用任何液体或执行任何可能需要接触液体的维护之前，请参阅制造商的 SDS 了解处理时的注意事项。

为避免板式换热器冻结/太过光滑，ThermoFlex7500 至 ThermoFlex24000 冷却器需要在处理温度低于 10°C 时使用 50/50 EG/水或 50/50 PG/水。

使用乙二醇与水或丙二醇与水的混合处理液时，请定期检查液体浓度和 pH 值。浓度和 pH 值的变化可能会影响系统性能。请参见第 3 节。

请勿使用汽车防冻液。市售防冻液含有可能会损坏泵密封件的硅酸盐。使用汽车防冻液将导致制造商保修失效。

在运输和/或存放冷却器之前，请先对其进行排空，请参见第 8 节中的“排放”。冷却器应存放在温度为 -25°C 至 60°C（带包装），相对湿度 <80% 的环境。

执行维修或维护程序或进行移动之前，请务必关闭冷却器，并将电源线与电源断开。

运输冷却器时，请务必小心。突然的摇晃或掉落可能会损坏其组件。

请勿操作损坏或泄漏的设备。

请由获得相应资质的技术人员执行维修。



## Grundlegende Sicherheitsanweisungen Umwälzkühler

Falls Sie eine dieser Anweisungen nicht verstehen, lesen Sie das Handbuch oder kontaktieren Sie uns bevor Sie fortfahren.

### Sicherheit, alle Produkte:

**DANGER** weist auf eine unmittelbar gefährliche Situation hin, die, falls sie nicht vermieden wird, zum Tod oder schweren Verletzungen führt.

**WARNING** weist auf eine potenziell gefährliche Situation hin, die zu ernsthaften Verletzungen oder zum Tod führen kann, wenn sie nicht vermieden wird.

**CAUTION** weist auf eine potenziell gefährliche Situation hin, die, falls sie nicht vermieden wird, zu leichteren bis mittelschweren Verletzungen führen kann. Es kann auch verwendet werden, um gegen unsichere Praktiken zu warnen.

 ist dafür vorgesehen, den Benutzer vor dem Bestehen einer nicht isolierten "gefährlichen Spannung" im Gehäuse des Kühlers zu warnen. Die Höhe der Spannung ist bedeutend genug, sodass ein Stromschlag-Risiko besteht.

 weist auf das Vorhandensein heißer Oberflächen hin.

 weist darauf hin, das Handbuch zu lesen.

Benutzen Sie das Gerät keinesfalls als steriles oder an Patienten angeschlossenes Gerät. Außerdem ist das Gerät nicht für den Gebrauch an Orten mit Gefahrenklasse I, II oder III, wie in den nationalen Vorgaben für elektrische Geräte definiert, ausgelegt.

Das Gerät ist nur für den Gebrauch in Innenräumen ausgelegt. Stelle Sie es niemals an einen Ort wo übermäßige Temperaturen, Feuchtigkeit, unzureichende Belüftung oder korrosive Materialien vorhanden sind. Lesen Sie im Benutzerhandbuch über die Betriebsparameter.

Schließen Sie das Gerät an eine vorschriftsmäßig geerdete Steckdose an.

Die verwendeten Kühlmittel sind schwerer als Luft und werden im Fall einer Leckage den Sauerstoff ersetzen, was zu Bewusstlosigkeit führt. Kontakt mit auslaufendem Kühlmittel führt zu Hautverbrennungen. Den Typ des verwendeten Kühlmittels entnehmen Sie dem Namensschild des Zirkulators und zusätzliche Informationen dem neuesten US Sicherheitsdatenblatt (SDS) des Herstellers, vormals MSDS, und dem EU Sicherheitsdatenblatt.

Transportieren Sie das Gerät mit Sorgfalt. Plötzliche Stöße oder das Herabfallen können seine Komponenten beschädigen. Schalten Sie vor dem Verschieben das Gerät immer ab und trennen Sie es von der Versorgungsspannung.

Betreiben Sie niemals beschädigte oder undichte Geräte.

Verwenden Sie niemals entzündbare oder korrosive Flüssigkeiten. Benutzen Sie nur zugelassene Flüssigkeiten, die in diesem Handbuch aufgelistet sind. Entnehmen Sie vor der Verwendung einer zugelassenen Flüssigkeit oder vor Wartungsarbeiten, bei denen der Kontakt mit der Flüssigkeit wahrscheinlich ist, zusätzliche Informationen dem neuesten US Sicherheitsdatenblatt (SDS) oder dem EU Sicherheitsdatenblatt.

Schalten Sie vor dem Verschieben das Gerät immer ab und trennen Sie es von der Versorgungsspannung.

Lassen Sie die Instandhaltung und Reparaturen von einem qualifizierten Techniker durchführen.

Lagern Sie das Gerät bei Temperaturen von -25°C bis 60°C (mit Packung), und bei einer relativen Feuchtigkeit < 80%.

Die Außerbetriebnahme darf nur von einem Fachhändler unter Verwendung zertifizierter Ausrüstung durchgeführt werden. Alle einschlägigen Vorschriften müssen befolgt werden.

Die Ausführung von Installations-, Betriebs- oder Wartungsprozeduren, außer den im Handbuch beschriebenen, kann zu einer gefährlichen Situation führen und macht die Herstellergarantie ungültig. Legen Sie niemals Netzspannung an einen der Kommunikationsanschlüsse am Kühler an.

Werden der Kühler und die Prozessflüssigkeitsleitungen nicht komplett aufgefüllt, könnte dies die Pumpe des Kühlers beschädigen. Vermeiden Sie eine Überfüllung, Flüssigkeiten dehnen sich bei Erwärmung aus.

Stellen Sie beim ThermoFlex vor dem Austausch des Behältergehäuses sicher, dass die Sichtrohr-Kugelabspernung sicher in Stellung ist.

Betreiben Sie beim ThermoFlex900-5000 den Kühler nicht, wenn der Behälterflüssigkeitsdiffusor nicht installiert ist.

Falls Ihr Kühler mit einer Druckpumpe (P1 oder P2) ausgestattet ist, stellen Sie sicher, dass die Rohranschlussleitungen und Armaturen Ihrer Anwendung so ausgelegt sind, dass sie eine Mindestlast von 185 psi aushalten.

Kein Frostschutzmittel für Autos verwenden. Handelsübliche Frostschutzmittel enthalten Silikate, welche die Pumpendichtungen beschädigen.

Um das Entfrieren/die Verglasung des Platten-Wärmetauschers zu verhindern, müssen

ThermoFlex7500-24000 Kühler mit 50/50 EG/Wasser oder 50/50 PG/Wasser bei einer Prozesstemperatur unter 10°C betrieben werden.

Prüfen Sie beim Gebrauch einer Prozessflüssigkeitsmischung aus EG/Wasser oder PG/Wasser, regelmäßig die Konzentration und den pH-Wert der Flüssigkeit. Änderungen der Konzentration und des pH-Wertes können die Leistung des Systems beeinträchtigen. Verwenden Sie keine Entionisierungsfilterspatrone (DI)

mit inhibiertem EG oder inhibiertem PG. Ein DI-Filter entfernt die Inhibitoren aus der Lösung, wodurch die Flüssigkeit wirklos gegen Korrosionsschutz wird. Inhibitoren können auch die Leitfähigkeit der Flüssigkeit erhöhen.

Sie sind schädlichen wenn man sie einatmet, schluckt oder durch die Haut absorbiert. Lesen Sie das neueste SDS des Herstellers.

Um Schäden am Platten-Wärmetauscher des Kühlers zu vermeiden, müssen Kreiselumpen mit einer Mindestdurchflussrate 4.0 gpm (15.1 lpm) betrieben werden. Wird der Kondensatorfilter nicht gereinigt/ersetzt, führt das zu einem Verlust der Kühlleistung und zu einem vorzeitigen Kühlsystemausfall.

Entfernen Sie zur gründlichen Reinigung die Frontgitter-Baugruppe. Bei luftgekühlten Kühler sind die Umrahmung und Rippen des Kondensators, die sich hinter der Frontgitter-Baugruppe befinden, sehr scharfkantig.

Außer im Fall der luftgekühlten Gitter-Baugruppe, darf der Kühler keinesfalls mit einer entfernten Seitenwand betrieben werden.

ThermoFlex900-5000 wassergekühlte Kühler haben einen Ventilator mit scharfen Kanten, stellen Sie deshalb sicher, dass der Kühler abgeschaltet ist, bevor Sie das Frontgitter abnehmen.

## Verwendungszweck, Umwälzungskühler:

Umwälzungskühler von Thermo Scientific sind so konstruiert, dass sie einen kontinuierlichen Zulauf der Flüssigkeit bei konstanter Temperatur und Durchflussrate ermöglicht. Der Kühler besteht aus einem luft- und wassergekühlten Kühlsystem, Wärmetauscher, Umwälzpumpe, Prozesssicherheitsbehälter und einem Mikroprozessor-Steuergerät.

Die Kühler sind für den Dauerbetrieb und den Innengebrauch unter Einhaltung aller in diesem Handbuch angegebenen Prozeduren und Anforderungen konstruiert.

## Installation, Umwälzungskühler:

Platzieren Sie den Kühler so, dass er in der Nähe seiner Trennvorrichtung ist, und leichten Zugang zu diesem hat.

Der Kühler ist für den Gebrauch an einer speziellen Steckdose vorgesehen.

Stellen Sie sicher, dass alle Rohrleitungstransportstecker vor der Installation entfernt werden.

Die Anschlüsse für Prozessflüssigkeit befinden sich auf der Rückseite des Kühlers und sind mit  (PROCESS OUTLET (PROZESSAUSLASS)) und  (PROCESS INLET (PROZESSEINLASS)) gekennzeichnet. Schließen Sie  an den Flüssigkeitseinlass Ihrer Anwendung an. Schließen Sie  an den Flüssigkeitsauslass Ihrer Anwendung an.

Schließen Sie bei wassergekühlten Kühlern den  (FACILITY INLET (ANLAGENEINLASS)) an Ihre Leitungswasserversorgung. Schließen Sie den  (FACILITY OUTLET (ANLAGENAUSLASS)) an Ihren Leitungswasserrücklauf oder -Abfluss.

Bevor Sie den Kühler starten, führen Sie eine Doppelkontrolle aller Kommunikations-, elektrischen und Rohranschlüssen.

## Consignes de sécurité Refrigidisseurs à recirculation

Si vous ne comprenez pas l'une de ces instructions, reportez-vous au manuel ou contactez-nous avant d'effectuer une opération.

### Sécurité, tous les produits :

 indique une situation de danger imminent qui, si elle n'est pas évitée, peut entraîner une blessure grave ou mortelle.

 indique une situation de danger potentiel qui, si elle n'est pas évitée, pourrait entraîner une blessure grave ou mortelle.

 indique une situation de danger potentiel qui, si elle n'est pas évitée, peut entraîner une blessure légère à modérée. Ce symbole est également utilisé pour mettre en garde contre des pratiques dangereuses.

 ce symbole avertit l'utilisateur de la présence d'une « tension dangereuse » non isolée dans l'enceinte du réfrigérant. La magnitude de la tension est suffisante pour constituer un risque d'électrocution.

 indique la présence de surfaces chaudes.

 indique qu'il convient de lire le manuel.

N'utilisez pas l'équipement comme appareil stérile ou relié au patient. En outre, l'équipement n'est pas prévu pour une utilisation dans des emplacements dangereux de classe I, II ou III, tels que définis par le National Electrical Code.

Il est conçu pour l'usage intérieur exclusivement. Ne placez jamais l'équipement dans un endroit présentant un excès de chaleur, d'humidité, une ventilation inadaptée ou des matériaux corrosifs. Reportez-vous au manuel pour connaître les paramètres de fonctionnement.

Branchez l'équipement sur une prise correctement mise à la terre.

Les réfrigérants utilisés sont plus lourds que l'air. En cas de fuite, ils chassent l'oxygène et provoquent une perte de connaissance. Tout contact avec la fuite de réfrigérant peut causer des brûlures cutanées. Reportez-vous à la plaque signalétique du circulateur pour connaître le type de réfrigérant utilisé. Lisez également la fiche de données de sécurité (SDS, anciennement MSDS) américaine la plus récente

du fabricant ainsi que la fiche de données de sécurité européenne pour obtenir des informations complémentaires.

Déplacez l'équipement avec précaution. Les secousses ou les chutes peuvent endommager les composants. Éteignez l'équipement et débranchez la tension d'alimentation de sa source avant de le déplacer.

Ne faites jamais fonctionner un équipement endommagé ou qui fuit.

N'utilisez jamais des liquides inflammables ou corrosifs. Utilisez uniquement les liquides approuvés cités dans le manuel. Avant d'utiliser un liquide ou de procéder à une opération de maintenance pouvant comporter un contact avec le liquide, reportez-vous aux fiches de données de sécurité du fabricant et de l'Union européenne pour obtenir des informations complémentaires.

Éteignez l'équipement et débranchez-le de sa tension d'alimentation avant de le déplacer.

Confiez les entretiens et réparations à un technicien qualifié.

Stockez l'équipement à une température comprise entre 25°C et 60°C (avec l'emballage), et sous une humidité relative <80%.

La mise hors service doit être effectuée par un revendeur qualifié à l'aide d'un équipement certifié. Toutes les réglementations en vigueur doivent être respectées.

L'exécution des procédures d'installation, de fonctionnement ou de maintenance autres que celles décrites dans le manuel peut créer une situation dangereuse et annuler la garantie du fabricant.

Ne mettez jamais les raccordements de communications du réfrigérant sous tension.

Si vous ne remplissez pas complètement le réfrigérant et les conduites de liquide, vous risquez d'endommager la pompe. Évitez de trop remplir le réservoir car les liquides se dilatent lorsqu'ils sont chauffés.

Sur le ThermoFlex, avant de remplacer le boîtier du réservoir, vérifiez que le bouchon à bille du tube de regard du réservoir est correctement mis en place.

Sur ThermoFlex900-5000, ne faites pas fonctionner le réfrigérant si le diffuseur de liquide du réservoir est installé.

Si votre réfrigérant est équipé d'une pompe volumétrique (P1 ou P2), vérifiez que les conduites et les raccords de votre application peuvent résister à 185 psi.

N'utilisez pas d'antigel automobile. Les antigels commerciaux contiennent des silicates qui endommagent les joints de la pompe.

Pour éviter la congélation/le givrage de l'échangeur à plaques, les réfrigérants ThermoFlex7500-24000 nécessitent l'utilisation d'un mélange à part égale d'éthylène glycol et d'eau ou de propylène glycol et d'eau à une température de fonctionnement inférieure à 10°C.

Si vous utilisez un mélange d'éthylène glycol et d'eau ou de propylène glycol et d'eau, vérifiez régulièrement sa concentration et son pH. Les changements de concentration et de pH peuvent avoir une influence sur les performances du système.

N'utilisez pas de cartouche à filtre de désionisation (DI) avec de l'éthylène glycol inhibé ou du propylène glycol inhibé. Un filtre DI éliminera les inhibiteurs de la solution et rendra le liquide inefficace contre la protection anti-corrosion. De même, les inhibiteurs augmentent la conductivité du liquide.

Les biocides sont corrosifs et peuvent causer des lésions oculaires irréversibles ainsi que des brûlures cutanées. Ils sont nocifs s'ils sont inhalés, avalés ou absorbés par la peau.

Reportez-vous à la fiche de données de sécurité la plus récente du fabricant.

Pour éviter d'endommager l'échangeur à plaques du refroidisseur, les pompes centrifugeuses nécessitent un débit minimum de 15,1 l/min.

Le non-nettoyage ou non-remplacement du filtre du condenseur peut causer une perte de capacité de refroidissement et entraîner une panne prématurée du système de refroidissement. Pour un nettoyage complet, déposez la grille avant.

Sur les refroidisseurs à air, le boîtier du condenseur et les ailettes situés derrière la grille avant sont très tranchants.

Hormis la grille refroidie à l'air, ne faites jamais fonctionner le refroidisseur si l'un des panneaux est déposé.

Les refroidisseurs à eau ThermoFlex900-5000 sont dotés d'un ventilateur dont les hélices sont tranchantes. Vérifiez que le refroidisseur est éteint avant de déposer la grille avant.

### Utilisation prévue des refroidisseurs à recirculation

Les refroidisseurs à recirculation de Thermo Scientific sont conçus pour fournir du liquide en continu à une température et selon un débit constants. Le refroidisseur se compose d'un système de réfrigération à air ou à eau, d'un échangeur de chaleur, d'une pompe de recirculation, d'un réservoir de liquide et d'un contrôleur à microprocesseur.

Les refroidisseurs sont conçus pour fonctionner en continu à l'intérieur, conformément à toutes les procédures et exigences indiquées dans son manuel.

### Installation des refroidisseurs à recirculation

Placez le refroidisseur de manière à ce qu'il soit à proximité et d'accès facile à son dispositif de sectionnement.

Le refroidisseur doit être branché sur une prise dédiée.

Vérifiez que tous les bouchons d'expédition de la tuyauterie sont retirés avant l'installation.

Les raccords du liquide de traitement se situent à l'arrière du refroidisseur et portent les étiquettes  (PROCESS OUTLET, SORTIE LIQUIDE) et  (PROCESS INLET, ENTRÉE LIQUIDE).

Reliez  sur l'entrée du liquide de votre application. Reliez  sur la sortie du liquide de votre application.

Pour les refroidisseurs à eau, reliez  (FACILITY INLET, ENTRÉE INSTALLATION) sur l'alimentation en eau de votre établissement. Reliez  (FACILITY OUTLET, SORTIE INSTALLATION) sur l'évacuation ou le retour d'eau de votre établissement.

Avant de démarrer le refroidisseur, vérifiez deux fois tous les raccords électriques, de plomberie et de communication.



# ES

## Instrucciones básicas de seguridad Refrigeradores de recirculación

Si no se entiende alguna de estas instrucciones, consulte el manual o póngase en contacto con nosotros antes de proceder.

### Seguridad, todos los productos:

 indica una situación de peligro inmediato que, si no se evita, provocará la muerte o lesiones graves.

 indica una situación potencialmente peligrosa que, si no se evita, podría tener como resultado lesiones graves o la muerte.

 indica una situación potencialmente peligrosa que, si no se evita, puede ocasionar lesiones leves o moderadas. También se utiliza para alertar de prácticas inseguras.

 está indicado para alertar al usuario de la presencia de "tensión peligrosa" sin aislar dentro del alojamiento del refrigerador. La magnitud de la tensión es lo suficientemente importante para constituir un riesgo de electrocución.

 indica la presencia de superficies calientes.

 indica que se debe leer el manual.

No utilice el equipo como dispositivo conectado al paciente o dispositivo estéril. Además, el equipo no está diseñado para ser utilizado en lugares peligrosos de Clase I, II o III de acuerdo con el Código Eléctrico Nacional.

Este equipo está diseñado para ser utilizado en interiores solamente. No lo coloque nunca en un lugar donde haya calor excesivo, humedad, ventilación inadecuada o materiales corrosivos. Consulte el manual para conocer los parámetros de funcionamiento.  
Conecte el equipo a una toma correctamente conectada a tierra.

Los refrigerante utilizados son más pesados que el aire y, si hay una fuga, sustituirán al oxígeno, lo que provocará la pérdida de consciencia. El contacto con el refrigerante expulsado provocará quemaduras en la piel. Consulte la placa de datos del circulator para conocer el tipo de refrigerante utilizado y, a continuación, la hoja de datos de seguridad (SDS) más reciente del fabricante para EE.UU., anteriormente conocida como MSDS, así como la hoja de datos de seguridad para la UE a fin de obtener información adicional.

Mueva el equipo con cuidado. Las caídas o los impactos repentinos pueden dañar los componentes. Apague siempre el equipo y desconéctelo de la tensión de suministro antes de moverlo.

Nunca utilice un equipo dañado o con fugas.

Nunca utilice fluidos inflamables o corrosivos. Utilice solo los fluidos aprobados que se incluyen en el manual. Antes de utilizar un fluido o realizar tareas de mantenimiento donde es probable que se entre en contacto con el fluido en cuestión, consulte la hoja de datos de seguridad (SDS) más reciente del fabricante para EE.UU., así como la hoja de datos de seguridad para la UE a fin de obtener información adicional.

Apague siempre el equipo y desconéctelo de la tensión de suministro antes de moverlo.

Delegue las tareas de servicio y las reparaciones en un técnico cualificado.

Guarde el equipo a una temperatura comprendida entre -25 °C y 60 °C (con embalaje), y una humedad relativa de <80%.

El desmantelamiento solo debe ser realizado por un proveedor cualificado que utilice el equipo homologado. Debe cumplirse toda la normativa vigente.

La realización de los procedimientos de instalación, funcionamiento o mantenimiento distintos de los que se describen en el manual puede dar lugar a situaciones peligrosas y anularán la garantía del fabricante.

Nunca aplique tensión de línea a ninguna de las conexiones de comunicación del refrigerador.

Si no se llenan por completo las líneas de fluidos del refrigerador y procesos, podría dañarse la bomba del refrigerador. Evite llenar en exceso; los fluidos se expanden al calentarse.

En el caso de ThermoFlex, antes de sustituir el alojamiento del depósito, asegúrese de que el tope de bola del tubo de control del depósito está en su lugar de forma segura.

En el caso de ThermoFlex900-5000, no utilice el refrigerador a menos que se haya instalado el difusor de fluido del depósito.

Si su refrigerador dispone de una bomba de desplazamiento positivo (P1 o P2), asegúrese de que las líneas de bombeo de la aplicación y los accesorios son capaces de soportar al menos 185 psi.

No utilice anticongelante de automoción. Los anticongelantes comerciales contienen silicatos que dañan las juntas de las bombas.

Para evitar la congelación/el vitriado del intercambiador de la placa, los refrigeradores

ThermoFlex7500-24000 precisan el uso de EG/lagua al 50/50 o PG/lagua al 50/50 con una temperatura de proceso inferior a 10 °C.

Al utilizar una mezcla de fluido para procesos de EG/lagua o PG/lagua, revise la concentración y el pH del fluido periódicamente. Los cambios en la concentración y el pH pueden alterar el rendimiento del sistema.

No utilice un cartucho de filtro de desionización (DI) con EG o PG inhibido. Un filtro DI eliminará los inhibidores de la solución y hará que el fluido sea ineficaz contra la protección anticorrosión. Además, los inhibidores aumentan la conductividad de los fluidos.



Son dañinos si se inhalan, se tragan o se absorben a través de la piel. Consulte la hoja SDS más reciente del fabricante.

Para evitar daños en el intercambiador de la placa del refrigerador, las bombas centrífugas exigen una tasa de caudal mínimo de 4.0 gpm (15.1 lpm).

Si no se limpia/sustituye el filtro del condensador, se producirá una pérdida de capacidad de enfriamiento y esto supondrá un fallo prematuro del sistema de enfriamiento. Para llevar a cabo una limpieza minuciosa, retire el conjunto de la rejilla delantera.

En los refrigeradores enfriados por aire, el bastidor del condensador y las aletas situadas detrás del conjunto de la rejilla delantera son muy afilados.

Nunca utilice el refrigerador con los paneles retirados, salvo el conjunto de la rejilla enfriada por aire.

Los refrigeradores ThermoFlex900-5000 enfriados por agua tienen un ventilador con aspas afiladas. Asegúrese de que el refrigerador está apagado antes de retirar la rejilla delantera.

### Uso previsto, Refrigeradores de recirculación:

Los refrigeradores de recirculación de Thermo Scientific están diseñados para ofrecer un suministro continuo de fluido a una temperatura y una tasa de caudal constantes. Los refrigeradores constan de un sistema de refrigeración enfriado por aire o por agua, un intercambiador de calor, una bomba de recirculación, un depósito de fluido para procesos y un controlador de microprocesador.

Los refrigeradores están diseñados para llevar a cabo un funcionamiento continuo y para utilizarse en interiores de acuerdo con todos los procedimientos y requisitos que se detallan en su manual.



### Instalación, Refrigeradores de recirculación:

Ubique el refrigerador cerca de su dispositivo de desconexión y de forma que resulte fácil acceder a él.

El refrigerador está diseñado para ser utilizado en una toma especial.

Asegúrese de retirar todos los tapones de envío de la línea de tuberías antes de la instalación.

Las conexiones de fluido para procesos se encuentran en la parte posterior del refrigerador y están marcadas con el texto  (PROCESS OUTLET, SALIDA PARA PROCESOS) y  (PROCESS INLET, ENTRADA PARA PROCESOS). Conecte  a la entrada de fluido de su aplicación. Conecte  a la salida de fluido de su aplicación.

En el caso de los refrigeradores enfriados por agua, conecte  (FACILITY INLET, ENTRADA DE LA INSTALACIÓN) al suministro de agua de la instalación. Conecte  (FACILITY OUTLET, SALIDA DE LA INSTALACIÓN) al retorno o al drenaje de agua de la instalación.

Antes de poner en marcha el refrigerador, vuelva a comprobar todas las conexiones de comunicación, eléctricas y de tuberías aplicables.

## Instruções de Segurança Essenciais Refrigeradores de Recirculação

No caso de não compreender qualquer uma destas instruções, consulte o manual ou contacte-nos antes de prosseguir.

### Segurança, todos os produtos:

 Indica uma situação de perigo iminente que, se não for evitada, vai resultar em morte ou lesões graves.

 Indica uma situação de potencial perigo, que se não for evitada, pode resultar em morte ou lesões graves.

 Indica uma situação de potencial perigo, que se não for evitada, pode resultar em ferimentos leves ou moderados. Também é utilizado para alertar contra práticas não seguras.

 Destina-se a alertar o utilizador para a presença de "voltagem perigosa" sem isolamento na caixa do refrigerador. A magnitude da voltagem é suficientemente significante para constituir um risco de choque eléctrico.

 Indica a presença de superfícies quentes.

 Indica a leitura do manual.

Não utilize o equipamento como um dispositivo estéril ou ligado ao paciente. Em complemento, o equipamento não se destina a ser utilizado em Locais Perigosos de Classe I, II ou III conforme definido pelo Código Eléctrico Nacional.

O equipamento destina-se apenas a utilização interior. Nunca o coloque num local onde exista calor em excesso, humidade, ventilação não adequada, ou materiais corrosivos. Consulte o manual relativamente a parâmetros operacionais.

Ligue o equipamento a uma tomada de alimentação com ligação à terra.

Os refrigerantes utilizados são mais pesados do que o ar e, em caso de fuga, vão substituir o oxigénio causando perda de consciência. O contacto com o refrigerante em vazamento vai causar queimaduras na pele. Consulte a placa de identificação do circulador relativamente ao tipo de refrigerante utilizado e depois a Ficha de Segurança (SDS) dos EUA mais recente, anteriormente designada como MSDS, e a Ficha de Segurança da UE para informação adicional.

Movimente o equipamento com cuidado. Solavancos ou quedas súbitas podem danificar os seus componentes. Desactive sempre o equipamento e desligue-o da sua tensão de alimentação antes de o deslocar.

Nunca coloque em funcionamento equipamento danificado ou em vazamento.

Nunca utilize fluidos inflamáveis ou corrosivos. Utilize apenas os fluidos aprovados listados no manual. Antes de utilizar qualquer fluido ou efectuar manutenção onde for provável o contacto com o fluido, consulte a Ficha de Segurança (SDS) dos EUA mais actualizada e a Ficha de Segurança da UE para informação adicional.

Desactive sempre o equipamento e desligue-o da sua fonte de alimentação antes de o deslocar.

As revisões e reparações devem ser efectuadas por um técnico qualificado.

Armazene o equipamento a um intervalo de temperatura entre -25°C a 60°C (com embalagem), e <80% de humidade relativa.

O desmantelamento deve ser apenas efectuado por um representante qualificado utilizando equipamento certificado. Todos os regulamentos predominantes têm de ser seguidos.

Realizar procedimentos de instalação, operação ou manutenção para além dos descritos no manual pode resultar numa situação perigosa e pode invalidar a garantia do fabricante.

Nunca aplique tensão de linha a qualquer uma das ligações de comunicação no refrigerador.

O não enchimento completo do refrigerador e as linhas de fluido de processamento podem danificar a bomba do refrigerador. Evite o enchimento excessivo, já que os fluidos expandem quando aquecidos.

No ThermoFlex, antes de substituir a caixa do reservatório certifique-se de que a tampa de visualização do reservatório está devidamente colocada.

No ThermoFlex900-5000, não opere o refrigerador a menos que o difusor de fluido do reservatório esteja instalado.

Se o seu refrigerador estiver equipado com uma bomba de deslocamento positivo (P1 ou P2), certifique-se de que os seus encaixes e linhas de canalização estão qualificados para suportarem um mínimo de 185 psi.

Não utilize anticongelante automóvel. O anticongelante comercial contém silicatos que danificam os vedantes da bomba.

Para evitar o congelamento/vitrificação do permutador de placa, os refrigeradores

ThermoFlex7500-24000 requerem a utilização de EG/água 50/50 ou PG/água 50/50 abaixo da temperatura de processamento 10°C.

Quando utilizar uma mistura de fluido de processamento de EG/água ou PG/água, verifique a concentração do fluido e o pH regularmente. Alterações na concentração e no pH podem ter impacto no desempenho do sistema.

Não utilize um cartucho de filtro de Desionização (DI) com EG Inibido ou PG Inibido. Um filtro de DI vai remover os inibidores da solução que estão a tornar o fluido ineficaz contra a protecção de corrosão. Para além disso, os inibidores aumentam a condutividade do fluido.

Os bioídias são corrosivos e podem causar lesões oculares irreversíveis e queimaduras na pele. São prejudiciais se inalados, engolidos ou absorvidos através da pele. Consulte a Ficha de Segurança do fabricante mais actualizada.

Para evitar danos no permutador de placa do refrigerador, as bombas centrífugas requerem um caudal mínimo de 4.0 gpm (15.1 lpm).

A não limpeza/substituição do filtro do condensador causa a perda da capacidade de arrefecimento e conduz a uma falha prematura do sistema de arrefecimento. Para uma limpeza mais completa, remova o conjunto da grelha frontal.

Nos refrigeradores refrigerados a ar, a moldura e rebordos do condensador localizados por detrás do conjunto da grelha frontal são muito aguçados.

Para além do conjunto de grelha refrigerada a ar, nunca opere o refrigerador com qualquer painel removido.

Os refrigeradores de refrigeração a água ThermoFlex900-5000 possuem um ventilador com lâminas aguçadas, pelo que se deve assegurar que o refrigerador está desligado antes de remover a grelha frontal.

### **Utilização Prevista, Refrigeradores de Recirculação:**

Os refrigeradores de recirculação Thermo Scientific são concebidos para facultar um fornecimento contínuo de fluido a um fluxo e temperatura constantes. O refrigerador conste num sistema de refrigeração com arrefecimento a ar ou água, permutador de calor, bomba de recirculação, reservatório de fluido de processamento e um controlador de microprocessador.

Os refrigeradores destinam-se a funcionamento contínuo e para utilização interna de acordo com todos os procedimentos e requisitos descritos deste manual.

### **Instalação, Refrigeradores de Recirculação:**

Coloque o refrigerador de forma a que esteja próximo e tenha fácil acesso ao dispositivo de desconexão.

O refrigerador destina-se a utilização numa tomada dedicada.

Certifique-se de que todas as fichas de expedição da linha de canalização são removidas antes da instalação.

As ligações de fluido de processamento encontram-se localizadas na parte posterior do refrigerador e encontram-se etiquetadas  ((PROCESS OUTLET) (SAÍDA DE PROCESSAMENTO)) e  ((PROCESS INLET) (ENTRADA DE PROCESSAMENTO)). Ligue a  à entrada de fluido na sua aplicação. Ligue a  à saída de fluido na sua aplicação.

Para refrigeradores com refrigeração a água ligue a  ((FACILITY INLET) (ENTRADA DE UNIDADE)) ao abastecimento de água da unidade. Ligue a  ((FACILITY OUTLET) (SAÍDA DE UNIDADE)) ao retorno ou drenagem de água da unidade.

Antes de iniciar o refrigerador, verifique todas as ligações de comunicação, eléctricas e tubagens aplicáveis.

## Essentiële veiligheidsinstructies Recirculatiekoelers

Als één van de instructies niet duidelijk is, raadpleeg dan de handleiding of neem contact op met ons vooraleer door te gaan.

### Veiligheid, alle producten:

**DANGER** duidt op een onmiddellijke gevaarlijke situatie die, indien ze niet wordt vermeden, zal leiden tot de dood of ernstige letsels.

**WARNING** duidt op een gevaarlijke situatie die, indien ze niet wordt vermeden, kan leiden tot de dood of ernstige letsels.

**CAUTION** duidt op een mogelijke gevaarlijke situatie die, indien ze niet wordt vermeden, zal leiden tot lichte of middelmatige letsels. Het kan ook gebruikt worden als waarschuwing tegen onveilige praktijken.

 bedoeld om de gebruiker te waarschuwen voor de aanwezigheid van een niet-geïsoleerde "gevaarlijke spanning" binnenin de behuizing van de koeler. De grootte van de spanning is voldoende significant om een gevaar te vormen op een elektrisch schok.

 duidt op de aanwezigheid van hete oppervlakken.

 duidt op het raadplegen van de handleiding.

Gebruik de apparatuur niet als steriel of als een met de patiënt verbonden apparaat. Daarnaast is de apparatuur niet ontworpen voor gebruik in gevaarlijke locaties van klasse I, II of III zoals gedefinieerd door de National Electrical Code.

De apparatuur is uitsluitend bedoeld voor gebruik binnenshuis. Plaats deze nooit op een locatie met overmatige hitte, vochtigheid, onvoldoende ventilatie of waar er corrosieve materialen aanwezig zijn. Raadpleeg de handleiding voor de operationele parameters.

Sluit de apparatuur steeds aan op een goed geaard stopcontact.

Koelmiddelen zijn zwaarder dan lucht en als er een lek is, zal het de zuurstof vervangen en kan dit leiden tot bewusteloosheid. Contact met het lekkende koelmiddel kan leiden tot brandwonden op de huid. Raadpleeg het typeplaatje van de circulatiepomp voor het type koelmiddel dat wordt gebruikt en raadpleeg vervolgens het meest recente veiligheidsgegevensblad (Safety Data Sheet - SDS) van de producent, eerder gekend als MSDS, en het Europese veiligheidsgegevensblad voor extra informatie.

Verplaats de apparatuur steeds erg zorgvuldig. Plotsse schokken of druppels kunnen de componenten beschadigen. Schakel de apparatuur steeds uit en haal de stekker uit het stopcontact vooraleer deze te verplaatsen.

Gebruik nooit beschadigde of lekkende apparatuur.

Gebruik nooit ontvlambare of corrosieve vloeistoffen. Maak alleen gebruik van de goedgekeurde vloeistoffen in de handleiding. Raadpleeg, vooraleer een vloeistof te gebruiken of onderhouden uit te voeren waarbij het waarschijnlijk is dat u in aanraking komt met de vloeistof, het meest recente veiligheidsgegevensblad (Safety Data Sheet - SDS) van de producent en het Europese veiligheidsgegevensblad voor extra informatie.

Schakel de apparatuur steeds uit en haal de stekker uit het stopcontact vooraleer deze te verplaatsen. Laat het onderhoud en de herstellingen steeds uitvoeren door een gekwalificeerd technicus.

Sla de apparatuur op bij een temperatuur tussen -25°C tot 60°C (met verpakking) en een relatieve vochtigheid van minder dan 80%.

Het buiten dienst stellen mag alleen uitgevoerd worden door een gekwalificeerde dealer die gebruik maakt van gecertificeerde uitrusting. Alle geldende regelgevingen moeten worden gevolgd.

Het uitvoeren van de installatie-, de werkings- of onderhoudsprocedures op een andere manier dan beschreven in de handleiding kan leiden tot een gevaarlijke situatie en zal de garantie van de producent ongeldig maken.

Sluit nooit de netspanning aan op de communicatie-aansluitingen van de koeler.

Het volledig vullen van de koeler en de leidingen met procesvloeistof kan de koelpomp beschadigen. Vermijd het overvullen omdat vloeistoffen uitzetten wanneer ze worden opgewarmd.

Verzeker bij ThermoFlex voor het vervangen van de behuizing van het reservoir dat de balstopper van de kijkbuis van het reservoir stevig is bevestigd.

Stel de koeler van een ThermoFlex900-5000 niet in werking tenzij het reservoir van de vloeistofdiffuser is geïnstalleerd.

Als uw koeler is uitgerust met een positieve verplaatsingspomp (P1 of P2), verzeker dan dat uw leidingen en fittingen bestand zijn tegen minimaal 185 psi.

Gebruik geen antivriesmiddel voor auto's. Commercieel antivriesmiddel bevat silicaten die de pompdichtingen kunnen beschadigen.

Om het bevroren van en het ontstaan van een ijslaagje op de plaatvormige warmtewisselaar te voorkomen, vereisen de ThermoFlex7500-24000-koelers het gebruik van 50/50 EG/water of 50/50 PG/water bij een temperatuur onder 10°C.

Bij gebruik van een mix van procesvloeistoffen van EG/water of PG/water dient u de vloeistofconcentratie en pH op een regelmatige basis te controleren. Wijzigingen in de concentratie en de pH kunnen een impact hebben op de prestaties van het systeem.

Gebruik geen deionisatie(DI)-filtercartridge met Inhibited EG of Inhibited PG. Een DI-filter zal remmers uit de vloeistof verwijderen waardoor de vloeistof niet meer effectief is als bescherming tegen corrosie. Daarnaast verhogen remmers de geleiding van vloeistoffen.

Biociden zijn corrosief en kunnen onherstelbare schade toebrengen aan de ogen en ook brandwonden veroorzaken. Ze zijn schadelijk als ze worden geïnhaleerd, worden ingeslikt of worden opgenomen via de huid. Raadpleeg het meest recente veiligheidsgegevensblad (SDS) van de producent.

Om schade te voorkomen aan de plaatvormige warmtewisselaar, vereisen de centrifugale pompen een minimale doorstroming van 15,1 liter per minuut.

Het nalaten om de filter van de condensor te reinigen of te vervangen kan leiden tot een verlies van koelcapaciteit en tot het voortijdig defect raken van het koelsysteem. Verwijder de rooster aan de voorzijde voor een grondige reiniging.

Bij luchtgekoelde koelers bevinden het kader en de vinnen van de condensor zich achter de voorste rooster en dient u goed op te letten want ze zijn erg scherp.

Bij andere koelers dan degene met een luchtgekoeld rooster mag u de koeler nooit activeren wanneer het paneel verwijderd is.

ThermoFlex900-5000 watergekoelde koelers beschikken over een ventilator met scherpe schoepen, zorg ook dat de koeler is uitgeschakeld vooraleer de rooster vooraan wordt verwijderd.

### **Bedoeld gebruik, recirculatiekoelers:**

De recirculatiekoelers van Thermo Scientific zijn ontworpen om een continue toevoer van vloeistoffen te voorzien met een constante temperatuur en doorstroming. De koeler bestaat uit een luchtgekoeld of watergekoeld koelsysteem, warmtewisselaar, recirculatiepomp, reservoir voor procesvloeistof en een microprocessorcontroller.





Koelers zijn ontworpen voor een continue werking en voor gebruik binnenshuis in overeenkomst met alle procedures en vereisten die staan vermeld in de handleiding.

### **Installatie, recirculatiekoelers:**

Plaats de koeler zodat deze zich dichtbij het loskoppelapparaat bevindt en dat deze eenvoudig toegankelijk is.

De koeler is bedoeld voor gebruik op een daartoe bestemde uitvoer.

Verzeker dat alle transportpluggen op de leidingen zijn verwijderd voor de installatie.

De aansluitingen van de procesvloeistof bevinden zich op de achterzijde van de koeler en hebben een label  (PROCESS OUTLET (PROCESUITVOER)) en  (PROCESS INLET (PROCESTOEVOER)). Sluit de  aan op de vloeistoftoevoer van uw applicatie. Sluit de  aan op de vloeistofuitvoer van uw applicatie.

Sluit voor watergekoelde koelers de  (FACILITY INLET (TOEVOER VAN DE FACILITEIT)) aan op watertoevoer van uw faciliteit. Sluit de  (FACILITY OUTLET (UITVOER VAN DE FACILITEIT)) aan op de waterretour of -afvoer van de faciliteit.

Vooraleer de koeler te starten dient u alle van toepassing zijnde communicatie-aansluitingen, elektrische aansluitingen en leidingaansluitingen tweemaal te controleren.



## Istruzioni essenziali per la sicurezza Chiller a ricircolazione

Se queste istruzioni non sono chiare, fare riferimento al manuale oppure contattare il nostro ufficio prima di procedere.

### Sicurezza, tutti i prodotti:

**⚠ DANGER** indica una situazione di pericolo imminente che, se non evitata, potrebbe causare morte o ferite gravi.

**⚠ WARNING** indica una situazione potenzialmente pericolosa che se non evitata potrebbe causare lesioni gravi o morte.

**⚠ CAUTION** indica una situazione di pericolo potenziale che, se non evitata, potrebbe causare ferite lievi o non gravi. Viene anche utilizzato come avviso contro pratiche non sicure.

 destinato ad avvisare l'utente della presenza di "tensioni pericolose" non isolate all'interno dell'involucro del chiller. Il valore della tensione è abbastanza significativo da costituire un rischio di scosse elettriche.

 indica la presenza di superfici calde.

 segnala di leggere il manuale.

Non utilizzare l'apparecchiatura come dispositivo sterile o collegato a un paziente. Inoltre, l'apparecchiatura non è progettata per l'utilizzo in luoghi pericolosi di Classe I, II o III secondo le definizioni del National Electrical Code.

Questa apparecchiatura è destinata all'uso in ambienti chiusi. Non collocarla mai in luoghi soggetti a calore eccessivo, umidità, ventilazione inadeguata o materiali corrosivi. Fare riferimento al manuale per i parametri operativi.

Collegare l'apparecchiatura ad una presa di rete adeguatamente messa a terra.

I refrigeranti utilizzati sono più pesanti dell'aria e, in caso di perdite, possono sostituire l'ossigeno causando perdita di conoscenza. Il contatto della pelle con il refrigerante fuoriuscito causa ustioni. Per ulteriori informazioni, fare riferimento alla targhetta del circuito circolatore per il tipo di refrigerante utilizzato e ai dati tecnici di sicurezza aggiornati del produttore (US Safety Data Sheet - SDS), precedentemente noti come MSDS, non che ai dati tecnici di sicurezza UE.

Spostare l'apparecchiatura con cautela. Sobbalzi o cadute improvvisi possono danneggiare i suoi componenti. Spegnerne sempre l'apparecchiatura e scollegarla dalla tensione di alimentazione prima di spostarla.

Non utilizzare mai apparecchiature danneggiate o con perdite.

Non utilizzare mai fluidi infiammabili o corrosivi. Utilizzare esclusivamente i fluidi certificati elencati nel manuale. Prima di utilizzare fluidi o eseguire operazioni di manutenzione che prevedano il contatto con il fluido, fare riferimento ai dati tecnici di sicurezza aggiornati del produttore (US Safety Data Sheet - SDS) e ai dati tecnici di sicurezza UE per ulteriori informazioni.

Spegnerne sempre l'apparecchiatura e scollegarla dalla tensione di alimentazione prima di spostarla.

Demandare assistenza e riparazioni ad un tecnico qualificato.

Conservare l'apparecchiatura ad una temperatura compresa tra -25°C e 60°C (con imballo), e una umidità relativa <80%.

La disattivazione deve essere eseguita solo da rivenditori qualificati utilizzando attrezzature certificate. Dovranno essere rispettate tutte le norme vigenti.

L'esecuzione di procedure di installazione, funzionamento o manutenzione diverse da quelle descritte nel manuale potrebbero determinare situazioni di pericolo e causare l'annullamento della garanzia del produttore.

Non applicare mai la tensione di linea alle connessioni di comunicazione presenti sul chiller.

Il riempimento incompleto delle linee di trasmissione di fluido per il processo e il chiller può danneggiare la pompa dell'apparecchio. Evitare comunque di riempire in eccesso, in quanto i fluidi si espandono se riscaldati.

Su ThermoFlex, prima di sostituire l'involucro del serbatoio, assicurarsi che il fermo sferico del tubo di verifica serbatoio sia posizionato in sicurezza.

Su ThermoFlex900-5000, non azionare il chiller se non è installato il diffusore di fluido del serbatoio.

Se il chiller è provvisto di una pompa volumetrica positiva (P1 o P2), assicurarsi che le tubazioni dell'applicazione e i relativi raccordi possano resistere ad una pressione di almeno 185 psi.

Non utilizzare antigelo per autotrazione. L'antigelo commerciale contiene silicati che danneggiano le guarnizioni della pompa.

Per evitare il congelamento dello scambiatore a piastra, i chiller ThermoFlex7500-24000 richiedono l'utilizzo di 50/50 EG/acqua o 50/50 PG/acqua sotto la temperatura di processo di 10°C.

Quando si utilizza una miscela di fluido di EG/acqua o PG/acqua, verificare periodicamente la concentrazione del fluido e il pH. Eventuali variazioni di concentrazione e pH possono compromettere le prestazioni del sistema.



Non utilizzare un cartuccia filtro di deionizzazione (DI) con EG o PG inibiti. Un filtro DI rimuoverà gli inibitori dalla soluzione, rendendo il fluido inefficace contro la corrosione. Inoltre, gli inibitori fanno aumentare la conduttività del fluido.

I biocidi sono corrosivi e possono causare danni irreversibili agli occhi e ustioni cutanee. Sono pericolosi se inalati, ingeriti o assorbiti attraverso la pelle. Fare riferimento ai documenti SDS più aggiornati del produttore.

Per evitare danni allo scambiatore a piastra del chiller, le pompe centrifughe richiedono una portata minima di 4,0 gpm (15,1 lpm).

La mancata pulizia/sostituzione del filtro del condensatore provoca una perdita della capacità di raffreddamento con il rischio di guasti prematuri del sistema di raffreddamento. Per una pulizia approfondita, togliere il gruppo della griglia anteriore.

Nei chiller raffreddati ad aria le alette ed il telaio del condensatore dietro il gruppo della griglia anteriore sono molto affiati.

Non azionare mai il chiller con pannelli rimossi, ad eccezione del gruppo griglia raffreddato ad aria. I chiller raffreddati ad acqua ThermoFlex900-5000 dispongono di una ventola con pale affilate; assicurarsi che il chiller sia spento prima di rimuovere la griglia anteriore.

### **Destinazione d'uso, chiller a ricircolazione:**

I chiller a ricircolazione Thermo Scientific sono progettati per fornire un'alimentazione continua di fluido a temperatura e portata costanti. Il chiller è composto da un sistema di refrigerazione raffreddato ad aria o ad acqua, uno scambiatore di calore, una pompa di ricircolazione, un serbatoio del fluido di processo e un controller a microprocessore.

I chiller sono progettati per il funzionamento continuo e per l'utilizzo in ambienti chiusi, in conformità con tutte le procedure e i requisiti definiti in questo manuale.

### **Installazione, chiller a ricircolazione:**

Posizionare il chiller in modo che sia vicino ed abbia un pratico accesso al suo dispositivo di disconnessione.

Il chiller deve essere utilizzato su una presa dedicata.

Assicurarsi che tutte le spine utilizzate per la spedizione nelle linee di tubazione siano state rimosse prima di procedere all'installazione.

Le connessioni per il fluido di processo si trovano sul retro del chiller e sono etichettati  (PROCESS OUTLET) e  (PROCESS INLET). Collegare  all'ingresso del fluido sull'applicazione. Collegare  all'uscita del fluido sull'applicazione.

Per i chiller raffreddati ad acqua collegare  (FACILITY INLET) all'alimentazione idraulica dell'impianto. Collegare  (FACILITY OUTLET) al ritorno o scarico dell'acqua dell'impianto.

Prima di avviare il chiller, ricontrollare tutte le linee di comunicazione e le connessioni elettriche e delle tubazioni.



## Важни инструкции за безопасност Рециркуляционни охладители

Ако някоя от тези инструкции не бъде разбрана, се обрънете към ръководството или се свържете с нас, преди да продължите.

### Безопасност, всички продукти:



указва непосредствено опасна ситуация, която, ако не бъде избегната, ще доведе до смърт или тежка телесна повреда.



указва потенциално опасна ситуация, която, ако не бъде избегната, може да доведе до смърт или тежка телесна повреда.



указва потенциално опасна ситуация, която, ако не бъде избегната, може да доведе до лека или средна телесна повреда. Също така се използва, за да предупреждава срещу опасни практики.



предназначен да предупреждава потребителя за наличие на неизолирано "опасно напрежение" в рамките на корпуса на охладителя. Величината на напрежението е достатъчно значима, за да поражда риск от електрически удар.



указва наличието на горещи повърхности.



указва, че ръководството трябва да се прочете.

Не използвайте оборудването като стерилно устройство или устройство, свързано с пациенти. В допълнение устройството не е предназначено за употреба в клас I, II или III опасни места, както е определено от Националния закон за електричеството на САЩ (NEC).

Оборудването е предназначено само за употреба в закрити помещения. Никога не го поставяйте на място, където са налице прекомерна топлина, влага, лоша вентилация или корозивни материали. Вижете ръководството за експлоатационните параметри.

Свържете оборудването към правилно заземен контакт.

Използваните хладилни агенти са по-тежки от въздуха и, ако има теч, те ще заменят кислорода, причинявайки загуба на съзнание. Контактът с изтичащ хладилен агент ще предизвика изгаряния на кожата. Направете справка с фирмената табела на циркулатора за типа на използвания хладилен агент, след което към най-актуалния информационен лист за безопасност на САЩ (SDS) от производителя, известен преди като MSDS, и също така и към информационния лист за безопасност на ЕС, за допълнителна информация.

Премествайте оборудването внимателно. Внезапни сътресения или изпускания могат да повредят компонентите му. Винаги изключвайте устройството и го разкачвайте от неговото ذخраняващо напрежение, преди да го преместите.

Никога не експлоатирайте повредено оборудване или оборудване с течове.

Никога не използвайте запалими или корозивни течности. Използвайте само одобрените течности, посочени в ръководството. Преди да се използва каквато и да било течност или да се прави поддръжка, където е вероятно да има контакт с течността, направете справка с най-актуалния информационен лист за безопасност на САЩ (SDS) от производителя, както и информационния лист за безопасност на ЕС, за допълнителна информация.

Винаги изключвайте устройството и го разкачвайте от неговото ذخраняващо напрежение преди преместване.

За обслужване и ремонтни дейности се обрънете към квалифициран техник.

Съхранявайте оборудването при температура от  $-25^{\circ}\text{C}$  до  $60^{\circ}\text{C}$  (с опаковката) и  $<80\%$  относителна влажност.

Извеждането от експлоатация трябва да се извършва само от квалифициран дилър, като се използва сертифицирано оборудване. Всички действащи разпоредби трябва да се спазват.

Извършване на монтаж, експлоатация или процедури за поддръжка, различни от тези, описани в ръководството, може да доведе до опасна ситуация и ще анулира гаранцията на производителя.

Никога да не се прилага линейно напрежение към някоя от комуникационните връзки на охладителя.

Непълното запълване на охладителя и на технологичните тръбопроводи за течности може да повреди помпата на охладителя. Избягвайте препълването, защото течностите се разширяват при нагряване.

За ThermoFlex, преди да подмените корпуса на резервоара, се уверете, че топката-запушалка на контролната тръба на резервоара е надлежно поставена на място.

За ThermoFlex900-5000 не експлоатирайте охладителя, освен ако не е инсталиран дифузерът за течности на резервоара.

Ако охладителят е оборудван с обемна нагнетателна помпа (P1 или P2), се уверете, че водопроводните тръби и фитинги на приложението са проектирани да издържат минимум 185 psi. Не използвайте антифриз от автомобилната индустрия. Серийният антифриз съдържа силикати, които увреждат уплътненията на помпата.

За да се предотврати замръзването/гланциране на пластинния топлообменник, охладителите ThermoFlex7500-24000 изискват употребата на 50/50 EG/вода или 50/50 PG/вода с температура за обработка под  $10^{\circ}\text{C}$ .

Когато се използва смес от технологична течност от EG/вода или PG/вода, редовно проверявайте концентрацията на течността и pH. Промениите в концентрацията и pH могат да окажат влияние върху производителността на системата.

Не използвайте дейонизиращ (DI) патронен филтър с инхибирана EG или инхибирана PG. DI филтърът ще премахне инхибиторите от разтвор, правейки течността неефективна при защита от корозия. Също така инхибиторите повишават проводимостта на течността.

Бицидите са корозивни и могат да предизвикат необратими увреждания на очите и изгаряния на кожата. Те са вредни при вдишване, поглъщане или абсорбиране през кожата. Направете справка с най-актуалния SDS на производителя.

За да се предотврати повреда на пластинния топлообменник на охладителя, центробежните помпи изискват 4,0 gpm (15,1 lpm) минимален дебит.

Непочистването/неподмяната на кондензаторния филтър ще причини загуба на капацитета на охладяване и ще доведе до преждевременна повреда на охладящата система. За цялостно почистване извадете модула на предната решетка.

При охладителите с въздушно охлаждане рамките и перките на кондензатора, разположени зад модула на предната решетка, са много остри.

Освен модула на решетката за въздушно охлаждане, никога не експлоатирайте охладителя с който и да било друг отстранен панел.

Охладителите ThegmoFlex900-5000 с водно охлаждане имат вентилатор с остри перки и затова се уверете, че охладителят е изключен, преди да премахнете предната решетка.

### **Предназначена употреба, рециркуляционни охладители:**

Рециркуляционните охладители на Thegmo Scientific са предназначени да осигуряват непрекъснато подаване на течност при постоянна температура и дебит. Охладителят се състои от хладилна система с въздушно охлаждане или водно охлаждане, топлообменник, рециркуляционна помпа, резервоар за технологична течност и микропроцесорен контролер.

Охладителите са предназначени за непрекъсваема експлоатация и за употреба на закрито в съответствие с всички процедури и изисквания, посочени в съответното ръководство.

### **Монтиране, рециркуляционни охладители:**

Разположете охладителя, така че да е близо и да има лесен достъп до устройството му за изключване.

Охладителят е предназначен за употреба с отделен контакт.

Уверете се, че всички тапи за транспортиране на водопроводните тръби са отстранени преди монтажа.

Връзките на технологичната течност се намират на гърба на охладителя и са отбелязани с етикети  (ТЕХНОЛОГИЧЕН ИЗХОД) и  (ТЕХНОЛОГИЧЕН ВХОД). Свържете  към входа за течности на вашето приложение. Свържете  към изхода за течности на вашето приложение.

За охладители с водно охлаждане свържете  (ВХОД ЗА ПРОМИШЛЕНА) към източника на промишлена вода. Свържете  (ИЗХОД ЗА ПРОМИШЛЕНА) към връщащата тръба за промишлена вода или канала.

Преди да стартирате охладителя, проверете отново всички приложими комуникационни, електрически и водопроводни връзки.

## Základní bezpečnostní pokyny Recirkulační chladiče

Pokud některým z těchto pokynů nebudete rozumět, nahlédněte před pokračováním do návodu k obsluze nebo nás kontaktujte.

### Bezpečnost, všechny produkty:

**DANGER** Značí bezprostředně nebezpečnou situaci, která pokud nebude odstraněna, povede ke smrtelnému nebo závažnému úrazu.

**WARNING** Značí potenciálně nebezpečnou situaci, která pokud nebude odstraněna, může vést ke smrtelnému nebo závažnému úrazu.

**CAUTION** Značí potenciálně nebezpečnou situaci, která pokud nebude odstraněna, může vést k méně až středně závažnému úrazu. Slouží také jako výstraha před nebezpečnými postupy.

 Slouží k upozornění uživatele na přítomnost neizolovaného „nebezpečného napětí“ v krytu chladičích zařízení. Napětí je dostatečně vysoké na to, aby představovalo riziko úrazu elektrickým proudem.

 Značí přítomnost horkých povrchů.

 Značí, že si má obsluha přečíst návod k obsluze.

Vybavení nepoužívejte jako sterilní zařízení nebo zařízení připojené k pacientovi. Zařízení navíc není určeno k používání v rizikových lokalitách třídy I, II nebo III podle národních elektrotechnických předpisů.

Zařízení je navrženo pouze pro používání ve vnitřních prostorech. Nikdy ho neumisťujte do míst, kde je nadměrné teplo, vlhkost, nedostatečná ventilace nebo kde se nachází korozivní materiály. Provozní parametry jsou uvedené v návodu k obsluze.

Připojte zařízení k řádně uzemněné zásuvce.

Použitá chladiva jsou těžší než vzduch a pokud dojde k jejich úniku, vytlačí veškerý vzduch a způsobí ztrátu vědomí. Kontakt s unikajícím chladivem způsobí popálení pokožky. Typ použitého chladiva zjistíte na štítku s technickými údaji cirkulačního termostatu a další informace jsou uvedeny v aktuálním bezpečnostním listu výrobce.

Při stěhování zařízení buďte opatrní. Náhlé nárazy nebo pády mohou poškodit jeho součásti. Před stěhováním zařízení vždy vypněte a odpojte ho od přívodu napájení.

Nikdy nepoužívejte poškozené nebo netěsné zařízení.

Nikdy nepoužívejte hořlavé nebo korozivní kapaliny. Používejte pouze schválené kapaliny uvedené v návodu k obsluze. Před použitím nějaké kapaliny nebo před prováděním údržby, kde je pravděpodobné, že přijdete s touto kapalinou do styku, si zjistěte další informace v aktuálním bezpečnostním listu výrobce. Před stěhováním zařízení vždy vypněte a odpojte ho od přívodu napájení.

Servis a opravy přenechejte kvalifikovaným servisním technikům.

Skládejte zařízení při teplotách -25°C až 60°C (v obalu), a při relativní vlhkosti vzduchu nižší než 80 %.

Výrazení z provozu smí provádět pouze kvalifikovaný prodejce s pomocí certifikovaného vybavení. Musí být dodržena veškerá platná nařízení.

Provádění jiných postupů při instalaci, obsluze nebo údržbě, než které jsou popsány v návodu k obsluze, může vést k nebezpečným situacím a způsobí zneplatnění záruky výrobce.

Nikdy nepřivádějte elektrické napětí k žádným komunikačním konektorům chladičích zařízení.

Když není chladičích zařízení a potrubí kompletně naplněné chladičí kapalinou, může dojít k poškození čerpadla. Zařízení nepřepínájte, kapalinu při zahřátí nabyvájí na objemu.

V případě zařízení ThermoFlex se před výměnou krytu nádržky přesvědčte, jestli je bezpečně na svém místě kuličková zarážka trubcového průzoru.

Zařízení ThermoFlex900-5000 neuvádějte do provozu, dokud není nainstalovaný difúzér kapaliny v nádržce.

Pokud je chladičích zařízení vybavené objemovým čerpadlem (P1 nebo P2), přesvědčte se, jestli hadice, potrubí a spojky vaší instalace vydrží tlak minimálně 185 psi.

Nepoužívejte automobilový odmrazovač. Běžně prodáváné odmrazovače obsahují silikáty, které poškodí těsnění čerpadla.

Aby nedocházelo k zamrznutí deskového výměníku nebo jeho pokrytí ledem, chladičích zařízení ThermoFlex7500-24000 vyžadují používání směsi etylenglykolu a vody v poměru 1:1 nebo směsi propylenglykolu a vody v poměru 1:1 s procesní teplotou nižší než 10 °C.

Při používání směsi etylenglykolu a vody nebo propylenglykolu a vody pravidelně kontrolujte koncentraci kapaliny a pH. Změny v koncentraci a pH mohou mít vliv na výkon systému. Nepoužívejte kazetu deionizačního filtru s inhibovaným etylenglykolem nebo inhibovaným propylenglykolem.

Deionizační filtr z roztoku odstraní inhibitory, takže kapalina přestane narušovat antikorozní ochranu.

Biocidní přípravky jsou korozivní a mohou způsobit nevratné poškození očí a popáleniny pokožky. Při vdechnutí, spolknutí nebo vstřebání pokožkou jsou škodlivé. Podívejte se do aktuálních bezpečnostních listů výrobce.

Aby nemohlo dojít k poškození deskového výměníku chladičích zařízení, vyžadují odstředivá čerpadla minimální průtok 15,1 l/m).

Nedostatečně vyčištěný nebo nevytěžený filtr kondenzátoru způsobuje ztrátu chladičích kapacity a vede k předčasnému selhání systému.

V zájmu důkladného vyčištění demontujte přední mřížku. U vzduchem chlazených chladičů jsou rám kondenzátoru a jeho žebra za přední mřížkou velmi ostré.

V případě mřížky chlazené jinak než vzduchem nikdy chladicí zařízení nepoužívejte s demontovanými panely.

Vodou chlazené chladiče ThermoFlex900-5000 mají ventilátor s ostrými lopatkami, takže se před demontáží přední mřížky přesvědčte, že je chladič vypnutý.

### **Určené použití, recirkulační chladiče:**

Recirkulační chladiče společnosti Thermo Scientific jsou navrženy pro zajišťování nepřetržitého přívodu kapaliny při konstantní teplotě a konstantním průtoku. Chladič se skládá ze vzduchem chlazeného nebo vodou chlazeného chladičového systému, tepelného výměníku, recirkulačního čerpadla, nádržky na procesní kapalinu a řídicí jednotky s mikroprocesorem.



Chladiče jsou navrženy pro nepřetržitý provoz a používání ve vnitřních prostorech v souladu se všemi postupy a požadavky, uvedenými v jejich návodech k obsluze.

### **Instalace, recirkulační chladiče:**

Umístěte chladič tak, aby byl v blízkosti svého odpojovacího zařízení a aby byl k odpojovacímu zařízení snadný přístup.

Chladičí zařízení č je určen pro používání se samostatným výstupem.

Před instalací musí být odstraněny všechny přepravní zátky na potrubích a hadicích.

Připojky procesní kapaliny jsou umístěné na zadní části chladiče a jsou označené  (PROCESS OUTLET – procesní výstup) a  (PROCESS INLET – procesní přívod). Připojte kapalinu na zařízení. Připojte  k výstupu kapaliny na zařízení.

V případě vodou chlazených chladičů připojte  (FACILITY INLET – přívod ze závodu) k přívodu vody ze závodu. Připojte  (FACILITY OUTLET – výstup kapaliny do závodu) k odtoku vody v závodu.

Před spuštěním chladiče překontrolujte příslušné komunikační a elektrické připojky a připojovací armatury.





## Essentiell sikkerhedsvejledning Recirkulerende nedkølere

Hvis nogle af disse instrukser ikke kan forstås, så referer til manualen, eller kontakt os, før du fortsætter.

### Sikkerhed, alle produkter:

**DANGER** Indikerer en omgående farlig situation, som, hvis den ikke undgås, vil resultere i død eller alvorlig skade.

**WARNING** Indikerer en potentielt farlig situation, som, hvis den ikke undgås, vil resultere i død eller alvorlig skade.

**CAUTION** Indikerer en potentielt farlig situation, som, hvis den ikke undgås, kan resultere i mindre eller moderat skade. Den bruges også til at advare mod usikre fremgangsmåder.

 beregnet til at advare brugeren om tilstedeværelsen af ikke-isoleret "farlig spænding" inden for nedkølerens indelukke. Spændingens styrke er markant nok til at udgøre risiko for elektrisk stød.

 indikerer tilstedeværelsen af varme overflader.

 indikerer læs manualen.

Brug ikke udstyret som en steril eller patientforbundet enhed. Derudover er udstyret ikke designet til brug i Klasse I, II eller III farlige steder som defineret af National Electrical Code.

Udstyret er kun designet til indendørs brug. Placer det aldrig et sted, hvor der findes overdreven varme, fugtighed, ufilstrækkelig ventilation eller ætsende materialer. Referer til manualen for driftsparametre.

Forbind udstyret til en korrekt jordet stikkontakt.

Kølemidler, der bruges her, er tungere end luft, og hvis der er en læk, vil det erstatte oxygenet, hvilket forårsager tab af bevidsthed. Kontakt med lækkende kølemidler vil forårsage hudforbrændinger. Referer til cirkulatorens navneplade for den type kølemiddel, der bruges, og så producentens mest aktuelle amk. sikkerhedsdataark (SDS), tidligere kendt som MSDS, og EUs sikkerhedsdataark for yderligere oplysninger.

Flyt udstyret forsigtigt. Pludselige stød eller tab kan beskadige dets komponenter. Sluk altid udstyret, og afbryd det fra dets strømforsyning, før det flyttes.

Bejten aldrig beskadiget eller lækkende udstyr.

Brug aldrig brændbare eller ætsende væsker. Brug kun tilladte væsker, der er angivet i manualen. Før du bruger nogen væske eller udfører vedligeholdelse, hvor kontakt med væsken er sandsynlig, skal du referere til producentens mest aktuelle amk. sikkerhedsdatablad (SDS) og EUs sikkerhedsdatablad for yderligere oplysninger.

Sluk altid udstyret, og afbryd det fra dets strømforsyning, før det flyttes.

Hvis vedligeholdelse og reparation til en kvalificeret tekniker.

Opbevar udstyret i et temperaturinterval på -25 °C til 60 °C (med indpakning), og <80 % relativ luftfugtighed.

Dekommisionering skal kun udføres af en kvalificeret forhandler, der bruger certificeret udstyr. Alle aktuelle regulativer skal følges.

Udførelse af installation, drift eller vedligeholdelsesprocedurer andre end dem, der er beskrevet i denne manual, kan resultere i en farlig situation og vil annullere producentens garanti.

Påfør aldrig linjespænding til nogen kommunikationsforbindelse på nedkøleren.

Hvis du ikke fylder nedkøler- og procesvæskelinjer helt, kan det beskædige nedkølerens pumpe. Undgå at overfylde. Væsker ekspanderer, når de varmes op.

På ThermoFlex, før du erstatter reservoir-kabinettet, skal du sikre, at den synlige reservoir-rørkuglestopper er sikkert på plads.

På ThermoFlex900-5000 må du ikke bejlene nedkøleren, før reservoir-væskediffuseren er installeret.

Hvis din nedkøler er udstyret med en positiv forskydningspumpe (P1 or P2), skal du sikre, at din applikation af rørlinjer og beslag er vurderet til at modstå et minimum af 185 psi

Ber nyt ikke automobil kølevæske. Kommerciel kølevæske indeholder silikater, der skader pumpeforseglingen.

For at forebygge frysningsglasering af pladeudveksleren kræver ThermoFlex7500-24000 nedkølere brug af 50/50 EG/vand eller 50/50 PG/vand under 10 °C processtemperatur.

Når du bruger en procesvæskemikstur af EG/vand eller PG/vand, skal du kontrollere væskekoncentrationen og pH jævnligt. Ændringer i koncentrationen og pH kan have indflydelse på systemydelsen.

Brug ikke en deioniserings (DI) filterpatron med inhiberet EG eller inhiberet PG. Et DI-filter vil fjerne inhibitorer fra opløsningen, hvilket gør væsken ineffektiv mod beskyttelse mod korrosion. Inhibitorer forøger også væskens ledeevne.

Biocider er ætsende og kan forårsage irreversibel øjenskade og hudforbrændinger. De er skadelige, hvis de inhaleres, sluges eller absorberes gennem huden. Referer til producentens mest aktuelle SDS.

For at forebygge skade på nedkølerens pladeudveksler kræver centrifugalpumper en minimumstrømråde på 4,0 gpm (15,1 lpm).

Hvis kondensatoren ikke rengøres/udskiftes, kan det forårsage et tab af kølekapacitet og føre til tidlig fejlfunktion af kølesystemet. For en grundig rengøring skal du fjerne fronttrissamlingen.

På luftkølede nedkølere er kondensatorramme og -finer bag fronttrissamlingen meget skarpe.

Ud over den luftkølede ristsamling må du aldrig bejlene nedkøleren med nogen aftagne paneler.

ThermoFlex900-5000 vandkølede nedkølere har en blæser med skarpe klinger, så sørg for, at nedkøleren er slukket, før fronttristen fjernes.

### Tilsluttet brug, recirkulerende nedkølere:

Thermo Scientific recirkulerende nedkølere er designet til at yde en løbende væskeforsyning ved en konstant temperatur og strømningsrate. Nedkøleren består af et luftkølet eller vandkølet kølesystem, varmeveksler, recirkuleringspumpe, procesvæskerereservoir og en mikroprocessor-controller.





Nedkølere er designet til løbende drift og til indendørs brug i henhold til alle procedurerne og kravene formuleret i denne håndbog.

### Installation, recirkulerende nedkølere:

Placer nedkøleren, så den er nær, og har nem adgang til, dens afbryderenhed.

Nedkøleren er beregnet til brug i en dedikeret strømtilslutning.

Sørg for, at alle vvs-linjers shipping-stik fjernes før installation.

Procesvæskeforbindelserne befinder sig bag på nedkøleren og er markeret  (PROCESS INLET) og  (PROCESS OUTLET) og  til væskeindtaget på din applikation. Forbind  til væskeudløbet på din applikation. Forbind  til væskeudløbet på din applikation.

For vandkølede nedkølere skal du forbinde  (FACILITY INLET) til din facilitets vandforsyning. Forbind  (FACILITY OUTLET) til din facilitets vandreturering eller afløb.

Før du starter nedkøleren, skal du kontrollere alle relevante kommunikations-, elektriske og vvs-forbindelser en ekstra gang.



## Βασικές οδηγίες ασφαλείας Ψύκτες επανακυκλοφορίας

Εάν οποιαδήποτε από αυτές τις οδηγίες δεν είναι κατανοητή, ανατρέξτε στο εγχειρίδιο ή επικαιρονηστέ μαζί μας πριν προχωρήσετε.

### **A DANGER** Ασφάλεια, όλα τα προϊόντα:

Υποδεικνύει άμεση κατάσταση κινδύνου που αν δεν αποφευχθεί, μπορεί να προκαλέσει θάνατο ή σοβαρό τραυματισμό.



Υποδεικνύει δυνητικά επικίνδυνη κατάσταση που αν δεν αποφευχθεί, μπορεί να προκαλέσει θάνατο ή σοβαρό τραυματισμό.



Υποδεικνύει δυνητικά επικίνδυνη κατάσταση που αν δεν αποφευχθεί, μπορεί να προκαλέσει μικρό ή ήπιο τραυματισμό. Μπορεί να χρησιμοποιηθεί και ως προειδοποίηση μη ασφαλών πρακτικών.



για την προειδοποίηση του χρήστη σχετικά με την παρουσία μην-μονωμένης "επικίνδυνης τάσης" μέσα στο περίβλημα του ψύκτη. Το μέγεθος της τάσης είναι αρκετά σημαντικό ώστε να αποτελέσει κίνδυνο ηλεκτροπληξίας.



υποδεικνύει την παρουσία ζεστών επιφανειών



υποδεικνύει ανάνηψη του εγχειριδίου.

Μη χρησιμοποιείτε τον εξοπλισμό ως αποστειρωμένη συσκευή ή συσκευή συνδεδεμένη με τον ασθενή. Επιπλέον, ο εξοπλισμός δεν έχει σχεδιαστεί για χρήση στην Κατηγορία I, II ή III Επικίνδυνες Θέσεις από τον Εθνικό Ηλεκτρολογικό Κώδικα.

Ο εξοπλισμός έχει σχεδιαστεί για χρήση σε εσωτερικούς χώρους. Μην τοποθετείται ποτέ σε τοποθεσία με υπερβολική θερμότητα, υγρασία, ανεπαρκή αερισμό ή διαβρωτικά υλικά. Ανατρέξτε στις λειτουργικές παραμέτρους του εγχειριδίου.

Συνδέστε τον εξοπλισμό σε κατάλληλα γειωμένη έξοδο.

Τα ψυκτικά που χρησιμοποιούνται είναι βαρύτερα από τον αέρα και εάν υπάρχει διαρροή, θα αντικαταστήσουν το οξυγόνο και θα προκαλέσουν απώλεια αισθήσεων. Η επαφή με ψυκτικό διαρροής θα προκαλέσει εγκαύματα στο δέρμα. Ανατρέξτε στην πινακίδα για τον τύπο του ψυκτικού που χρησιμοποιείται και το τρέχον φύλλο Δεδομένων Ασφαλείας Η.Π.Α (SDS) γνωστά ως MSDS και το φύλλο Δεδομένων Ασφάλειας Ε.Ε. για περισσότερες πληροφορίες.

Μετακινήστε τον εξοπλισμό με προσοχή. Ξαφνικά τραντάγματα ή πτώσεις ενδέχεται να προκαλέσει βλάβες στα εξαρτήματα. Πάντα σβήνεται τον εξοπλισμό και αποσυνδέστε τον από την παροχή τάσης, πριν από τη μετακίνησή του.

Ποτέ μη λειτουργείτε εξοπλισμό που έχει υποστεί βλάβη ή παρουσιάζει διαρροές.

Ποτέ μη χρησιμοποιείτε εύφλεκτα ή διαβρωτικά υγρά. Χρησιμοποιήστε μόνο εγκεκριμένα υγρά που αναφέρονται στο εγχειρίδιο. Πριν χρησιμοποιήσετε οποιοδήποτε υγρό ή κατά τη διαδικασία της συντήρησης όπου η επαφή με το υγρό είναι πιθανή, ανατρέξτε στα Φύλλα Δεδομένων Ασφαλείας SDS και EC για περισσότερες πληροφορίες.

Πάντα σβήνεται τον εξοπλισμό και αποσυνδέστε τον από την παροχή τάσης, πριν από τη μετακίνησή του.

Για σέρβις και επισκευές απευθυνθείτε σε εξειδικευμένο τεχνικό.

Αποθηκεύστε τον εξοπλισμό σε θερμοκρασία μεταξύ -25°C και 60°C (με τη συσκευασία) και σε σχετική υγρασία <80%.

Η θέση εκτός λειτουργίας θα πρέπει να εκτελείται από εξειδικευμένο προμηθευτή με τη χρήση πιστοποιημένου εξοπλισμού. Όλοι οι κανονισμοί εν ισχύ θα πρέπει να τηρούνται.

Οι διαδικασίες εγκατάστασης, λειτουργίας ή συντήρησης εκτός από εκείνες που περιγράφονται στο εγχειρίδιο ενδέχεται να προκαλέσουν επικίνδυνες καταστάσεις και ακύρωση της εγγύησης του κατασκευαστή.

Ποτέ μην εφαρμόζετε τάση γραμμής σε οποιαδήποτε σύνδεση επικοινωνίας επί του ψύκτη.

Αν οι ψύκτες και οι γραμμές επεξεργασίας υγρού δεν είναι πλήρως γεμάτα, ενδέχεται να προκληθεί βλάβη στην αντλία του ψύκτη. Αποφύγετε την υπερχέλιση, τα υγρά διαστέλλονται όταν θερμαίνονται.

Στη διάταξη ThermoFlex, πριν την αντικατάσταση του περιβλήματος της δεξαμενής, βεβαιωθείτε ότι μπύλια του σωλήνα σκόπευσης έχει ασφαλιστεί στη θέση της.

Στο ThermoFlex900-5000, μη λειτουργείτε τον ψύκτη αν δεν έχει εγκατασταθεί ο διαχυτής υγρού της δεξαμενής.

Εάν ο ψύκτης σας έχει εφοπλιστεί με αντλία θετικού εκποτισματος (P1 ή P2), βεβαιωθείτε ότι οι υδραυλικές σωληνώσεις και οι συνδέσεις έχουν ρυθμιστεί έτσι ώστε να έχουν αντοχή σε ελάχιστο 185 psi.

Μη χρησιμοποιείτε αντιψυκτικό αυτοκινήτου. Τα αντιψυκτικά του εμπορίου περιέχουν πυρίτιο που προκαλεί ζημιά στις στεγανοποιήσεις.

Για την αποτροπή δημιουργίας πάγου/επικάλυψης στην πλάκα του εναλλάκτη, οι ψύκτες,

ThermoFlex7500-24000 απαιτούν τη χρήση 50/50 EG/νερού ή 50/50 P/G/νερό κάτω της θερμοκρασίας διαδικασίας των 10°C. Κατά τη χρήση μειγματος υγρού EG/νερού ή PG/νερού, ελέγχετε τη συγκέντρωση και το pH σε τακτά χρονικά διαστήματα.

Οι αλλαγές σε συγκέντρωση και pH ενδέχεται να επηρεάσουν τις επιδόσεις του συστήματος. Μη χρησιμοποιείτε φυσίγγιο φίλτρου απιονισμού (DI) με αναστολέα EG ή αναστολέα PG.

Ένα φίλτρο DI θα αφαιρέσει τους αναστολείς από το διάλυμα, καθιστώντας το υγρό αναποτελεσματικό κατά την προστασία από τη διάβρωση. Επίσης, οι αναστολείς αυξάνουν την αγωγιμότητα του υγρού.

Τα βιοκτόνα είναι διαβρωτικά και μπορούν να προκαλέσουν μη αναστρέψιμη βλάβη στα μάτια και εκκτώματα στο δέρμα. Είναι βλαβερά κατά την εισπνοή, την κατάποση και την απορρόφηση από το δέρμα. Ανατρέξτε στο τρέχον φύλλο SDS του κατασκευαστή.

Για να αποτρέψετε βλάβες στην πλάκα εναλλάκτη του ψύκτη, οι φυγόκεντρες αντλίες απαιτούν ελάχιστη ροή 4,0 gpm (15,1 lpm).

Ο μη καθαρισμός ή η μη αντικατάσταση του φίλτρου συμπυκνωτή προκαλεί απώλεια ικανότητας ψύξης και θα οδηγήσει σε πρώιμη αποχία του συστήματος ψύξης. Για καλό καθαρισμό αφαιρέστε την εμπρός γρίλια της συναρμολογίας.

Σε αερόψυκτους ψύκτες το πλαίσιο του συμπυκνωτή και τα πτερύγια που βρίσκονται πίσω από την εμπρός σχάρα είναι πολύ κοφτερά.

Εκτός από την αερόψυκτη συναρμολογία της γρίλιας, ποτέ μην λειτουργείτε τον ψύκτη με βγαλμένα τα πλαίσια.

Οι υδρόψυκτοι ψύκτες ThermoFlex900-5000 έχουν έναν ανεμιστήρα με κοφτερές λεπίδες, βεβαιωθείτε ότι ο ψύκτης είναι σβηστός πριν αφαιρέσετε την εμπρός γρίλια.

### Προοριζόμενη χρήση, ψύκτες επανακυκλοφορίας:

Οι ψύκτες επανακυκλοφορίας Thermo Scientific έχουν σχεδιαστεί για να παρέχουν συνεχή παροχή υγρού σε σταθερή θερμοκρασία και ροή. Ο ψύκτης αποτελείται από ένα αερόψυκτο ή υδρόψυκτο σύστημα ψύξης, έναν εναλλάκτη θερμότητας, μία αντλία επανακυκλοφορίας, μία δεξαμενή υγρού και έναν ελεγκτή μικροεπεξεργαστή.



Οι ψύκτες έχουν σχεδιαστεί για συνεχόμενη λειτουργία σε εσωτερικούς χώρους σύμφωνα με τις διαδικασίες και τις απαιτήσεις που ορίζει το παρόν εγχειρίδιο.

### Εγκατάσταση, Διατάξεις ψύξης επανακυκλοφορίας:

Τοποθετήστε τη διάταξη ψύξης έτσι ώστε να είναι κοντά, με εύκολη στη διάταξη αποσύνδεσης.

Ο ψύκτης προορίζεται για χρήση σε αντίστοιχη έξοδο.

Βεβαιωθείτε ότι όλα τα πώματα συσκευασίας στις υδραυλικές σωληνώσεις έχουν αφαιρεθεί πριν την εγκατάσταση.

Οι συνδέσεις υγρού της διαδικασίας βρίσκονται στο πίσω μέρος του ψύκτη και έχουν ετικέτα (ΕΞΟΔΟΣ ΔΙΑΔΙΚΑΣΙΑΣ) και  και (ΕΙΣΟΔΟΣ ΔΙΑΔΙΚΑΣΙΑΣ). Συνδέστε το  στην είσοδο του υγρού της εφαρμογής σας. Συνδέστε το  στην έξοδο του υγρού της εφαρμογής σας.

Για υδρόψυκτους ψύκτες συνδέστε το  (ΕΙΣΟΔΟΣ ΧΡΗΣΗΣ) στην παροχή νερού χρήσης. Συνδέστε την  (ΕΞΟΔΟ ΧΡΗΣΗΣ) στην επιστροφή νερού χρήσης ή στην αποστράγγιση.

Πριν την έναρξη του ψύκτη, ελέγξτε με προσοχή την επικοινωνία και τις ηλεκτρικές και υδραυλικές συνδέσεις.



## Olulised ohutusjuhised Ringlusega jahutid

Kui mistahes juhised ei ole arusaadavad, siis enne jätkamist vaadake kasutu sjuhendit.

### Ohutus, kõik tooted:

**DANGER** tähistab tõsise ohukorda, millele tähelepanu pööramata jätmise võib põhjustada surma või tõsise vigastuse.

**WARNING** tähistab potentsiaalselt ohulikku olukorda, millele tähelepanu pööramata jätmine võib põhjustada surma või tõsise vigastuse.

**CAUTION** tähistab potentsiaalselt ohulikku olukorda, millele tähelepanu pööramata jätmine võib põhjustada väiksema või keskmise raskusega vigastuse. Seda kasutatakse ka ohulikust tegevusest hoiatamiseks.

 ettenähtud kasutaja hoiatamiseks jahuti korpusel olevast isoleerimata "ohulikust pingest".  
Pinge tugevus on piisav elektrilöögi tekitamiseks.

 tähistab kuumade pindade olemasolu.

 tähistab kasutusjuhendi vaatamise vajadust.

Ärge kasutage seadmeid steriilsete seadmetena või patsiendiga ühendatavate seadmetena. Lisaks eelnevale, ei ole seadmed ettenähtud kasutamiseks I, II või III klassi ohlikes rakendustes vastavalt NEC nõuetele.

Seadmed on ettenähtud kasutamiseks ainult siseruumides. Ärge kunagi paigutage ülemaärse kuumusega, niiskusega, ebapiisava ventilatsiooniga kohtadesse või soovitatavate materjalide lähedale. Vaadake tööparameetreid kasutusjuhendist.

Ühendage seade nõuetekohaselt maandatud seinapistikuga.

Kasutatavad jahutusained on õhust raskemad ning tõrjuvad lekke korral õhu välja ning võivad põhjustada meeleärritust. Lekkiva jahutussainega kokkupuutumine põhjustab nahapõletusi. Lisateabeks kasutatava jahutusaine kohta vaadake ringluspumba andmeplaati ja tootja kõige hilisemat ohutuskaarti (SDS, MSDS, EL ohutuskaart).

Ligutage seadet ettevaatlikult. Ootamatud põrutused ja kukkumised võivad kahjustada seadme komponente. Enne seadme liigutamist lülitage seade alati välja ja ühendage lahti toitevõrgust.

Ärge kasutage kunagi kahjustatud või lekkivaid seadmeid.

Ärge kasutage kunagi süttimisohutikke või soovitavaid vedelikke. Kasutage ainult kasutusjuhendis heakskiidetud vedelikke. Enne mistahes vedelike kasutamist või hooldustööde läbiviimist vaadake lisateabeks tootja kõige hilisemat ohutuskaarti (SDS, MSDS, EL ohutuskaart).

Enne seadme liigutamist lülitage seade alati välja ja ühendage lahti toitevõrgust.

Hooldamisel ja remondi korral pöörduge kogemustega tehniku poole.

Hoidke seadmeid temperatuurivahemikus -25°C kuni 60°C (pakendis) ja <80% suhtelise niiskuse juures.

Kasutusest eemaldamisel pöörduge sertifitseeritud seadmeid kasutava kogemustega ettevõtte poole.

Järgige kõiki kehtivaid eeskirju.

Kasutusjuhendis kirjeldamata paigaldamis-, töötamis- või hooldusprotseduurid võivad kaasa tuua ohuliku olukorra ning muudavad garantii kehtetuks.

Ärge kunagi rakendage võrgupinget jahuti mistahes andmesideühendustele.

Täielikult täitmata jahuti ja töövedeliku torustik või põhjustada jahuti pumba kahjustamist. Vältige ületäitmist, soojenemisel vedelikud paisuvad.

Enne ThermoFlex seadme mahuti katte asendamist veenduge, et mahuti vaatoru kuuli kork on kindlalt oma kohas.

Ärge kasutage ThermoFlex900-5000 seadmel jahuti enne, kui on paigaldatud mahuti vedeliku difuuser.

Kui Teie jahuti on varustatud mahtpumbaga (P1 või P2), siis veenduge, et Teie seadme torustik ja liitmikud taluvad vähemalt 185 psi survet.

Vältige MD pumpadega varustatud Meriin jahutitel torustikus jahutusvedeliku voolu täielikku takistamist. Tühjalt töötav pump kahjustab liitekohta ning võib põhjustada pumba kahjustamist.

Ärge kasutage sõidukite jahutusvedelikku. Kaubanduses kättesaadavad jahutusvedelikud sisaldavad silikaate, mis kahjustavad pumba tihendeid.

Plaatsoojusvaheti külmumise ärahoidmiseks vajavad ThermoFlex7500-24000 jahutid temperatuuridel 10°C alla töötetemperatuuri 50/50 EG/vesi või 50/50 PG/vesi kasutamist.

Kui kasutate töövedelikuna EG/vesi või PG/vesi segu, siis kontrollige regulaarselt kontsentratsiooni ja pH-taset. Kontsentratsiooni ja pH-taseme muutused võivad mõjutada süsteemi töötamist.

Ärge kasutage deioniseerimise (DI) filtrikassetti koos inhibeeritud EG-ga või inhibeeritud PG-ga. DI filter eemaldab lahusest inhibiitorid, vähendades vedeliku korrosioonivastast mõju. Lisaks sellele suurendavad inhibiitorid vedeliku juhitavust.

Nad on ohulikud sissehingamisel, allaneelamisel ja imendumisel läbi naha. Vaadake tootja kõige hilisemat ohutuskaarti.

Jahuti plaatsoojusvaheti kahjustamise ärahoidmiseks peab tsentrifugaalpumba minimaalne voolukiirus olema 4,0 gpm (15,1 liitrit/minutis).



Kondensaatori filtri puhastamise/asendamise nõuete mittejärgimine põhjustab jahutusvõimsuse vähenemise ja jahutussüsteemi enneaegse purunemise. Põhjalikuks puhastamiseks eemaldage esivõre.

Õhkjahutusega jahutite esivõre taga asuva kondensaatori raamistik ja ribad on väga teravad.

Ärge kunagi kasutage eemaldatud paneelidega jahutit.

ThermoFlex900-5000 vesijahutusega jahutitel on teravate labadega ventilator, enne esivõre eemaldamist veenduge, et jahuti on välja lülitatud.

### **Kasutuseesmärk, ringlusega jahutid:**

Thermo Scientific ringlusega jahutid on ettenähtud pideva temperatuuriga ja voolukiirusega vedeliku voolamise tagamiseks. Jahuti koosneb õhkjahutusega või vesijahutusega jahutussüsteemist, soojusvahetist, ringluspumbast, töövedeliku mahutist ja mikroprotsessoriga juhtimissüsteemist.





Jahutid on ettenähtud pidevaks töötamiseks sisetingimuteses vastavalt kasutusjuhendis sätestatud protseduuridele ja nõuetele.

### **Paigaldamine, ringlusega jahutid:**

Paigutage jahuti nii, et selle väljalülitamise seadmele on lihtne juurde pääseda.

Jahutile peab olema ettenähtud eraldi seinakontakt.

Veenduge, et torustiku transportikorgid on enne paigaldamist eemaldatud.

Töövedeliku ühendused asuvad jahuti tagaosas ning on tähistatud  (PROCESS OUTLET) (sisend) ja  (PROCESS INLET) (väljund). Ühendage  oma seadme vedeliku sisendiga. Ühendage  oma seadme vedeliku väljundiga.

Vesijahutusega jahutite korral ühendage  (FACILITY INLET)(seadme sisend) oma seadme veevarustususega. Ühendage  (FACILITY OUTLET) (seadme väljund) oma seadme veetagastusega või äravooluga.

Enne jahuti käivitamist kontrollige üle kõik kasutatavad andmesideühendused, elektriühendused ja toruühendused.

## Olennaiset turvaohjeet Kiertojäähdyttimet

Jos nämä ohjeet eivät ole selvä, viittaa ohjekirjaan tai ota meihin yhteyttä ennen kuin jatkat eteenpäin.

### Turvallisuus, kaikki tuotteet:

**DANGER** osoittaa välittömää vaaratilannetta, joka johtaa kuolemaan tai vakavaan loukkaantumiseen, ellei sitä välitetä.

**WARNING** osoittaa potentiaalisen vaaratilanteen, joka voi johtaa kuolemaan tai vakavaan loukkaantumiseen, ellei sitä välitetä.

**CAUTION** osoittaa potentiaalisen vaaratilanteen, joka saattaa aiheuttaa pienen tai kohtalaisen vamman, ellei sitä välitetä. Sitä käytetään varoittamaan myös vaarallisista tavoista.

 tarkoitettu varoittamaan käyttäjää eristämättömästä "vaarallisesta jännitteestä" jäähdyttimen kotelo sisällä. Jännitteen voimakkuus on merkittävä sähköiskuvaaran aiheuttamiseksi.

 osoittaa kuumien pintojen paikallaoloa.

 osoittaa ohjekirjan lukemiseen liittyvää velvoitusta.

Älä käytä laitetta steriiliinä varusteena tai potilaaseen yhdistettynä. Laitetta ei ole suunniteltu käytettäväksi National Electrical Code -sääntöjen mukaisesti I, II tai III luokan tiloissa.

Laitte on tarkoitettu käytettäväksi vain sisätiloissa. Älä koskaan sijoita sitä paikkoihin joissa esiintyy iliallisen kuumuutta, kosteutta, riittämätön tuuletus tai syövyttäviä materiaaleja. Viittaa ohjekirjaan käyttöparametrejä varten.

Liitä laite maadoitettuun pistorasiaan.

Käytetyt jäähdytysaineet ovat ilmaan verrattuna painavampia, ja jos vuotoa esiintyy, se korvaa hapen aiheuttamalla tejon menettämisen. Kosketus vuotavaan jäähdytysaineeseen aiheuttaa palovammoja.

Lisätietoja varten viittaa kiertoilimen arvokilpeen koskien käytettyä jäähdytysainetta ja valmistajan päivitetyihin käyttöturvallisuustietoihin (US Safety Data Sheet - SDS), jotka tunnetaan aiemmin nimellä MSDS, sekä EU:n käyttöturvallisuustietoihin.

Siirrä laitetta varovaisesti. Äkilliset tärinäkset tai putoamiset voivat vahingoittaa siihen kuuluvia osia.

Sammuta laite ja kytke se irti jännitelähteestä ennen sen liikkuttamista.

Älä koskaan käytä laitetta jos se on vahingoittunut tai siinä esiintyy vuotoja.

Älä koskaan käytä tulenarkoja tai syövyttäviä nesteitä. Käytä vain ohjekirjassa lueteltuja hyväksytyjä nesteitä. Ennen nesteiden käyttöä tai huoltotoimenpiteiden suorittamista, joihin liittyy kosketus nesteeseen, viittaa valmistajan päivitettiin käyttöturvallisuustietoihin (US Safety Data Sheet - SDS) ja EU:n käyttöturvallisuustietoihin lisätietoja varten.

Sammuta laite ja kytke se irti jännitelähteestä aina ennen sen liikkuttamista.

Jätä korjaus- ja huoltotyöt pätevän teknikon tehtäväksi.

Säilytä laitetta -25 °C - 60 °C lämpötilassa (pakkauksen kanssa), ja suhteellisen kosteuden ollessa <80 %.

Käytöstä poistaminen on suoritettava yksinomaan pätevän jälleenmyyjän toimesta sertifioituja varusteita käyttämällä. Noudata kaikkia voimassa olevia määräyksiä.

Muiden kuin tässä ohjekirjassa kuvattujen asennus-, käyttö- tai huoltotoimenpiteiden suorittaminen voi aiheuttaa vaarallisen tilanteen ja mitätöidä valmistajan myöntämän takuun.

Älä koskaan syötä injannitettua jäähdyttimessä oleviin yhteysliitoksiin.

Nesteen syöttöinjoihin ja jäähdyttimen vajaan täyttö voi vahingoittaa jäähdyttimen pumppua. Vältä kuitenkin ylitäyttöä, sillä nesteet laajenevat kun niitä kuumennetaan.

Ennen ThermoFlexissä olevan säiliökotelon vaihtoa varmista, että säiliön tarkastusputken pyöreää pidike on kiinnitetty kunnolla paikoilleen.

Älä käytä jäähdytintä ThermoFlex900-5000:ssa ennen kuin säiliönesteen jakolaite on asennettu.

Jos jäähdytin on varustettu positiivisella tilavuuspumpulla (P1 tai P2), varmista, että sovellukseen kuuluvat putket ja kiinnikkeet kestävät vähintään 185 psi:n paineen.

Älä käytä ajoneuvoille tarkoitettuja pakkasnestettä. Myynnissä olevat pakkasnestee sisältävät silikaatteja, jotka vahingoittavat pumpun tiivisteitä.

Estääksesi levyjämmönvaihtimen jäätymistä ThermoFlex7500-24000 -jäähdyttimet vaativat 50/50 EG/vesi tai 50/50 PG/vesi käyttöä alle 10 °C prosessilämpötilassa.

Kun EG/vesi- tai PG/vesi-nesteseosta käytetään, tarkista säännöllisin väliajoin nesteen pitoisuus ja pH-arvo. Pitoisuuden ja pH-arvon muutokset voivat vaarantaa järjestelmän suorituskykyä.

Älä käytä deionisoivaa (DI) suodatuspatruunaa estetyin EG:n tai PG:n kanssa. DI-suodatin poistaa inhibiittorit nesteestä, tekemällä nesteestä tehottoman syöpymistä vastaan.

Biosidit ovat syövyttäviä ja voivat aiheuttaa parantumatonta silmävauriota ja palovammoja. Ne ovat vaarallisia jos niitä hengitetään, niellään tai ne imeytyvät ihon kautta. Viittaa valmistajan päivitetyihin SDS-asiakirjoihin.

Estääksesi jäähdyttimen levyjämmönvaihtimen vahingoittumista, keskipakopumput vaativat vähintään 4,0 gpm (15,1 lpm) virtausta.

Lauhduttimen suodatimen puhdistamisen/vaihdon suorittamatta jättäminen aiheuttaa jäähdytyskapasiteetin vähenemistä ja johtaa jäähdytysjärjestelmässä syntyviin ennenaikaisiin vikoihin. Perusteellista puhdistusta varten, irrota eturitiläyksikkö.

Ilmajäähdyeisissä jäähdyeimissä eturitiäyksikön takana sijaitsevat lauhdyeimen siivekkeet ja kehikko ovat erittäin teräviä.

Älä koskaan käynnistä jäähdyeintä kun paneelit on irrotettu, lukuun ottamatta ilmajäähdyeistä ritiliäyksikköä.

Vesijäähdyeisissä ThermoFlex900-5000 -jäähdyeimissä on terävillä lavoilla varustettu tuuletin. Varmista, että jäähdyein on sammutettu ennen eturitiän irrottamista.

### **Käyttötarkoitus, kiertojäähdyeimet:**

Thermo Scientific kiertojäähdyeimet on suunniteltu jatkuvan nesteen syöttöön vakaassa lämpötilassa ja virtausarvossa. Jäähdyein koostuu ilma- tai vesijäähdyeisistä jäähdyeysjärjestelmästä, lämmönvaihtimesta, kiertopumpusta, prosessinesteen säiliöstä ja mikroprosessori-ohjaimesta.

Jäähdyeimet on suunniteltu jatkuvaan käyttöön sisätiloissa tässä ohjekirjassa määritelyjen menettelyjen ja vaatimusten mukaisesti.

### **Asennus, kiertojäähdyeimet:**

Aseta jäähdyein siten, että siihen kuuluvaan irtikytkentälaitteeseen päästään helposti.

Jäähdyeintä on käytettävä yksinomaan sen käyttöön tarkoitettulla pistorasialla.

Varmista, että kaikki läheyksessä käytetyt putkitulpat on irrotettu ennen sen asennusta.

Prosessinesteen liitännät sijaitsevat jäähdyeimen takaosassa ja ne on merkitty  (PROCESS OUTLET) ja  (PROCESS INLET). Liitä  sovelluksessasi olevaan nesteen sisäänmenoon.

Liitä  sovelluksessasi olevaan nesteen ulostuloon.

Vesijäähdyeisissä jäähdyeimissä, liitä  (FACILITY INLET) järjestelmän vedensyöttöön. Liitä

 (FACILITY OUTLET) järjestelmän paluuveteen tai viemäriin.

Ennen jäähdyeimen käynnistystä, tarkista kaikki yhteyslinjat sekä sähkö- ja vesiliitokset.



## Treoracha Riachtanacha Sábháilteachta Fuarthóirí Athfhillteacha

Má tá aon treoir ann nach dtuigtear, ceadaiigh an lámhleabhar nó déan teagmháil linn sula dtéann tú níos faide.

### Sábháilteacht, gach táirge:



Iéiríonn sé staid ghuaiseach as a leanfaidh bás nó tromghortú, mura seachnaítear í.



Iéiríonn sé staid ghuaiseach, a bhféadfadh bás nó tromghortú a bheith ina thoradh air, mura seachnaítear í.



Iéiríonn sé staid ghuaiseach, as a leanfaidh mionghortú nó dochar measartha, mura seachnaítear í. Úsáidtear é, leis, chun rabhadh a thabhairt i gcás cleachtais neamhshábháilte.



ceaptha leis an úsáideoir a chur ar an eolas maidir le “voltas contúirteach” neamhinslithe laistigh d’imfháil an fhuarthóra. Tá méid an voltais suntasach a dhóthain le bheith ina bhaol turrainge leictirí.



Iéiríonn sé dromchlaí te.



Iéiríonn sé gur chóir an lámhleabhar a léamh.

Ná húsáid an trealamh mar ghléas steiriúil ná mar ghléas a nasctar le hothar. Lena chois sin, níor ceapadh an trealamh lena úsáid i Láithreacha Guaiseacha Aicme I, II nó III mar a shainmhínítear sa Chód Náisiúnta Leictreach.

Trealamh atá ceaptha le húsáid istigh amháin. Ná suigh riamh é in áit ina bhfuil teas iomarcach, taisce, aerú neamhdhóthanach nó ábhair chreimneacha. Ceadaiigh an lámhleabhar go bhfeice tú na paraiméadair oibriúcháin.

Ceangail an trealamh d’asraon atá talmhaithe i gceart.

Is airde ná aer na cuisneáin a úsáidtear, agus má bhíonn sceitheadh ann, gabhfaidh siad áit na hocsaigne as a leanfaidh cailliúint comhfheasa. Dófar craiceann má bhíonn teagmháil idir craiceann agus cuisneán atá ag sceitheadh. Féach ainmhláta an dáileora go bhfeice tú an cineál cuisneáin a úsáidtear agus ansin féach Leathanach Sonraí Sábháilteachta SA is déanaí an déantóra, an rud a dtugtaí an MSDS air cheana, agus Leathanach Sonraí Sábháilteachta an AE chun breis eolais a fháil.

Bí cúramach agus tú ag bogadh an trealaimh. Is féidir le croitheadh nó isliú tobann na comhpháirteanna a dhamáistiú. Cas an trealamh as i gconáil agus dícheangail é den voltas soláthair sula mbogann tú é.

Ná hoibrigh riamh trealamh damáistithe nó trealamh atá ag sceitheadh.

Ná húsáid leacht inadhainte nó creimneach riamh. Ná húsáid ach na leachtanna ceadaithe atá liostaithe sa lámhleabhar. Sula n-úsáidtear aon leacht nó sula ndéantar cothabháil ina bhféadfaí teagmháil a dhéanamh leis an leacht, ceadaiigh Leathanach Sonraí Sábháilteachta SA is déanaí an déantóra agus Leathanach Sonraí Sábháilteachta an AE chun breis eolais a fháil.

Cas an trealamh as i gconáil agus dícheangail é den voltas soláthair sula mbogann tú é.

Iarr ar theicneoir cáilithe gach seirbhísiú agus deisiú a dhéanamh.

Stóráil an trealamh sa raon teochta -25°C go 60°C (in éineacht leis an bpacáistiú), agus i dtaiseacht choibhneasta <80%.

Níor chóir ach do dhéileálai cáilithe, a úsáideann trealamh deimhnithe, an gléas a dhíchoimisíú. Ní mór cloí le gach rialachán atá i bhfeidhm.

Féadfaidh staid ghuaiseach agus cur ar neamhní bharánta an déantóra a bheith ina thoradh ar fheidhmíú níosanna imeachta suiteála, oibriúcháin nó cothabhála seachas iad siúd a ndéantar cur síos orthu sa lámhleabhar.

Ná húsáid voltas líne riamh le haon cheann de na naisc chumarsáide ar an bhfuarthóir.

D’fhéadfaí caidéal an fhuarthóra a dhamáistiú mura líontar an fuarthóir agus na línte leachta próisis go hiomlán. Seachain róilíonadh, fairsingíonn leachtanna tar éis iad a théamh.

Ar ThermoFlex, sula gcuirtear cásáil an taiscumair ar ais, cinntigh go bhfuil stopallóir iathróide thiúb radhairc an taiscumair deingnithe ina áit.

Ná hoibrigh an fuarthóir ThermoFlex900-5000 mura bhfuil idirleatóir leachta an taiscumair suiteáilte.

Ar ThermoChill, ná líon os cionn na bile nó sceitfidh an leacht amach as barr an umair ar chomhpháirteanna an fhuarthóra.

Má tá d’fhuarthóir trealmhaithe le caidéal dearfach dlíáithrúcháin (P1 nó P2), cinntigh go bhfuil línte agus feisitis phluiméireachta d’fheidhmíúcháin rátáilte chun ar a laghad 185 psi a sheasamh.

Ná húsáid oibreán frithreo uathghluaisneach. Tá sileacáit in oibreán frithreo uathghluaisneach a dhamáistíonn séalai caidéil.

Chun reoigloiniú an mhalartóra plátaí a sheachaint, is gá, i gcás fhuarthóirí ThermoFlex7500-24000, 50/50 EG/uisce nó 50/50 PG/uisce faoi bhun 10°C de theocht próisis a úsáid.

Agus meascán leachta próisis de EG/uisce nó PG/uisce a úsáid, seiceáil túchan an leachta agus an pH ar bhonn rialta. Is féidir le hathruithe ar thiúchan agus ar pH difear a dhéanamh d’fheidhmíocht córais.

Ná húsáid cartús scagaire dí-ianúcháin (DI) le EG Coiscithe nó PG Coiscithe. Bainfidh scagaire DI coscairí den tuaslagán a fhágfaidh an leacht neamhéifeachtach mar chosaint ar chreimeadh. Ina theannta sin, méadaíonn coscairí seoltacht leachta.

Is oibreáin chreimneacha iad bithicídí agus is féidir leo damáiste doleigheasta a dhéanamh don tsúil agus an craiceann a dhó. Déanann siad damáiste má dhéantar iad a anáilú, a shlogadh nó a ionsú tríd an gcráiceann. Ceadaigh an SDS is déanaí ón déantóir.

Chun damáiste do mhalaratóir plátaí an fhuarthóra a chosc, teastaíonn ráta íosta sreafa 4.0 gpm (15.1 lpm) ó chaidéil lártheifeacha.

Mura ndéantar an scagaire comhdhlúthadáin a ghlanadh/a athchur, cailltear cumas fuarthóra agus d'fhéadfadh an córas fuaraithe teip roimh am. Chun glanadh iomlán a dhéanamh, bain cóimeáil na greille tosaigh.

Ar fhuarthóirí aerfhuaraithe bíonn an fhrámáil agus na heití atá suite laistigh de chóimeáil na greille tosaigh an-ghéar.

Seachas an chóimeáil ghreille aerfhuaraithe, ná hoibrigh an fuarthóir niamh agus aon cheann de na painéil bainte.

Tá lanna géara sa bhfean i bhfuarthóirí uiscefhuaraithe ThermoFlex900-5000, féach chuige go bhfuil an fuarthóir casta as sula mbaintear an ghreille thosaigh.

### Úsáid Cheaptha, Fuarthóirí Athfhillteacha:





Dearadh fuarthóirí athfhillteacha Thermo Scientific le soláthar leanúnach leachta a sholáthar ag teocht agus ar ráta sreafa seasmhach. Is éard atá san fuarthóir córas cuisniúcháin aerfhuaraithe nó uiscefhuaraithe, teasmhalaratóir, caidéal athfhillteach, taiscumar leachta próisis agus rialtóir micreaphróiseálaí.

Tá fuarthóirí ceaptha le haghaidh oibriú leanúnach agus le húsáid laistigh de réir na nósanna imeachta agus na riachtanas atá luaite sa lámhleabhar a ghabhann leis.

### Le Fuarthóirí Athfhillteacha a Shuiteáil:

Suigh an fuarthóir gar dá ghleas dícheangail, agus sa tsíle go bhfuil fáil ar an ngléas sin go héasca. Tá an fuarthóir ceaptha le húsáid ar asraon tiomnaithe.

Cinntigh go mbaintear gach plocóid seolta líne pluiméireachta sula ndéantar an tsuiteáil.

Tá na naisc leachta próisis suite ar chúil an fhuarthóra agus tá siad lipéadaithe  (PROCESS OUTLET (ASRAON PRÓISIS)) agus  (PROCESS INLET (IONRAON PRÓISIS)). Ceangail an  leis an ionraon leachta ar d'fheidmiúchán. Ceangail an  leis an asraon leachta ar d'fheidmiúchán.

I gcás fuarthóirí uiscefhuaraithe, ceangail an  (FACILITY INLET (IONRAON SAORÁIDE)) le soláthar uisce do shaoráide. Ceangail an  (FACILITY OUTLET (ASRAON SAORÁIDE)) le fillleadh nó draein uisce do shaoráide.

Sula dtosaítear an fuarthóir, seiceáil faoi dhó gach cumarsáid infheidhmíthe, agus gach nasc leictreach agus pluiméireachta.



## Osnovne sigurnosne uput Cirkulirajući rashladni uređaji

Ako ne razumijete bilo koje od ovih uputa, pogledajte priručnik ili nas kontaktirajte prije nego što nastavite.

**Sigurnost, svi proizvodi:**

 označava neposrednu opasnost koja će, ako se ne izbjegne, uzrokovati smrt ili tešku ozljedu.

 označava moguću opasnu situaciju koja, ako se ne izbjegne, može uzrokovati smrt ili tešku ozljedu.

 označava moguću opasnu situaciju koja, ako se ne izbjegne, može uzrokovati manju ili srednje tešku ozljedu. Također se može koristiti da upozori na nesigurne radnje.

 upozorava korisnika na prisutnost neizoliranog „opasnog napona“ unutar kućišta rashladnog uređaja. Napon je dovoljno velik da predstavlja opasnost od strujnog udara.

 ukazuje na prisutnost vrućih površina.

 ukazuje da je potrebno pročitati priručnik.

Nemojte koristiti opremu kao sterilni proizvod ili proizvod povezan na pacijenta. Pored toga, oprema nije predviđena za upotrebu na opasnim lokacijama klase I, II ili III prema definicijama Nacionalnog električnog standarda (engl. National Electrical Code).

Oprema je predviđena isključivo za upotrebu u zatvorenim prostorima. Nikad je nemojte postavljati gdje je prisutna prekomjerna toplota, vlažnost, neodgovarajuće prozračivanje ili nagrizajući materijali. Radni parametri navedeni su u priručniku.

Povežite opremu na pravilno uzemljenu utičnicu.

Korištena sredstva za hlađenja teža su od zraka i, ako dođe do curenja, zamijenit će kisik te dovesti do gubitka svijesti. Kontakt sa sredstvom za hlađenje koje curi uzrokuje opekline. Pogledajte natpisnu pločicu cirkulatora za vrstu korištenog sredstva za hlađenje, a zatim potražite dodatne informacije u najnovijem sigurnosno-tehničkom listu za SAD (engl. Safety Data Sheet; SDS), ranije poznatom kao MSDS, kao i sigurnosno-tehničkom listu za EU.

Oprezno pomjerajte opremu. Naglo dimanje ili ispuštanje opreme može oštetiti njene komponente. Prije pomjeranja oprema uvijek je isključite i iskopčajte iz napona izvora napajanja.

Nikad nemojte koristiti oštećenu opremu ili opremu koja propušta.

Nikad nemojte koristiti zapaljive ili nagrizajuće tekućine. Koristite samo odobrene tekućine navedene u priručniku. Prije korištenja bilo kakve tekućine ili obavljanja postupaka održavanja u kojima će vjerojatno doći do kontakta s tekućinom, potražite dodatne informacije u najnovijem sigurnosno-tehničkom listu za SAD (engl. Safety Data Sheet; SDS) i sigurnosno-tehničkom listu za EU.

Prije pomjeranja oprema uvijek je isključite i iskopčajte iz napona izvora napajanja.

Servisiranje i popravke treba obavljati kvalificirani serviser.

Opremu držite na rasponu temperature od -25 °C do 60 °C (s pakiranjem) i relativnoj vlažnosti od <80 %.

Stavljanje izvan pogona mora obaviti isključivo kvalificirani trgovac pomoću certificirane opreme. Moraju se slijediti svi važeći propisi.

Obavljanje postupaka ugradnje, korištenja ili održavanja koji nisu opisani u priručniku može dovesti do opasne situacije i poništiti će jamstvo proizvođača.

Nikad nemojte primjenjivati linijski napon na komunikacijske priključke na rashladnom uređaju.

Ako ne napunite rashladni uređaj i crijeva za radnu tekućinu do kraja, može doći do oštećenje pumpe rashladnog uređaja. Nemojte prepunjavati jer se tekućina širi prilikom zagrijavanja.

Na rashladnom uređaju ThermoFlex, prije zamjene kućišta rezervoara potrebno je osigurati da čep indikatora razine u rezervoaru bude čvrsto na mjestu.

Rashladni uređaj ThermoFlex900-5000 nemojte koristiti ako difuzor rezervoara nije ugrađen.

Ako je rashladni uređaj opremljen volumetrijskom pumpom (P1 ili P2), pazite da vodovodna crijeva i spojnice mogu podnijeti najmanje 185 psi.

Nemojte koristiti antifriz za automobile. Komercijalni antifriz sadrži silikate koji oštećuju brtve pumpe.

Kako bi se spriječilo smrzavanje pločastog izmjenjivača, rashladni uređaji ThermoFlex7500-24000 zahtijevaju upotrebu smjese od 50/50 etilen glikola/vode ili 50/50 propilen glikola/vode na radnoj temperaturi ispod 10 °C.

Prilikom upotrebe smjese radne tekućine od etilen glikola/vode ili propilen glikola/vode, redovito provjeravajte koncentraciju tekućine i pH vrijednost. Promjene u koncentraciji i pH vrijednosti mogu utjecati na performanse sustava.

Nemojte koristiti uložak filtra za deioniziranje s inhibiranim etilen glikolom ili inhibiranim propilen glikolom. Filter za deioniziranje uklanja inhibitore iz otopine, što tekućinu čini nedjelotvornom u zaštiti od korozije. Pored toga, inhibitori povećavaju provodljivost tekućine. Softver polarnog rashladnog uređaja mora se prilagoditi kako bi odgovarao korištenoj radnoj tekućini.

Biocidi su nagrizajući i mogu uzrokovati nepopravljiva oštećenja očiju i opekline. Štetni su ako se udahnu, progutaju ili upiju kroz kožu. Pogledajte najnoviji sigurnosno-tehnički list proizvođača.

Kako bi se spriječilo oštećenje pločastog izmjenjivača rashladnog uređaja, centrifugalne pumpe zahtijevaju minimalni protok od 4,0 g/min (15,1 l/min).

Ako se filter kondenzatora ne čisti/mjenja, dolazi do gubitka kapaciteta hlađenja i prijevremenog kvara sustava hlađenja. Za temeljito čišćenje uklonite sklop prednje rešetke.

Na zrakom hlađenim rashladnim uređajima okvir i vertikalni stabilizatori kondenzatora nalaze se iza sklopa prednje rešetke i veoma su oštri. Izuzev zračno hlađenog sklopa rešetke nikad nemojte koristiti rashladni uređaj kad je bilo koja ploča skinuta.

Vodom hlađeni rashladni uređaji ThermoFlex900-5000 imaju ventilator s oštirim lopaticama te stoga rashladni uređaj morate isključiti prije skidanja prednje rešetke.

### **Predviđena namjena, cirkulirajući rashladni uređaji:**

Cirkulirajući rashladni uređaji tvrtke Thermo Scientific predviđeni su za pružanje kontinuirane isporuke tekućine uz konstantnu temperaturu i protok. Rashladni uređaj se sastoji od zrakov hlađenog ili vodom hlađenog rashladnog sustava, izmjenjivača topline, cirkulirajuće pumpe, rezervoara radne tekućine i kontrolera mikroprocesora.

Rashladni uređaji su predviđeni za kontinuirani rad i primjenu u zatvorenim prostorima u skladu sa svim postupcima i zahtjevima navedenim u njihovim priručnicima.

### **Ugradnja, cirkulirajući rashladni uređaji:**

Postavite rashladni uređaj tako da je blizu i ima jednostavan pristup svom uređaju za iskopčavanje.

Rashladni uređaj je predviđen za upotrebu na namjenskoj utičnici.

Obavezno skinite sve ambalažne čepove vodovodnih crijeva prije ugradnje.

Priključci rashladne tekućine nalaze se sa stražnje strane rashladnog uređaja i označeni su sa  (PROCESS INLET) (radni ulazni otvor) i  (PROCESS OUTLET) (radni izlazni otvor). Povežite  na ulazni otvor za tekućinu na vašem uređaju. Povežite  na izlazni otvor za tekućinu na vašem uređaju.

Kod vodom hlađenih rashladnih uređaja povežite  (FACILITY INLET) (ulazni otvor za postrojenje) na vodovod postrojenja. Povežite  (FACILITY OUTLET) (izlazni otvor za postrojenje) na povratni vod ili odvod postrojenja.

Prije pokretanja rashladnog uređaja dvaput provjerite sve relevantne komunikacijske, električne i vodovodne priključke.

**HU**

## Alapvető biztonsági utasítások Recirkulációs hűtők

Ha valamelyik utasítást nem érti, lapozza fel a kézikönyvet, vagy forduljon hozzánk, mielőtt folytatná a munkát.

### **Biztonság – összes termék:**

**DANGER** Közvetlen veszélyhelyzetet jelez, amely halált vagy súlyos sérülést okoz, ha meg nem előzik.

**WARNING** Potenciálisan veszélyes helyzetet jelez, amely halált vagy súlyos sérülést okoz, ha meg nem előzik.

**CAUTION** Potenciálisan veszélyes helyzetet jelez, amely enyhe, vagy közepes sérülést okozhat, ha meg nem előzik. A nem biztonságos eljárásokra is ez a jelzés figyelmeztet.

 Veszélyes mértékű, nem szigetelt feszültség jelenlétére figyelmezteti a felhasználót a hűtő házában. A feszültség nagysága elég jelentős ahhoz, hogy áramütés veszélyét jelentse.

 Forró felületek okozta veszélyre figyelmeztet.

 Azt jelzi, hogy el kell olvasni a használati utasítást.

Ne használja a berendezést steril vagy beteghez csatlakoztatott eszközként. Továbbá a berendezés nem használható a National Electrical Code szabvány által definiált I., II. vagy III. osztályú veszélyes helyen.

A berendezés csak beltérben használható. Ne helyezze a hűtőt olyan helyre, amelyet erős hő, nedvesség, elégtelen szellőzés vagy korrozív anyagok jelenléte jellemez. Az üzemi paraméterek megtalálhatók a kézikönyvben.

Csatlakoztassa a berendezést egy megfelelően földelt csatlakozójelzőhöz.

Az alkalmazott hűtőközegek nehezebbek a levegőnél, ezért szivárgás esetén kiszorítják az oxigént, ami eszméletvesztést okoz. A szivárgó hűtőközeg a bőrrel érintkezve fagyást okoz. A hűtőközeg típusa fel van tüntetve a berendezés adattábláján, további információkat pedig a gyártó legfrissebb amerikai biztonsági adattábláján (SDS, korábbi nevén MSDS) vagy európai biztonsági adattábláján találhat.

A berendezés mozgathatókor legyen óvatos. A zökkenések vagy leejtés kárt tehet a berendezés komponenseiben. Mozgatás előtt mindig kapcsolja ki és válassza le az áramforrástól a berendezést.

Ne üzemeltesse a berendezést, ha az sérült vagy szivárog.

Ne használjon gyúlékony vagy korrozív folyadékokat. Csak a kézikönyvben szereplő, jóváhagyott folyadékokat használjon. Mielőtt bármilyen folyadékokat használna, illetve olyan karbantartást végezne, amely várhatóan folyadékkal való érintkezéssel jár, ismerkedjen meg a gyártó legfrissebb amerikai biztonsági adattábláján (SDS) vagy európai biztonsági adattábláján szereplő információkkal.

Mozgatás előtt mindig kapcsolja ki és válassza le az áramforrástól a berendezést.

A szervizelés és a javítást bízza képzett szakemberre.

A berendezést -25 és 60 °C közötti hőmérséklet (csomagolással) és 80% alatti relatív páratartalom mellett kell tárolni.

Az üzemén kívül helyezést csak szakkereskedő hajthatja végre, minősített berendezés használatával. Minden érvényben lévő előírást be kell tartani.

A telepítési, üzemeltetési, illetve karbantartási eljárásoknak a kézikönyvben foglalttól eltérő végrehajtása veszélyes helyzetet teremthet, és érvénytelenné teszi a gyártó garanciáját.

Soha ne vezessen hálózati feszültséget a hűtő kommunikációs csatlakozóba.

Ha a hűtő és az üzemi folyadék-vezetékek nincsenek teljesen feltöltve, akkor kár keletkezhet a berendezés szivattyújában. Tartózkodjon a túltöltéstől, melegeitör a folyadékok tágulásnak.

ThermoFlex esetében a tartály házának cseréje előtt gondoskodjon arról, hogy a tartály vizsgálócsövének golyós elzárója stabilan a helyén legyen.

ThermoFlex900–5000 esetében ne üzemeltesse a hűtőt, amíg nincs felszerelve a tartály folyadékporlasztója.

Ha a hűtő térfogat-kiszorításos szivattyúval (P1 vagy P2) rendelkezik, akkor a rendszer csővezetékeinek és -szerelvényeinek el kell viselnie legalább 12,8 bar (185 psi) nyomást.

Ne használjon autópipari fagyállót. A kereskedelemben kapható fagyállókban található szilikátok kárt tesznek a szivattyú tömítéseiben.

A lemezes hőcserélő fagyásának/jegesedésének megelőzése érdekében a ThermoFlex7500–24000 hűtők 50/50 EG/víz, illetve 10 °C üzemi hőmérséklet alatt 50/50 PG/víz használatát igénylik.

EG/víz vagy PG/víz üzemi folyadék-keverék használata esetén rendszeres időközönként ellenőrizni kell a folyadék koncentrációját és pH-értékét. A koncentráció és a pH-érték változása befolyásolhatja a rendszer teljesítményét. Inhibitoros EG vagy inhibitoros PG esetén ne használjon deionizáló (DI) szűrőbetétet.

A DI-szűrő eltávolítja az oldatból az inhibitorokat, így a folyadék hatástalan lesz a korrózióvédelem szempontjából. Az inhibitorok emellett növelik a folyadék vezetőképességét.

A biocidok és a korrozív anyagok visszafordíthatatlan szemkárosodást és a bőr égési sérülését okozhatják. Belélegezve, lenyelve és a bőrön át felszívódva is ártalmasak. További információkat a gyártó legfrissebb biztonsági adattábla tartalmaz.

A hűtő lemezes hőcserélője sérülésének megelőzése érdekében a centrifugálszivattyúknak 15,1 l/perc (4,0 gallon/perc) minimális térfogatárammal kell működniük.

A kondenzátorszűrő tisztításának/cseréjének elmulasztása a hűtési kapacitás csökkenéséhez és a hűtőrendszer idő előtti meghibásodásához vezet.

A gondos tisztítás érdekében távolítsa el az elülső rácsszerelvényt. Léghűtőeszes hűtők esetében az elülső rácsszerelvény mögött található kondenzátor váza és bordázata nagyon éles.

A léghűtőeszes rácsszerelvénytől eltekintve soha ne üzemeltesse a hűtőt eltávolított panellel.

A vízihűtőeszes ThermoFlex900–5000 hűtőkben éles lapátokkal rendelkező ventilátor található. Az elülső rács eltávolítása előtt győződjön meg arról, hogy a hűtő ki van kapcsolva.

### **Rendeltetészerű használat, recirkulációs hűtők:**

A Thermo Scientific recirkulációs hűtői folyamatos, állandó hőmérsékletű és térfogatáramú folyadékellátás biztosítására szolgálnak. A hűtőt egy lég- vagy vízihűtőeszes hűtőrendszer, egy hőcserélő, egy újrakeringető szivattyú, egy üzemi folyadék-tartály és egy mikroprocesszoros vezérlő alkotja.

A hűtők folyamatos beltéri üzemeltetésre szolgálnak a kézikönyvükben foglalt valamennyi eljárás és követelmény szem előtt tartásával.

### **Telepítés, recirkulációs hűtők:**

Úgy helyezze el a hűtőt, hogy a megszakítója a közelében, könnyen hozzáférhető helyen legyen.

A berendezést kifejezetten erre a célra szolgáló aljzathoz kell csatlakoztatni.

Telepítés előtt távolítsa el valamennyi csővezeték szállítódugóit.

Az üzemi folyadék csatlakozásai a hűtő hátulján található  (PROCESS OUTLET – üzemi kimenet) és  (PROCESS INLET – üzemi bemenet) címkével. A  csatlakozóhoz csatlakoztassa a rendszer folyadékmenetét, a  csatlakozóhoz pedig a folyadékmenetét.

Vízihűtőeszes hűtő esetén csatlakoztassa a létesítmény vizellátását a  (FACILITY INLET – létesítménybemenet) csatlakozáshoz. A  (FACILITY OUTLET – létesítménykimenet)

csatlakozást csatlakoztassa a létesítmény víz visszavezető rendszeréhez vagy a lefolyóhoz.

A hűtő elindítása előtt újból ellenőrizze az összes szükséges kommunikációs, elektromos és csővezeték-csatlakozást.



## Pagrindinės saugos instrukcijos Recirkuliuojantys aušintuvai

Jei kurios nors iš šių instrukcijų yra nesuprantamos, prieš tęsdami skaitykite vadovą arba kreipkitės į mus.

### Sauga, visi gaminiai:

**DANGER** nurodo neišvengiamai pavojingą situaciją, kurios neišvengus, galima mirties arba rimto sužalojimo baigtis.

**WARNING** nurodo galimai pavojingą situaciją, kurios neišvengus, galima mirties arba rimto sužalojimo baigtis.

**CAUTION** nurodo galimai pavojingą situaciją, kurios neišvengus, kyla neįrimto arba vidutinės sužalojimo tikimybės. Taip pat galima pranešti, kai yra naudojama nesaugiai.

 skirta pranešti naudotojui, kai prie aušintuvo yra neizoliuota „pavojinga įtampa“. Įtampos dydis yra gana svarbus ir gali sukelti elektros šoko pavojų.

 nurodo esamus karštus paviršius.

 nurodo skaityti vadovą.

Nenaudokite įrangos kaip steriliaus ar prie paciento prijungto prietaiso. Be to, įranga nėra skirtas naudoti I, II ir III klasės pavojingose vietose, kaip nurodyta Nacionaliniame elektros kodekse.

Įranga yra sukurta tik naudoti viduje. Niekada nedėkite jo vietoje, kur yra per didelis karštis, drėgmė, netinkamas vėdinimas arba korozinių medžiagų. Darbinių parametru iškokite vadove.

Prijunkite įrangą prie tinkamai žeminto išvado.

Naudojami aušalai yra sunkesni nei oras ir, esant nutekėjimui, jie išstums deguonį, dėl ko galima prarasti sąmonę. Prisilietus prie ištėkėjusių aušalų, galima nudegti odą. Naudojamo aušalo tipo ir gamintojo naujausios JAV saugumo duomenų išklotinės (SDS), anksčiau žinomos kaip MSDS bei ES saugumo duomenų išklotinės papildomos informacijos iškokite cirkulatoriaus techninių duomenų lentelės.

Įrangą perkeltite atsargiai. Staigus krestelėjimai arba kritimai gali pažeisti jos komponentus. Prieš perkeldami visuomet išjunkite įrangą ir atjunkite juo maitinimo įtampos.

Niekada nenaudokite pažeistos ar tekancios įrangos.

Niekada nenaudokite degių ar korozinių skysčių. Naudokite tik vadove išvardintus patvirtintus skysčius.

Prieš pradėdami naudoti bet kokius skysčius ar atlikdami priežiūrą, kurios metu gali pasitaikyti kontaktų su skysčiu, papildomos informacijos ieškokite gamintojo naujausioje JAV saugumo informacijos išklotinėje (SDS) ir ES saugumo informacijos išklotinėje.

Prieš perkeldami visuomet išjunkite įrangą ir atjunkite juo maitinimo įtampos.

Aptarnavimo ir remonto kreipkitės į kvalifikuotą techniką.

Laikykite įrangą temperatūros intervale nuo -25 °C iki 60 °C (su įpakavimu) ir <80 % santykinėje drėgmėje.

Eksploatacijos nutraukimą turi atlikti tik kvalifikuotas pardavėjas, naudojantis sertifikuoatą įrangą. Reikia laikytis visų galiojančių nuostatų.

Kitokių įrengimo, naudojimo ir priežiūros procedūrų nei nurodyta vadove gali sukelti pavojingą situaciją ir aniliuos gamintojo garantiją.

Niekada nejunkite linijos įtampos prie bet kurių komunikacinių jungčių aušintuve.

Ne visiškai užpildžius aušintuvą darbinių skysčių linijos gali sugadinti aušintuvo siurbį. Venkite perpildymo, išilę skysčiai plečiasi.

„ThermoFlex“ sistemoje prieš pakeisdami rezervuaro korpusą, įsitikinkite, kad rezervuaro matomumo vamzdelio rutulinis kamštelis yra saugiai įstatytas.

„ThermoFlex900-5000“ sistemoje nenaudokite aušintuvo jei nėra įrengtas rezervuaro skysčio skirstytuvas.

Jei jūsų aušintuve yra stūmoklims siurblys (P1 arba P2), užtikrinkite, kad jūsų pritaikytas kanalizacijos vamzdynas ir jungtys yra nominuoti atlaikyti mažiausiai 185 psi („ThermoChill“ – 115 psi, „Merlin“ – 110 psi).

Nenaudokite automobilinio antifrizo. Komerciniuose antifrizuose yra silikatų, kurie pažeidžia siurblio sandarumą.

Kad plokščių keitiklis neužšaltų / nepasidengtų ledu, „ThermoFlex7500-24000“ aušintuvams reikia naudoti 50/50 EG / vanduo arba 50/50 PG / vanduo 10°C žemiau darbinės temperatūros.

Naudodami darbinio skysčio EG / vandens arba PG / vandens mišinį, reguliariai tikrinkite skysčio koncentraciją ir pH. Koncentracijos ir pH pakitimai gali turėti įtakos sistemos veikimui. Nenaudokite Dejonizacijos (DJ) filtro dėžutės su EG inhibitoriumi arba PG inhibitoriumi.

DJ filtras pašalins inhibitorius iš mišinio ir padarys skysčio apsaugą nuo korozijos neefektyvia. Inhibitoriai taip pat didina specifinį skysčio laidumą.

Biocidai sukelia koroziją ir gali nepagydomai pažeisti akis ar nudeginti odą. Jie yra kenksmingi įkvėpus, nurijus ar įsisavinus per odą. Naujausios SDS kreipkitės į gamintoją.

Kad aušintuvo plokščių keitiklis nebūtų sugadintas, išcentriniams siurbliams reikia 4,0 gpm (15,1 lpm) mažiausio tekėjimo srauto.

Neišvalius / nepakeitus kondensatoriaus filtro gali sumažėti aušinimo apimtys ir tai gali baigtis pirmalaikiu vėsinimo sistemos gedimu. Visiškai išvalymui išimkite priekinių grotelių sąranką.



Oru vėsinamuose aušintuvuose kondensatoriaus rėmas ir mentės, esantys už priekinių grotelių sąrankos, yra labai aštrūs.

Kitokiose nei oru vėsinamų aušintuvų grotelių sąrankose, niekada nenaudokite aušintuvo su nuimtu skydeliu.

„ThermoFlex900-5000“ vandeniui vėsinami aušintuvai turi ventilatorius su aštriomis mentėmis, prieš nuimdami grotėles, įsitinkite, kad aušintuvas yra išjungtas.

### **Numatytas naudojimas, Recirkuliuojantys aušintuvai:**

„Thermo Scientific“ recirkuliuojantys aušintuvai yra sukurti tiekti nuolatinį kiekį tos pačios temperatūros ir tekėjimo srauto skysčio. Aušintuvą sudaro oru arba vandeniui vėsinama šaldymo sistema, šilumokaitis, recirkuliacinio siurblys, darbinio skysčio rezervuaras ir mikroprocesorinis valdiklis.



Aušintuvai yra sukurti nepertraukiamam veikimui ir tik naudojimui viduje pagal visas procedūras ir reikalavimus, išdėstytus šiame vadove.

### **Įrengimas, Recirkuliuojantys aušintuvai:**

Pastatykite aušintuvą, kad jis būtų arti ir lengvai pasiekiamo atjungimo prietaiso.

Aušintuvas yra skirtas naudoti su atskiru išvadu.

Prieš įrengimą, užtikrinkite, kad visi kanalizacijos vamzdyno transportavimo kamščiai yra išimti.

Darbinio skysčio jungtis yra aušintuvo užpakalyje ir yra pažymėtos  (PROCESS INLET) (DARBINIS ĮVADAS). Prijunkite  prie skysčio įvado jūsų pritaikyme. Prijunkite  prie skysčio išvado jūsų pritaikyme.

Vandeniui vėsinamiems aušintuvams prijunkite  (FACILITY INLET) (KOMPLEKSO ĮVADAS) prie jūsų komplekso vandens tiekimo. Prijunkite  (FACILITY OUTLET) (KOMPLEKSO IŠVADAS) prie jūsų komplekso vandens grąžinimo arba drenažo.

Prieš paleisdami aušintuvą dar kartą patikrinkite visas galimas komunikacines, elektros ir kanalizacijos jungtis.



## Būtiskas drošības instrukcijas Recirkulācijas dzesētāji

Ja kāda no šīm instrukcijām nav saprotama, pirms turpināt darbu, skatiet rokasgrāmatu vai sazinieties ar mums.

### Drošības apzīmējumi (attiecas uz visiem izstrādājumiem)



Norāda uz nopietnu apdraudējumu, kas var izraisīt nāvi vai nopietnas traumas, ja netiek novērsta.



Norāda uz potenciāli bīstamu situāciju, kas var izraisīt nāvi vai nopietnas traumas, ja netiek novērsta.



Norāda uz potenciāli bīstamu situāciju, kas var izraisīt vieglas vai mērenas traumas, ja netiek novērsta. Šis apzīmējums arī tiek izmantots, lai brīdinātu par nedrošu rīcību.



Brīdina lietotāju par neizolēta bīstama sprieguma klātbūtni dzesētāja korpusā. Spriegums ir pietiekami augsts, lai radītu elektrotrieciena gūšanas risku.



Norāda uz karstu virsmu klātbūtni.



Norādījums lasīt rokasgrāmatu.

Neizmantojiet aprīkojumu kā sterilu vai ar pacientu saistītu ierīci. Turklāt aprīkojums nav paredzēts lietošanai I, II vai III klases bīstamās zonās atbilstoši ASV Nacionālās elektrotehnikas standartu sistēmas prasībām.

Aprīkojums ir paredzēts lietošanai tikai slēgtās telpās. To nekādā gadījumā nedrīkst novietot vietā, kur pastāv pārmērīga karstuma, mituma vai korozīvu vielu klātbūtne, vai arī nav piemērota ventilācija.

Eksploataācijas parametrus skatiet rokasgrāmatā.

Pieslēdziet aprīkojumu atbilstoši saņemtai kontaktligzdai.

Izmantoie aukstumagēnti ir smēgāki par gaisu un noplūdes gadījumā izspiedīs skābekli, izraisot samanažas zudumu. Nonākot saskarē ar noplūdušu aukstumagēntu, rodas ādas apdegumi. Izmantojamā aukstumagēnta veidu skatiet uz cirkulatora nominālvērtību plāksnītes, savukārt papildinformāciju skatiet jaunākajā ražotāja nodrošinātajā ASV drošības datu lapā (SDS) (kādreizējā MSDS), kā arī ES drošības datu lapā.

Pārvietojot aprīkojumu, ievērojiet piesardzību. Pēkšņi satricinājumi vai krišana var sabojāt tā sastāvdaļas.

Pirms aprīkojuma pārvietošanas vienmēr to izslēdziet un atvienojiet no elektroapgādes tīkla.

Nekādā gadījumā nedarbiniēt aprīkojumu, ja tas ir bojāts vai tam ir sāpce.

Nekādā gadījumā nelietojiet viegli uzliesmojošus vai korozīvus šķīdumus. Izmantojiet tikai apspīrinātos šķīdumus, kas norādīti rokasgrāmatā. Pirms jebkāda šķīduma lietošanas vai tādu apkopes darbu veikšanas, kuru laikā iespējams nonākt saskarē ar šķīdumu, skatiet papildinformāciju jaunākajās ražotāja nodrošinātajās ASV drošības datu lapās (SDS) un ES drošības datu lapās.

Pirms aprīkojuma pārvietošanas vienmēr to izslēdziet un atvienojiet no elektroapgādes tīkla.

Apkalpošanu un remontu drīkst veikt tikai atbilstoši kvalificēti tehniskie speciālisti.

Aprīkojums jāuzglabā temperatūras diapazonā no -25 °C līdz 60 °C (ar iepakojumu) un pie -80% relatīvā mitruma.

Izņemšanu no eksploataācijas drīkst veikt tikai attiecīgi kvalificēts izplatītājs, izmantojot sertificētu aprīkojumu. Ir jāievēro visu piemērojamo likumdošanas aktu prasības.

Ja tiek veikta uzstādīšanas, eksploataācijas vai apkopes procedūras, kas atšķiras no šajā rokasgrāmatā aprakstītajām, var rasties bīstamas situācijas, un tiek anulēta ražotāja garantija.

Nekādā gadījumā nepievienojiet līnijas spriegumu jebkādiem dzesētāja sakaru savienojumiem.

Ja dzesētājs un tehniskā šķīduma līnijas nav pilnībā uzplūdītas, var rasties dzesētāja sūkņa bojājumi. Ir jāizvairās no pārmērīgas uzplūdes, jo šķīdumi karstuma ietekmē izplešas.

Pirms ThermoFlex rezervuāra korpusa nomainīšanas nodrošini, lai rezervuāra līmeņa indikatora lodītes aizturis būtu droši nostiprināts vietā.

Ierīcēm ThermoFlex900-5000 nedarbiniēt dzesētāju, kamēr nav uzstādīts rezervuāra šķīduma difuzors.

Ja dzesētājs ir aprīkots ar vizuālsūkni (P1 vai P2), nodrošini, lai ierīces caurules un savienojumi varētu izturēt vismaz 185 psi.

Nedrīkst lietot automobiļiem paredzētu antifīzū. Komerciāli pieejamais antifīzrs satur silīkāts, kas bojā sūkņa blīvījumus.

Lai novērstu siltummaiņa plāksņu sasaīšanu/apledošanu, ThermoFlex7500-24000 dzesētājiem nepieciešams lietot 50/50 EG/ūdens vai 50/50 PG/ūdens darba temperatūrai zem 10 °C.

Ja tehniskais šķīdums ir EG/ūdens vai PG/ūdens maisījums, regulāri pārbaudiet šķīduma koncentrāciju un pH līmeni. Koncentrācijas un pH līmeņa izmaiņas var ietekmēt sistēmas veiktspēju.

Nelietojiet dejonizācijas (DI) filtra kasetni ar inhibētu EG vai inhibētu PG. DI filtrs atdalīs inhibitorus no šķīduma, padarot šķīdumu neefektīvu aizsardzībai pret koroziju. Inhibitori arī palielina šķīduma vadītspēju.

Biocīdi ir korozīvi un var izraisīt neatgriezeniskus acu bojājumus un ādas apdegumus. To iedarbība ir kaitīga, ja tie tiek ieelpoti, norīti vai absorbēti caur ādu. Skatiet jaunākās ražotāja nodrošinātās SDS.

Lai novērstu dzesētāja siltummaiņa plāksņu bojājumu rašanos, centrifūgas sūkņiem nepieciešamais minimālais caurplūdums ir 4,0 gpm (15,1 lpm).

Ja kondensatora filtrs netiek tīrīts/nomainīts, tiek izraisīts dzesēšanas kapacitātes zudums un priekšlaicīga dzesēšanas sistēmas atteice. Lai veiktu rūpīgu tīrīšanu, noņemiet priekšējo režģi.

Dzesētājiem ar gaisa dzesēšanu kondensatora rāmis un ribas, kas atrodas aiz priekšējā režģa, ir ļoti asas. Izņemot ierīces ar gaisa dzesēšanas režģi, nekādā gadījumā nedarbiniet dzesētāju, ja ir noņemts kāds panelis.

ThermoFlex900-5000 dzesētājiem ar ūdens dzesēšanu ir ventilators ar asām lāpstņām, tādēļ pirms priekšējā režģa noņemšanas nodrošiniet, lai dzesētājs būtu izslēgts.

## Recirkulācijas dzesētāju paredzētais lietojums

Thermo Scientific recirkulācijas dzesētāji ir paredzēti, lai nodrošinātu pastāvīgu šķidrums padevi ar konstantu temperatūru un plūsmas ātrumu. Dzesētājs sastāv no dzesēšanas sistēmas ar gaisu vai ūdens dzesēšanu, siltummaiņa, recirkulācijas sūkņa, tehniskā šķidrums rezervuāra un mikroprocesoru kontrolera.

Dzesētāji ir paredzēti pastāvīgai darbināšanai slēgtās telpās telpās atbilstoši visām procedūrām un prasībām, kas norādītas šajā rokasgrāmatā.

## Recirkulācijas dzesētāju uzstādīšana

Novietojiet dzesētāju, lai tas atastos atvienošanas ierīces tuvumā un tā būtu viegli pieejama.

Dzesētājs ir paredzēts pievienošanai pie atsevišķas kontaktlīdzes.

Nodrošiniet, lai pirms uzstādīšanas būtu noņemti visi transportēšanai paredzētie cauruļvadu aizgriežņi.

Tehniskā šķidrums savienojumi atrodas dzesētāja aizmugurē un ir apzīmēti kā  (PROCESS OUTLET) (DARBA ŠĶIDRUMA IZPLŪDE) un  (PROCESS INLET) (DARBA ŠĶIDRUMA IEPLŪDE). Pievienojiet  ierīces šķidrums ieplūdes vietai. Pievienojiet  ierīces šķidrums izplūdes vietai.

Dzesētājiem ar ūdens dzesēšanu pievienojiet  (FACILITY INLET) (ŪDENS PADEVE) izmantojamā ūdens padevei. Dzesētājiem ar ūdens dzesēšanu pievienojiet  (FACILITY OUTLET) (ŪDENS IZPLŪDE) izmantojamā ūdens atplūdei vai izvadei.

Pirms dzesētāja iedarbināšanas vēlreiz pārbaudiet visus sakaru, elektriskos un cauruļvadu savienojumus.

# Istruzzjonijiet Essenzjali tas-Sigurtà Recirculating Chillers

Jekk xi waħda minn dawn l-istruzzjonijiet ma tinfi hemx, irreferi għall-manwal jew ikkuntattja qabel ma tipproċedi.

**Sigurtà: il-prodotti kollha:**

**DANGER** jindika sitwazzjoni perikoluża b'mod imminenti, li jekk ma tiġix evitata, se tirriżulta f'mewt jew f'korrimment serju.

**WARNING** jindika sitwazzjoni potenzjalment perikoluża, li jekk ma tiġix evitata, tista' tirriżulta f'mewt jew f'korrimment serju.

**CAUTION** jindika sitwazzjoni potenzjalment perikoluża, li jekk ma tiġix evitata, tista' tirriżulta f'korrimment żgħir jew moderat. Jista' jintuża wkoll biex iwissi kontra prattiċi li mhumiex siguri.

 intenzjonat biex iwissi lill-utent dwar il-preżenza ta' "vultaġġ perikoluż" mhux insulat fl-enclosure ta' chiller. Il-qawwa tal-vultaġġ hi sinifikanti biżżejjed biex tikkostitwixxi riskju ta' xokk elettriku.

 jindika l-preżenza ta' wċuħ jaħarqu.

 jindika biex dak li jkun jaqra l-manwal.

Tużax it-tagħmir bħala tagħmir sterili jew tagħmir li jiġi kkonnettjat mal-pazjent. Barra minn hekk, it-tagħmir mhuwieq ma'sub għall-użu f'Postijiet Perikolużi ta' Klassi I, li jwarrja lill-kif definit min-National Electrical Code.

Dan it-tagħmir hu ma'sub biex jintuża fuq ġewwa biss. Qatt ipoġġih f'post fejn ikun hemm shana eċċessiva, umdià, ventilazzjoni inadegwata, jew materjali korrużivi. Irreferi għall-manwal għall-parametri tal-operat. Ikkonnettja t-tagħmir ma' outlet li jkun erjat kif support.

Ir-refrigerants użati huma itqal mill-arja u, jekk ikun hemm tniixxja, se jissostitwixxu l-ossigenu u jikkawżaw li wieħed jimitief minn sensih. Kuntatt ma' refrigerant li jkun qed inixxi se jikkawża ħruq tal-ġilda. Irreferi għas-circulator nameplate għat-tip ta' refrigerant użat u mbagħad għal US Safety Data Sheet (SDS) l-aktar riċenti tal-manifattur, li qabel kienet magħnufa bħala MSDS, u l-EU Safety Data Sheet għal informazzjoni addizzjonali.

Ċaqlaq it-tagħmir b'attenzjoni. Skossi għall-għarrieda jew li twaqqa' t-tagħmir, jistgħu jagħmlu ħsara lill-komponenti tiegħu. Dejjem iffi t-tagħmir u skonnettjah minn mal-provvista tad-dawl tiegħu qabel iċċaqliqu. Qatt m'għandek tħaddem tagħmir bil-ħsara jew tagħmir li jkun qed inixxi.

Qatt m'għandek tużax fluwidu li jstgħu jehdu n-nar jew li huma korrużivi. Uża biss il-fluwidu approvati li huma elenkati fil-manwal. Qabel tużax kwalunkwe fluwidu jew twestaq manutenzjoni fejn x'aktarx se jkun hemm kuntatt mal-fluwidu, irreferi għal US Safety Data Sheet (SDS) l-aktar riċenti tal-manifattur, u l-EU Safety Data Sheet għal informazzjoni addizzjonali.

Dejjem iffi t-tagħmir u skonnettjah minn mal-provvista tad-dawl tiegħu qabel iċċaqliqu.

Irreferi s-service u t-tiswijiet lill-technician ikkwalifikat.

Ahzen it-tagħmir f'medda ta' temperatura ta' -25°C sa 60°C (bl-ippakkjar), u umdià relattiva ta' <80%.

Id-dekmissionar irid isir biss minn aġent ikkwalifikat bl-użu ta' tagħmir iċċertifikat. Ir-regolamenti prevalenti kollha jridu jiġu segwiti.

Il-prestazzjoni tal-proċeduri tal-installazzjoni, operat, jew manutenzjoni, h'ief dawk deskritti fil-manwal, jistgħu jirriżultaw f'sitwazzjoni perikoluża, u dan se jħassar il-garanzija tal-manifattur.

Qatt m'għandek tapplika line voltage li xi waħda mill-konnessjonijiet tal-komunikazzjoni fuq iċ-chiller.

Li ma timliex iċ-chiller u l-process fluid lines kompletament, dan jista' jagħmel ħsara lill-pompa ta' chiller. Evita li timla żżejjed; il-fluwidu jespandu meta jissatnu.

Fuq ThermoFlex, qabel tibdel ir-reservoir housing, kun żgur li r-reservoir sight tube ball stopper ikun f'postu b'mod sigur.

Fuq ThermoFlex900-5000, tħaddimx iċ-chiller h'ief jekk ir-reservoir fluid diffuser ikun installat.

Jekk iċ-chiller tiegħek ikun m'għammar b'positive displacement pump (P1 jew P2), accertata ruħek li l-application plumbing lines u l-fittings ikunu rated biex jiflihu minimu ta' 185 psi.

Tużax antifreeze ta' karozzi. Antifreeze kummerċjali fih silicates li jagħmlu ħsara lis-sigilli tal-pompa.

Biex tipprevjeni l-iffriżar/glazing tal-plate exchanger, ThermoFlex7500-24000 chillers jeħtieġu l-użu ta' 50/50 EG/lima jew 50/50 PG/lima taħt it-temperatura tal-proċess ta' 10°C.

Meta tużax taħlita ta' fluwidu tal-process ta' EG/lima jew PG/lima, iċċekkja l-koncentrazzjoni tal-fluwidu u l-pH fuq bażi regolari. Bidliet fil-koncentrazzjoni u l-pH jista' jkollhom impatt fuq il-prestazzjoni tas-sistema. Tużax Deionization (DI) filter cartridge b'inhibited EG jew inhibited PG. DI filter se jneħthi l-inibituri mis-soluzzjoni u dan jagħmel il-fluwidu mhux effettiv kontra l-protezzjoni mill-korrużjoni.

Il-bjoċidi huma korrużivi u jstgħu jikkawżaw ħsara irriversibbli fl-għajnejn u ħruq tal-ġilda. Dawn huma perikolużi jekk jingibdu man-nifs, jinbelgħu jew jiġu assorbiti mill-ġilda. Irreferi għall-SDS l-aktar riċenti tal-manifattur.

Biex tipprevjeni ħsara liċ-chiller's plate exchanger, centrifugal pumps jeħtieġu rata minima ta' cirkolazzjoni ta' 4.0 gpm (15.1 lpm).

Li ma tnaaddax/tbidli l-condenser filter, se jikkawża telf tal-kapaċità ta' ikessiħ u jwassal għal ħsara prematura tas-sistema ta' ikessiħ. Biex tnaaddax bir-reqqa, neħthi l-front grill assembly.

Fuq air-cooled chillers, il-condenser framing u fins li jinsabu wara l-front grill assembly, jaqtgħu ħafna.

Fliet għall-air-cooled grill assembly, qatt m'għandek tħaddem iċ-chiller bi kwalunkwe panel imnefhi.

ThermoFlex900-5000 water-cooled chillers għandhom fan bi blades jaqtgħu; aċċerta ruġek li iċ-chiller ikun mifti qabel ma' tnefhi l-grill ta' quddiem.

### **Użu Intenzjonat, Recirculating Chillers:**

Thermo Scientific recirculating chillers huma maħsuba biex jipprovdu provvista kontinwa ta' fluwidu b'rata kostanti ta' temperatura u fluss. Iċ-chiller jikkonsisti minn sistema ta' refrigerazzjoni mkessha bl-arja jew mkessha bi-ljima, recirculating pump, process fluid reservoir u microprocessor controller.





Iċ-chillers huma maħsuba biex jaħdmu l-hin kollu u biex jintużaw fuq gewwa, skont il-proċeduri u r-rekwiżiti kollha deskritti fil-manwali tagħhom.

### **Installazzjoni, Recirculating Chillers:**

Pogġi iċ-chiller b'tali mod li jkun qrib, u jkun hemm aċċess faċli, għat-tagħmir ta' skonetttjar tiegħu.

Iċ-chiller hu maħsub għall-użu fuq dedicated outlet.

Kun żgur li l-plumbing line shipping plugs jimejnew kollha qabel l-installazzjoni.

Il-konnessjonijiet tal-process fluid jinsabu fuq in-naħa ta' wara taċ-chiller u huma tikkettati  (PROCESS OUTLET) u  (PROCESS INLET). Ikkonnettja l-  mal-fluid inlet fuq l-applikazzjoni tiegħek. Ikkonnettja l-  mal-fluid outlet fuq l-applikazzjoni tiegħek.

Għal water-cooled chillers ikkonnettja l-  (FACILITY INLET) mal-provvista tal-facility water tiegħek. Ikkonnettja l-  (FACILITY OUTLET) mal-facility water return jew drain tiegħek.

Qabel ma tistartja iċ-chiller, erġa' ċċekkja l-konnessjonijiet tal-komunikazzjoni, tal-elettriku u tal-plumbing applikabbli kollha.





**PL**

## **Ważne instrukcje dotyczące bezpieczeństwa Chłodziarki recyrkulacyjne**

W przypadku niezrozumienia którychkolwiek z niniejszych instrukcji, przed przystąpieniem do dalszych prac należy zapoznać się z instrukcją obsługi lub skontaktować się z nami.

### **Bezpieczeństwo, wszystkie produkty:**

 wskazuje na sytuację bezpośredniego zagrożenia, która bez podjęcia środków zaradczych doprowadzi do śmierci lub poważnych obrażeń ciała.

 wskazuje na sytuację potencjalnie niebezpieczną, która bez podjęcia środków zaradczych może doprowadzić do śmierci lub poważnych obrażeń ciała.

 wskazuje na sytuację potencjalnie niebezpieczną, która bez podjęcia środków zaradczych doprowadzi do drobnych lub umiarkowanych obrażeń ciała. Ponadto będzie wykorzystywana do zgłaszania niebezpiecznych zachowań.

 ostrzega użytkownika o nieizolowanym "niebezpiecznym napięciu" w obrębie obudowy chłodziarki. Wartość bezwzględna napięcia jest na tyle wysoka, by nieść za sobą ryzyko porażenia prądem elektrycznym.

 ostrzega przed gorącymi powierzchniami.

 nakazuje przeczytać instrukcję obsługi.

Nie używać sprzętu, jako urządzenia sterylnego ani mającego kontakt z pacjentem. Ponadto sprzęt nie jest przeznaczony do zastosowań w obrębie Lokalizacji Niebezpiecznych, Klasy I, II lub III określonych przez Krajowe Normy Elektryczne.

Sprzęt został stworzony wyłącznie do użytku wewnątrz pomieszczeń. Nigdy nie należy go umieszczać w miejscu, gdzie wystawiony będzie na działanie zbyt wysokich temperatur, wilgoci, materiałów powodujących korozję lub w lokalizacjach o nieodpowiedniej wentylacji. Aby zapoznać się z parametrami roboczymi, patrz instrukcja obsługi.

Sprzęt podłączyć do odpowiednio uziemionego gniazdka.

Wykorzystywane czynniki chłodnicze są cięższe od powietrza, dlatego w przypadku nieszczelności zastąpią tlen, co doprowadzi do utraty przytomności. Kontakt z wyciekającym czynnikiem chłodniczym doprowadzi

do poparzeń skóry. Aby uzyskać więcej informacji, patrz tabliczka znamionowa cyrkulatora, na której oznaczono typ wykorzystywanego czynnika chłodniczego, najnowsza karta charakterystyki substancji niebezpiecznej US (SDS) producenta wcześniej znana jako MSDS, a także karta charakterystyki substancji niebezpiecznej EU.

Podczas transportowania sprzętu niezbędne jest zachowanie należytej ostrożności. Nagle wstrząsy lub upadek mogą skutkować uszkodzeniem podzespołów. Przed przystąpieniem do transportowania sprzętu należy pamiętać o jego wyłączeniu oraz odłączeniu od napięcia zasilającego.

Nigdy nie obsługiwać uszkodzonego lub nieszczelnego sprzętu.

Nigdy nie stosować płynów palnych lub powodujących korozję. Korzystać wyłącznie z zatwierdzonych płynów wymienionych w instrukcji obsługi. Przed użyciem jakiegokolwiek płynu lub przystąpieniem do jakichkolwiek prac konserwacyjnych, gdy prawdopodobny jest kontakt z płynem patrz najnowsza karta charakterystyki substancji niebezpiecznej US (SDS), a także karta charakterystyki substancji niebezpiecznej EU.

Przed przystąpieniem do transportowania sprzętu należy pamiętać o jego wyłączeniu oraz odłączeniu od napięcia zasilającego.

Prace serwisowe oraz naprawcze należy zlecić wykwalifikowanemu technikowi.

Sprzęt należy przechowywać w temperaturach -25°C do 60°C (w opakowaniu) oraz przy zachowaniu <80% wilgotności względnej.

Wycofanie z eksploatacji może zostać przeprowadzone wyłącznie przez wykwalifikowanego sprzedawcę wykorzystującego sprzęt posiadający niezbędne atesty. Niezbędne jest przestrzeganie wszystkich obowiązujących przepisów.

Wykonywanie czynności montażowych, konserwacyjnych lub obsługa odbiegająca od wytycznych opisanych w instrukcji obsługi może skutkować niebezpiecznymi sytuacjami oraz utratą gwarancji producenta.

Nigdy nie stosować napięcia międzyprzewodowego na żadnym ze złączy komunikacyjnych chłodziarki.

Jeśli chłodziarka oraz przewody rurowe medium chłodzącego nie zostaną całkowicie wypelnione może to doprowadzić do uszkodzenia pompy chłodziarki. Unikać przepelnienia. Płyny pod wpływem ciepła zwiększają swoją objętość.

W przypadku ThermoFlex przed dokonaniem wymiany obudowy zbiornika zadbać o odpowiednie zabezpieczenie kulowego ogranicznika wskaźnika poziomu zbiornika.

W przypadku urządzenia ThermoFlex900-5000, chłodziarki nie należy używać, jeśli nie został zamontowany dyfuzor płynów zbiornika.

Jeśli chłodziarka wyposażona została w pompę wporową (P1 bądź P2) należy sprawdzić czy rury kanalizacyjne oraz łączniki są w stanie wytrzymać ciśnienie o wartości minimum 185 psi.

Nie stosować samochodowych płynów zapobiegających zamarzaniu. Komercyjne środki zapobiegające zamarzaniu zawierają krzemiany uszkadzające uszczelnienie pompy.

Aby zapobiec zamarzaniu/oblodzeniu wymiennika płytkowego w przypadku chłodziarek

ThermoFlex7500-24000 niezbędne jest stosowanie mieszaniny 50/50 EG/woda lub 50/50 PG/woda przy temperaturze procesu nieprzekraczającej 10°C.

W przypadku wykorzystywania mieszaniny mediów chłodzących tj. EG/woda lub PG/woda należy regularnie sprawdzać zarówno stężenie płynu, jak i pH. Zmiany stężenia i pH mogą wpłynąć na wydajność układu. Nie należy stosować wkładu filtra dejonizacyjnego (DI) ze stabilizowanym EG lub PG. Filtr DI usunie inhibitory z roztworu przez co płyn nie będzie zapewniał ochrony przeciwkorozyjnej. Ponadto, inhibitory zwiększają przewodność płynu.

Biocydy posiadają właściwości korozyjne i mogą doprowadzić do nieodwracalnego uszkodzenia oczu bądź poparzeń skóry. Wdychanie, połknięcie lub wchłonięcie przez skórę jest szkodliwe dla zdrowia. Patrz najnowsza charakterystyka substancji niebezpiecznej producenta.

Aby zapobiec uszkodzeniu płytki wymiennika chłodziarki niezbędne jest zapewnienie na pompie przepływu wynoszącego minimum 4,0 gpm (15,1 lpm).

Zaniechanie czyszczenia/wymian filtra kondensatora doprowadzi do spadku wydajności chłodniczej oraz przedwczesnej awarii układu chłodzenia. W celu dokładnego wyczyszczenia należy zdjąć okratowanie przednie.

W przypadku chłodziarek chłodzonych powietrzem, obramowanie kondensatora oraz żeberka znajdujące się za przednim okratowaniem mają bardzo ostre krawędzie. Podczas pracy wszystkie panele powinny znajdować się na swoich miejscach.

Wyjątkiem jest okratowanie zespołów chłodzonych powietrzem.

ThermoFlex900-5000 chłodzone wodą wyposażone zostały w wentylator posiadający ostre łopaty. Przed zdjęciem przedniego okratowania upewnić się, że chłodziarka została wyłączona.

## Przeznaczenie, Chłodziarki recyrkulacyjne:

Chłodziarki recyrkulacyjne Thermo Scientific zostały stworzone z myślą o ciągłym dostarczaniu płynu o stałej temperaturze i stałym tempie przepływu. Chłodziarka składa się z układu chłodzenia powietrzem lub wodą, wymiennika ciepła, pompy recyrkulacyjnej, zbiornika na płyn chłodniczy oraz sterownika mikroprocesorowego.

Chłodziarki zostały zaprojektowane do pracy ciągłej oraz do użytku w pomieszczeniach zgodnie ze wszystkimi procedurami i wymogami określonymi w ich instrukcjach obsługi.

## Instalacja, Chłodziarki recyrkulacyjne:

Chłodziarkę należy umieścić w pobliżu jej urządzenia wyłączającego pamiętając o zapewnieniu do niego łatwego dostępu.

Chłodziarkę należy podłączyć do przeznaczonego dla niej gniazdka.

Zadbać o to, aby przed instalacją zdemontowane zostały wszystkie zaślepki przewodów wodociągowych założone na czas transportu.

Złącza płynu chłodniczego znajdują się w tylnej części chłodziarki i zostały odpowiednio oznaczone etykietami  (PROCESS OUTLET - wylot) oraz  (PROCESS INLET - wlot). Podłączyć  do wlotu płynu po stronie zastosowania. Podłączyć  do wylotu płynu po stronie zastosowania.

W przypadku chłodziarek chłodzonych wodą podłączyć  (FACILITY INLET - wlot) do zasilania wodą zakładową. Podłączyć  (FACILITY OUTLET - wylot) do przewodu powrotnego wody zakładowej lub spustu.

Przed uruchomieniem chłodziarki należy ponownie sprawdzić wszystkie połączenia oraz złącza elektryczne i wodociągowe.

**RO**

## Instrucțiuni Esențiale de Siguranță Aparate frigorifice de recirculate

Consultați manualul sau contactați-ne înainte de a merge mai departe dacă oricare dintre aceste instrucțiuni sunt pe deplin înțelese.

**Siguranță, toate produsele:**

**DANGER** indică o situație periculoasă iminentă care, în cazul în care nu se evită, poate cauza moarte sau vătămare corporală gravă.

**WARNING** indică o situație potențial periculoasă care dacă nu se evită poate cauza moartea sau rănirea gravă.

**CAUTION** indică o situație potențial periculoasă care dacă nu se evită poate cauza răni minore sau moderate. Se folosește și pentru a atenționa împotriva practicilor periculoase.

 menit să atenționeze utilizatorul cu privire la prezența „voltajului periculos” neizolat din incinta aparatului frigorific. Magnitudinea voltajului este destul de mare pentru prezenta risc de șoc electric.

 indică prezenta suprafețelor încinse.

 indică citirea manualului.

Nu folosiți echipamentul ca dispozitiv steril sau dispozitiv conectat la pacient. În plus, echipamentul nu este conceput pentru a se folosi în Locuri Periculoase din Clasele I, II sau III conform definițiilor Codului Electric Național.

Echipamentul este conceput doar pentru uz intern. Nu se plasează niciodată în locuri sau unde se află niveluri crescute de căldură, umezeală sau substanțe corozive. Consultați manualul de utilizare pentru parametrării operaționale.

Conectați echipamentul la o priză împământată corespunzător.

Agenții frigorifici folosiți sunt mai grei decât aerului, iar dacă există o scurgere ei vor înlocui oxigenul și vor cauza pierderi de conștiență. Contactul cu scurgerile de agent frigorific poate cauza ardere la nivelul pielii. Consultați plăcuța de identificare a propagatorului pentru tipul de agent frigorific folosit și apoi cea mai actuală Fișă cu Date de Siguranță SUA(FDS) a producătorului cunoscută drept MSDS și Fișa cu Date de Siguranță UE pentru informații suplimentare.

Echipamentul se transportă cu grijă. Zguduiele sau căderile pot avaria componentele. Înainte de a-l transporta opriți mereu echipamentul și deconectați-l de la tensiunea de alimentare.

Nu operați niciodată echipament avariata sau care prezintă scurgeri.

Nu folosiți niciodată lichide inflamabile sau corozive. Folosiți numai lichidele aprobate care sunt enumerate în manual. Consultați cea mai actuală Fișă cu Date de Siguranță SUA (FDS) și Fișa cu Date de Siguranță UE pentru informații suplimentare înainte de folosi orice lichid sau de a efectua lucrări de întreținere când există șansa de a intra în contact cu lichide.

Înainte de a-l transporta opriți mereu echipamentul și deconectați-l de la tensiunea de alimentare.

Reparațiile și întreținerea se efectuează de către tehnicienii calificați.

Echipamentul se depozitează la temperaturi afte între -25°C to 60°C (cu ambalaj) și <80% umiditate relativă.

Retragerea din funcționare se efectuează numai de către un furnizor calificat folosind echipament certificat. Trebuie să se respecte toate prevederile curente.

Performanța instalației, operarea sau procedurile de întreținere pe lângă cele descrise în manual pot să cauzeze situații periculoase sau se anuleze garanția producătorului.

Niciodată să nu aplicați tensiune de linie la conexiunile de comunicare ale aparatului frigorific.

Pompa aparatului frigorific ar putea fi avariata dacă aparatul frigorific nu se umple complet și dacă țevile pentru lichidul de procesare sunt avariate. Evitați umplerea în exces. Lichidele se dilată la căldură.

Asigurați-vă că bila de oprire de la indicatorul de nivel al rezervorului este bine fixată înainte de a pune carcasa rezervorului pentru ThermoFlex.

În cazul ThermoFlex900-5000, nu operați aparatul frigorific decât dacă difuzorul de lichid al rezervorului este instalat.

Dacă aparatul frigorific este echipat cu o pompă de refulare (P1 sau P2), asigurați-vă că liniile de instalație și garniturile sunt capabile să reziste la cel puțin 185 psi.

În cazul aparatelor de răcire Merlin cu pompe MD nu se restricționează niciodată complet curgerea pentru aplicație. Blocarea pompei avariază cuplajul și va fi necesară înlocuirea pompei.

Nu folosiți antigel pentru automobile. Antigetul comercial conține silicați care pot avaria izolația pompei.

Pentru a preveni înghețarea schimbătorului de placă, aparatele frigorifice ThermoFlex7500-24000 necesită folosirea apei50/50 EG/ sau a apei 50/50 PG/ sub 10°C-temperatură de procesare.

Când se folosește un ameste de lichid de procesare cu apă/EG sau apă/PG se verifică regulat concentrația lichidului și a pH-ului. Schimbările concentrației și a Ph-ului afectează randamentul instalației. Nu folosiți cartuș de filtrare deionizant cu EG Inhibat sau PG Inhibat.

Filtrul deionizant va îndepărta inhibitorii din soluție, iar lichidul nu va avea niciun efect de protecție împotriva coroziei. De asemenea, inhibitorii vor mări conductivitatea lichidului.

Biocidele au efect coroziv și pot cauza răni ireversibile la nivelul ochilor și arsurii de piele. Sunt toxice dacă se inhalează, dacă se înghit sau dacă se absorb prin piele. Consultați cea mai recentă Fișă cu Date de Siguranță de la producător.

Pompele centrifugale au nevoie de o rată minimă de curgere de 4.0 gpm (15.1 lpm) pentru a preveni avarierea schimbătorului de placă al aparatului frigorific.

Dacă nu se curăță înlocuiește filtrul de condensare se poate ajunge la scăderea capacității de răcire și la erori premature ale sistemului de răcire. Pentru a efectua curățarea în profunzime se îndepărtează ansamblul frontal de grilaj.

La aparatele frigorifice răcite cu aer, cadrul și muchiile de condens din spatele grilajului frontal sunt foarte ascuțite.

Nu operați aparatul frigorific dacă panourile sunt îndepărtate în afară de ansamblul de grijale pentru răcire cu aer.

Aparatele frigorifice ThermoFlex900-5000 răcite cu apă au un ventilator cu lame ascuțite. Asigurați-vă că aparatul frigorific este scos din funcțiune înainte să îndepărtați grilajul.

### Scop de utilizare, Aparate frigorifice cu Recirculare:

Aparatele frigorifice Thermo Scientific sunt concepute pentru a asigura alimentarea continuă cu lichid la temperatură și rată de curgere constantă. Aparatul frigorific este alcătuit din sistem frigorific răcit cu aer sau cu apă, un schimbător de căldură, pompă de recirculare, rezervor pentru lichid de procesare și un controler cu microprocesor.





Aparatele frigorifice sunt concepute pentru operare continuă și pentru uz intern conform tuturor procedurilor și condițiilor prevăzute în manualul lor.

### Instalare, Aparat frigorific cu recirculare:

Plasați aparatul frigorific în așa fel încât să fie aproape și să aibă acces ușor la aparatul de deconectare.

Aparatul frigorific este conceput pentru a se folosi la o priză dedicată.

Asigurați-vă că toate mufele de transport de la linia de instalație s-au îndepărtat înainte de instalare.

Conexiunile pentru lichid de procesare se găsesc pe latura din spate a aparatului de răcire și sunt etichetate  (PROCESS OUTLET) (EVACUARE PROCES) și  (PROCESS INLET) (ADMISIE PROCES). Conectați  la admisia de lichid de la aplicația dumneavoastră. Conectați  la evacuarea de lichid de la aplicația dumneavoastră.

Pentru aparatele frigorifice răcite cu apă se conectează  (ADMISIE INSTALAȚIE) la instalația de alimentare cu apă. Conectați  (FACILITY INLET) (EVACUARE INSTALAȚIE) la instalația de întoarcere sau scurgere pentru apă.

Înainte să porțiți aparatul frigorific verificați de două ori comunicarea aplicabilă, conexiunile electrice și conexiunile de la instalație.



## Osnovna varnostna navodila Recirkulacijski ohlajevalniki

Če ne razumete kategorikoli navodila, si poglejte navodila za uporabo ali stopite v stik z nami, še preden nadaljujete.

### Varnost - vsi izdelki:

**⚠ DANGER** Opozarja na akutne nevarne okoliščine, ki lahko – če se jim ne izognete – povzročijo resne ali celo smrtne nevarne poškodbe.

**⚠ WARNING** Opozarja na morebitno nevarne okoliščine, ki lahko – če se jim ne izognete – povzročijo resne ali celo smrtne nevarne poškodbe.

**⚠ CAUTION** Opozarja na akutne nevarne okoliščine, ki lahko – če se jim ne izognete – povzročijo lažje ali srednje nevarne poškodbe. Uporablja se tudi kot opozorilo proti nevarni praksi.

 opozarja na bližino neizolirane nevarne napetosti v ohišju ohlajevalnika. Napetost je dovolj visoka, da lahko povzroči električni šok.

 opozarja na vroče površine.

 opozarja, da je potrebno prebrati navodila.

Ne uporabljajte aparata kot sterilno napravo, ali napravo, povezane z bolnikom. Poleg tega naprava ni načrtovana za uporabo v napravah, ki delujejo v nevarnih okoljih I., II. in III. razreda po določilih Nacionalnega pravilnika za električne naprave.

Naprava je načrtovana za uporabo v zaprtih prostorih. Nikoli ne postavite naprave na mesto z visoko temperaturo, vlago, nezadostnim prezračevanjem in jedkimi snovmi. Delovni parametri so navedeni v navodilih.

Priključite napravo v pravilno ozemljeno vtičnico.

Uporabljena hladilna sredstva so težja od zraka. Če obstajajo netesna mesta, bodo izpodrlnila kisik in povzročila izgubo zavesti. Stik z uhajajočim hladilnim sredstvom bo povzročil ozeblino. Dodatne informacije boste našli na cirkulatorjevi ploščici s podatki, na kateri je naveden tip hladilnega sredstva, najnovjšem varnostnem listu za ZDA (SDS), ki je bil prej poznan pod nazivom MSDS in varnostnem listu za EU.

Previdno premikajte opremo. Nenadni sunki ali padci lahko poškodujejo njene dele. Preden premikate opremo, jo vedno izklopite in odklopite z omrežnega napajanja.

Nikoli ne delajte z opremo, ki je poškodovana ali pušča.

Nikoli ne uporabljajte vnetljivih ali jedkih tekočin. Uporabite le odobrene tekočine, navedene v predmetnih navodilih za uporabo. Preden uporabite katerokoli tekočino ali opravite vzdrževanje, pri katerem je verjeten stik s tekočino preglejte najnovjši varnostni list ZDA (SDS) in varnostni listu EU, kjer bosta našli podrobnejše informacije.

Preden premikate opremo, jo vedno izklopite in odklopite z omrežnega napajanja.

Servis in popravila lahko izvaja le ustrezno usposobljen tehnik

Shranite opremo pri temperaturi med -25 °C in 60 °C (z embalažo) in relativno zračno vlago <80 %.

Razgradnjo naprave lahko opravi le ustrezno usposobljen zastopnik, ki uporablja odobreno opremo.

Uporabljajte vse veljavne zadevne predpise.

Izvajanje kakršnihkoli postopkov, povezanih z montažo, delovanjem ali vzdrževanjem, ki niso navedeni v teh navodilih, lahko povzroči nevarne okoliščine in izniči veljavnost garancije proizvajalca.

Nikoli ne priključite omrežne napetosti na katerikoli komunikacijski priključek ohlajevalnika.

Če ohlajevalnik in cevi za procesni medij niso polni, lahko slednje poškoduje črpalno ohlajevalnika.

Preprečite prenapoljenost, tekočine se pri ogrevanju raztezajo.

Pri modelu ThermoFlex pred zamenjavo ohišja rezervoarja preverite, ali je krogelni ventil s pregledno cevjo pravilno nameščen.

Pri modelu ThermoFlex900-5000 ne vklopite ohlajevalnika, če ni nameščen difuzor za tekočino v rezervoarju.

Če je ohlajevalnik opremljen s črpalno, ki ima pozitivni izpodriv (P1 ali P2), poskrbite, da vodovodne cevi in fitingi prenesejo tlak vsaj 12,8 bar (185 PSI).

Ne uporabljajte avtomobilskega antifriz. Antifrizi iz redne prodaje vsebujejo silikate, ki lahko poškodujejo tesnila črpalke.

Zaradi preprečevanja zmrzovanja/zaledenitve ploskega izmenjevalnika, zahtevajo ohlajevalniki

ThermoFlex7500-24000 uporabo 50/50 EG/voda ali 50/50 PG/voda pri procesni temperaturi, nižji od 10 °C.

Če uporabljate procesno tekočino EG/voda ali PG/voda, redno preverjajte koncentracijo in pH tekočine.

Spremembe koncentracije in pH lahko vplivajo na zmogljivost sistema.

Ne uporabite kartuše deionizacijskega (DI) filtra z inhibiranim EG ali PG. Filter DI bo odstranil inhibitorje iz raztopine, kar pomeni, da tekočina ne bo več ščitila pred korozijo. Inhibitorji poleg tega povečajo prevodnost tekočine.

Biocidi so korozivni in lahko nepopravljivo poškodujejo oči in povzročijo kožne opekline. Škodljivo pri vdihavanju, zaužitju ali absorpciji skozi kožo. Preverite proizvajalčev najnovjši SDS.

Zaradi preprečevanja poškodb ohlajevalnikovega ploščatega izmenjevalnika, zahteva centrifugalna črpalka pretok najmanj 4,0 g/m (15,1 l/m).

Če ne očistite/zamenjate filtra kondenzatorja, lahko slednje povzroči zmanjšanje hladilne zmogljivosti in predčasno odpoved hladilnega sistema. Pri temeljitem čiščenju odstranite prednjo masko.

Pri zračno hlajenih ohlajevalnikih so okvir in lamele, ki se nahajajo za prednjo rešetko zelo ostri.

Razen pri zračno hlajenem sklopu mreže nikoli ne uporabljajte ohlajevalnika, če je odstranjen katerikoli panel.

Vodno hlajeni ohlajevalniki ThermoFlex900-5000 imajo ventilatorje z ostrimi lopaticami. Preverite ali je ohlajevalnik izklopljen preden odstranite prednjo mrežo.

### **Namenska uporaba, reciklacijski ohlajevalniki:**

Reciklacijski ohlajevalniki Thermo Scientific so načrtovani za nenehen dovod tekočine z enokomerno temperaturo in pretokom. Ohlajevalnik je sestavljen iz zračno ali vodno hlajenega hladilnega sistema, toplotnega izmenjevalnika, obtočne črpalke, rezervoarjem procesirane tekočine





Ohlajevalniki so načrtovani za neprekinjeno obratovanje v zaprtih prostorih v skladu z vsemi postopki in zahtevami, navedenimi v tem priročniku.

### **Namestitev, ohlajevalnik z reciklacijo:**

Namestite ohlajevalnik v bližino, da imate enostaven dostop do odklopne naprave.

Ohlajevalnik je namenjen za uporabo na posebni vtičnici.

Pred montažo preverite, ali so z vseh cevi odstranjeni transportni čepi.

Procesne povezave za tekočino se nahajajo na zadnji strani ohlajevalnika in so ustrezno označene  PROCESS OUTLET (PROCESNA VTIČNICA) in  PROCESS INLET (PROCESNI DOVOD). Priključite  na vhod za tekočine vaše aplikacije. Priključite  na dovod za tekočine vaše aplikacije.

Pri vodno hlajenih ohlajevalnikih prikjučite  FACILITY INLET (DOVOD NAPRAVE) na dovod vaše naprave. Priključite  FACILITY OUTLET (ODVOD NAPRAVE) na povratni vod ali iztok vaše naprave.

Pred vklopom ohlajevalnika dvakrat preverite vse razpoložljive komunikacije ter električne in vodovodne povezave.

## Osnovna bezbednosna uputstva Cirkulirajući rashladni uređaji

Ako ne razumete bilo koja od ovih uputstava, pogledajte priručnik ili nas kontaktirajte pre nego što nastavite.

**Bezbednost, svi proizvođači:**

 označava neposrednu opasnost koja, ako se ne izbegne, će da dovede do smrti ili teške povrede.

 označava potencijalno opasnu situaciju koja, ako se ne izbegne, može da dovede do smrti ili teške povrede.

 označava potencijalno opasnu situaciju koja, ako se ne izbegne, može da dovede do lakše ili srednje teške povrede. Takođe može da se koristi da upozori na nesigurne radnje.

 upozorava korisnika na prisustvo neizolovanog „opasnog napona“ unutar kućišta rashladnog uređaja. Napon je dovoljno velik da predstavlja opasnost od strujnog udara.

 ukazuje na prisustvo vrelih površina.

 ukazuje da je potrebno pročitati priručnik.

Nemojte da koristite opremu kao sterilni uređaj ili uređaj povezan na pacijenta. Pored toga, oprema nije predviđena za upotrebu na opasnim lokacijama klase I, II ili III prema definicijama Nacionalnog električnog standarda (engl. National Electrical Code).

Oprema je predviđena samo za upotrebu u zatvorenim prostorima. Nikad nemojte da je postavljate gde je prisutna prekomerna toplota, vlažnost, neodgovarajuće provetravanje ili nagrizajući materijali. Radni parametri navedeni su u priručniku.

Povežite opremu na pravilno uzemljenu utičnicu.

Korišćena sredstva za hlađenje su teža od vazduha a i, ako dođe do curenja, zamenite kiseonik te dovesti do gubitka svesti. Kontakt sa sredstvom za hlađenje koje curi uzrokuje opekotine. Pogledajte pločicu s podacima cirkulatora za vrstu korišćenog sredstva za hlađenje, a zatim potražite dodatne informacije u najnovijem bezbednosnom listu za SAD (engl. Safety Data Sheet; SDS), ranije poznatom kao MSDS, kao i bezbednosnom listu za EU.

Oprezno pomerajte opremu. Naglo diranje ili ispuštanje opreme može da ošteti njene komponente. Pre pomeranja opreme uvek je isključite i iskopčajte iz napona izvora napajanja.

Nikad nemojte da koristite oštećenu opremu ili opremu koja propušta.

Nikad nemojte da koristite zapaljive ili nagrizajuće tečnosti. Koristite samo odobrene tečnosti koje su navedene u priručniku. Pre korišćenja bilo kakve tečnosti ili obavljanja postupaka održavanja u kojima će verovatno doći do kontakta s tečnošću, potražite dodatne informacije u najnovijem bezbednosnom listu za SAD (engl. Safety Data Sheet; SDS) i bezbednosnom listu za EU.

Pre pomeranja opreme uvek je isključite i iskopčajte iz napona izvora napajanja.

Servisiranje i popravke treba da obavlja kvalifikovani serviser.

Opremu držite na rasponu temperature od -25 °C do 60 °C (s pakovanjem) i relativnoj vlažnosti od <80 %.

Stavljanje izvan pogona mora da obavi isključivo kvalifikovani trgovac pomoću certifikovane opreme. Mora da se pridržava svih važećih propisa.

Obavljanje postupaka ugradnje, korišćenja ili održavanja koji nisu opisani u priručniku može da dovede do opasne situacije i poništiće garanciju proizvođača.

Nikad nemojte da primerjujete linijski napon na komunikacijske priključke na rashladnom uređaju.

Ako ne napunite rashladni uređaj i creva za radnu tečnost do kraja, može da dođe do oštećenje pumpe rashladnog uređaja. Nemojte da prepunjavate jer se tečnost širi prilikom zagrevanja.

Na rashladnom uređaju ThermoFlex, pre zamene kućišta rezervoara potrebno je proveriti da čep indikatora nivoa u rezervoaru bude čvrsto na mestu.

Rashladni uređaj ThermoFlex900-5000 nemojte da koristite ako difuzor rezervoara nije ugrađen.

Ako je rashladni uređaj opremljen volumetrijskom pumpom (P1 ili P2), pazite da vodovodna creva i spojnice mogu da podnesu najmanje 185 psi.

Nemojte da koristite antifriz za automobile. Komerциjalni antifriz sadrži silikate koji oštećuju zaprtivke pumpe.

Da bi se sprečilo smrzavanje pločastog izmenjivača, rashladni uređaji ThermoFlex7500-24000 zahtevaju upotrebu mešavine od 50/50 etilen glikola/vode ili 50/50 propilen glikola/vode na radnoj temperaturi ispod 10 °C.

Prilikom upotrebe mešavine radne tečnosti od etilen glikola/vode ili propilen glikola/vode, redovno proveravajte koncentraciju tečnosti i pH vrednost. Promene u koncentraciji i pH vrednosti mogu da utiču na performanse sistema .

Nemojte da koristite uložak filtera za dejonizaciju s inhibiranim etilen glikolom ili inhibiranim propilen glikolom. Filter za dejonizaciju uklanja inhibitore iz rastvora, što tečnost čini neefikasnom za zaštitu od korozije. Pored toga, inhibitori povećavaju provodljivost tečnosti.

Biocidi su nagrizajući i mogu da dovedu do nepopravljivih oštećenja očiju i opekotina. Štetni su ako se udahnu, progutaju ili upiju kroz kožu. Pogledajte najnoviji bezbednosni list proizvođača.

Da bi se sprečilo oštećenje pločastog izmenjivača rashladnog uređaja, centrifugalne pumpe zahtevaju minimalni protok od 4,0 g/min (15,1 l/min).

Ako se filter kondenzatora ne čisti/menja, dolazi do gubitka kapaciteta hlađenja i prevremenog kvara sistema hlađenja. Za temeljito čišćenje uklonite sklop prednje rešetke.

Na vazduhom hlađenim rashladnim uređajima okvir i vertikalni stabilizatori kondenzatora nalaze se iza sklopa prednje rešetke i vrlo su oštri.

S izuzetkom vazduhom hlađenog sklopa rešetke nikad nemojte da koristite rashladni uređaj kad je bilo koja ploča skinuta.

Vodnom hlađeni rashladni uređaji ThermoFlex900-5000 imaju ventilator s oštrim lopaticama i zato rashladni uređaj morate da isključite pre skidanja prednje rešetke.

### **Namena, cirkulirajući rashladni uređaji:**

Cirkulirajući rashladni uređaji kompanije Thermo Scientific su predviđeni za pružanje neprekidne isporuke tečnosti uz konstantnu temperaturu i protok. Rashladni uređaj se sastoji od vazduhom hlađenog ili vodnom hlađenog rashladnog sistema, izmenjivača toplote, cirkulirajuće pumpe, rezervoara radne tekućine i kontrolera mikroprocesora.

Rashladni uređaji su predviđeni za neprekidan rad i upotrebu u zatvorenim prostorima u skladu sa svim postupcima i zahtevima navedenim u njihovim priručnicima.

### **Ugradnja, cirkulirajući rashladni uređaji:**

Postavite rashladni uređaj tako da bude blizu i ima lak pristup svom uređaju za iskopčavanje.

Rashladni uređaj je predviđen za upotrebu na namenskoj utičnici.

Obavezno skinite sve ambalažne čepove vodovodnih creva pre ugradnje.

Priključni rashladne tekućine nalaze se sa zadnje strane rashladnog uređaja i označeni su sa  (PROCESS OUTLET) (radni izlazni otvor) i  (PROCESS INLET) (radni ulazni otvor). Povežite  na ulazni otvor za tečnost na uređaju. Povežite  na izlazni otvor za tečnost na uređaju.

Kod vodnom hlađenim rashladnim uređajima povežite  (FACILITY INLET) (ulazni otvor za postrojenje) na vodosnabdevanje postrojenja. Povežite  (FACILITY OUTLET) (izlazni otvor postrojenja na povratni vod ili odvod postrojenja).

Pre pokretanja rashladnog uređaja dvaput proverite sve relevantne komunikacijske, električne i vodovodne priključke.



**SK**

## Základné bezpečnostné pokyny Recirkulačné chladiace jednotky

Ak nerozumiete niektorému z týchto pokynov, pred pokračovaním si prečítajte príručku alebo nás kontaktujte.

### Bezpečnosť, všetky produkty:

**⚠ DANGER** označuje bezprostredne nebezpečnú situáciu, ktorá, ak sa jej nevyhnete, spôsobí usmrtenie alebo vážne poranenie.

**⚠ WARNING** označuje potenciálne nebezpečnú situáciu, ktorá, ak sa jej nevyhnete, môže spôsobiť usmrtenie alebo vážne poranenie.

**⚠ CAUTION** označuje potenciálne nebezpečnú situáciu, ktorá, ak sa jej nevyhnete, môže spôsobiť ľahké alebo stredne ťažké poranenie. Používa sa aj ako varovanie pred nebezpečnými postupmi.

 slúži na upozornenie používateľa na prítomnosť neizolovaného „nebezpečného napätia“ pod krytom chladiacej jednotky. Napätie je dostatočne vysoké na to, aby predstavovalo riziko úrazu elektrickým prúdom.

 označuje prítomnosť horúcich povrchov.

 označuje nutnosť prečítania príručky.

Zariadenie nepoužívajte ako sterilné alebo ako zariadenie pripojené k pacientovi. Zariadenie okrem toho nie je určené na použitie v nebezpečných prostrediach triedy I, II alebo III definovaných kódom NEC (National Electrical Code).

Zariadenie je určené len na použitie v interiéri. Nikdy ho neumiestňujte na mieste, kde je prítomné nadmerné teplo, vlhkosť, nedostatočné vetranie alebo korozívne materiály. Prečítajte si prevádzkové parametre uvedené v príručke.

Zariadenie pripojte k správne uzemnenej zásuvke.

Použitie chladiča sú ťažšie ako vzduch a ak dôjde k úniku, nahradia kyslík a spôsobia stratu vedomia.

Kontakt s unikajúcim chladičom môže spôsobiť popálenie pokožky. Typ použitého chladiča nájdete na typovom štítku obehového čerpadla a ďalšie informácie nájdete v poslednej karte bezpečnostných údajov (KBÚ) pre USA, predtým známej ako MSDS a karte bezpečnostných údajov pre EÚ.

Zariadenie presúvajte opatrne. Náhle otrasy alebo pády môžu poškodiť jeho komponenty. Pred každým presúvaním vypnite zariadenie a odpojte ho od napájacieho napätia.

Nikdy nepoužívajte poškodené alebo netesné zariadenie.

Nikdy nepoužívajte horľavé alebo korózne kvapaliny. Používajte iba schválené kvapaliny uvedené v návode na použitie. Pred použitím akejkoľvek kvapaliny alebo vykonaním údržby, kde je pravdepodobný kontakt s kvapalinou, si prečítajte poslednú kartu bezpečnostných údajov (KBÚ) pre USA a kartu bezpečnostných údajov pre EÚ, v ktorých nájdete ďalšie informácie.

Pred každým presúvaním vypnite zariadenie a odpojte ho od napájacieho napätia.

Servis a opravy prenechajte kvalifikovanému technikovi.

Zariadenie skladujte pri teplotách -25 °C až 60 °C (s obalom) a pri relatívnej vlhkosti <80 %.

Vyradenie z prevádzky môže vykonať len oprávnený predajca pomocou certifikovaného vybavenia. Je nutné dodržiavať všetky platné zákonné ustanovenia.

Vykonanie inštalácie, prevádzky alebo postupov údržby, ktoré nie sú popísané v tomto návode, môže viesť k nebezpečným situáciám a bude viesť k zrušeniu platnosti záruky výrobcu.

Nikdy nepripájajte sieťové napätie k niektorému z komunikačných pripojení na chladiacej jednotke.

Neuplné naplnenie chladiacej jednotky a potrubí s procesnými kvapalinami môže poškodiť čerpadlo chladiacej jednotky. Zabráňte prepĺneniu, kvapaliny sa po zohrnutí rozťahujú.

Pred opätovným nasadením krytu nádržky na jednotkách ThermoFlex zaistite, aby bola guľová záružka potrubia nádrže bezpečne na svojom mieste.

Pri jednotkách ThermoFlex900-5000 neprevádzkujte chladiacu jednotku, kým nie je nainštalovaný difúzor kvapaliny v nádržke.

Ak je chladiaca jednotka vybavená objemovým čerpadlom (P1 alebo P2), zaistite, aby inštalované potrubia a tvarovky boli dimenzované tak, aby odolali tlaku minimálne 185 psi.

Nepoužívajte automobilovú nemrznúcu kvapalinu. Komerčné nemrznúce zmesi obsahujú silikáty, ktoré poškodzujú tesnenia čerpadla.

Aby sa zabránilo zamrznutiu/zaneseniu doskového výmenníka, chladiace jednotky

ThermoFlex7500-24000 vyžadujú použitie kvapaliny 50/50 EG/voda alebo 50/50 PG/voda pri procesnej teplote do 10 °C.

Pri použití zmesi procesnej kvapaliny EG/voda alebo PG/voda v pravidelných intervaloch kontrolujte koncentráciu kvapaliny a pH. Zmeny v koncentrácii a pH môžu mať vplyv na výkon systému.

Nepoužívajte deionizačné (DI) filtračné vložky s inhibovanou EG alebo inhibovanou PG.

Filter DI odstráni inhibitory z roztoku a spôsobí, že bude mať kvapalina neúčinnú protikoroziu ochranu. Inhibitory tiež zvyšujú vodivosť kvapaliny.

Biocidy sú korózne a môžu spôsobiť nevratné poškodenie očí a popálenie pokožky. Sú škodlivé pri vdychnutí, požití alebo pri absorpcii cez pokožku. Prečítajte si poslednú KBÚ výrobcu.

Aby nedošlo k poškodeniu doskového výmenníka chladiacej jednotky, odstredivé čerpadlá musia mať minimálny prietok 4,0 g/min (15,1 l/min).

Ak nevyščistíte/nevymeníte filter kondenzátora, dôjde k strate chladiaceho výkonu a k predčasnému zlyhaniu chladiaceho systému. Pre dôkladné vyčistenie vyberte zostavu prednej mriežky.Na vzduchom chladených chladiacich jednotkách sú rám a lopatky umiestnené za zostavou prednej mriežky veľmi ostré.

V prípade iných ako vzduchom chladených zostáv mriežky nikdy neprevádzkujte chladiace jednotky, ak je odstránený akýkoľvek panel.

Vodou chladené chladiace jednotky ThermoFlex900-5000 majú ventilátor s ostrými čepelami. Pred vybratím prednej mriežky sa uistite, že je chladič vypnutý.

### Určené použitie, recirkulačné chladiace jednotky:

Recirkulačné chladiace jednotky Thermo Scientific sú navrhnuté na nepretržitú dodávku kvapaliny pri konštantnej teplote a prietoku. Chladiaca jednotka pozostáva z chladiaceho systému alebo vzduchom chladeného alebo vodou chladeného výmenníka tepla, recirkulačného čerpadla, nádrže na procesnú kvapalinu a mikroprocesorového regulátora.



Chladiace jednotky sú určené na nepretržitú prevádzku a na vnútorné použitie v súlade so všetkými postupmi a požiadavkami uvedenými v príslušnom návode na použitie.

### Inštalácia, recirkulačné chladiace jednotky:

Chladiacu jednotku umiestnite tak, aby bola blízko odpojacieho zariadenia, aby bol k nemu ľahký prístup.

Chladiaca jednotka je určená na pripojenie k vyhradenej zásuvke.

Uistite sa, že sú pred inštaláciou odstránené všetky prepravné zátky inštalátorských potrubí.

Pripojky pre procesnú kvapalinu sú umiestnené na zadnej strane chladiacej jednotky a sú označené ako  (PROCESS INLET) (PROCESNÝ VÝSTUP) a  (PROCESS OUTLET) (PROCESNÝ VÝSTUP) a  (PROCESS INLET) (PROCESNÝ VÝSTUP). Pripojte  k vstupu kvapaliny na vašej aplikácii. Pripojte  k výstupu kvapaliny na vašej aplikácii.

V prípade vodou chladených chladiacich jednotiek pripojte  FACILITY INLET (VSTUP ZARIADENIA) k prívodu vody zariadenia. Pripojte  (FACILITY OUTLET) (VÝSTUP ZARIADENIA) k návratu alebo odvodu vody zariadenia.

Pred spustením chladiacej jednotky dvakrát skontrolujte všetky príslušné komunikačné, elektrické a vodovodné pripojky.

## Viktiga säkerhetsinstruktioner Atercirkulerande kylare

Om någon av dessa anvisningar är svåra att förstå se handboken eller kontakta oss innan du går vidare.

### Säkerhet, alla produkter:

**⚠ DANGER** anger en imminent riskfylld situation som, om den inte undviks, resulterar i allvariga skador eller dödsfall.

**⚠ WARNING** anger en riskfylld situation som, om den inte undviks, kan resultera i dödsfall eller allvarlig skada.

**⚠ CAUTION** anger en riskfylld situation som, om den inte undviks, kan resultera i lättare eller medelsvåra skador. Den ska även användas för att varna om riskfyllda metoder.

 avsedd för att varna användaren om ej isolerad "farlig spänning" inuti kylarens hölje. Spänningen är tillräckligt hög för att utgöra en risk för eichock.

 anger att det finns heta ytor.

 anger att man bör läsa i handboken.

Använd inte utrustningen som steril eller ansluten till patient. Utrustningen är heller inte designad för användning i riskfyllda miljöer Klass I, II eller III, enligt definition i Nationella elbestämmelser.

Utrustningen är endast designad för inomhusbruk. Placera den aldrig på en plats med hög värme, fuktighet, otillräcklig ventilation eller där det förekommer frätande ämnen. Se handboken för driftsparametrar.

Anslut utrustningen till ett korrekt jordat uttag.

Kylmedium som används är tyngre än luft och kommer, om en läcka uppstår, att tränga ut syre vilket orsakar medvetlöshet. Kontakt med läckande kylmedium orsakar brännskador på hud. Se cirkulationspumpens namnskytt för typ av kylmedium som används och sedan tillverkarens aktuella US Säkerhetsdatablad (SDS), tidigare kallat MSDS, och EU Säkerhetsdatablad för ytterligare information.

Flytta utrustningen varsamt. Plötsliga ryck eller fall kan skada dess komponenter. Stäng alltid av utrustningen och koppla bort strömförsörjningen innan den flyttas.

Använd aldrig skadad eller läckande utrustning.

Använd aldrig brandfarliga eller frätande vätskor. Använd endast godkända vätskor som listas i handboken. Innan man använder vätskor eller utför underhåll där man troligen kommer i kontakt med vätskor ska man se tillverkarens aktuella US Säkerhetsdatablad (SDS) och EU Säkerhetsdatablad för ytterligare information.

Stäng alltid av utrustningen och koppla bort strömförsörjningen innan den flyttas.

Överåt service och reparationer till en behörig tekniker.

Förvara utrustningen inom temperaturområdet -25°C till 60°C (i förpackning) och <80 % relativ luftfuktighet.

Urtagning ur drift för endast utföras av behörig återförsäljare med certifierad utrustning. Alla gällande bestämmelser måste följas.

Installations-, drift- eller underhållsprocedurer, förutom de som beskrivs i handboken, kan resultera i riskfyllda situationer och kommer att upphäva tillverkarens garanti.

Applicera aldrig nätspänning till någon av kylarens kommunikationsanslutningar.

Om man inte fyller kylaren och processvätskeledningar helt så kan kylarens pump skadas. Undvik övertfyllning. Vätskor expanderar när de värms upp.

Innan man byter ut behållaren på ThermoFlex, så måste man försäkra att kulan i siktröret sitter säkert på plats.

På ThermoFlex900-5000 får man inte använda kylaren om vätskediffusern inte är installerad på behållaren.

På ThermoChill får man inte fylla över läppen, då vätska kommer att läcka ut vid tankens topp över komponenterna inuti kylaren.

Om din kylare har en positiv displacementpump (P1 eller P2), ska du försäkra att ledningarna är klassade för ett tryck på minst 185 psi.

Använd inte kylmedel för bilar. Kommersiella frysskydd innehåller silikat som skadar pumpens tätningar.

För att undvika frysningsfrost av plattvärmeväxlaren, så kräver kylarna ThermoFlex7500-24000 att man använder 50/50 EG/vatten eller 50/50 PG/vatten under 10°C processstemperatur.

När man använder en vätskeblandning med EG/vatten eller PG/vatten, så ska man kontrollera vätskekoncentrationen och pH-värdet regelbundet. Ändringar i koncentration och pH-värde kan påverka systemets prestanda.

Använd inte avjoningsfilter (DI) med inhiberat EG eller inhiberat PG. Ett avjoningsfilter avlägsnar inhibitorer från lösningen vilket gör vätskan ineffektiv mot rost. Inhibitorer höjer även vätskans konduktivitet.

Biocider är frätande och kan orsaka permanenta skador på ögon och brännskador på huden. De är skadliga vid inandning, förtäring eller om de absorberas genom huden. Se tillverkarens aktuella SDS.

För att förebygga skador på kylarens plattvärmeväxlare, så kräver centrifugalpumparna ett flöde på minst 4,0 gpm (15,1 lpm).

Om man inte rengör/ersätter kondesatorfiltret föröror man kylningsprestanda, vilket snabbare leder till fel i kylningssystemet. För en grundlig rengöring så avlägsnar man frontgallret.

På luftkylda kylare så är kondensatorns ram och fenor bakom gallret mycket skarpa.

Förutom med det luftkylda gallret så ska man aldrig starta kylaren med någon panel borttagen.

ThermoFlex900-5000 vattenkylda kylare har en fläkt med skarpa blad, så försäkra att kylaren är avstängd innan frontgallret avlägsnas.

### **Avsedd användning, Återcirkuleringskylare:**

Återcirkuleringskylare från Thermo Scientific är designade för att tillhandahålla kontinuerligt vätskeflöde vid en konstant temperatur och hastighet. Kylaren består av ett lyft- eller vattenkyllt kylningssystem, värmeväxlare, återcirkuleringspump, behållare för processvätska och en styrmodul med mikroprocessor.

Kylare är designade för kontinuerlig drift och för inomhusbruk i enlighet med alla procedurer och krav som anges i denna handbok.

### **Installation, Återcirkulerande kylare:**

Placera kylaren så att den befinner sig nära, med enkel åtkomst till, dess avstängningsanordning.

Kylaren är avsedd för att användas med ett för detta avsett uttag.

Försäkra att alla transportskydd avlägsnas från rör innan installation.

För att förebygga skador vid installation/borttagning av rören på Polar-kylare, så ska man använda en 19 mm nyckel på de externa anslutningarna-

Processvätskornas anslutningar sitter på kylarens baksida och är märkta med  (PROCESS INLET) och  (PROCESS OUTLET). Anslut  till vätskeinloppet på er applikation. Anslut  till vätskeutloppet på er applikation.

För vattenkylda kylare så ansluter man  (FACILITY INLET) till er anläggnings vattenförsörjning. Anslut  (FACILITY OUTLET) till er anläggnings vattenretur eller avlopp.

Innan kylaren startas så ska man dubbelkolla alla kommunikationer, samt elektriska och avloppsanslutningar.



## **Fluorinated Greenhouse Gases**

The following information is included to comply with REGULATION (EU) No 517/2014 OF THE EUROPEAN PARLIAMENT AND OF THE COUNCIL of 16 April 2014 on fluorinated greenhouse gases:

**This product contains fluorinated greenhouse gases in a hermetically sealed system.**

**If a leak in the sealed system is detected, the operator shall repair without undue delay.**

**For ThermoFlex24000 air-cooled chillers, after repair the operator shall ensure that the equipment is checked by a certified natural person within one month after the repair to verify that the repair has been effective.**

Refer to the F-Gas Declaration of Conformity for additional information.

## **Fluorierte Treib- hausgase**

Die folgende Information ist in diesen Unterlagen gemäß der VERORDNUNG (EU) Nr. 517/2014 DES EUROPÄISCHEN PARLAMENTS UND DES RATES vom 16. April 2014 über fluorierte Treibhausgase enthalten.

**Dieses Produkt enthält fluorierte Treibhausgase in einem hermetisch geschlossenen System.**

**Wird ein Leck im geschlossenen System entdeckt, muss der Anwender dieses unverzüglich reparieren.**

**Im Fall der luftgekühlten Umwälzkühler ThermoFlex24000 muss der Anwender nach der Reparatur sicherstellen, dass das Gerät innerhalb eines Monats nach der Reparatur von einer zertifizierten natürlichen Person daraufhin überprüft wird, ob die Reparatur wirksam war.**

## **Gaz à effet de serre fluorés**

Les informations suivantes sont fournies de façon à respecter la RÉGLEMENTATION (UE) N° 517/2014 DU PARLEMENT EUROPÉEN ET DU CONSEIL datée du 16 avril 2014 et portant sur les gaz à effet de serre fluorés :

**Ce produit contient des gaz à effet de serre fluorés intégrés à un système hermétiquement scellé.**

**Toute fuite détectée dans le système scellé doit être réparée immédiatement par l'opérateur.**

**Pour les refroidisseurs refroidis par air ThermoFlex24000, l'opérateur doit faire en sorte que l'équipement soit contrôlé par une personne physique agréée dans un délai d'un mois suivant la réparation, afin de s'assurer de l'efficacité de la réparation.**

## **Gases de efecto invernadero fluorados**

La siguiente información se incluye de acuerdo con la REGULACIÓN (UE) N°. 517/2014 DEL PARLAMENTO Y EL CONSEJO EUROPEO el 16 de abril de 2014 sobre gases de efecto invernadero fluorados:

**Este producto contiene gases de efecto invernadero en un sistema sellado herméticamente.**

**Si se detecta una fuga en el sistema sellado, el operador la reparará sin ninguna demora indebida.**

**En los enfriadores refrigerados por aire ThemoFlex24000, después de la reparación, el operador se asegurará de que una persona física certificada compruebe el equipo en un plazo de un mes después de la reparación para verificar que esta ha sido efectiva.**

## **Fluorerade växthusgaser**

Följande information finns med för att efterleva EUROPAPARLAMENTETS OCH RÅDETS FÖRORDNING (EU) nr. 517/2014 av den 16 april 2014 om fluorerade växthusgaser:

**Den här produkten innehåller fluorerade växthusgaser i ett hermetiskt förseglat system.**

**Om en läcka i det förseglade systemet identifieras, ska operatören reparera det utan dröjsmål.**

**För ThemoFlex24000 luftkylda kylare, ska operatören efter reparation tillse att utrustningen kontrolleras av en certifierad fysisk person inom en månad från reparationen, för att verifiera att reparationen har varit lyckad.**

## **Fluorovani gasovi sa efektom staklene bašte**

Sledeće informacije su uključene u skladu sa UREDBOM (EU) br. 517/2014 EVROPSKOG PARLAMENTA I SAVETA od 16. aprila 2014. o fluorovanim gasovima sa efektom staklene bašte:

**Ovaj proizvod sadrži fluorovane gasove sa efektom staklene bašte u hermetički zatvorenom sistemu.**

**Ako se otkrije curenje iz zatvorenog sistema, korisnik mora popraviti kvar bez nepotrebnog odlaganja.**

**Za ThemoFlex24000 rashlađivače hladene vazduhom, korisnik posle popravke mora osigurati da se oprema pregleda od strane ovlašćenog fizičkog lica u roku od mesec dana nakon popravke da bi se potvrdilo da je popravka bila efikasna.**

## **Fluorirani toplogredni plini**

Informacije v nadaljevanju so vključene za izpolnitev zahtev iz UREDBE (EU) ŠT. 517/2014 EVROPSKEGA PARLAMENTA IN SVETA z dne 16. aprila 2014 o fluoriranih toplogrednih plinih:

**Ta izdelek vsebuje fluorirane toplogredne pline v hermetično zaprtem sistemu.**

**Če se ugotovi uhajanje plinov iz zaprtega sistema, ga upravljavec brez nepotrebnega odlašanja popravi.**

**Po popravilu zračno hlajenih hladilnih agregatov ThemoFlex24000 upravljavec zagotovi, da opremo v enem mesecu po popravilu pregleda fizična oseba s spričevalom in preveri, ali je bilo popravilo uspešno.**

## **Fluorované skleníkové plyny**

Nasledujúce informácie sú tu uvedené z dôvodu súladu s NARIADENÍM (EÚ) Č. 517/2014 EURÓPSKEHO PARLAMENTU A RADY zo 16. apríla 2014 o fluorovaných skleníkových plynoch:

**Tento produkt obsahuje fluorované skleníkové plyny v hermeticky uzavretom systéme.**

**Ak dôjde v uzavretom systéme k únikom, operátor ho musí bez zbytočného oneskorenia opraviť.**

**Po oprave vzduchových chladičov ThermoFlex 24000 musí operátor zabezpečiť, aby zariadenie do jedného mesiaca od vykonania opravy skontrolovala osvedčená fyzická osoba, ktorá zhodnotí, či bola oprava efektívna.**

## **Gazele fluorurate cu efect de ser**

Următoarele informații sunt redactate în conformitate cu REGULAMENTUL (UE) NR. 517/2014 AL PARLAMENTULUI EUROPEAN I AL CONSILIULUI din 16 aprilie 2014 privind gazele fluorurate cu efect de seră:

**Acest produs conține gaze fluorurate cu efect de seră închise într-un sistem ermetic.**

**În cazul în care se detectează o scurgere la sistemul etanșat, operatorul trebuie să efectueze reparațiile necesare fără întârzieri nejustificate.**

**Pentru refrigeratoarele cu aer răcit ThemoFlex24000, după reparație, operatorii trebuie să se asigure că echipamentul va fi inspectat de către o persoană fizică certificată, la o lună de la reparație, pentru a verifica dacă aceasta s-a realizat în mod eficient.**

## **Gases fluorados com efeito de estufa**

As seguintes informações foram incluídas para efeitos de conformidade com o REGULAMENTO (UE) N.º 517/2014 DO PARLAMENTO E CONSELHO EUROPEUS de 16 de abril de 2014 relativo aos gases fluorados com efeito de estufa:

**Este produto contém gases fluorados com efeito de estufa num sistema hermeticamente fechado.**

**Em caso de deteção de fuga no sistema fechado, o operador deverá repará-la sem atraso injustificado.**

**No caso dos refrigeradores a ar ThermoFlex24000, após uma reparação, o operador deverá assegurar a inspeção do equipamento por parte de uma pessoa qualificada no prazo de um mês após a reparação, de forma a garantir a eficácia da mesma.**

## **Fluorowane gazy cieplarniane**

Poniższa informacja została zamieszczona w celu spełnienia wymagań określonych w ROZPORZĄDZENIU PARLAMENTU EUROPEJSKIEGO I RADY (UE) NR 517/2014 z 16 kwietnia 2014 roku w sprawie fluorowanych gazów cieplarnianych:

**Ten produkt zawiera fluorowane gazy cieplarniane w hermeticznym zamkniętym układzie.**

**W przypadku stwierdzenia wycieku z hermeticznym zamkniętego układu operator ma obowiązek dokonania naprawy urządzenia bez zbędnej zwłoki.**

**Po ewentualnej naprawie agregatów chłodniczych chłodzonych powietrzem ThermoFlex24000 operator ma obowiązek zapewnienia, aby urządzenie zostało skontrolowane przez certyfikowaną osobę fizyczną w ciągu miesiąca od naprawy w celu sprawdzenia, czy naprawa była skuteczna.**

## **Gefluoreerde broei- kassgasen**

De volgende informatie is toegevoegd om te voldoen aan VERORDENING (EU) Nr. 517/2014 VAN HET EUROPEES PARLEMENT EN DE RAAD van 16 april 2014 betreffende gefluoreerde broeikasgasen:

**Dit product bevat gefluoreerde broeikasgasen in een hermetisch afgesloten systeem.**

**Indien er een lek wordt gedetecteerd in het afgesloten systeem, dient de gebruiker deze te repareren zonder onnodige vertraging.**

**Bij de luchtgekoelde koelinstallaties ThermoFlex24000 dient de gebruiker er na de reparatie voor te zorgen dat de apparatuur wordt gecontroleerd door een gecertificeerde natuurlijke persoon, binnen een maand nadat de reparatie plaatsvindt, om te controleren of de reparatie is geslaagd.**



## **Gassijiet Fluworurati b'Effett ta' Serra**

L-informazzjonijiet hekk hi inluza biex tikkonforma mar-REGOLAMENT (UE) Nru 517/2014 TAL-PARLAMENT EWROPEW U TAL-KUNSILL tas-16 ta' April 2014 dwar gassijiet fluworurati b'effett ta' serra:

**Dan il-prodott fih gassijiet fluworurati b'effett ta' serra f'sistema ssiġillata ermetikament.**

**Jekk tinstab tnixxija fis-sistema ssiġillata, l-operatur għandu jsewwi mingħajr dewmien bla bżonn.**

**Għal chillers ThemoFlex 24000 imkessha bl-arja, wara t-tiswija, l-operatur għandu jiżgura li t-tagħmir jiġi vverifikat minn persuna fiżika ċcertifikata fi żmien xahar wara t-tiswija biex tivverifika li t-tiswija kienet effettiva.**

## **Fluor tas siltumn cefekta g zes**

Turpmāk norādītā informācija ir iekļauta, lai nodrošinātu atbilstību EIROPAS PARLAMENTA UN PADOMES REGULAI (ES) Nr. 517/2014 (2014. gada 16. aprīlis) par fluorētām siltumnīcefekta gāzēm.

**Šis izstrādājums satur fluorētas siltumnīcefekta gāzes hermētiski noslēgtā sistēmā.**

**Ja hermētiski noslēgtajā sistēmā tiek konstatēta noplūde, operators to salabo bez nepamatotas kavēšanās.**

**Pēc gaisa dzesētāju ThemoFlex24000 labošanas operators nodrošina, ka mēneša laikā no labošanas darbu veikšanas brīža sertificēta fiziskā persona pārbauda aprīkojumu, lai apstiprinātu, ka labošanas darbi bijuši sekmīgi.**

## **Fluorintos šiltnamio efekt sukelianios dujos**

Toliau pateikta informācija yra įtraukta, kad būtų laikomasi 2014 m. balandžio 16 d. EUROPOS PARLAMENTO IR TARYBOS REGLAMENTO (ES) Nr. 517/2014 dėl fluorintų šiltnamio efektą sukeliančių dujų.

**Hermetiškai sandarioje šio produkto sistemoje yra fluorintų šiltnamio efektą sukeliančių dujų.**

**Jeigu aptinkamas sandario sistemos nuotėkis, operatoriui nedelsdamas turi jį suremontuoti.**

**Jeigu naudojami „ThemoFlex24000“ oru aušinami aušintuvai, po remonto darbų operatoriui užtikrina, kad įrangą patikrins sertifikuotas fizinis asmuo per vieną mėnesį nuo remonto darbų, kad būtų patikrinta, jog remonto darbai buvo veiksmingi.**

## **Gas fluorurati a effetto serra**

Si includono le seguenti informazioni in conformità con il REGOLAMENTO (UE) N. 517/2014 DEL PARLAMENTO EUROPEO E DEL CONSIGLIO del 16 aprile 2014 sui gas fluorurati a effetto serra:

**Il presente prodotto contiene gas fluorurati a effetto serra all'interno di un sistema a chiusura ermetica.**

**In caso di perdita del sistema a chiusura ermetica, l'operatore dovrà prontamente provvedere alla riparazione.**

**Per i refrigeratori ad aria ThemoFlex24000, dopo la riparazione l'operatore dovrà assicurarsi di far controllare l'apparecchiatura da una persona fisica certificata entro un mese dalla riparazione al fine di verificare l'efficacia della stessa.**

## **Fluortartalmú üvegházhatású gázok**

A következő tájékoztatás az EURÓPAI PARLAMENT ÉS A TANÁCS (EU) 517/2014. SZÁMÚ, 2014. április 16-i, a fluortartalmú üvegházhatású gázokkal kapcsolatos RENDELETÉBEN előírtak teljesítése érdekében került a dokumentumba:

**A termék fluortartalmú üvegházhatású gázokat tartalmaz, hermetikusan zárt rendszerben.**

**Ha a zárt rendszerben szivárgás jelentkezik, az üzemeltető köteles a lehető leghamarabb megszüntetni azt.**

**A ThemoFlex24000 léghűtőkön végzett javítás után az üzemeltető köteles a javítástól számított egy hónapon belül megfelelő tanúsítvánnyal rendelkező természetes személlyel ellenőriztetni, hogy a javítás hatásos volt-e.**

## **Fluorirani stakleni ki plinovi**

Informacije navedene u nastavku u skladu su s UREDBOM (EU) br. 517/2014 EUROPSKOG PARLAMENTA I VIJEĆA od 16. travnja 2014. o fluoriranim stakleničkim plinovima:

**Ovaj proizvod sadrži fluorirane stakleničke plinove u hermetički zatvorenom sustavu.**

**Ako se u hermetički zatvorenom sustavu otkrije propuštanje, operater ga mora popraviti bez nepotrebne odgode.**

**Za zrakom hladene rashladnike vode ThemoFlex24000, operater nakon popravka osigurava da opremu provjeri certificirana fizička osoba u roku od mjesec dana od popravka kako bi potvrdila uspješnost popravka.**

## **Gáis Cheaptha Teasa Fhluairínithe**

Áirítear an fhaisnéis a leanas chun RIALACHÁN (AE) Uimh. 517/2014 Ó PHARLAIMINT NA hEORPA AGUS ÓN gCOMHAIRLE an 16 Aibreán 2014 maidir le gáis cheaptha teasa fhlúairínithe a chomhlíonadh:

**Cuimsíonn an táirgeadh seo gáis cheaptha teasa fhlúairínithe i gcóras atá séalaithe go heirméiteach.**

**Má bhraitear sceitheadh sa chóras séalaithe, déanfaidh an t-oibreoir deisiúchán gan mhoill.**

**I gcás fuaraitheoirí aerfhuaraithe ThermoFlex24000, tar éis an deisiúcháin áiritheoidh an t-oibreoir go ndéanfaidh duine nádúrtha deimhnithe an trealamh a sheiceáil laistigh d'aon mhí tar éis an deisiúcháin le deimhniú go raibh an deisiúchán éifeachtach.**

## **Fluoratut kasvihuonekaasut**

Seuraavat tiedot on lisätty, jotta noudatetaan 16. päivänä huhtikuuta 2014 fluoratuista kasvihuonekaasuista annettua EUROOPAN PARLAMENTIN JA NEUVOSTON ASETUSTA (EU) N:o 517/2014:

**Tämä tuote sisältää fluorattuja kasvihuonekaasuja hermeettisesti tiivistetyssä järjestelmässä.**

**Jos tiivistetyssä järjestelmässä havaitaan vuoto, käyttäjän on korjattava se viipymättä.**

**Ilmajäähdytteisten ThermoFlex24000-jäähdyttimien korjaamisen jälkeen käyttäjän on varmistettava, että valtuutettu luonnollinen henkilö varmistaa korjauksen tarkistamalla laitteen kuukauden kuluessa korjauksesta.**

## **Fluoritud kasvuhoo- negaasid**

Alljärgnev teave on lisatud, et järgida EUROOPA PARLAMENDI JA NÕUKOGU MÄÄRUST NR 517/2014 16. aprill 2014 fluoritud kasvuhoo-  
negaaside kohta.

**See toode sisaldab hermeetiliselt suletud süsteemis fluoritud kasvuhoo-  
negaase.**

**Lekke tuvastamise korral hermeetiliselt suletud süsteemis peab operaator viivitamatult lekke remontima.**

**Õhkjahutusega jahutite ThermoFlex24000 korral peab operaator pärast remonti tagama, et seadmeid kontrolliks sertifitseeritud füüsiline isik ühe kuu jooksul pärast remonditööd, et kinnitada remonditöö tulemuslikkus.**

**μ π**

Οι ακόλουθες πληροφορίες περιλαμβάνονται για λόγους συμμόρφωσης με τον ΚΑΝΟΝΙΣΜΟ (ΕΕ) αριθ. 517/2014 ΤΟΥ ΕΥΡΩΠΑΪΚΟΥ ΚΟΙΝΟΒΟΥΛΙΟΥ ΚΑΙ ΤΟΥ ΣΥΜΒΟΥΛΙΟΥ της 16ης Απριλίου 2014 για τα φθοριούχα αέρια του θερμοκηπίου:

**Το παρόν προϊόν περιέχει φθοριούχα αέρια του θερμοκηπίου σε ερμητικά σφραγισμένο σύστημα.**

**Σε περίπτωση ανίχνευσης διαρροής στο σφραγισμένο σύστημα, ο χειριστής προβαίνει σε επιδιόρθωση χωρίς αδικαιολόγητη καθυστέρηση.**

**Για τους αερόψυκτους ψύκτες ThemoFlex24000, ο χειριστής διασφαλίζει ότι ο εξοπλισμός ελέγχεται από πιστοποιημένο φυσικό πρόσωπο εντός ενός μήνα μετά την επιδιόρθωση, ώστε να επιβεβαιώνεται ότι η επιδιόρθωση ήταν αποτελεσματική.**

## **Fluorholdige drivhusgasser**

Nedenstående oplysninger er medtaget som dokumentation for overholdelse af EUROPA-PARLAMENTET OG RÅDETS FORORDNING (EU) nr. 517/2014 af 16. april 2014 om fluorholdige drivhusgasser:

**Dette produkt indeholder fluorholdige drivhusgasser i et hermetisk forsejlet system.**

**Hvis der konstateres en lækage i det forsejlede system, skal operatøren hurtigst muligt reparere lækagen.**

**Hvad angår luftkølede luftkølere af typen ThemoFlex 24000, skal operatøren sørge for, at udstyret inden for én måned efter reparationen kontrolleres af en fagmand, der kan bekræfte, at der er tale om en effektiv reparation.**

## **Fluorované skleníkové plyny**

Následující informace jsou zahrnuty pro dodržení PŘEDPISU (EU) č. 517/2014 EVROPSKÉHO PARLAMENTU A RADY ze dne 16. dubna 2014 o fluorovaných skleníkových plynech:

**Tento výrobek obsahuje fluorované skleníkové plyny v hermeticky utěsněném systému.**

**Pokud je v systému zjištěn únik, provozovatel ho musí okamžitě opravit.**

**U vzduchem chlazených chladičů ThemoFlex24000 musí provozovatel po opravě zajistit, aby bylo zařízení do jednoho měsíce po opravě zkontrolováno fyzickou osobou s osvědčením, aby se ověřilo, že oprava byla účinná.**



## **Флуорсъдържащи парникови газове**

Следната информация е включена в съответствие с РЕГЛАМЕНТ (ЕС) № 517/2014 НА ЕВРОПЕЙСКИЯ ПАРЛАМЕНТ И НА СЪВЕТА от 16 април 2014 г. за флуорсъдържащите парникови газове:

**Този продукт съдържа флуорсъдържащи парникови газове в херметично затворена система.**

**Ако в затворената система бъде засечен теч, операторът трябва незабавно да извърши ремонт.**

**При ремонт на чилъри с въздушно охлаждане ThermoFlex24000 операторът трябва да осигури проверка на оборудването от сертифицирано лице в рамките на един месец след ремонта като гаранция, че ремонтът е ефективен.**

**Declaration of conformity with Article 14 of Regulation (EU) No 517/2014 of the European Parliament and of the Council**

We, Thermo Fisher Scientific (Asheville) LLC, F-Gas Portal Registration Number 23643, declare under our sole responsibility that when placing on the market pre-charged equipment, which we import to or manufacture in the Union, the hydrofluorocarbons contained in that equipment are accounted for within the quota system referred to in Chapter IV of Regulation (EU) No 517/2014 as:

We hold authorisation(s) issued in accordance with Article 18(2) of Regulation (EU) No 517/2014 and registered in the registry referred to in Article 17 of that Regulation, at the time of release for free circulation to use the quota of a producer or importer of hydrofluorocarbons subject to Article 15 of Regulation (EU) No 517/2014 that cover(s) the quantity of hydrofluorocarbons contained in the equipment.

The hydrofluorocarbons contained in the equipment have been placed on the market in the Union, subsequently exported and charged into the equipment outside the Union, and the undertaking that placed the hydrofluorocarbons on the market made a declaration stating that the quantity of hydrofluorocarbons has been or will be reported as placed on the market in the Union and that it has not been and will not be reported as direct supply for export in the meaning of Article 15(2)(c) of Regulation (EU) No 517/2014 pursuant to Article 19 of Regulation (EU) No 517/2014 and Section 5C of the Annex to Commission Implementing Regulation (EU) No 1191/2014.

January 1, 2017

\_\_\_\_\_  
Date

Mark Pearson, Director Global Regulatory Affairs

\_\_\_\_\_  
[name and position of legal representative]



\_\_\_\_\_  
[signature of legal representative]

Manufacturer:

Thermo Fisher Scientific (Asheville) LLC  
275 Aiken Road  
Asheville, NC 28804  
U.S.A.

EU Only Representative:

Thermo Electron LED GmbH  
Robert-Bosch-Strasse 1  
D-63505 Langenselbold  
Germany  
**VAT ID Number: DE 812 403 137**

## Section 2 General Information

### Description

The Thermo Scientific ThermoFlex™ recirculating chillers are designed to provide a continuous supply of fluid at a constant temperature and flow rate. The chiller consists of an air-cooled or water-cooled refrigeration system, heat exchanger, recirculating pump, reservoir and a microprocessor controller.

### Specifications

	ThermoFlex900	ThermoFlex1400	ThermoFlex2500
<b>Standard Chiller Process Fluid Temperature/Setpoint Range</b>	+5°C to +40°C +41°F to +104°F	+5°C to +40°C +41°F to +104°F	+5°C to +40°C +41°F to +104°F
<b>High-Temperature Chiller Process Fluid Temperature/Setpoint Range</b>	Not Available Not Available	+5°C to +90°C +41°F to +194°F	+5°C to +90°C +41°F to +194°F
<b>Ambient Temperature Range All Chillers</b>	+ 10°C to +40°C + 50°F to +104°F	+10°C to +40°C +50°F to +104°F	+10°C to +40°C +50°F to +104°F
<b>Temperature Stability</b>	±0.1°C	±0.1°C	±0.1°C
<b>Cooling Capacity at 20°C</b> 60 Hz 50 Hz	900 W (3074 BTU) 750 W (2561 BTU)	1400 W (4781 BTU) 1170 W (3996 BTU)	2500 W (8538 BTU)* 2200W(7513BTU)*
*To meet this specification, the ThermoFlex2500 air-cooled chillers require the fan to be operating in the high-speed mode, see Section 3.			
<b>Heater Size</b> 208V/230V	Not Available	1.0kW/1.2kW or 2.3kW/2.8kW	2.3kW/2.8kW
<b>Refrigerant</b>	R134A	R134A	R134A
<b>Reservoir Volume</b> Gallons Liters	1.9 7.2	1.9 7.2	1.9 7.2
<b>Footprint or Dimensions (H x W x D)</b> Inches Centimeters	27.3 x 14.2 x 24.6 69.2 x 36.0 x 62.4	27.3 x 14.2 x 24.6 69.2 x 36.0 x 62.4	29.0 x 17.2 x 26.5 73.6 x 43.6 x 67.3
<b>Weight P2 Pump (empty)</b> lb kg	130.5 59.2	130.5 59.2	175.5 79.6
<b>Pumping Capacity</b>			
P 1/MD 1 - Positive Displacement 60 Hz 50 Hz		2.1 gpm @ 60 psig (7.9 lpm @ 4.1 bar) 1.7 gpm @ 60 psig (6.4 lpm @ 4.1 bar)	
P 2/MD 2 - Positive Displacement 60 Hz 50 Hz		4.0 gpm @ 60 psig (15.1 lpm @ 4.1 bar) 3.3 gpm @ 60 psig (12.5 lpm @ 4.1 bar)	
T 0 - Turbine 60 Hz* 50 Hz*		2.0 gpm @ 60 psid (7.6 lpm @ 4.1 bar) 1.3 gpm @ 60 psid (4.9 lpm @ 4.1 bar)	
T 1 - Turbine 60 Hz* 50 Hz*		3.5 gpm @ 60 psid (13.3 lpm @ 4.1 bar) 2.5 gpm @ 60 psid (9.5 lpm @ 4.1 bar)	

\* Pumping capacity pressure values for turbine pumps are differential pressures between the inlet and the outlet of the chiller.

- Cooling capacity based on P 2 pumps with no backpressure. Heat input from the pump will result in a reduction in cooling capacity. The cooling capacity reduction will vary based on the pump chosen as well as pump backpressure and flow.
- Specifications obtained at sea level using water as the recirculating fluid, at a 20°C process setpoint, 25°C ambient condition, at nominal operating voltage. Other fluids, fluid temperatures, ambient temperatures, altitude or operating voltages will affect performance. See Section 3.
- Additional dimensions are at the end of this section, add 1/8" (3 mm) to height for SEMI.
- Add 5 pounds (2 kilograms) for global voltage chillers.
- Thermo Fisher Scientific reserves the right to change specifications without notice.

# Specifications

	ThermoFlex3500	ThermoFlex5000
<b>Standard Chiller Process Fluid Temperature/Setpoint Range</b>	+5°C to +40°C +41°F to +104°F	+5°C to +40°C +41°F to +104°F
<b>High-Temperature Chiller Process Fluid Temperature/Setpoint Range</b>	+5°C to +90°C +41°F to +194°F	+5°C to +90°C +41°F to +194°F
<b>Ambient Temperature Range All Chillers</b>	+10°C to +40°C +50°F to +104°F	+10°C to +40°C +50°F to +104°F
<b>Temperature Stability</b>	±0.1°C	±0.1°C
<b>Cooling Capacity at 20°C</b>		
60 Hz	3500 W (11953 BTU)	5000 W (17076 BTU)
50 Hz	3050 W (10416 BTU)	4400 W (15027 BTU)
<b>Heater Size 208V/230V</b>	2.3kW/2.8kW	2.3kW/2.8kW
<b>Refrigerant</b>	R407C	R407C
<b>Reservoir Volume</b>		
Gallons	1.9	1.9
Liters	7.2	7.2
<b>Footprint or Dimensions (H x W x D)</b>		
Inches	38.9 x 19.3 x 30.9	38.9 x 19.3 x 30.9
Centimeters	98.7 x 48.8 x 78.4	98.7 x 48.8 x 78.4
<b>Weight P 1/ P 2/P 3/P 4 (empty)</b>		
lb	264/264/270/303	NA/264/270/303
kg	120/120/123/138	NA/120/123/138
<b>Pumping Capacity</b>		
P1/MD 1 - Positive Displacement		
60 Hz	2.1 gpm @ 60 psig (7.9 lpm @ 4.1 bar)	Not Available
50 Hz	1.7 gpm @ 60 psig (6.4 lpm @ 4.1 bar)	Not Available
P2/MD 2 - Positive Displacement		
60 Hz	4.0 gpm @ 60 psig (15.1 lpm @ 4.1 bar)	4.0 gpm @ 60 psig (15.1 lpm @ 4.1 bar)
50 Hz	3.3 gpm @ 60 psig (12.5 lpm @ 4.1 bar)	3.3 gpm @ 60 psig (12.5 lpm @ 4.1 bar)
T 1 - Turbine		
60 Hz*	3.5 gpm @ 60 psid (13.3 lpm @ 4.1 bar)	3.5 gpm @ 60 psid (13.3 lpm @ 4.1 bar)
50 Hz*	2.5 gpm @ 60 psid (9.5 lpm @ 4.1 bar)	2.5 gpm @ 60 psid (9.5 lpm @ 4.1 bar)
P 3 - Centrifugal Pump		
60 Hz*	10 gpm @ 32 psid (37.9 lpm @ 2.2 bar)	10 gpm @ 32 psid (37.9 lpm @ 2.2 bar)
50 Hz*	10 gpm @ 20 psid (37.9 lpm @ 1.4 bar)	10 gpm @ 20 psid (37.9 lpm @ 1.4 bar)
P 4 - Centrifugal Pump		
60 Hz*	15 gpm @ 57 psid (56.8 lpm @ 3.9 bar)	15 gpm @ 57 psid (56.8 lpm @ 3.9 bar)
50 Hz*	15 gpm @ 34 psid (56.8 lpm @ 2.3 bar)	15 gpm @ 34 psid (56.8 lpm @ 2.3 bar)

\* Pumping capacity pressure values for turbine and centrifugal pumps are differential pressures between the inlet and the outlet of the chiller.

- Cooling capacity based on P2 pumps with no backpressure. Heat input from the pump will result in a reduction in cooling capacity. The cooling capacity reduction will vary based on the pump chosen as well as pump backpressure and flow.
- Specifications obtained at sea level using water as the recirculating fluid, at a 20°C process setpoint, 25°C ambient condition, at nominal operating voltage. Other fluids, fluid temperatures, ambient temperatures, altitude or operating voltages will affect performance. See Section 3.
- Additional dimensions are at the end of this section, add 1/8" (3 cm) to height for SEMI.
- Add 30 pounds (14 kilograms) for global voltage chillers.
- Thermo Fisher Scientific reserves the right to change specifications without notice.

## Specifications

	ThermoFlex7500	ThermoFlex10000
<b>Standard Chiller Process Fluid Temperature/Setpoint Range</b>	+5°C to +40°C +41°F to +104°F	+5°C to +40°C +41°F to +104°F
<b>High-Temperature Chiller Process Fluid Temperature/Setpoint Range</b>	+5°C to +90°C +41°F to +194°F	+5°C to +90°C +41°F to +194°F
<b>Ambient Temperature Range All Chillers</b>	+10°C to +40°C +50°F to +104°F	+10°C to +40°C +50°F to +104°F
<b>Temperature Stability</b>	± 0.1°C	± 0.1°C
<b>Cooling Capacity at 20°C</b>		
60 Hz	7500 W (25575 BTU)	10000 W (34100 BTU)
50 Hz	6425 W (21910 BTU)	8500 W (28985 BTU)
<b>Heater Size</b>	5.0kW at 208V/6.1kW at 230V 4.6kW at 400V/6.1kW at 460V	5.0kW at 208V/6.1kW at 230V 4.6kW at 400V/6.1kW at 460V
<b>Refrigerant</b>	R407C	R407C
<b>Reservoir Volume</b>		
Gallons	4.75	4.75
Liters	17.9	17.9
<b>Footprint or Dimensions (H x W x D)</b>		
Air-Cooled Inches	52.3 x 25.2 x 33.8	52.3 x 25.2 x 33.8
Centimeters	132.7 x 63.9 x 85.6	132.7 x 63.9 x 85.6
Water-Cooled Inches	45.9 x 25.2 x 33.8	45.9 x 25.2 x 33.8
Centimeters	116.6 x 63.9 x 85.6	116.6 x 63.9 x 85.6
<b>Weight P2/P3/P5 (empty)</b>		
Air-Cooled lb	356/372.5/405.5	356/372.5/405.5
kg	161.5/169/184	161.5/169/184
Water-Cooled lb	315/331.5/364.5	315/331.5/364.5
kg	143/150/165	143/150/165
<b>Pumping Capacity</b>		
P2/MD2 - Positive Displacement 60 Hz	4.0 gpm @ 60 psig (15.1 lpm @ 4.1 bar)	4.0 gpm @ 60 psig (15.1 lpm @ 4.1 bar)
50 Hz	3.3 gpm @ 60 psig (12.5 lpm @ 4.1 bar)	3.3 gpm @ 60 psig (12.5 lpm @ 4.1 bar)
P3 - Centrifugal Pump 60 Hz*	10 gpm @ 32 psid (37.9 lpm @ 2.2 bar)	10 gpm @ 32 psid (37.9 lpm @ 2.2 bar)
50 Hz*	10 gpm @ 20 psid (37.9 lpm @ 1.4 bar)	10 gpm @ 20 psid (37.9 lpm @ 1.4 bar)
P5 - Centrifugal Pump 60 Hz*	20 gpm @ 60 psid (75.7 lpm @ 4.1 bar)	20 gpm @ 60 psid (75.7 lpm @ 4.1 bar)
50 Hz*	20 gpm @ 35 psid (75.7 lpm @ 2.4 bar)	20 gpm @ 35 psid (75.7 lpm @ 2.4 bar)
T5 - Turbine Pump 60 Hz*	7.3 gpm @ 60 psid (27.6 lpm @ 4.1 bar)	7.3 gpm @ 60 psid (27.6 lpm @ 4.1 bar)
50 Hz*	6.2 gpm @ 60 psid (23.5 lpm @ 4.1 bar)	6.2 gpm @ 60 psid (23.5 lpm @ 4.1 bar)

\* Pumping capacity pressure values for centrifugal and turbine pumps are differential pressures between the inlet and the outlet of the chiller. P 5 pumping capacity in high temperature chillers is slightly lower, see P 5 Pumping Capacity curves in this Section.

- Cooling capacity based on P 2 pumps with no backpressure. Heat input from the pump will result in a reduction in cooling capacity. The cooling capacity reduction will vary based on the pump chosen as well as pump backpressure and flow.
- Specifications obtained at sea level using water as the recirculating fluid, at a 20°C process setpoint, 25°C ambient condition, at nominal operating voltage. Other fluids, fluid temperatures, ambient temperatures, altitude or operating voltages will affect performance. See Section 3.
- Additional dimensions are at the end of this section.
- For global voltage chillers with a P 2 pump add 30 pounds (14 kilograms). Add 10 pounds (4.5 kilograms) for chillers with a P 3 or P 5 pump.
- Thermo Fisher Scientific reserves the right to change specifications without notice.



# Specifications

## ThermoFlex24000

<b>Standard Chiller Process Fluid Temperature/Setpoint Range</b>	-5°C to +90°C +23°F to +194°F
<b>Ambient Temperature Range</b>	+10°C to +40°C +50°F to +104°F
<b>Temperature Stability</b>	± 0.1°C
<b>Cooling Capacity at 20°C</b>	
60 Hz	24000 W (81964 BTU)
50 Hz	21000 W (71719 BTU)
<b>Refrigerant</b>	R407C
<b>Reservoir Volume</b>	
Gallons	4.75
Liters	17.9
<b>Footprint or Dimensions (H x W x D)</b>	
Air-Cooled Inches	58.6 x 46.5 x 31.5
Centimeters	148.9 x 118.1 x 80.0
Water-Cooled Inches	49.4 x 46.5 x 31.5
Centimeters	125.5 x 118.1 x 80.0
<b>Weight P3 (empty)</b>	
Air-Cooled lb	650
kg	294.8
Water-Cooled lb	510
kg	231.3
<b>Pumping Capacity</b>	
P 3 - Centrifugal Pump 60 Hz*	10 gpm @ 32psid (37.9 lpm @ 2.2 bar)
50 Hz*	10 gpm @ 20 psid (37.9 lpm @ 1.4 bar)
P 5 - Centrifugal Pump 60 Hz*	20 gpm @ 60 psid (75.7 lpm @ 4.1 bar)
50 Hz*	20 gpm @ 35 psid (75.7 lpm @ 2.4 bar)
T9 - Turbine Pump 60 Hz*	27 gpm @ 50 psid (102.2 lpm @ 3.4 bar)
50 Hz*	22 gpm @ 50 psid (83.2 lpm @ 3.4 bar)

\* Pressure values are differential pressures between the inlet and the outlet of the chiller.

- Cooling capacity based on P 3 pumps set to 10 gpm. Heat input from the pump will result in a reduction in cooling capacity. The cooling capacity reduction will vary based on the pump chosen as well as pump backpressure and flow.
- Specifications obtained at sea level using water as the recirculating fluid, at a 20°C process setpoint, 25°C ambient condition, at nominal operating voltage. Other fluids, fluid temperatures, ambient temperatures, altitude or operating voltages will affect performance. See Section 3.
- Additional dimensions are at the end of this section.
- Thermo Fisher Scientific reserves the right to change specifications without notice.

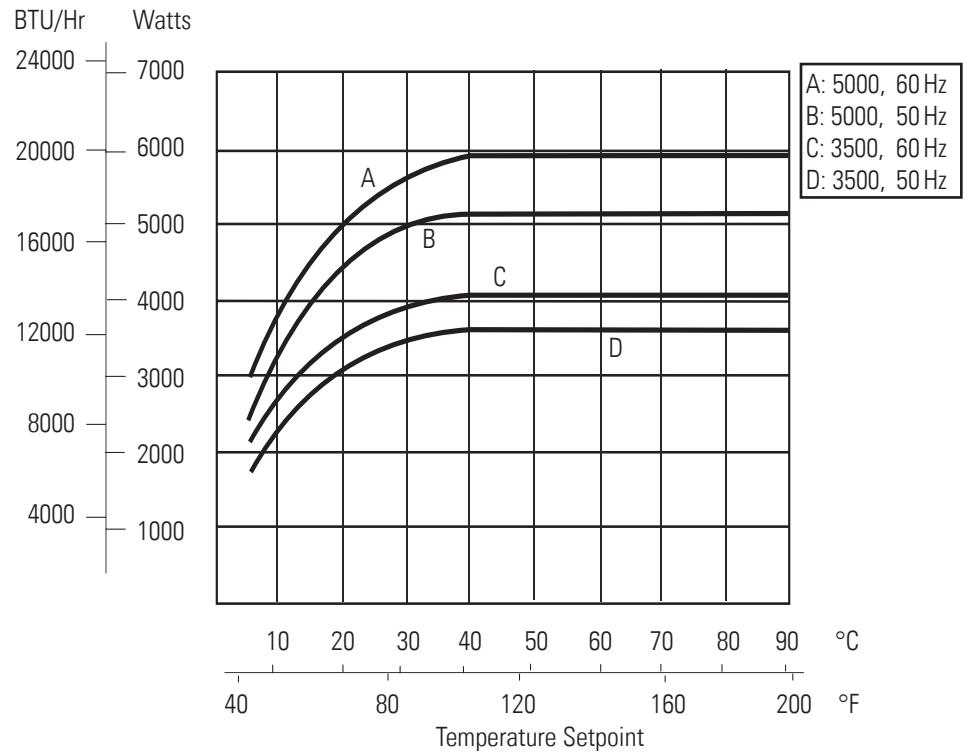
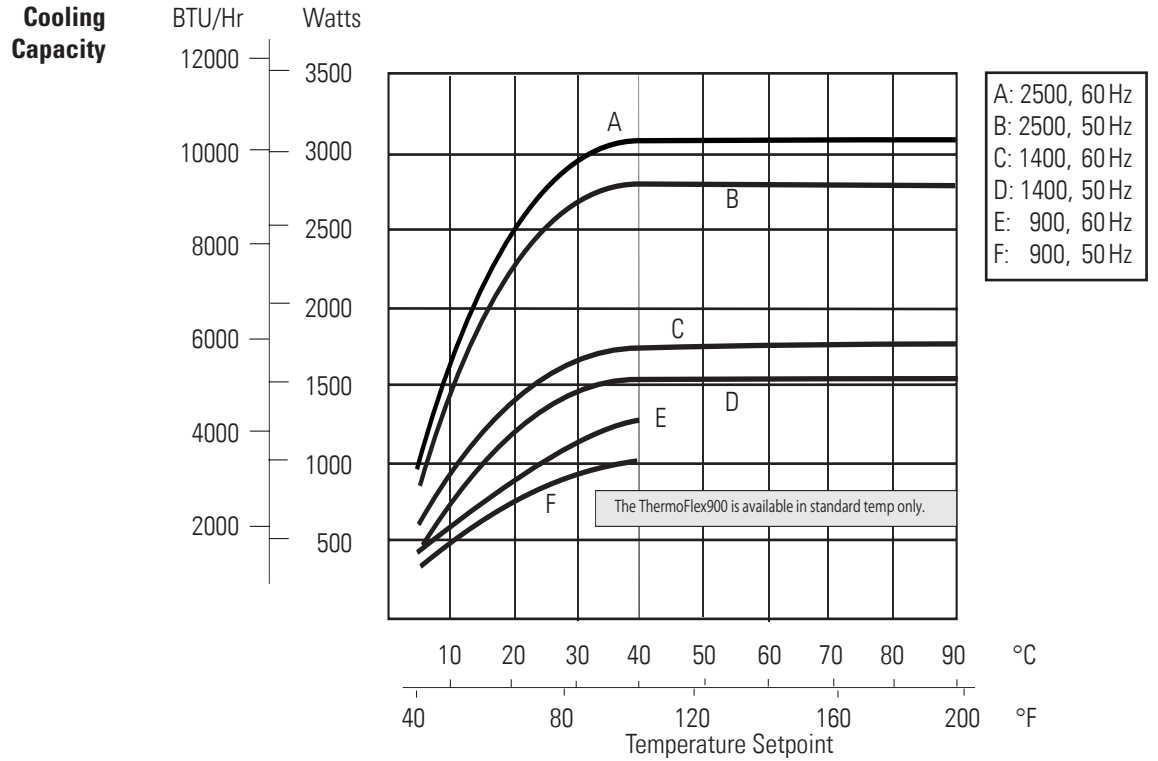

- Specifications obtained at sea level using water as the recirculating fluid, at a 20°C process setpoint, 25°C ambient condition, at nominal operating voltage, on chillers with P2 pumps with no back pressure. Other fluids, fluid temperatures, ambient temperatures, altitude, operating voltages or pumps will affect performance. See Section 3.
- Thermo Fisher Scientific reserves the right to change specifications without notice.

**Cooling Capacity**

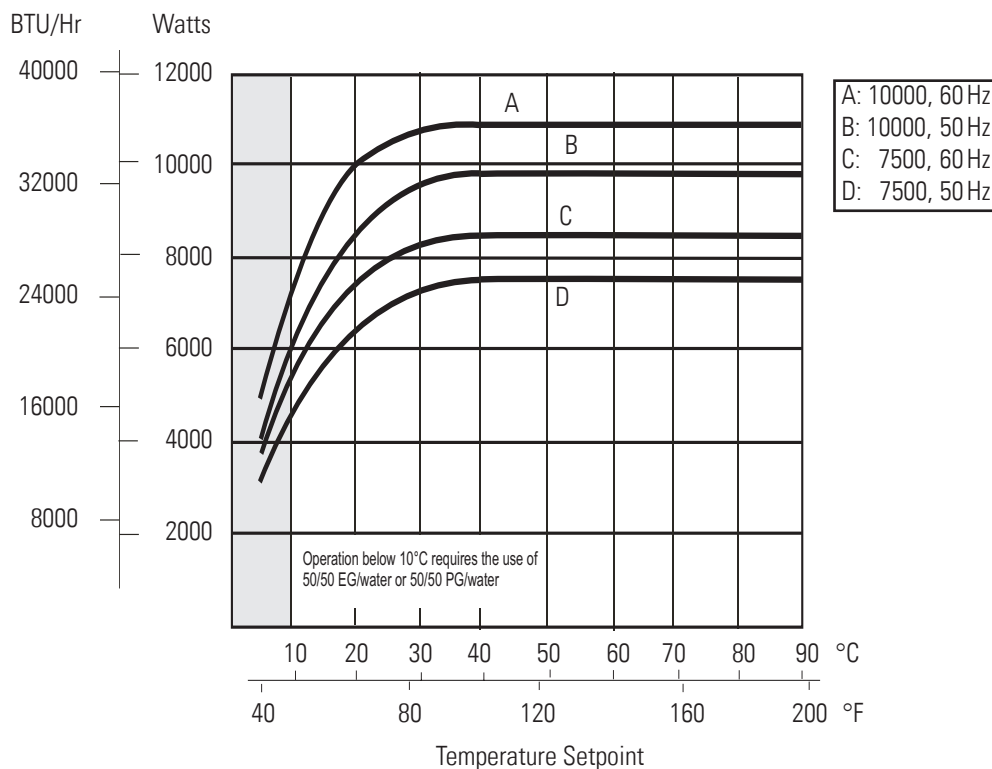

- Specifications obtained at sea level using water as the recirculating fluid, at a 20°C process setpoint, 25°C ambient condition, at nominal operating voltage, on chillers with P2 pumps with no back pressure. Other fluids, fluid temperatures, ambient temperatures, altitude, operating voltages or pumps will affect performance. See Section 3.
- Chillers require the use of 50/50 EG/water or 50/50 PG/water below 10°C process temperature to prevent freezing/glazing of the plate exchanger.
- Thermo Fisher Scientific reserves the right to change specifications without notice.

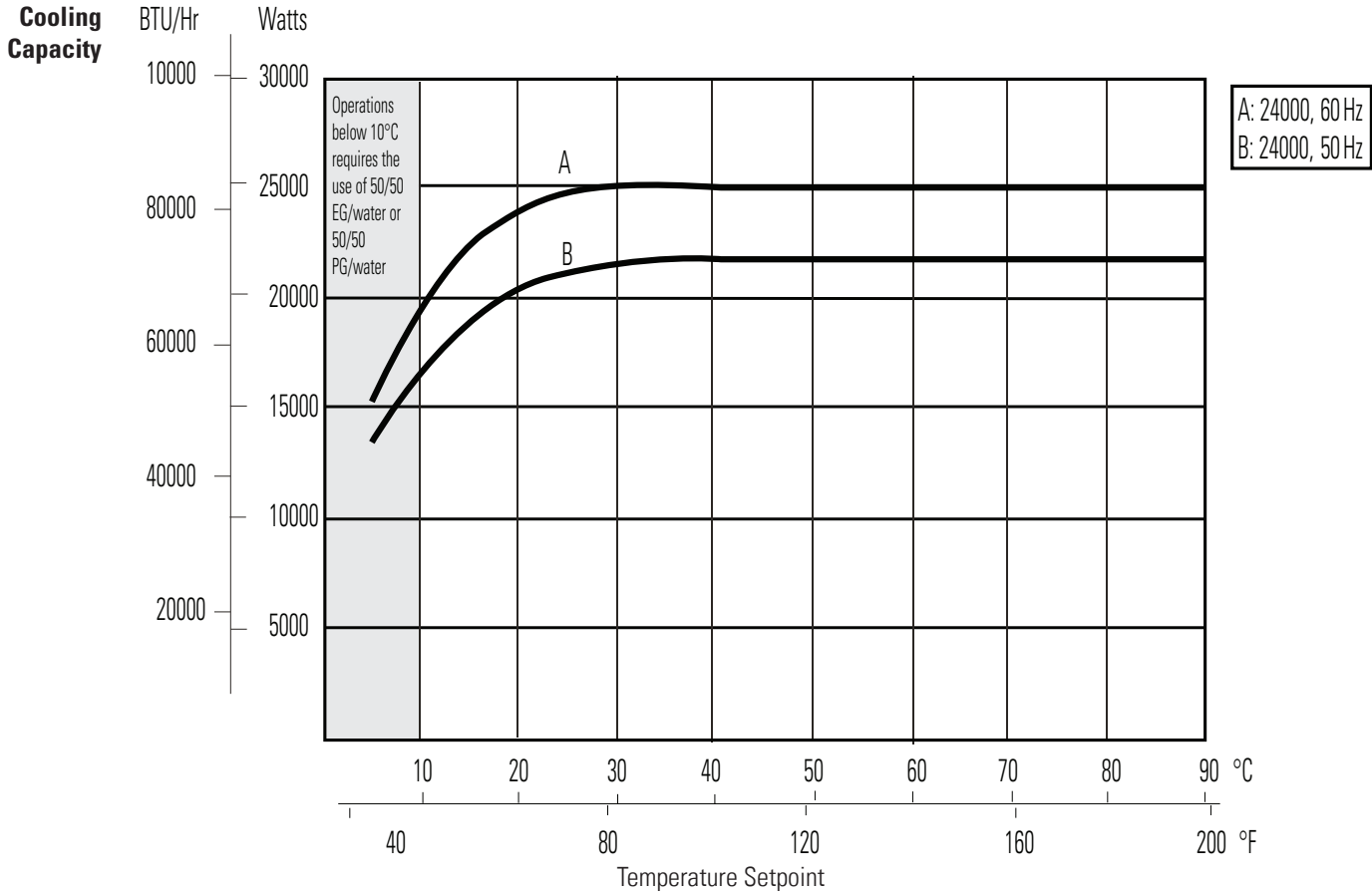

- Specifications obtained at sea level using water as the recirculating fluid, at a 20°C process setpoint, 25°C ambient condition, at nominal operating voltage, on chillers with P2 pumps with no back pressure (P3 pumps set to 10 gpm for ThermoFlex15000 to 24000). Other fluids, fluid temperatures, ambient temperatures, altitude, operating voltages or pumps will affect performance. See Section 3.
- Chillers require the use of 50/50 EG/water or 50/50 PG/water below 10°C process temperature to prevent freezing/glazing of the plate exchanger.
- Thermo Fisher Scientific reserves the right to change specifications without notice.

**Pumping Capacity  
Positive Displacement Pump P1/P2  
Magnetic Drive Pumps MD1/MD2**

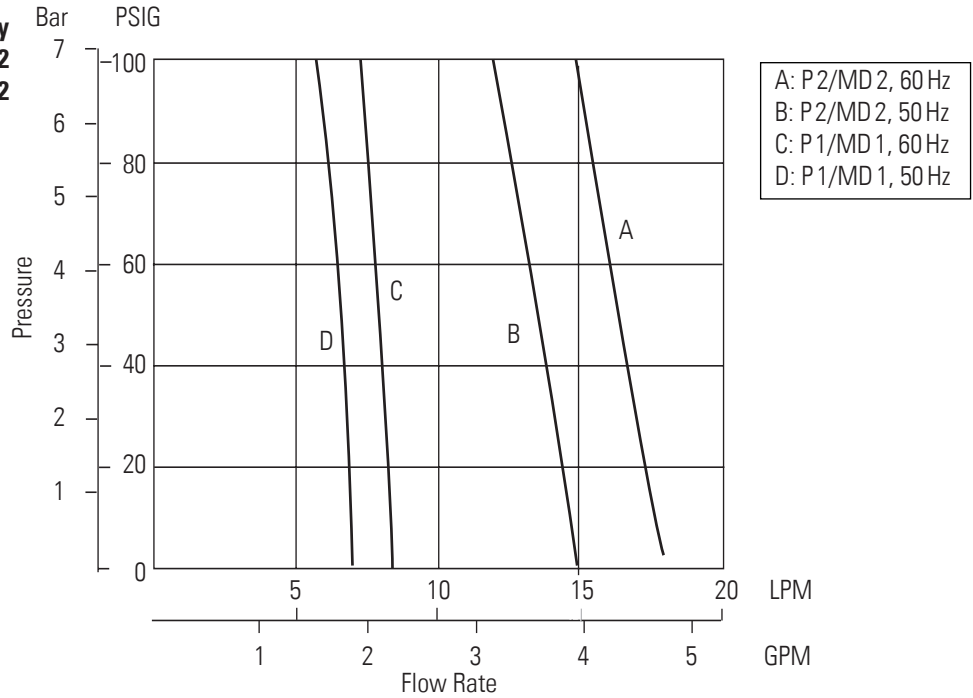

**Pumping Capacity  
Turbine Pump T1/T5**

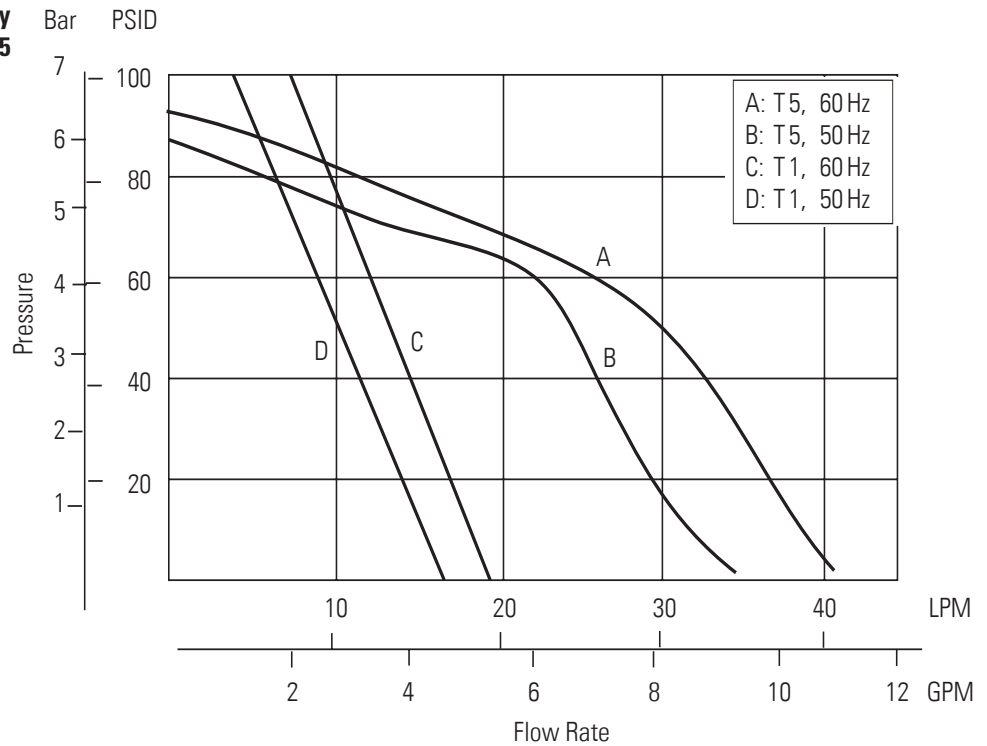

- Pump curves are nominal values. Pressure values for turbine pumps are differential pressures between the inlet and the outlet of the chiller.
- Pump performance results were obtained with no restrictions on the return to the system or with any options installed. For example, utilizing the DI option will result in a 0.5 gpm flow reduction.
- Specifications obtained at sea level using water as the recirculating fluid, at a 20°C process setpoint, 25°C ambient condition, at nominal operating voltage. Other fluids, fluid temperatures, ambient temperatures, altitude or operating voltages will affect performance. See Section 3.
- Thermo Fisher Scientific reserves the right to change specifications without notice.



**Pumping Capacity  
Centrifugal Pump P3/P4**

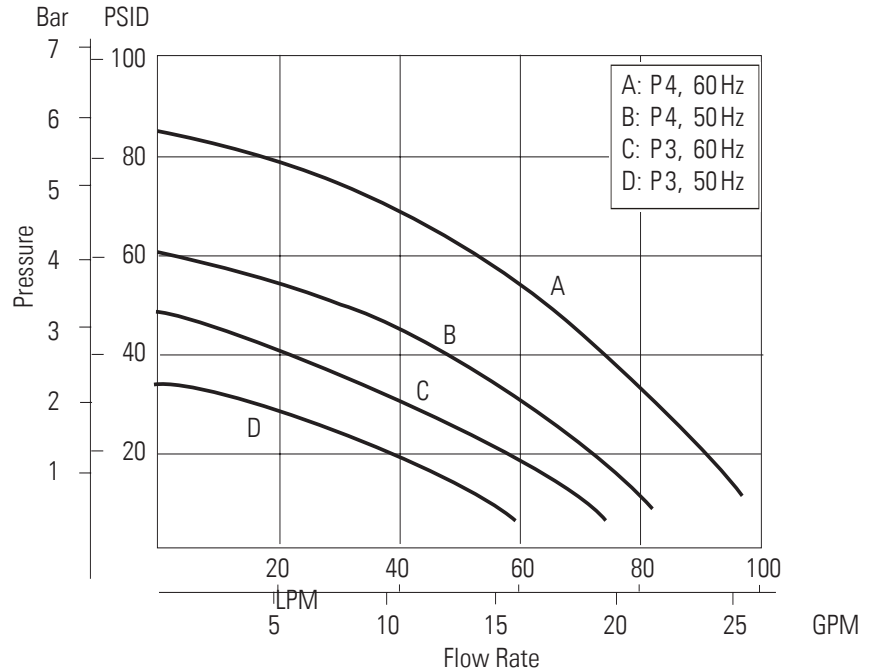

**Pumping Capacity  
Centrifugal Pump P5**

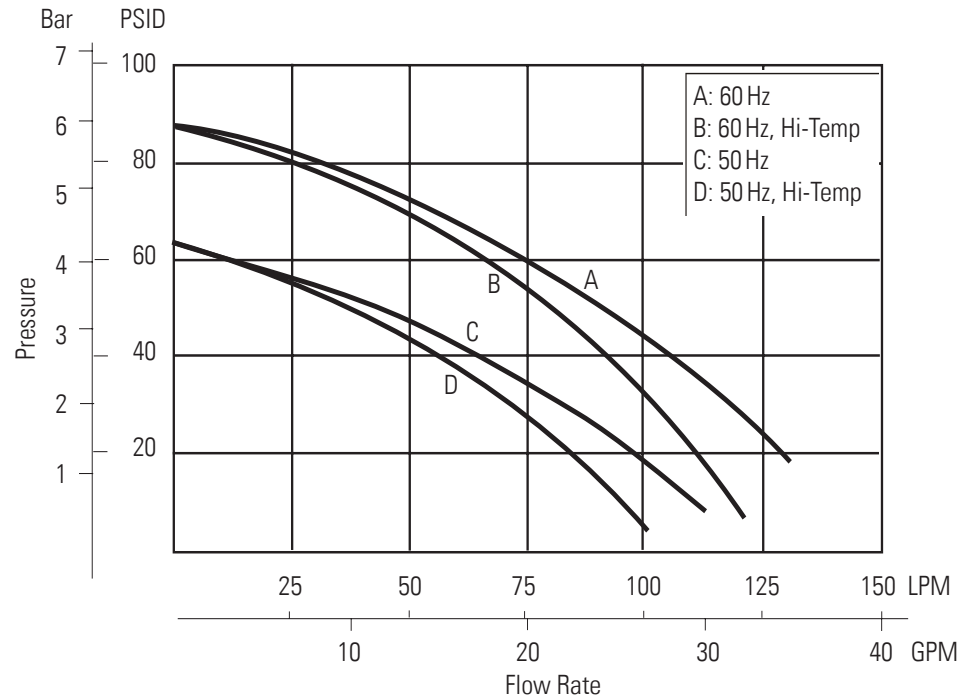

- Pump curves are nominal values. Pressure values for centrifugal pumps are differential pressures between the inlet and the outlet of the chiller.
- Pump performance results were obtained with no restrictions on the return to the system or with any options installed. For example, utilizing the DI option will result in a 0.5 gpm flow reduction.
- Specifications obtained at sea level using water as the recirculating fluid, at a 20°C process setpoint, 25°C ambient condition, at nominal operating voltage. Other fluids, fluid temperatures, ambient temperatures, altitude or operating voltages will affect performance. See Section 3.
- Thermo Fisher Scientific reserves the right to change specifications without notice.

**Pumping Capacity  
Turbine Pump T9**

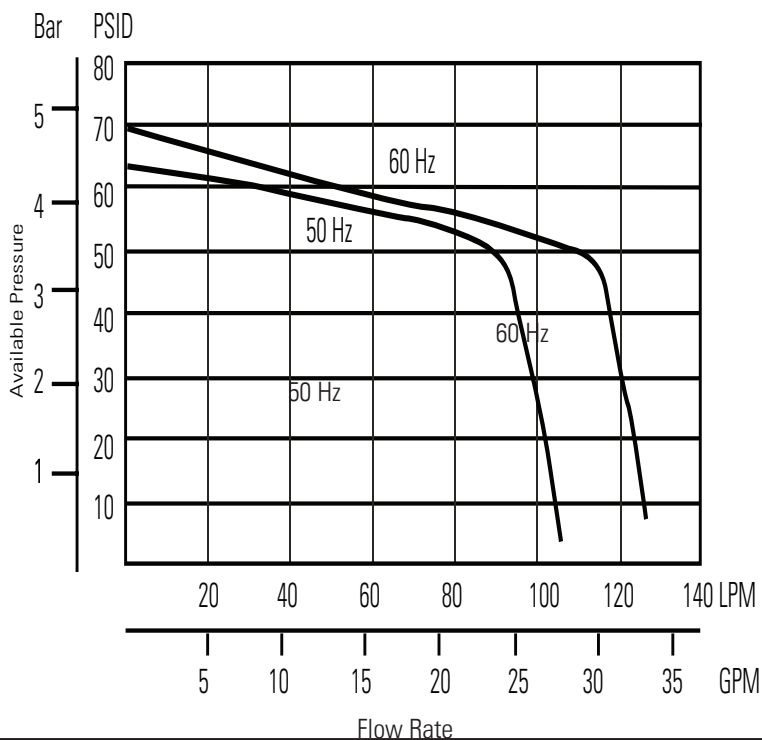

- Pump curves are nominal values. Pressure values for turbine pumps are differential pressures between the inlet and the outlet of the chiller.
- Pump performance results were obtained with no restrictions on the return to the system or with any options installed. For example, utilizing the DI option will result in a 0.5 gpm flow reduction.
- Specifications obtained at sea level using water as the recirculating fluid, at a 20°C process setpoint, 25°C ambient condition, at nominal operating voltage. Other fluids, fluid temperatures, ambient temperatures, altitude or operating voltages will affect performance. See Section 3.
- Thermo Fisher Scientific reserves the right to change specifications without notice.

**Pumping Capacity  
Turbine Pump T0**

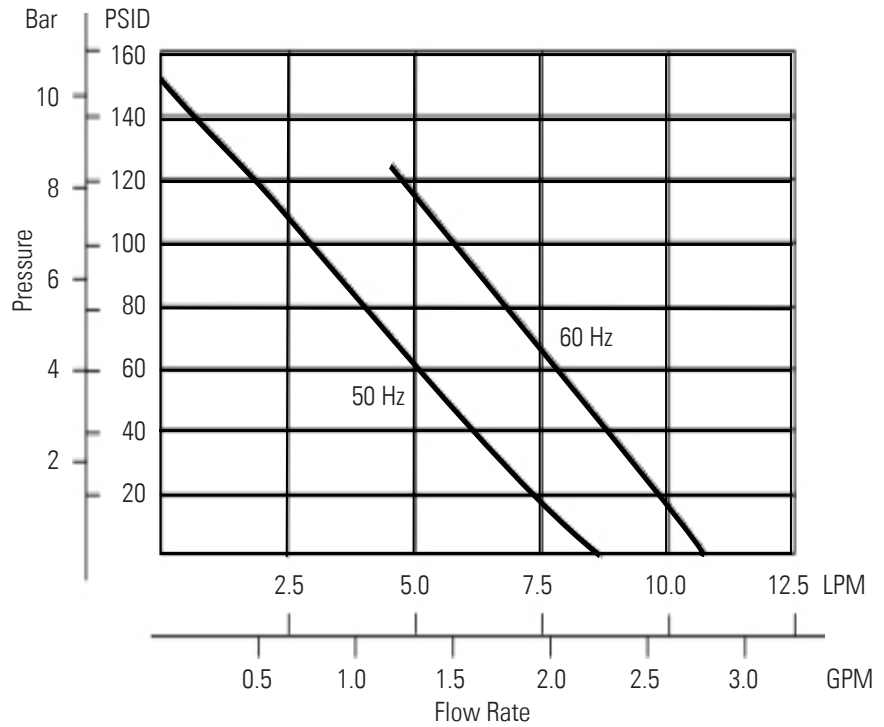

- Pump curves are nominal values. Pressure values for turbine pumps are differential pressures between the inlet and the outlet of the chiller.
- Pump performance results were obtained with no restrictions on the return to the system or with any options installed. For example, utilizing the DI option will result in a 0.5 gpm flow reduction .
- Specifications obtained at sea level using water as the recirculating fluid, at a 20°C process setpoint, 25°C ambient condition, at nominal operating voltage. Other fluids, fluid temperatures, ambient temperatures, altitude or operating voltages will affect performance. See Section 3.
- Thermo Fisher Scientific reserves the right to change specifications without notice.

**ThermoFlex900/1400**  
**Dimensions**  
 (inches/centimeters)

Front View

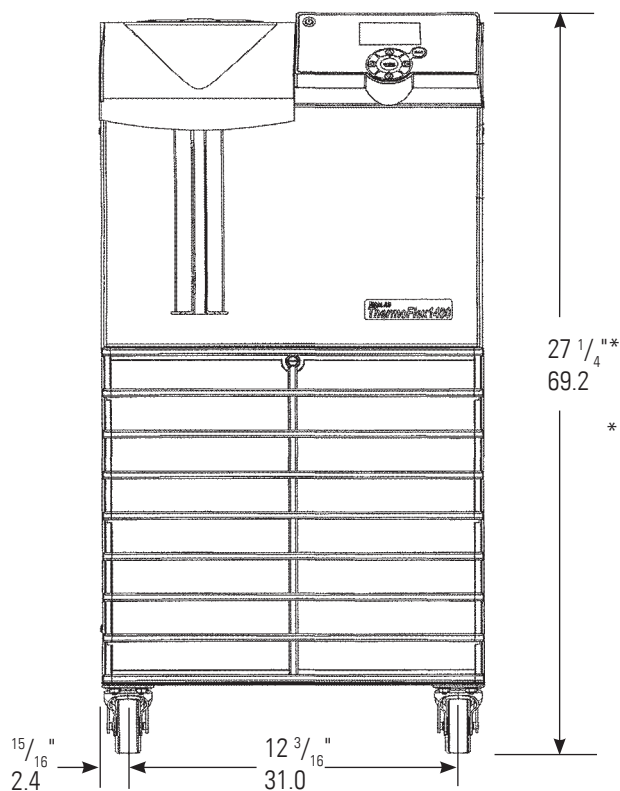

Side View

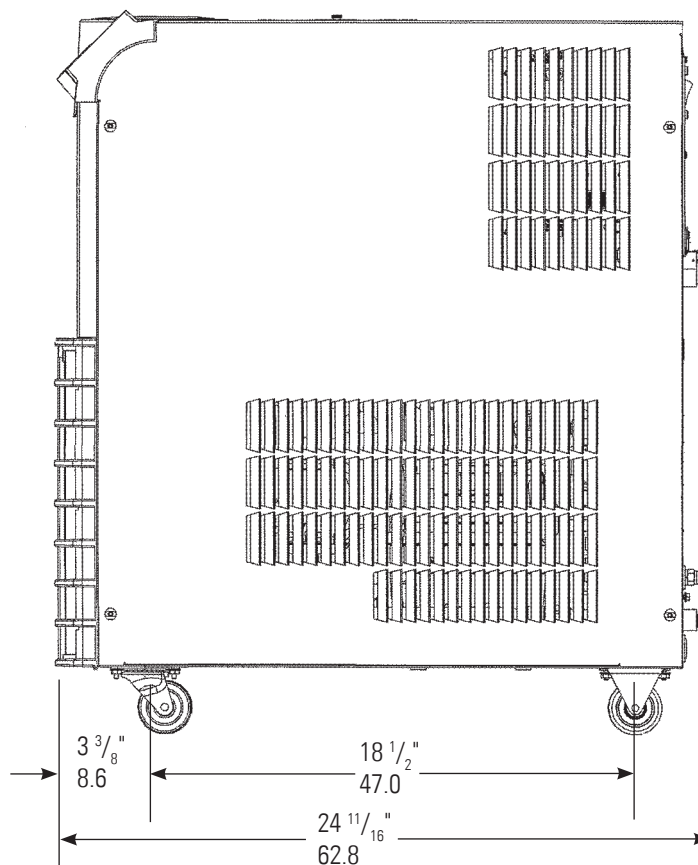

• Thermo Fisher Scientific reserves the right to change specifications without notice.

**ThermoFlex900/1400**

Process discharge for chillers with optional flow transducer or Internal pressure regulator adjustment (Optional)  
1/2" FNPT Stainless Steel

Rear View

Process discharge fluid connection  
1/2" FNPT Cast Bronze

Process fluid return connection  
1/2" FNPT Stainless Steel

See Section 3 for additional plumbing information.

Process fluid drain  
(1/4" FNPT) Riton

Optional 1/2" Auxiliary and 1/4" Auto-Refill Ports

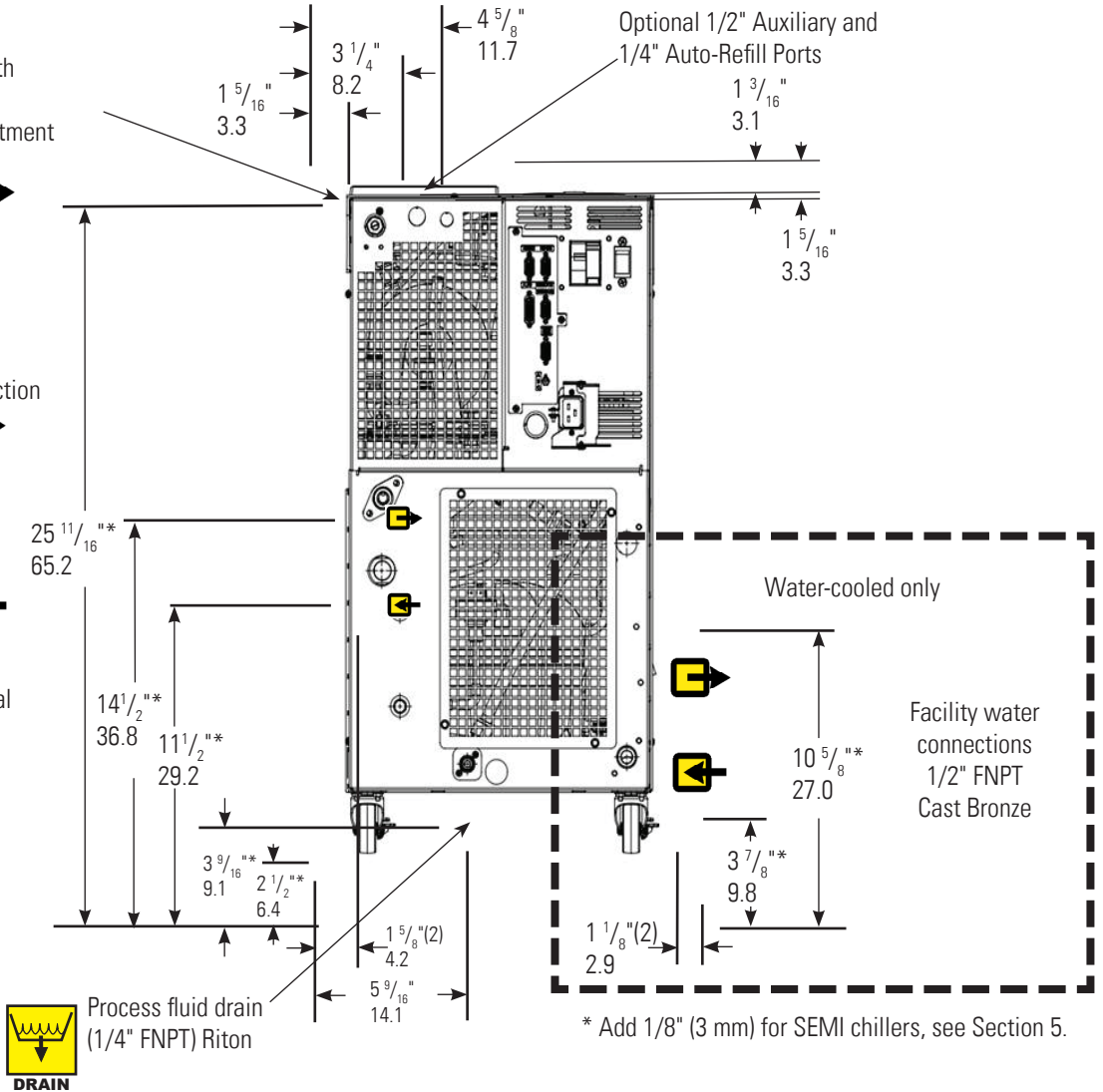

Top View

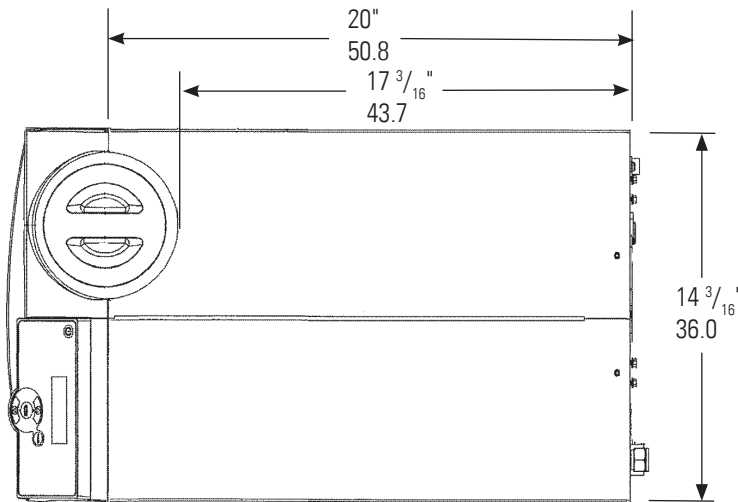

• Thermo Fisher Scientific reserves the right to change specifications without notice.



**ThermoFlex2500**  
**Dimensions**  
 (inches/centimeters)

Front View

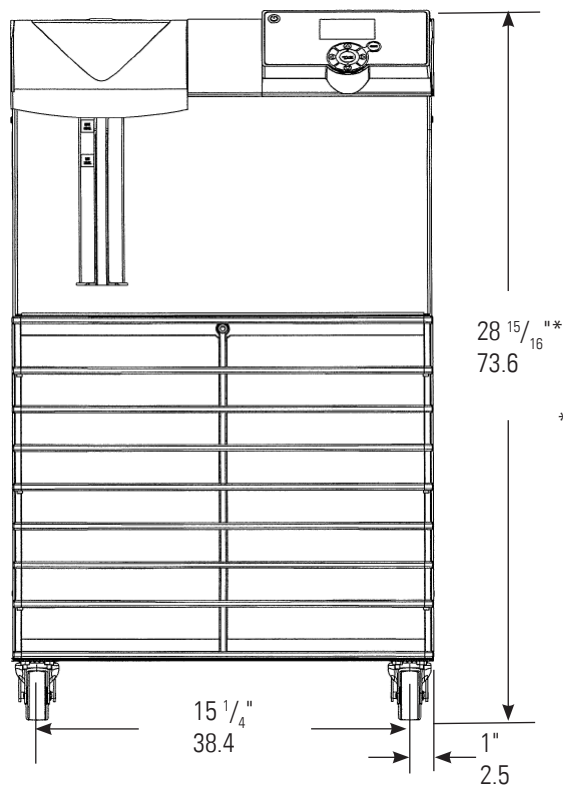

\* Add 1/8" (3 mm) for SEMI chillers, see Section 5.

Side View

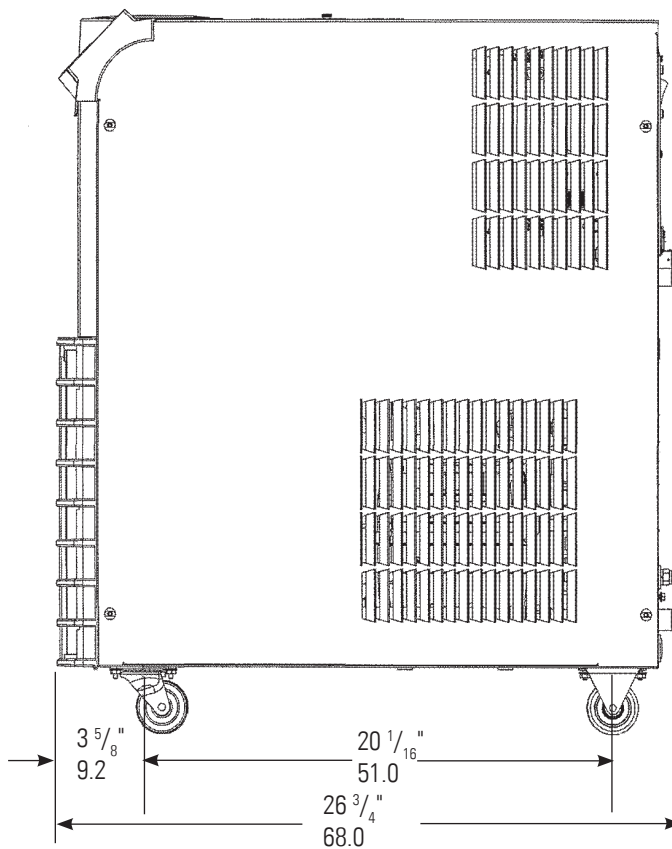

• Thermo Fisher Scientific reserves the right to change specifications without notice.

**ThermoFlex2500**

Process discharge for chillers with optional flow transducer or Internal pressure regulator adjustment (Optional)  
 1/2" FNPT Stainless Steel

Process discharge fluid connection  
 1/2" FNPT Cast Bronze

Process fluid return connection  
 1/2" FNPT Stainless Steel

Rear View

See Section 3 for additional plumbing information.



Process fluid drain (1/4" FNPT) Riton

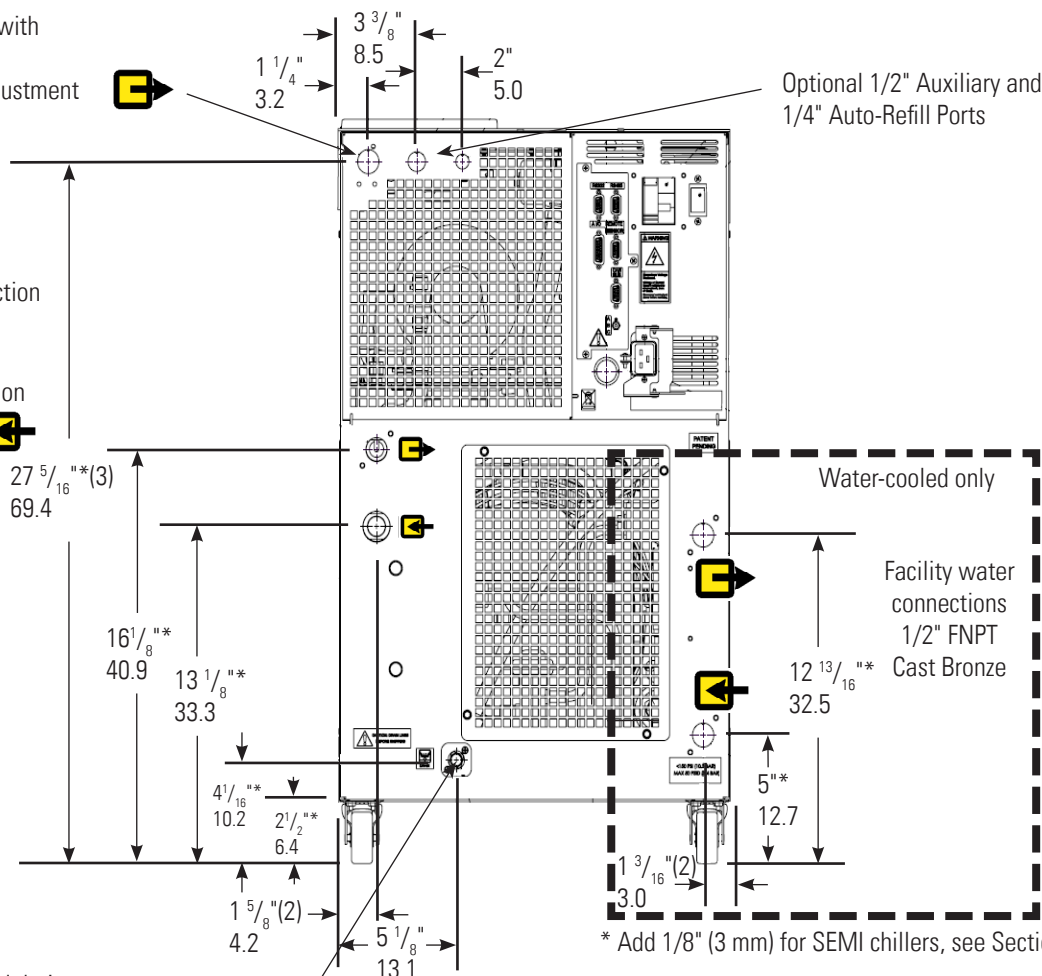

Top View

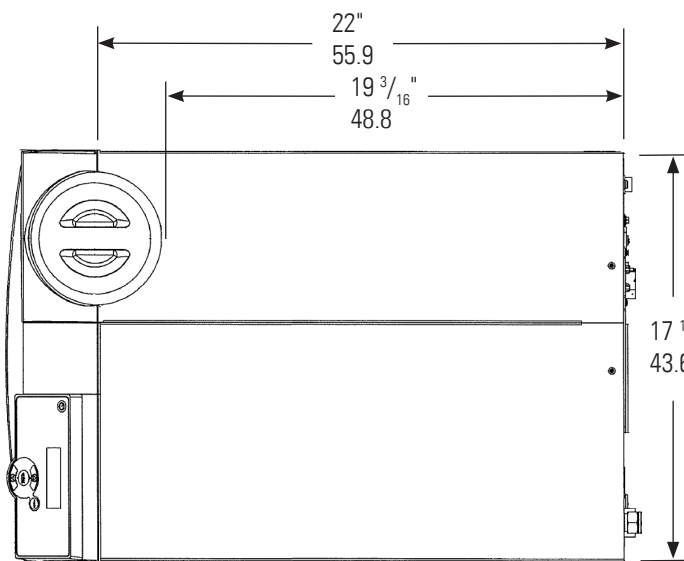

Shipping crate dimensions (approximate):  
 23" (58 cm) wide  
 36" (91 cm) tall  
 40" (102 cm) deep

- Thermo Fisher Scientific reserves the right to change specifications without notice.

**ThermoFlex3500/5000**  
**Dimensions**  
 (inches/centimeters)

Front View

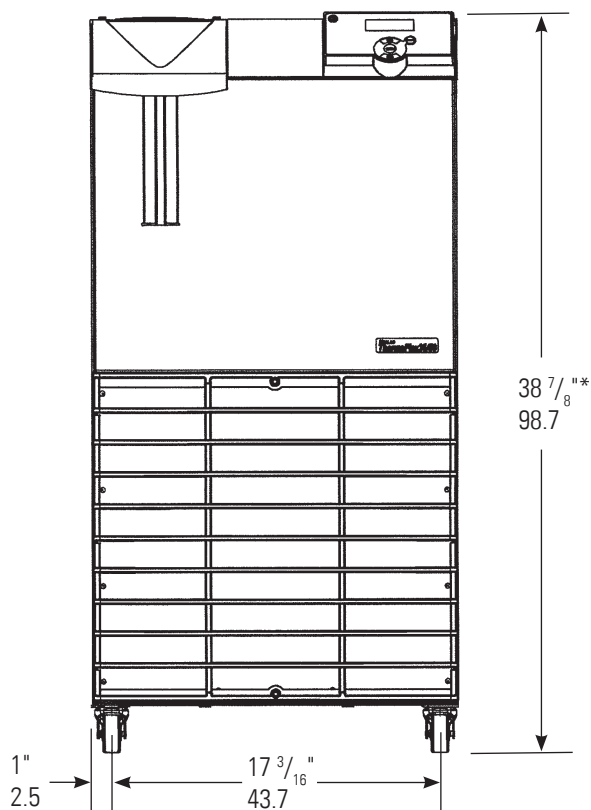

\* Add 1/8" (3 mm) for SEMI chillers, see Section 5.

Side View

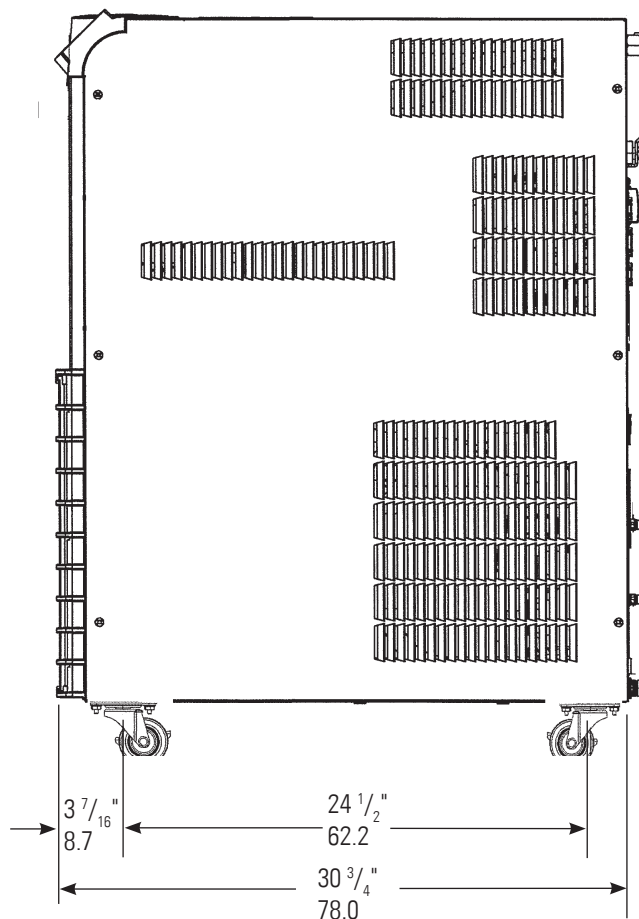

• Thermo Fisher Scientific reserves the right to change specifications without notice.

**ThermoFlex3500/5000**

Process discharge for chillers with optional flow transducer and P1, P2 & T1 pumps

or  
Internal pressure regulator adjustment (Optional P1/MD1, P2/MD2 & T1 only)

1/2" FNPT Stainless Steel

Process discharge connection  
Cast Bronze

A P3, P4 pumps 3/4" FNPT  
B P1/MD1, P2/MD2, T1 pumps  
1/2" FNPT

Process return connection  
Stainless Steel  
P3, P4 pumps 3/4" FNPT  
P1/MD1, P2/MD2, T1 pumps  
1/2" FNPT

See Section 3 for additional plumbing information.

Rear View

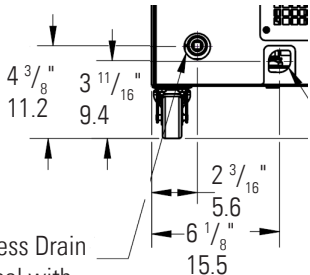
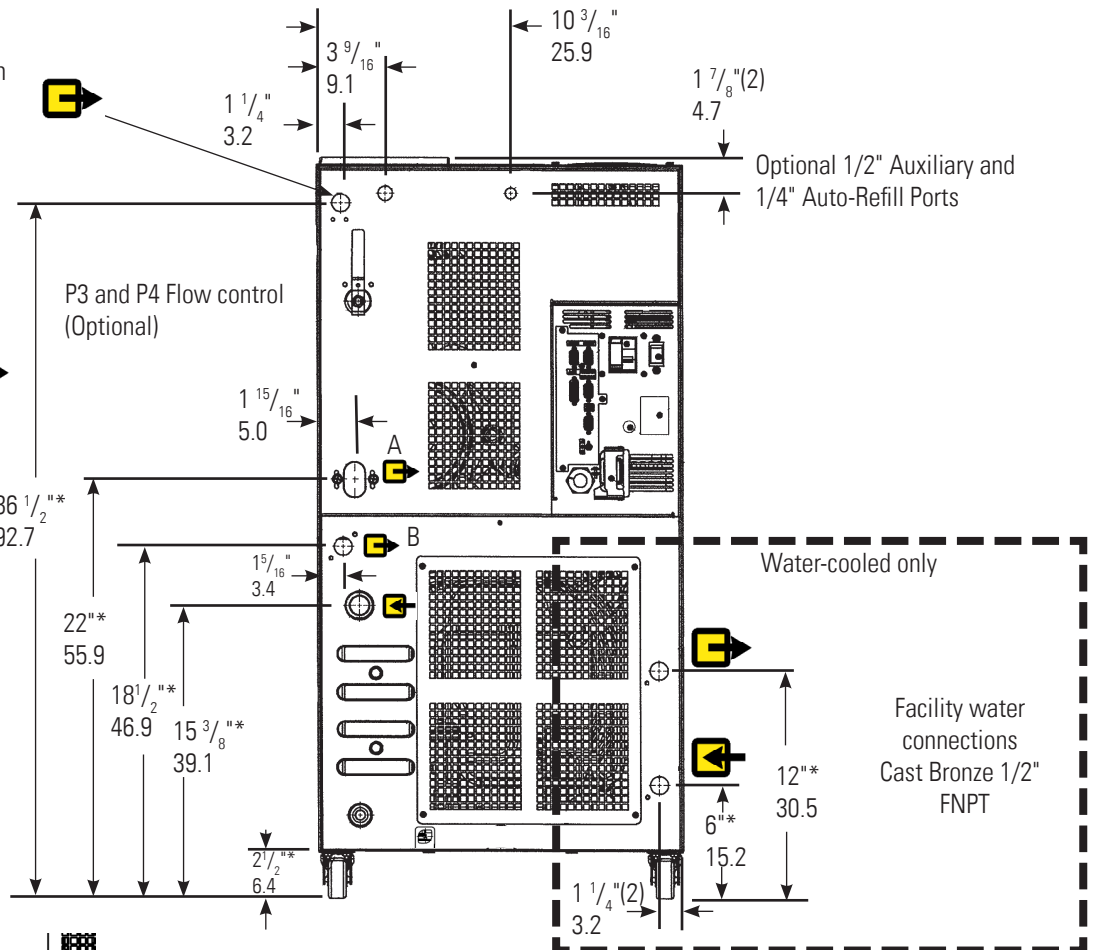

1/4" MPT Process Drain with 9/16" Riton connector (P1/MD1, P2/MD2 and TU1 pumps only)

1/4" FPT Process Drain  
Stainless Steel with 1/4" Brass plug (P3, P4 pumps only)

\* Add 1/8" (3 mm) for SEMI chillers, see Section 5.

Top View

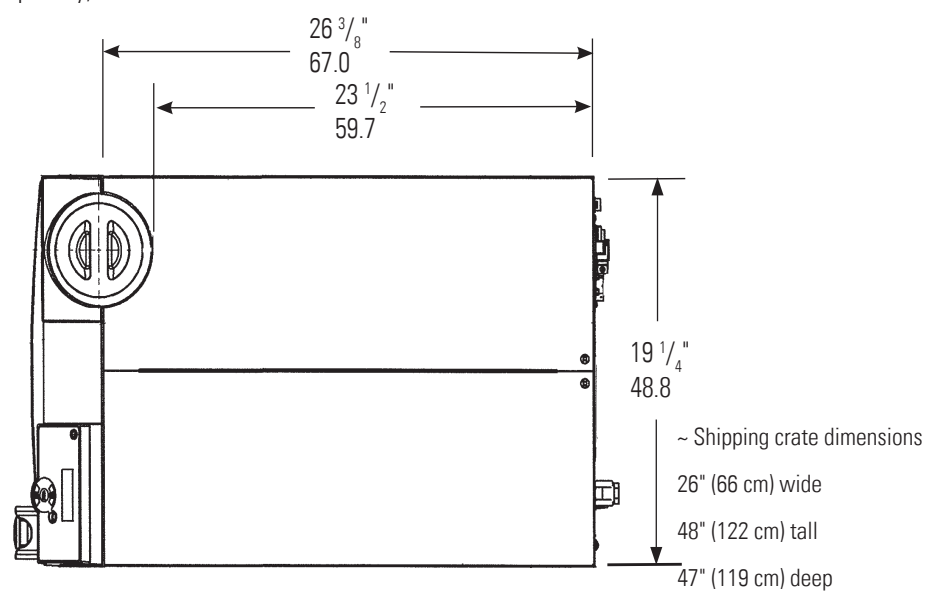

• Thermo Fisher Scientific reserves the right to change specifications without notice.

**ThermoFlex7500/10000**  
**Dimensions**  
 (inches/centimeters)

Side View

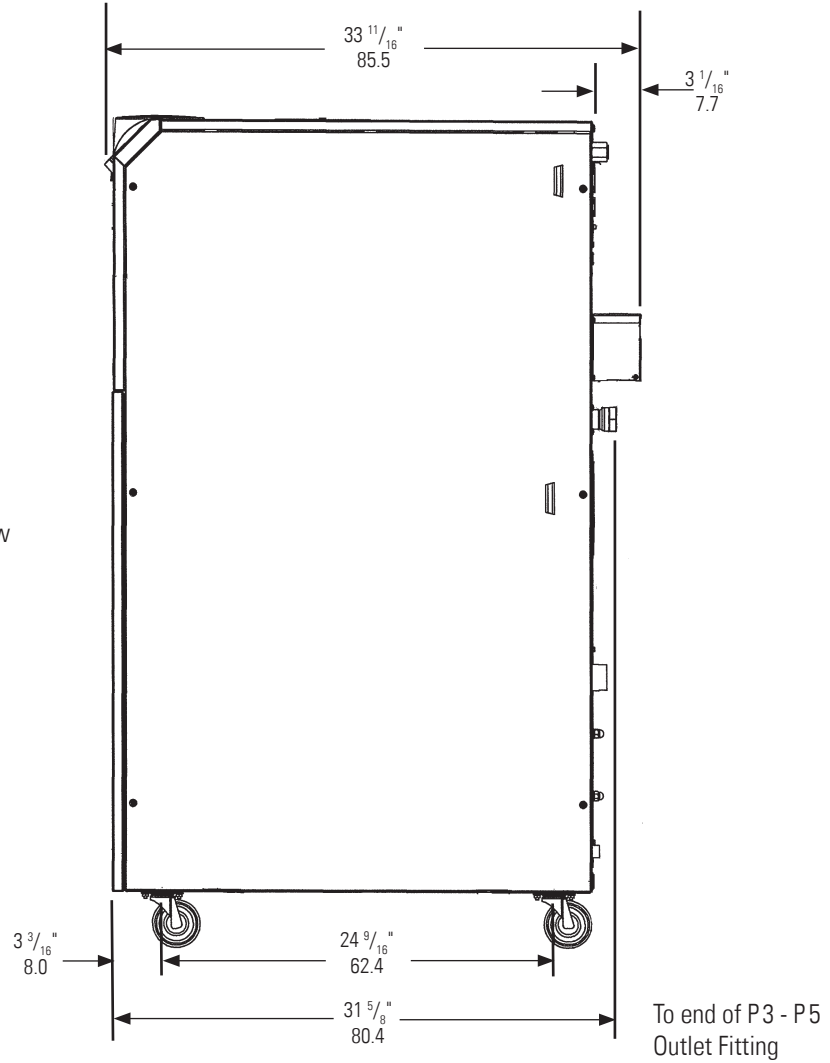

Top View

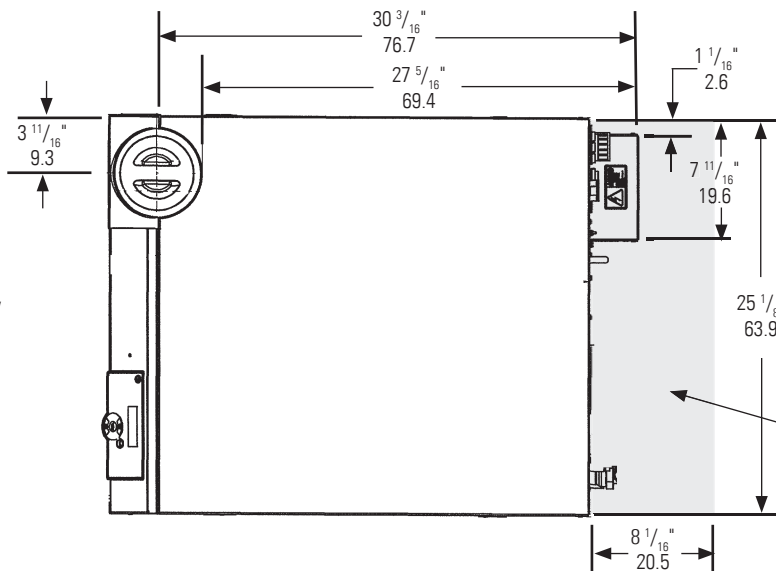

Air-cooled shipping crate dimensions (approximate):  
 35 3/4" (91 cm) wide  
 61 1/2" (156 cm) tall  
 46 3/8" (118 cm) deep

The applicable options fit within this envelope, see Section 5.

- Thermo Fisher Scientific reserves the right to change specifications without notice.



**ThermoFlex7500/10000**

Rear View  
(Air-Cooled)

Process Discharge   
P2/MD2 = 1/2" FNPT  
Cast Bronze

P3 - P5, T5= 1" FNPT  
Wrought Copper

Process Return   
Stainless Steel  
P2/MD2 = 1/2" FNPT  
P3 - P5, T5 = 1" FNPT

See Section 3 for  
additional plumbing  
information.

Process fluid drain (1/4" FNPT)  
Stainless Steel with Brass plug or  
a Riton connector



Rear View  
(Water-Cooled)

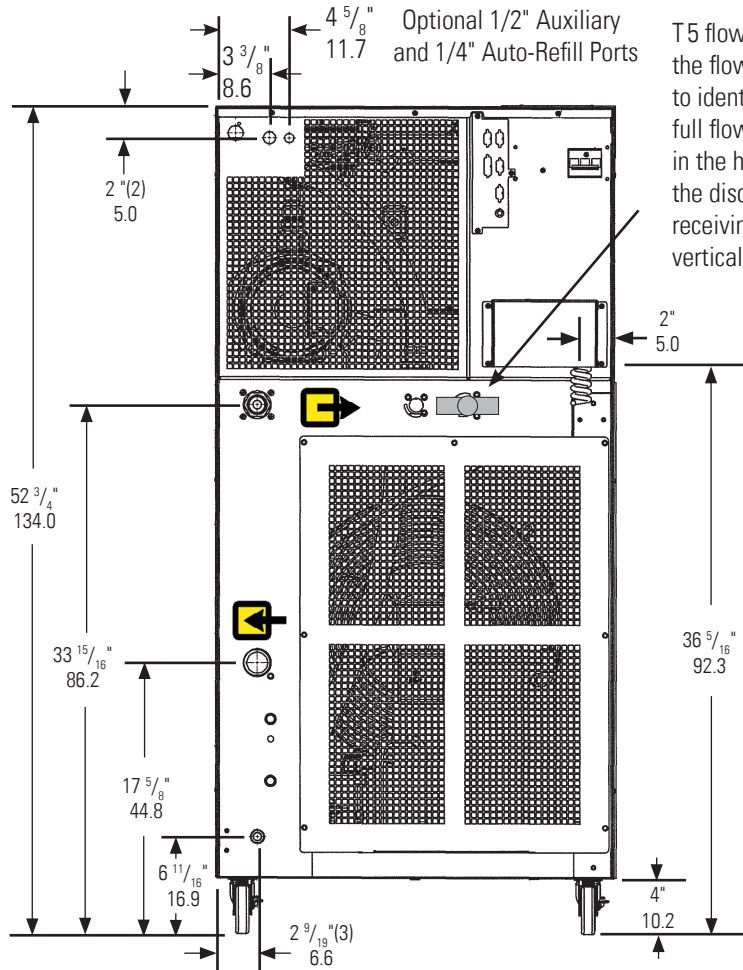

T5 flow control valve is used to adjust the flow rate. The handle is designed to identify the valve's position, from full flow to full bypass. When handle in the horizontal position (in line with the discharge line) the application is receiving full flow. With the handle is vertical the valve is in full bypass.

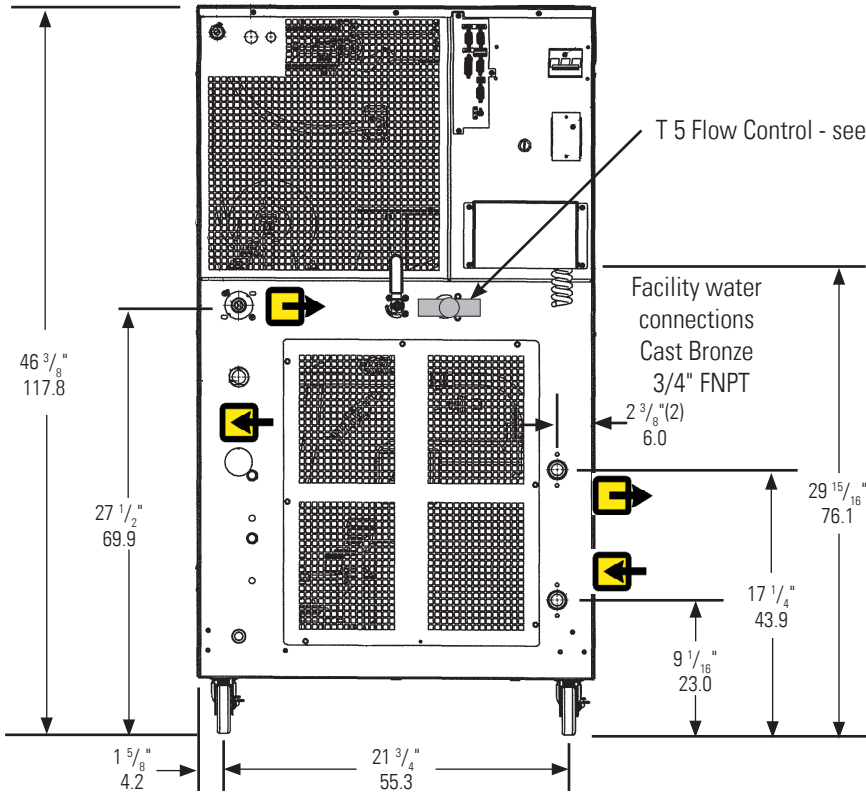
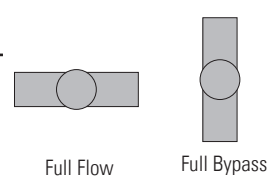

T 5 Flow Control - see above.

Facility water connections  
Cast Bronze  
3/4" FNPT

**ThermoFlex24000**  
**Dimensions**  
**(inches/centimeters)**

Front View

For ThermoFlex24000  
 Air-Cooled Chillers

58 <sup>5</sup>/<sub>8</sub> "  
 148.9

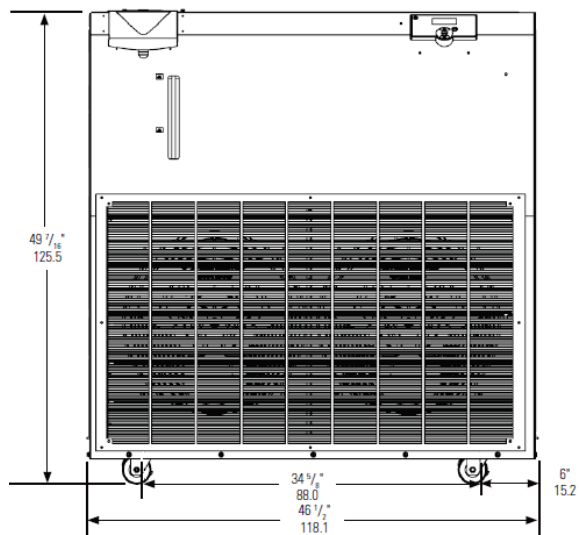

Side View

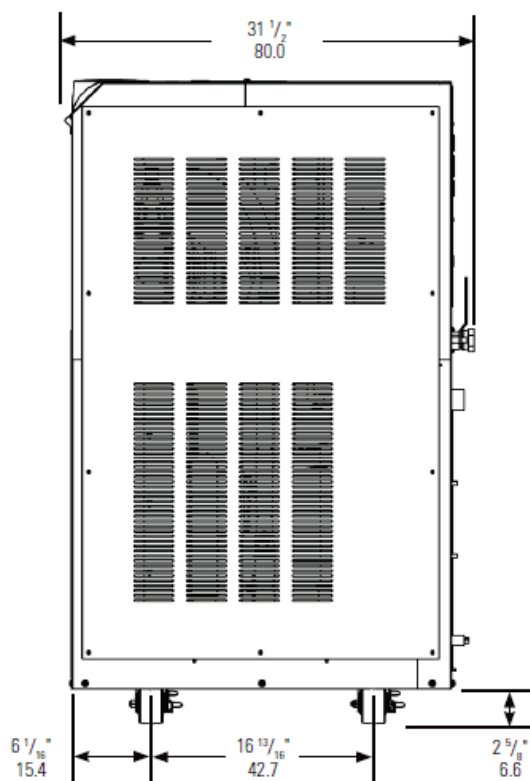

- Thermo Fisher Scientific reserves the right to change specifications without notice.

### ThermoFlex24000

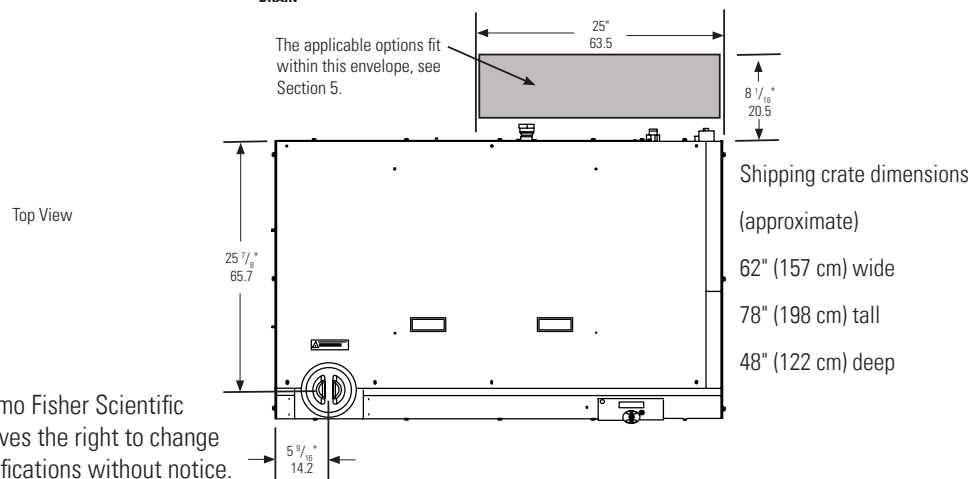
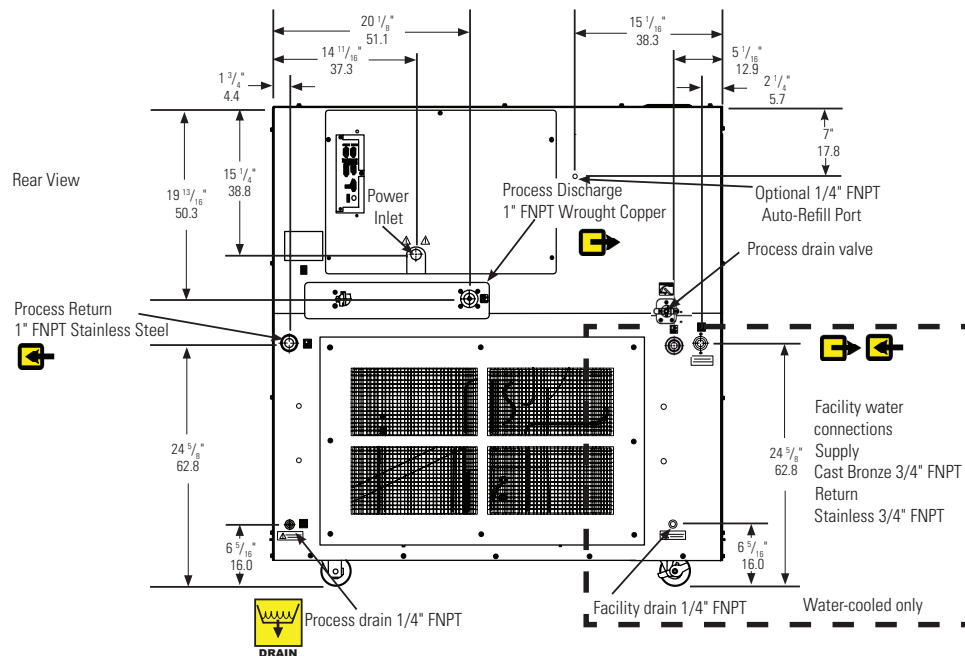

- Thermo Fisher Scientific reserves the right to change specifications without notice.

## Section 3 Installation

### Site Requirements

Ambient Temperature Range*	10°C to 40°C (50°F to 104°F)
Relative Humidity Range	10% to 80% (non-condensing)
Operating Altitude*	Sea Level to 8000 feet (2438 meters)
Overvoltage Category	II
Pollution Degree	2
Degree of Protection	IP 20

---

\*Because of the decrease in air density, maximum temperature for the air entering an air-cooled ThermoFlex is reduced by 1°C per 1,000 feet above sea level. In addition, cooling capacity is reduced 1.2% per 1,000 feet above sea level.



**Never place the chiller in a location where excessive heat, moisture, inadequate ventilation, or corrosive materials are present. ▲**

**Note** Refer to the nameplate information on the rear of the chiller. ▲

Air-cooled chillers retain their full rated capacity at 20°C setpoint in ambient temperatures up to 25°C (77°F). For ambient temperatures above 25°C please de-rate the cooling capacity 3% for every 1°C above 25°C (77°F), up to a maximum ambient temperature of 40°C (104°F). Note that when operating at a process temperature lower than 20°C the de-rate percentage may increase due to additional gains from losses to ambient.

**Note** Depending on the setpoint and ambient temperatures, there may be a heat gain or loss through the plumbing resulting in a variation from setpoint temperature at the application inlet. Applications with large temperature variations between ambient and setpoint temperatures, and/or long plumbing lengths, may require additional insulation. ▲

ThermoFlex2500 air-cooled chillers are equipped with a two-speed fan. Should the chiller's internal ambient temperature reach 50°C for 30 seconds, or reach 53°C, the fan speed switches from slow speed to high speed to maintain internal temperatures within acceptable limits. When the temperature reaches 44°C or below for at least 15 minutes the speed returns to low. When in high speed the chiller's decibel level increases significantly.

**Note** High speed is required for the chiller to achieve its 2500 watt cooling capacity. At high-end operating conditions the fan can be set to run at high speed all the time using the controller's **SETTINGS** display, see Section 4. ▲

Chillers installed below the end-user application may enable system fluid to drain back into the chiller and cause spillage. Thermo Fisher offers an anti-drainback kit to prevent any spillage, see Section 5.

Air-cooled chillers can be installed with both sides blocked, or one side and the rear. See Figure 3-1. The front needs a minimum clearance of 24". Air enters the front of the system and exits through the sides and rear.

Having two sides blocked can impact the chiller's performance due to changes in air flow. If your installation requires two blocked sides please ensure that the following requirements are met:

Process Setpoint Temperature: Below 30°C (86°F)

Ambient: Below 40°C (104°F)

Before operating the chiller in conditions outside any of those listed in this manual please contact Thermo Fisher Scientific's Sales, Service and Customer Support to review your installation.

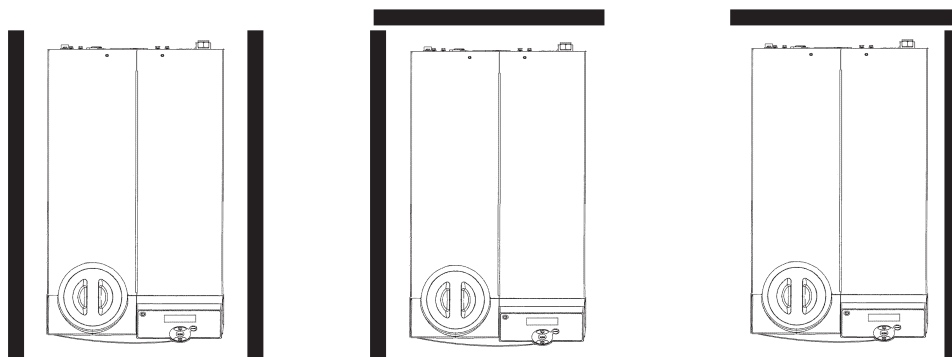

**Figure 3-1** Minimum Clearance



## Electrical Requirements



The chiller's construction provides protection against the risk of electrical shock by grounding appropriate metal parts. The protection will not function unless the power cord is connected to a properly grounded outlet. It is the user's responsibility to assure a proper ground connection is provided. ▲

The chiller must be installed in accordance with the National Electrical Code and the with reference to the information on the chiller's nameplate located on the rear.

Locate the chiller so it is near, and has easy access to, its disconnecting device.

The user is responsible to ensure that the line cord provided meets local electrical codes. If not, contact qualified installation personnel.

The chiller is intended for use on a dedicated outlet. The ThermoFlex has an internal circuit protection that is equivalent (approximately) to the branch circuit rating. This is to protect the ThermoFlex, and is not intended as a substitute for branch circuit protection.

Electrical Service Requirements (Standard temperature chillers):

<b>ThermoFlex900</b>	<b>Voltage ±10%</b>	<b>Frequency</b>	<b>Phase</b>	<b>Branch Circuit Requirements</b>	<b>Line Cord Plug</b>
	100 VAC	50 Hz	1Ø	15A	5-15P
	115 VAC	60 Hz	1Ø	15A	5-15P
	200 VAC	50 Hz	1Ø	15A	6-15P
	208-230 VAC	60 Hz	1Ø	15A	6-15P
	230 VAC	50 Hz	1Ø	*16A <sup>1</sup> , 15A <sup>2</sup> , 13A <sup>3</sup>	-
<b>ThermoFlex1400</b>	<b>Voltage ±10%</b>	<b>Frequency</b>	<b>Phase</b>	<b>Branch Circuit Requirements</b>	<b>Line Cord Plug</b>
	100 VAC	50 Hz	1Ø	20A	5-20P
	115 VAC	60 Hz	1Ø	20A	5-20P
	200 VAC	50 Hz	1Ø	15A	6-15P
	208-230 VAC	60 Hz	1Ø	15A	6-15P
	230 VAC	50 Hz	1Ø	*16A <sup>1</sup> , 15A <sup>2</sup> , 13A <sup>3</sup>	-
<b>ThermoFlex2500</b>	<b>Voltage ±10%</b>	<b>Frequency</b>	<b>Phase</b>	<b>Branch Circuit Requirements</b>	<b>Line Cord Plug</b>
	200 VAC P 1, P 2 Pump	50 Hz	1Ø	15A	6-15P
	208-230 VAC P 1, P 2 Pump	60 Hz	1Ø	15A	6-15P
	200 VAC T 1 Pump	50 Hz	1Ø	20A	6-20P
	208-230 VAC T 1 Pump	60 Hz	1Ø	20A	6-20P
	230 VAC	50 Hz	1Ø	*16A <sup>1</sup> , 15A <sup>2</sup> , 13A <sup>3</sup>	-

\* Refer to Appendix A for country specific ratings.

Continued on next page.

## Electrical Service Requirements (Standard temperature chillers):

ThermoFlex3500/5000	Voltage ±10%		Frequency	Phase	Branch Circuit Requirements		Line Cord Plug
		200 VAC P 1, P 2 Pump	50 Hz	1Ø	15A	6-15P	
	200 VAC T 1, P 3 Pump	50 Hz	1Ø	20A	6-20P		
	200 VAC P 4 Pump	50 Hz	1Ø	30A	L6-30P		
	208-230 VAC P 1, P 2 Pump	60 Hz	1Ø	15A	6-15P		
	208-230 VAC T 1, P 3 Pump	60 Hz	1Ø	20A	6-20P		
	208-230 VAC P 4 Pump	60 Hz	1Ø	30A	L6-30P		
	230 VAC P 1 - P 4 Pump	50 Hz	1Ø	*16A <sup>1</sup> , 15A <sup>2</sup> , 13A <sup>3</sup>		-	

ThermoFlex7500/10000 (Air-cooled)	Voltage ±10%		Frequency	Phase	MCA	MOPD	Line Cord Plug
		200 VAC P 2 Pump	50 Hz	3Ø	16.5	30	L15-20P
	200 VAC P 3 Pump	50 Hz	3Ø	18.7	30	L15-30P	
	200 VAC P 5 Pump	50 Hz	3Ø	22.3	35	L15-30P	
	200 VAC T 5 Pump	50 Hz	3Ø	17.3	30	L15-20P	
	208-230 VAC P 2 Pump	60 Hz	3Ø	16.5	30	L15-20P	
	208-230 VAC P 3 Pump	60 Hz	3Ø	18.7	30	L15-30P	
	208-230 VAC P 5 Pump	60 Hz	3Ø	22.3	35	L15-30P	
	208-230 VAC T 5 Pump	60 Hz	3Ø	17.3	30	L15-20P	
	400 VAC P 2 Pump	50 Hz	3Ø	10.9	20	IEC309	
	400 VAC P 3 Pump	50 Hz	3Ø	9.6	15	IEC309	
	400 VAC P 5 Pump	50 Hz	3Ø	11.8	15	IEC309	
	400 VAC T 5 Pump	50 Hz	3Ø	8.7	15	IEC309	

ThermoFlex7500/10000 (Water-cooled)	Voltage ±10%		Frequency	Phase	MCA	MOPD	Line Cord Plug
		200 VAC P 2 Pump	50 Hz	3Ø	16.2	30	L15-20P
	200 VAC P 3 Pump	50 Hz	3Ø	18.4	30	L15-30P	
	200 VAC P 5 Pump	50 Hz	3Ø	22.0	35	L15-30P	
	200 VAC T 5 Pump	50 Hz	3Ø	17.0	30	L15-20P	
	208-230 VAC P 2 Pump	60 Hz	3Ø	16.2	30	L15-20P	
	208-230 VAC P 3 Pump	60 Hz	3Ø	18.4	30	L15-30P	
	208-230 VAC P 5 Pump	60 Hz	3Ø	22.0	35	L15-30P	
	208-230 VAC T 5 Pump	60 Hz	3Ø	17.0	30	L15-20P	
	400 VAC P 2 Pump	50 Hz	3Ø	10.6	20	IEC309	
	400 VAC P 3 Pump	50 Hz	3Ø	9.3	15	IEC309	
	400 VAC P 5 Pump	50 Hz	3Ø	11.5	20	IEC309	
	400 VAC T 5 Pump	50 Hz	3Ø	8.4	15	IEC309	

**MCA** = Minimum Current Ampacity

**MOPD** = Maximum Overcurrent Protective Device

Values reflect those on the nameplate located on the rear of the chiller.

Continued on next page.

## Electrical Service Requirements (Variable voltage chillers):

ThermoFlex900	Voltage $\pm 10\%$	Frequency	Phase	Branch Circuit Requirements	Line Cord Plug
	115 VAC	60 Hz	1 $\emptyset$	15A	5-15P*
100 VAC	50/60 Hz	1 $\emptyset$	15A	5-15P*	

ThermoFlex1400	Voltage $\pm 10\%$	Frequency	Phase	Branch Circuit Requirements	Line Cord Plug
	115 VAC	60 Hz	1 $\emptyset$	20A	-
100 VAC	50/60 Hz	1 $\emptyset$	20A	-	

\* United States and Japan only. All other plugs are country specific.

## Electrical Service Requirements (Global voltage chillers):

ThermoFlex900	Voltage $\pm 10\%$	Frequency	Phase	Branch Circuit Requirements	Line Cord Plug
	200/208/230 VAC	60 Hz	1 $\emptyset$	15A	-
200/230 VAC	50 Hz	1 $\emptyset$	**16A <sup>1</sup> , 15A <sup>2</sup> , 13A <sup>3</sup>	-	

ThermoFlex1400	Voltage $\pm 10\%$	Frequency	Phase	Branch Circuit Requirements	Line Cord Plug
	200/208/230 VAC	60 Hz	1 $\emptyset$	15A	-
200/230 VAC	50 Hz	1 $\emptyset$	**16A <sup>1</sup> , 15A <sup>2</sup> , 13A <sup>3</sup>	-	

ThermoFlex2500	Voltage $\pm 10\%$	Frequency	Phase	Branch Circuit Requirements	Line Cord Plug
	200 VAC T 1 Pump	60 Hz	1 $\emptyset$	15A	-
	208-230 VAC T 1 Pump	60 Hz	1 $\emptyset$	20A	-
230 VAC	50 Hz	1 $\emptyset$	*16A <sup>1</sup> , 15A <sup>2</sup> , 13A <sup>3</sup>	-	

ThermoFlex3500/5000	Voltage $\pm 10\%$	Frequency	Phase	Branch Circuit Requirements	Line Cord Plug
	200/208-230 VAC P 1 P 3 Pump	50/60 Hz	1 $\emptyset$	15A	-
	200/208-230 VAC T 1 P 3 Pump	50/60 Hz	1 $\emptyset$	20A	-
200/208-230 VAC P 4 Pump	50/60 Hz	1 $\emptyset$	30A	Hard wired	

\*\* Chillers selected for 230 VAC operation have a range of -10% to +7%. Refer to Appendix A for country specific ratings.

For installation information on Variable Voltage and Global Voltage chillers refer to Appendix B. Refer to the nameplate label located on the rear of the chiller for specific electrical requirements.

Continued on next page.

## Electrical Service Requirements (Global voltage chillers):

<b>ThermoFlex7500/10000 (Air-cooled)</b>	<b>Voltage ±10%</b>	<b>Frequency</b>	<b>Phase</b>	<b>MCA</b>	<b>MOPD</b>	<b>Line Cord Plug</b>
	400 VAC P2 Pump	50 Hz	3Ø	8.8	15	Hard wire
	400 VAC P3 Pump	50 Hz	3Ø	10.1	20	Hard wire
	400 VAC P5 Pump	50 Hz	3Ø	12.3	20	Hard wire
	400 VAC T5 Pump	50 Hz	3Ø	9.1	15	Hard wire
	460 VAC P2 Pump	60 Hz	3Ø	8.8	15	Hard wire
	460 VAC P3 Pump	60 Hz	3Ø	10.1	20	Hard wire
	460 VAC P5 Pump	60 Hz	3Ø	12.3	20	Hard wire
	460 VAC T5 Pump	60 Hz	3Ø	9.1	15	Hard wire

<b>ThermoFlex7500/10000 (Water-cooled)</b>	<b>Voltage ±10%</b>	<b>Frequency</b>	<b>Phase</b>	<b>MCA</b>	<b>MOPD</b>	<b>Line Cord Plug</b>
	400 VAC P2 Pump	50 Hz	3Ø	8.4	15	Hard wire
	400 VAC P3 Pump	50 Hz	3Ø	9.7	20	Hard wire
	400 VAC P5 Pump	50 Hz	3Ø	11.9	20	Hard wire
	400 VAC T5 Pump	50 Hz	3Ø	8.8	15	Hard wire
	460 VAC P2 Pump	60 Hz	3Ø	8.4	15	Hard wire
	460 VAC P3 Pump	60 Hz	3Ø	9.7	20	Hard wire
	460 VAC P5 Pump	60 Hz	3Ø	11.6	20	Hard wire
	460 VAC T5 Pump	60 Hz	3Ø	8.8	15	Hard wire

## Electrical Service Requirements (High temperature chillers):

<b>ThermoFlex1400</b>	<b>Voltage ±10%</b>	<b>Frequency</b>	<b>Phase</b>	<b>Branch Circuit Requirements</b>	<b>Line Cord Plug</b>
	200 VAC 1KW	50 Hz	1Ø	20A	6-20P
	200-230 VAC 1KW	60 Hz	1Ø	20A	6-20P
	200 VAC 2KW	50 Hz	1Ø	30A	6-30P
	208-230 VAC 2KW	60 Hz	1Ø	30A	6-30P
	230 VAC 2KW	50 Hz	1Ø	32A	-
	230 VAC 1KW	50 Hz	1Ø	*16A <sup>1</sup> , 15A <sup>2</sup> , 13A <sup>3</sup>	-

<b>ThermoFlex2500</b>	<b>Voltage ±10%</b>	<b>Frequency</b>	<b>Phase</b>	<b>Branch Circuit Requirements</b>	<b>Line Cord Plug</b>
	200 VAC P1 P2 Pump	50 Hz	1Ø	30A	6-30P
	208-230 VAC P1 P2 Pump	60 Hz	1Ø	30A	6-30P
	208-230 VAC T1 Pump	60 Hz	1Ø	30A	6-30P
	200 VAC T1 Pump	50 Hz	1Ø	40A	Hard wire
	230 VAC	50 Hz	1Ø	32A	-

\* Refer to Appendix A for country specific ratings.

Continued on next page.

## Electrical Service Requirements (High temperature chillers):

<b>ThermoFlex3500/5000</b>	<b>Voltage ±10%</b>	<b>Frequency</b>	<b>Phase</b>	<b>Branch Circuit Requirements</b>	<b>Line Cord Plug</b>
	200 VAC P1 P2 Pump	50 Hz	1Ø	30A	6-30P
	200 VAC T1 P3 P4 Pump	50 Hz	1Ø	40A	Hard wire
	208-230 VAC P1 P2 Pump	60 Hz	1Ø	30A	6-30P
	208-230 VAC T1 P3 P4 Pump	60 Hz	1Ø	40A	Hard wire
	230 VAC P1- P4, T1 Pump	50 Hz	1Ø	32A	IEC309

<b>ThermoFlex7500/10000 (Air-cooled)</b>	<b>Voltage ±10%</b>	<b>Frequency</b>	<b>Phase</b>	<b>MCA</b>	<b>MOPD</b>	<b>Line Cord Plug</b>
	200 VAC P2 Pump	50 Hz	3Ø	35.7	45	Hard wire
	200 VAC P3 Pump	50 Hz	3Ø	37.9	45	Hard wire
	200 VAC P5 Pump	50 Hz	3Ø	41.5	50	Hard wire
	200 VAC T5 Pump	50 Hz	3Ø	36.4	45	Hard wire
	208-230 VAC P2 Pump	60 Hz	3Ø	35.7	45	Hard wire
	208-230 VAC P3 Pump	60 Hz	3Ø	37.9	45	Hard wire
	208-230 VAC P5 Pump	60 Hz	3Ø	41.5	50	Hard wire
	208-230 VAC T5 Pump	60 Hz	3Ø	36.4	45	Hard wire
	400 VAC P2 Pump	50 Hz	3Ø	19.2	25	Hard wire
	400 VAC P3 Pump	50 Hz	3Ø	17.9	25	Hard wire
	400 VAC P5 Pump	50 Hz	3Ø	20.1	25	Hard wire
	400 VAC T5 Pump	50 Hz	3Ø	17.0	25	Hard wire

<b>ThermoFlex7500/10000 (Water-cooled)</b>	<b>Voltage ±10%</b>	<b>Frequency</b>	<b>Phase</b>	<b>MCA</b>	<b>MOPD</b>	<b>Line Cord Plug</b>
	200 VAC P2 Pump	50 Hz	3Ø	35.3	45	L15-20P
	200 VAC P3 Pump	50 Hz	3Ø	37.5	45	L15-20P
	200 VAC P5 Pump	50 Hz	3Ø	41.1	50	L15-30P
	200 VAC T5 Pump	50 Hz	3Ø	36.1	45	L15-30P
	208-230 VAC P2 Pump	60 Hz	3Ø	35.3	45	L15-20P
	208-230 VAC P3 Pump	60 Hz	3Ø	37.5	45	L15-20P
	208-230 VAC P5 Pump	60 Hz	3Ø	41.1	50	L15-30P
	208-230 VAC T5 Pump	60 Hz	3Ø	36.1	45	L15-30P
	400 VAC P2 Pump	50 Hz	3Ø	18.8	25	IEC309
	400 VAC P3 Pump	50 Hz	3Ø	17.5	25	IEC309
	400 VAC P5 Pump	50 Hz	3Ø	19.7	25	IEC309
	400 VAC T5 Pump	50 Hz	3Ø	16.7	25	IEC309

**MCA** = Minimum Current Ampacity

**MOPD** = Maximum Overcurrent Protective Device

Values reflect those on the nameplate located on the rear of the chiller.

Continued on next page.



<b>ThermoFlex24000 (Air-cooled)</b>	<b>Voltage ±10%</b>	<b>Frequency</b>	<b>Phase</b>	<b>MCA</b>	<b>MOPD</b>	<b>Line Cord Plug</b>
	208-230 VAC P 3 Pump	60 Hz	3∅	68.4	100	Hard wire
	208-230 VAC P 5 Pump	60 Hz	3∅	72	100	Hard wire
	400 VAC P 3 Pump	50 Hz	3∅	20.1	35	Hard wire
	400 VAC P 5 Pump	50 Hz	3∅	22.3	40	Hard wire
	208-230 VAC T 9 Pump	60 Hz	3∅	77.8	105	Hard wire

<b>ThermoFlex24000 (Water-cooled)</b>	<b>Voltage ±10%</b>	<b>Frequency</b>	<b>Phase</b>	<b>MCA</b>	<b>MOPD</b>	<b>Line Cord Plug</b>
	208-230 VAC P 3 Pump	60 Hz	3∅	61.6	90	Hard wire
	208-230 VAC P 5 Pump	60 Hz	3∅	65.2	100	Hard wire
	400 VAC P 3 Pump	50 Hz	3∅	18.8	35	Hard wire
	400 VAC P 5 Pump	50 Hz	3∅	21.0	35	Hard wire
	208-230 VAC T 9 Pump	60 Hz	3∅	71	100	Hard wire

## Electrical Service Requirements (High temperature global voltage chillers):

ThermoFlex1400	Voltage ±10%	Frequency	Phase	Branch Circuit Requirements		Line Cord Plug
	200/208/230 VAC 1KW	60 Hz	1Ø	20A		
200/208/230 VAC 2KW	60 Hz	1Ø	30A			Hard wire
200/230 VAC 2KW	50 Hz	1Ø	32A			Hard wire
200/230 VAC 1KW	50 Hz	1Ø	**16A <sup>1</sup> , 15A <sup>2</sup> , 13A <sup>3</sup>			Hard wire

ThermoFlex2500	Voltage ±10%	Frequency	Phase	Branch Circuit Requirements		Line Cord Plug
	200/208/230 VAC P1 P2 Pump	60 Hz	1Ø	30A		
200/208/230 VAC T1 Pump	60 Hz	1Ø	40A			Hard wire
200/230 VAC	50 Hz	1Ø	32A			Hard wire

ThermoFlex3500/5000	Voltage ±10%	Frequency	Phase	Branch Circuit Requirements		Line Cord Plug
	200/208-230 VAC P1 P2 Pump	50/60 Hz	1Ø	30, 32A		
200/208-230 VAC T1 P3 P4 Pump	50/60 Hz	1Ø	32, 40A			Hard wire

ThermoFlex7500/10000 (Air-cooled)	Voltage ±10%	Frequency	Phase	MCA	MOPD	Line Cord Plug
	400 VAC P2 Pump	50 Hz	3Ø	18.3	25	Hard wire
400 VAC P3 Pump	50 Hz	3Ø	19.6	25	Hard wire	
400 VAC P5 Pump	50 Hz	3Ø	21.8	30	Hard wire	
400 VAC T5 Pump	50 Hz	3Ø	18.7	25	Hard wire	
460 VAC P2 Pump	60 Hz	3Ø	18.3	25	Hard wire	
460 VAC P3 Pump	60 Hz	3Ø	19.6	25	Hard wire	
460 VAC P5 Pump	60 Hz	3Ø	21.8	30	Hard wire	
460 VAC T5 Pump	60 Hz	3Ø	18.7	25	Hard wire	

ThermoFlex7500/10000 (Water-cooled)	Voltage ±10%	Frequency	Phase	MCA	MOPD	Line Cord Plug
	400 VAC P2 Pump	50 Hz	3Ø	18.0	25	Hard wire
400 VAC P3 Pump	50 Hz	3Ø	19.3	25	Hard wire	
400 VAC P5 Pump	50 Hz	3Ø	21.5	30	Hard wire	
400 VAC T5 Pump	50 Hz	3Ø	18.4	25	Hard wire	
460 VAC P2 Pump	60 Hz	3Ø	18.0	25	Hard wire	
460 VAC P3 Pump	60 Hz	3Ø	19.3	25	Hard wire	
460 VAC P5 Pump	60 Hz	3Ø	21.5	30	Hard wire	
460 VAC T5 Pump	60 Hz	3Ø	18.4	25	Hard wire	

\*\* Chillers selected for 230 VAC operation have a range of -10% to +7%. Refer to Appendix A for country specific ratings.

For installation information Global Voltage chillers refer to Appendix B.

Refer to the nameplate on the chiller's rear for specific electrical requirements.

<b>ThermoFlex24000 (Air-cooled)</b>	<b>Voltage ±10%</b>	<b>Frequency</b>	<b>Phase</b>	<b>MCA</b>	<b>MOPD</b>	<b>Line Cord Plug</b>
	400 VAC P 3 Pump	50 Hz	3∅	29.6	45	Hard wire
	400 VAC P 5 Pump	50 Hz	3∅	31.8	45	Hard wire
	460 VAC P 3 Pump	60 Hz	3∅	29.6	45	Hard wire
	460 VAC P 5 Pump	60 Hz	3∅	31.8	45	Hard wire
	400 VAC T 9 Pump	50 Hz	3∅	33.3	45	Hard wire
	460 VAC T 9 Pump	60 Hz	3∅	33.3	45	Hard wire

<b>ThermoFlex24000 (Water-cooled)</b>	<b>Voltage ±10%</b>	<b>Frequency</b>	<b>Phase</b>	<b>MCA</b>	<b>MOPD</b>	<b>Line Cord Plug</b>
	400 VAC P 3 Pump	50 Hz	3∅	28.4	40	Hard wire
	400 VAC P 5 Pump	50 Hz	3∅	30.6	45	Hard wire
	460 VAC P 3 Pump	60 Hz	3∅	28.4	40	Hard wire
	460 VAC P 5 Pump	60 Hz	3∅	30.6	45	Hard wire
	400 VAC T 9 Pump	50 Hz	3∅	32.1	45	Hard wire
	460 VAC T 9 Pump	60 Hz	3∅	32.1	45	Hard wire

## Hard Wire Installation



For personal safety and equipment reliability, only a qualified technician should perform the following procedure. ▲

**Note** The technician is responsible for installing circuit protection for incoming power. Before wiring consult the nameplate on the rear of the chiller. Ensure installation is in accordance with the National Electrical Code and any other applicable country and local codes. ▲

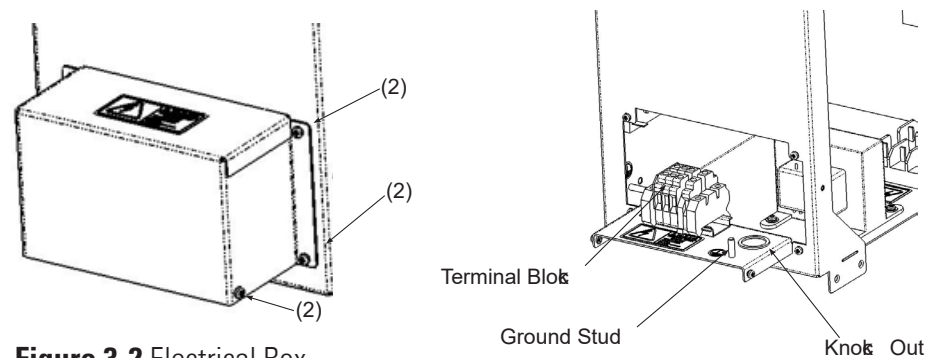

**Figure 3-2** Electrical Box

- Remove the six screws securing the electrical box cover to the rear of the chiller.
- Remove the double knock out ( $\frac{7}{8}$ " and  $1\frac{3}{32}$ ").
- Insert the cable through the hole.
- Refer to the label in the electrical box to configure your chiller, see Figure 3-3.
- Secure the cable's ground wire to the ground stud.
- Reinstall the cover.

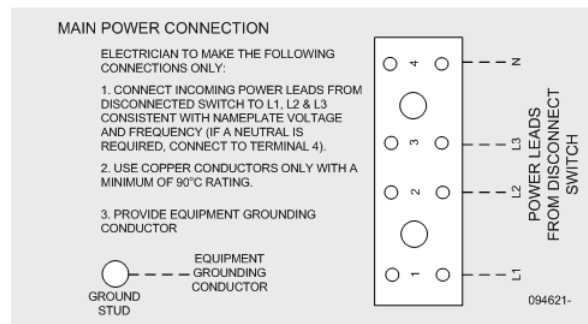

**Figure 3-3** Sample Label

### For ThermoFlex15000, 20000and 24000 chillers

- Remove the five screws securing the electrical panel to the chiller.
- Refer to the label in the electric box to configure you chiller, see Figure 3-3
- Secure the cable's ground wire to the ground stud.
- Reinstall the cover.

## Plumbing Requirements



Ensure that all shipping plugs are removed before installation.

Never connect the process fluid lines to your facility water supply or any pressurized liquid source. ▲

To prevent damage to the chiller's plate exchanger, centrifugal pumps require a 4.0 gpm (15.1 lpm) minimum flow rate. ▲

P1 and P2 pumps are capable of producing 185 psig. Ensure your plumbing is rated to withstand this pressure at your operating temperature. An external pressure relief valve is available, see Section 5. ▲

**Note** Ensure your plumbing installation will develop a back pressure to the ThermoFlex greater than 3 PSIG. Lower pressure will shut down the chiller. ▲

The process fluid connections are located on the rear of the chiller and are labeled (PROCESS OUTLET) and (PROCESS INLET).

### Process Fluid Connections (FNPT)

Outlet

Thermoflex 10 P1/P2 T0/T1 1/2 cast bronze

Thermoflex 60 P3/4 3/4 cast bronze

Thermoflex 80 P5/T5/T9 1" wrought copper

Inlet - Same size as outlet all chillers stainless steel

### Specified Adapters Standard Temperature Chillers

P1/P2 T0/T1 1/2" 8' brass by the end 2 x 2 brass

P3/4 3/4" MPT x 2" brass VC

P5/T5/T9 1" MPT x 1" brass VC and MPT x 4" brass VC

The specified adapters for high temperature chillers are brass.

Stainless steel outlet connection for chillers with P1/P2 pumps and a flow transducer

See Section 2 for the specific locations on your chiller.

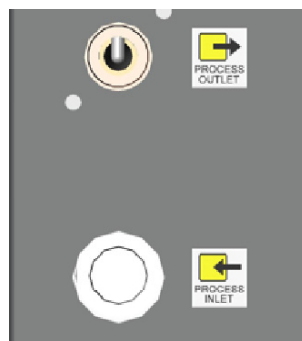

1/4" Female NPT Riton Reservoir Drain Plug

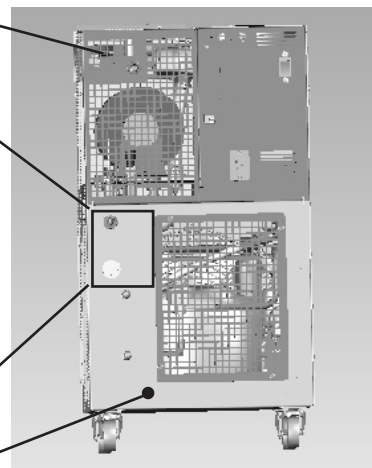



**Figure 3-4** Typical Plumbing Connections (1 of 2)

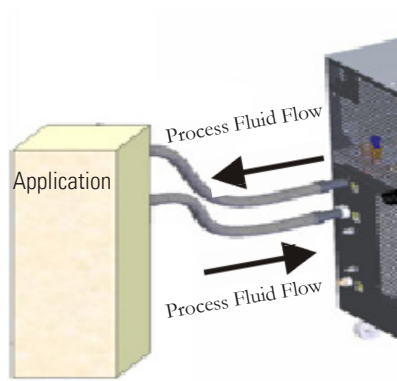







**Figure 3-4** Typical Plumbing Connections (2 of 2)

Connect the PROCESS OUTLET  to the fluid inlet on your application. Connect the PROCESS INLET  to the fluid outlet on your application. Ensure all connections are secure and that the proper sealant/lubricant for the fitting material is used. (If Teflon<sup>®</sup> tape is used, ensure the tape does not overhang the first thread as it could shred and get into the fluid.) Keep the distance between the chiller and the instrument being cooled as short as possible. Ensure tubing is straight and without bends. If diameter reductions are required, make them at the inlet and outlet of your application, not at the ThermoFlex.

### Water-cooled Chillers

For water-cooled chillers the facility water plumbing connections are also located on the rear and are labeled  FACILITY INLET and  FACILITY OUTLET. The connections are 1/2" Female NPT for ThermoFlex900 - 5000, 3/4" Female NPT for ThermoFlex7500 - 24000. Both connections for ThermoFlex900 to 10000 are cast bronze.

The supply connections for ThermoFlex24000 are cast bronze, the return connections are stainless steel.

Connect the  FACILITY INLET to your facility water supply. Connect the  FACILITY OUTLET to your facility water return or drain. Ensure all connections are secure and that the proper sealant/lubricant for the fitting material is used. (If Teflon<sup>®</sup> tape is used, ensure the tape does not overhang the first thread as it could shred and get into the fluid.)

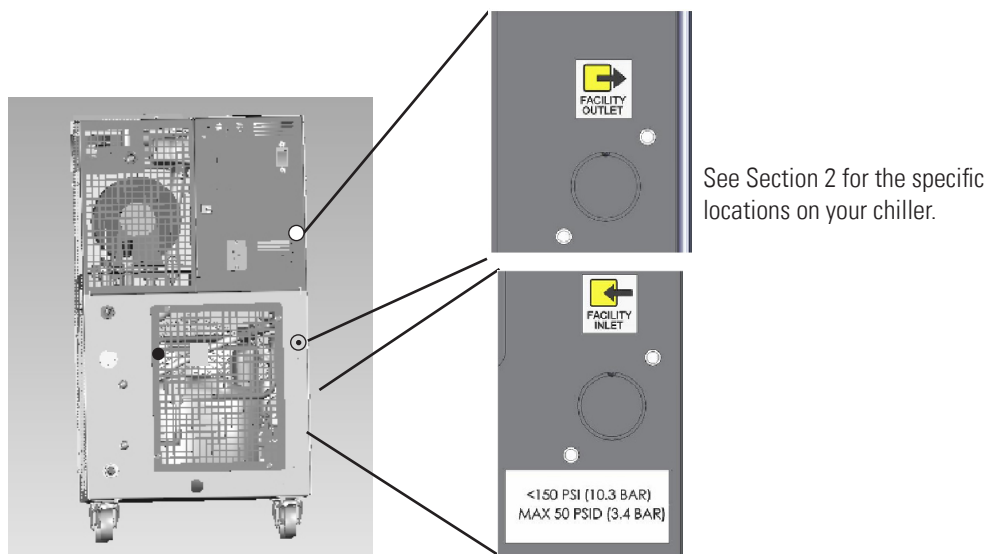

**Figure 3-5** Typical Plumbing Connections, Water-cooled Chillers

## Process Fluid Requirements



Use of any fluid not listed below will void the manufacturer's warranty. ▲

Standard Temp Chillers	High Temp Chillers
Filtered/Single Distilled water  0 - 75% Laboratory Grade Ethylene Glycol/Water  0 - 75% Laboratory Grade Propylene Glycol/Water  Deionized water (1 - 3 MΩ- cm, compensated)* *For applications requiring resistivity greater than 1 MΩ- cm please call and speak to an applications engineer for additional information.	Filtered water*  0 - 50% Laboratory Grade Ethylene Glycol/Water*  0 - 50% Laboratory Grade Propylene Glycol/Water*  * Chillers with P1/P2 pumps to 88°C, T9 pump to 82°C, all other pumps to 90°C (when fluid properly maintained)



Ethylene glycol (EG) is poisonous and flammable. Before using any fluid or performing maintenance where contact with the fluid is likely refer to the manufacturer's SDS for handling precautions. ▲



EG is also hygroscopic, it absorbs water from its environment. This can affect the freezing point and boiling point of the fluid over time and may result in system failure. ▲



To prevent freezing/glazing of the plate exchanger, all ThermoFlex7500 and 24000s require the use of 50/50 EG/water or 50/50 PG/water below 10°C process temperature. ▲



When using a process fluid mixture of ethylene glycol and water or propylene glycol and water, check the fluid concentration and pH on a regular basis. Changes in concentration and pH can impact system performance. ▲



When using EG/water or PG/water, top-off with plain water. After top-off check the fluid concentration. ▲



Do not use a Deionization (DI) filter cartridge with Inhibited EG or Inhibited PG. A DI filter will remove inhibitors from the solution rendering the fluid ineffective against corrosion protection. Also, inhibitors increase fluid conductivity. ▲

## Compatibility with Approved Fluids

### Filtered Tap Water/Single Distilled Water

Filtered drinking water and single distilled water are good choices for use in a recirculating chiller because the filtering/distilling process used removes microorganisms that could create biological fouling as well as harmful particulates and excessive minerals that could cause harmful deposits and scaling.

### Chlorine

Short term usage of tap water may not cause any adverse affects on the chiller or your application, but in the long term problems may arise. To help alleviate these problems Thermo Fisher Scientific recommends the use of chlorine.

The duration of time that chlorine remains in solution depends on factors such as water temperature, pH and availability of direct sunlight. We recommend maintaining chlorine levels at proper levels using chlorine test strips, generally 1 to 5 ppm is adequate.

For best results, maintain the pH of the fluid between 6.5 and 7.5. Do not add additional chlorine without first determining the concentration ratio that already exists in the fluid supply. Corrosion and degradation of the circulation components can result from concentration ratios that are too high. Contact our customer support for additional information.

### Deionized Water

Deionized water is water that has had its mineral ions removed using ion exchange resins. The purpose of this process is to remove the ions that allow electrical current to flow more easily through water. This helps to prevent electrical leaks to ground through the recirculating fluid. Deionized water is classified by the electrical resistance of the water, usually measured in M $\Omega$ -cm, with pure water having a resistance of 18 M $\Omega$ -cm.

Deionized water is in an unbalanced state and will leach the missing ions from the materials it comes in contact with. The aggressive nature of this leaching can cause pitting on metal surfaces. Note that the deionizing process does not remove microorganisms. Because of this, we recommend deionized water only with applications that have it as a specified requirement.

In any case, only deionized water with a 1 - 3 M $\Omega$ -cm resistivity is approved for use in Thermo Fisher Scientific recirculating chillers. For applications requiring resistivity greater than 1 M $\Omega$ - cm please call and speak to an applications engineer for additional information.

### Recommended Biocides and Inhibitors

Thermo Fisher Scientific offers a biocide and inhibitor package Thermo 200 (NALCO) premixed with 5 gallons of water or as a kit to be added to water. No other biocide or inhibitor is recommended for use in our chillers.



**Biocides are corrosive and can cause irreversible eye damage and skin burns. They are harmful if inhaled, swallowed or absorbed through the skin. Refer to the manufacturer's most current SDS. ▲**



To prevent freezing/glazing of the plate exchanger, ThermoFlex7500 and 24000 chillers require the use of 50/50 EG/water or 50/50 PG/water below 10°C process temperature. ▲

#### **Uninhibited Ethylene Glycol/Water**

Ethylene glycol is used to depress the freezing point of water and should only be used at temperatures where freeze point suppression is required. Ethylene glycol does not improve heat transfer and is not recommended for use as a biocide. Because glycols lower the surface tension of water and do not evaporate as readily as water, they may cause visible weepage past the pump seals. If weepage cannot be tolerated use seal-less, magnetically driven pumps where available.

Uninhibited simply means that the glycol does not contain any additives to prevent corrosion. While uninhibited ethylene glycol is acceptable for use, the pH level must be closely monitored and the fluid may need to be replaced more often. Since all glycols produce acids in the presence of air and the fluid change the glycol if the pH falls below 8. Note that litmus paper will not work to test the pH of ethylene glycol/water.

#### **Inhibited Ethylene Glycol/Water**

Inhibited glycol can help protect the wetted metals within the cooling circuit from corrosion caused by poor water quality, ethylene glycol oxidation (low pH) and mixed metals (electrolysis). The inhibitor works by either leaving a barrier coating on metal surfaces to buffer them from the corrosive fluid or by creating an oxidized layer that protects the underlying metal (passivating).

Inhibited automotive glycols are never acceptable. They use either silicates or Organic Acid Technology (OAT) as the inhibitor and these components are not compatible with the polymers used in recirculating chillers including the pump seals and internal hoses.

Inhibitors may also accelerate pump seal wear and seal-less, use magnetically driven pumps where available.

#### **Uninhibited Propylene Glycol/Water**

Propylene glycol does not transfer heat as well as ethylene glycol, but can be used when freeze point suppression is required as well as lower toxicity.

Propylene glycol does not function as a biocide and the pH needs to be maintained the same as with ethylene glycol as it also produces acid when oxidized.

#### **Inhibited Propylene Glycol/Water**

Inhibited propylene glycol has the same properties as uninhibited propylene glycol and the same concerns as inhibited ethylene glycol.

## Additional Fluid Information

When using the ThermoFlex chiller to circulate through aluminum, use a compatible corrosion inhibitor to prevent galvanic corrosion.

Ensure fluid viscosity is 50 cSt or less at the lowest temperature used.

Visible pump weepage may occur when compatible glycols, oils or other additives are used. Pump weepage is considered as a normal operating condition of mechanical seal pumps.

## Process Water Quality and Standards

Process Fluid	Permissible (PPM)	Desirable (PPM)
<b>Microbiologicals</b>		
(algae, bacteria, fungi)	0	0
<b>Inorganic Chemicals</b>		
Calcium	<25	<0.6
Chloride	<25	<10
Copper	<1.3	<1.0
	0.020 ppm if fluid in contact with aluminum	
Iron	<0.3	<0.1
Lead	<0.015	0
Magnesium	<12	<0.1
Manganese	<0.05	<0.03
Nitrates/Nitrites	<10 as N	0
Potassium	<20	<0.3
Silicate	<25	<1.0
Sodium	<20	<0.3
Sulfate	<25	<1
Hardness	<17	<0.05
Total Dissolved Solids	<50	<10
<b>Other Parameters</b>		
pH	6.5-8.5	7-8
Resistivity	0.01*	0.05-0.1*

\* MΩ-cm (compensated to 25°C)

Unfavorably high total ionized solids (TIS) can accelerate the rate of galvanic corrosion. These contaminants can function as electrolytes which increase the potential for galvanic cell corrosion and lead to localized corrosion such as pitting. Pitting may become so extensive that it causes a breach in the cooling system resulting in a refrigerant leak into the fluid system.

As an example, raw water in the United States averages 171 ppm (of NaCl). The recommended level for use in a water system is between 0.5 to 5.0 ppm (of NaCl).

Recommendation: Initially fill the reservoir with distilled or 1-3 MΩ-cm deionized water. (It is acceptable to have the fluid drop to the other levels over-time.) Do not use untreated tap water as the total ionized solids level may be too high. This will reduce the electrolytic potential of the water and prevent or reduce the galvanic corrosion observed.

## Facility Water Quality and Standards (water-cooled chillers)

Facility Water	Permissible (PPM)	Desirable (PPM)
<b>Microbiologicals</b> (algae, bacteria, fungi)	0	0
<b>Inorganic Chemicals</b>		
Calcium	<40	<0.6
Chloride	<250	<25
Copper	<1.3 0.020 ppm if fluid in contact with aluminum	<1.0
Iron	<0.3	<0.1
Lead	<0.015	0
Magnesium	<12	<0.1
Manganese	<0.05	<0.03
Nitrates\Nitrites	<10 as N	0
Potassium	<20	<0.3
Silicate	<25	<1.0
Sodium	<20	<0.3
Sulfate	<250	<50
Hardness	<17	<0.05
Total Dissolved Solids	<50	<10

**Note** A corrosion inhibitor is recommended if mixed metals are in the facility water loop. ▲



# Facility Water Requirements (water-cooled chillers)



Facility Water Maximum Inlet Pressure must not exceed 150 PSIG.

Facility Water Maximum Pressure Differential must not exceed 50 PSID.  
(Pressure Differential = Inlet Pressure - Outlet Pressure)

Contact us before using facility water that is above 35°C.

The facility water must meet the following conditions for the chillers to maintain their full rated capacity.

**ThermoFlex1400**

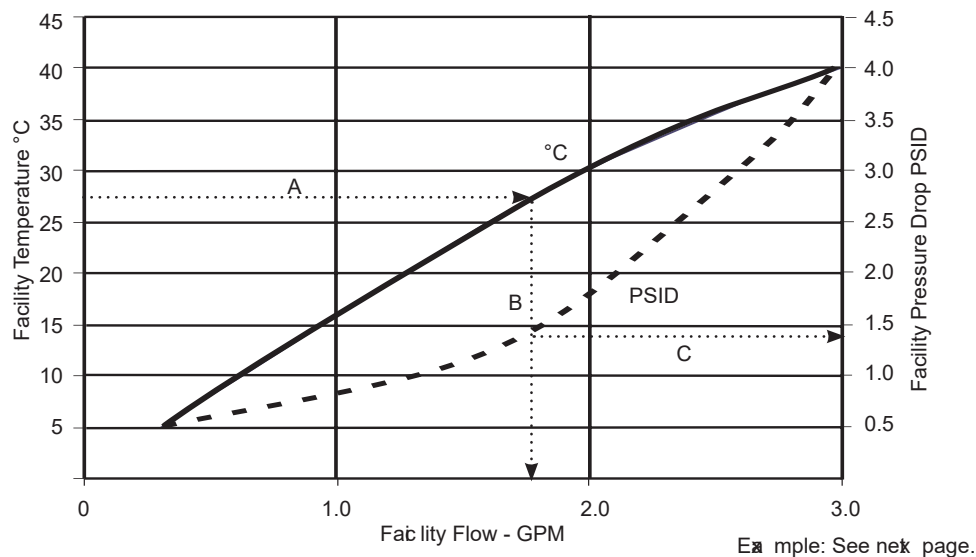

**ThermoFlex2500**

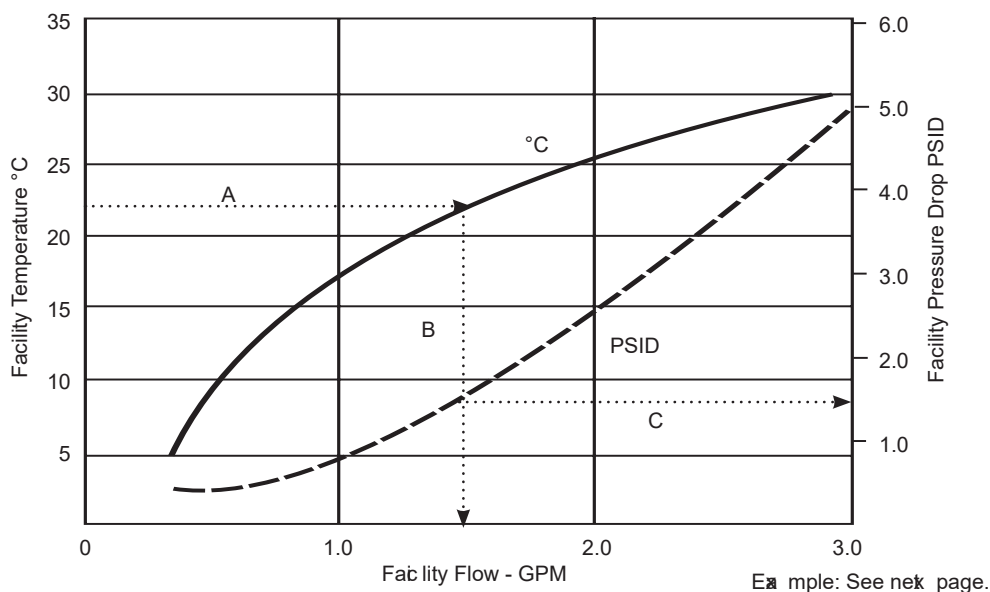

**ThermoFlex3500/5000**

The facility water must meet the following conditions for the chillers to maintain their full rated capacity.

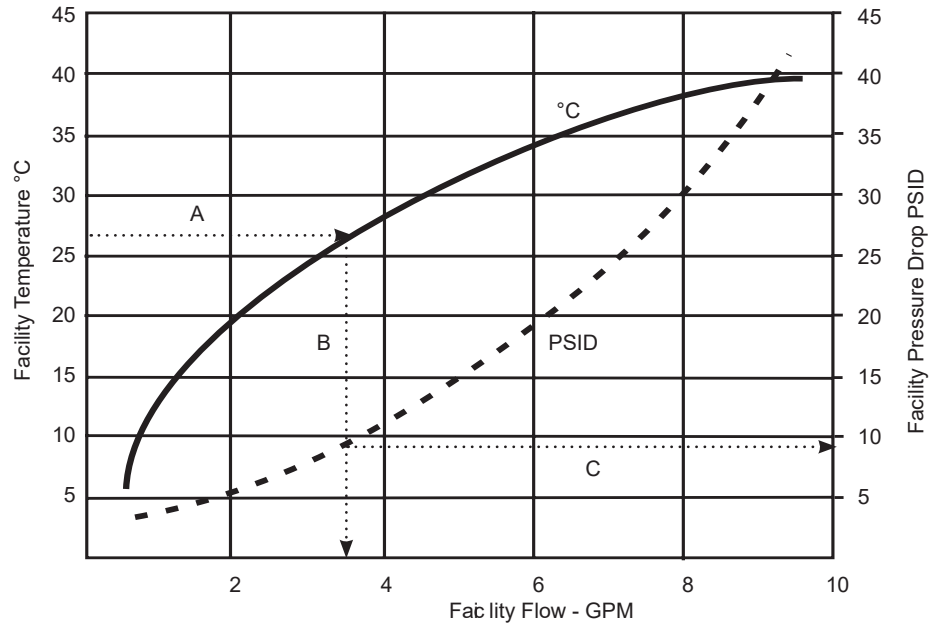

Example: See below.

**ThermoFlex7500/10000**

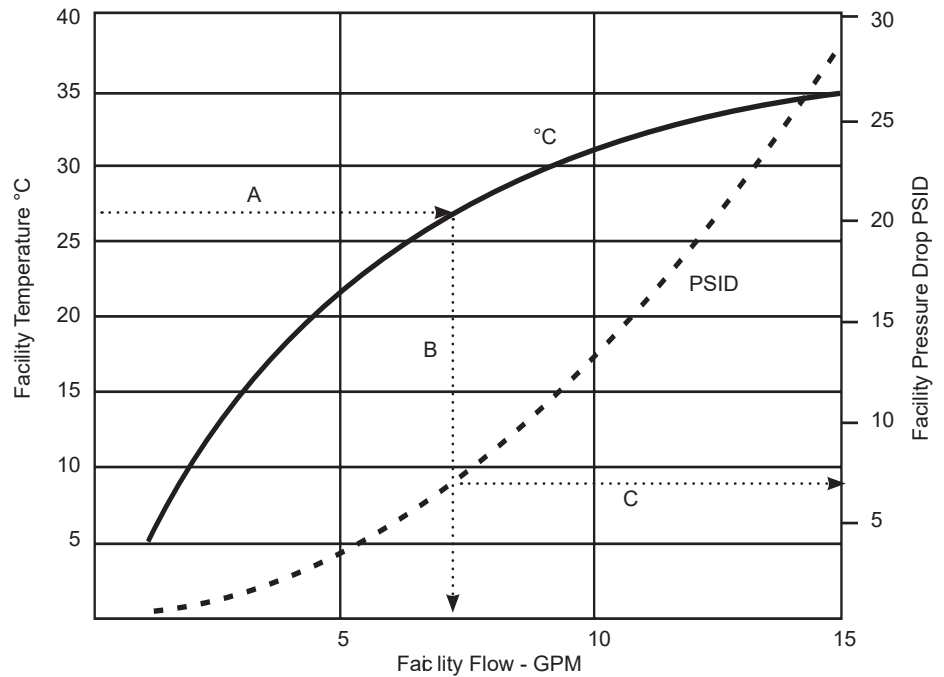

Example:

Follow the ..... lines

Start with a known, e.g., facility water temperature.

A - go across to temperature curve

B - drop down to determine the minimum required facility flow.

C - Where B crosses the PSID curve, go across to determine the minimum required PSID.

**ThermoFlex24000**

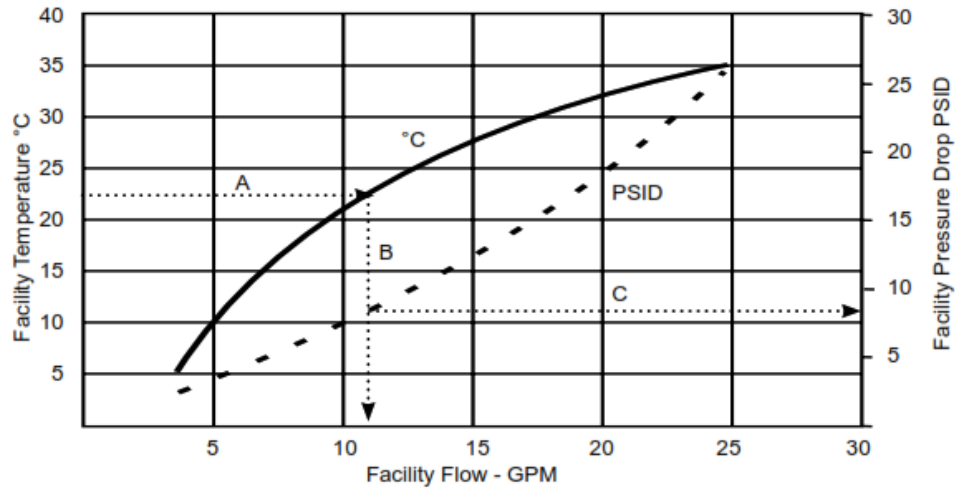

## Fluid Filter Bag

The reservoir has a fluid bag filter designed to prevent the introduction of particulates into the system.



**Install the filter bag before starting the chiller. ▲**

Place your fingers below the front of the housing and push up on the housing to remove it.



Install the bag.

Replace the housing. Slide its back edge under the lip of the chiller's top panel and then press down until the housing snaps into place.

**Figure 3-6** Fluid Filter Bag

## Priming

If able, pre-fill the process fluid lines. The chiller is designed to shut down if not properly primed.

Ensure that there is enough fluid prepared to fill both the chiller and your application. If able, pre-fill the process fluid lines to reduce the setup time.

Fill the reservoir to the max fill line on the reservoir sight tube. To prevent the introduction of particulates into the system, fill the chiller with the reservoir bag filter in place.

Start the chiller using the power button  on the control panel.

As the pump fills your application add fluid to the reservoir to maintain the fluid level.

Repeat this process until the fluid level no longer drops in the reservoir.

If you need to pause priming use the power button to turn the chiller off.



**Not completely filling the chiller and process fluid lines could damage the chiller's pump. ▲**

## Initial Filling Requirements



Ensure the reservoir drain plug on the back of the chiller is in place, or the Riton fitting is closed, and that all plumbing connections are secure.

Before using any fluid refer to the manufacturer's SDS for handling precautions. ▲

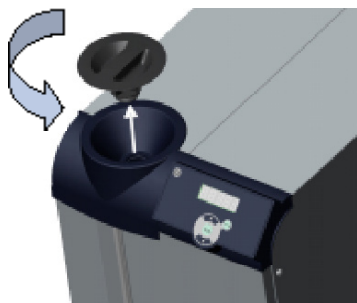

Locate and remove the reservoir cap by unscrewing it counterclockwise.

To prevent the introduction of particulates into the system, fill with the reservoir bag filter in place.

**Figure 3-7** Reservoir Cap

The reservoir has a sight tube and ball for easy fluid level monitoring. *Slowly* fill the reservoir with clean process fluid through the funnel only, failure to comply may result in internal spillage.

**Note** Filling the reservoir above MAX LEVEL fill line will result in a over flow error (**Over Flow**) causing the chiller to shut down. Also, fluids expand when heated. ▲

Since the reservoir capacity may be small compared to your application and air may need to be purged from the lines, have extra cooling fluid on hand to keep the system topped off when external circulation is started.

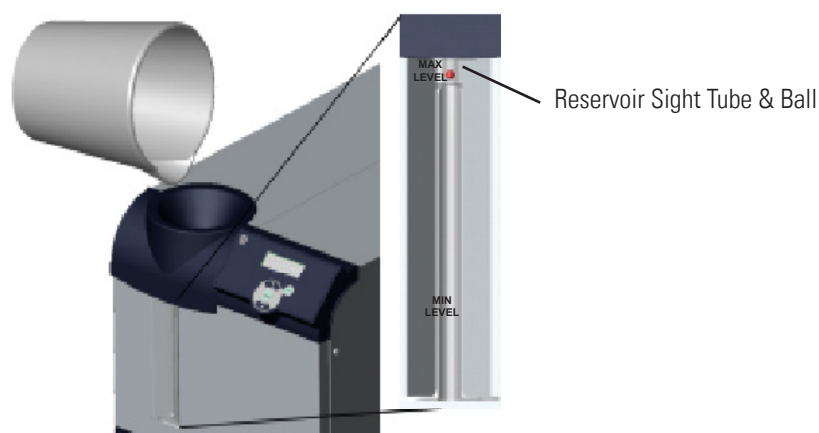

**Figure 3-8** Reservoir Sight Tube & Ball



Before replacing the reservoir cap ensure the reservoir sight tube ball stopper is securely in place. ▲

Replace the reservoir cap by screwing it clockwise. Cap should be hand tight.

## Fluid Top Off



Ensure the reservoir cap is at a safe handling temperature before removing. ▲

Remove the reservoir cap by unscrewing it counterclockwise.

To prevent the introduction of particulates into the system, fill the chiller with the reservoir bag filter in place.

The reservoir has a sight tube and ball for easy fluid level monitoring. *Slowly* fill the reservoir with clean process fluid through the funnel only, failure to comply may result in internal spillage.

**Note** Filling the reservoir above MAX LEVEL fill line will result in a over flow error (**Over Flow**) causing the chiller to shut down. Also, fluids expand when heated. ▲

**Note** Adding fluid that has a temperature differential with the fluid already in the reservoir will temporarily affect the chiller's stability performance. ▲



Before replacing the reservoir cap ensure the reservoir sight tube ball stopper is securely in place. ▲

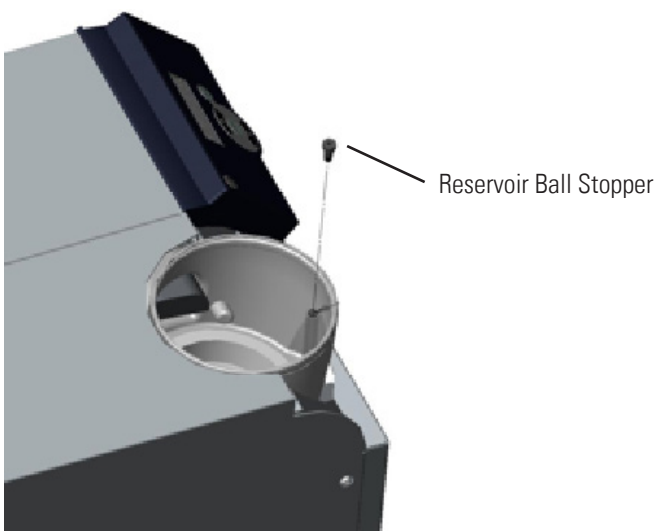

**Figure 3-9** Reservoir Ball Stopper



## Section 4 Operation

### Deluxe Controller

The controller changes temperature using a Proportional-Integral-Derivative (PID) algorithm, and is designed with easy to use operator interface.

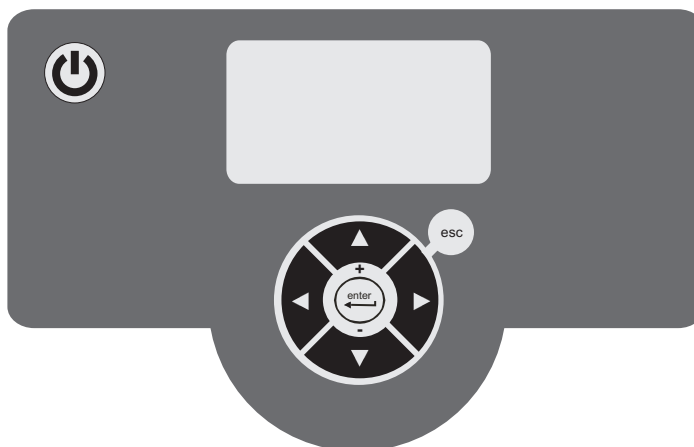

**Figure 4-1** Deluxe Controller



Press this button to start and stop the chiller.



Press this button to navigate through the controller displays and to increase adjustable values.



Press this button to navigate through the displays and to decrease adjustable values.



Press these buttons to navigate through the displays.



This button has four functions. Pressing it once allows changes to be made to the display, pressing it again saves the change and allows you to continue to other displays. It is also pressed to clear messages.

Depressing and holding the enter button for two seconds before starting the chiller allows you to view and to make changes to the controller settings.

esc

Press this button to abort any changes and at the same time return the controller to its previous display. Aborting a change can only be made *before* the change is saved.

## Initial Start Up Only

- Place the circuit protector located on the rear of the chiller to the up position.
- Press the  button on the controller.

The controller will display the quick start screen that will allow you to configure the chiller. Refer to the Quick Start Guide supplied with the chiller or the copy located after the Table of Contents.

Press the arrows to scroll through and highlight each line of the display. If a change is needed from the factory default value press the enter button.



**If the auto restart is enabled and the chiller shuts down as a result of a power failure, when power is restored the chiller will automatically restart and operate at the saved values. Consider any possible risks before enabling this mode of operation. ▲**

**Note** The chiller will not automatically restart if the **Show Quick Start** was enabled, see page 4-20. In this case only the controller is powered. ▲

If satisfied with all the entries, press enter when the last line - **Quick Start Done** - is highlighted. If not satisfied, press the left arrow, or esc button, to leave the quick start display.

In either case the screen will go blank.

If enter was pressed, press  to bring up the **Daily Start Up** displays and start the chiller. See next page.

## Daily Start Up

Before starting the chiller, double check all electrical and plumbing connections. Have extra recirculating fluid on hand. If the chiller will not start refer to Section 7 Troubleshooting.

Do not run the chiller until fluid is added.



Ensure the chiller's castors are locked. ▲

- Ensure the circuit protector located on the rear of the chiller is in the up position.
- Press  on the controller, the pump and the refrigeration system will automatically start.

The controller automatically sequences through the following displays:

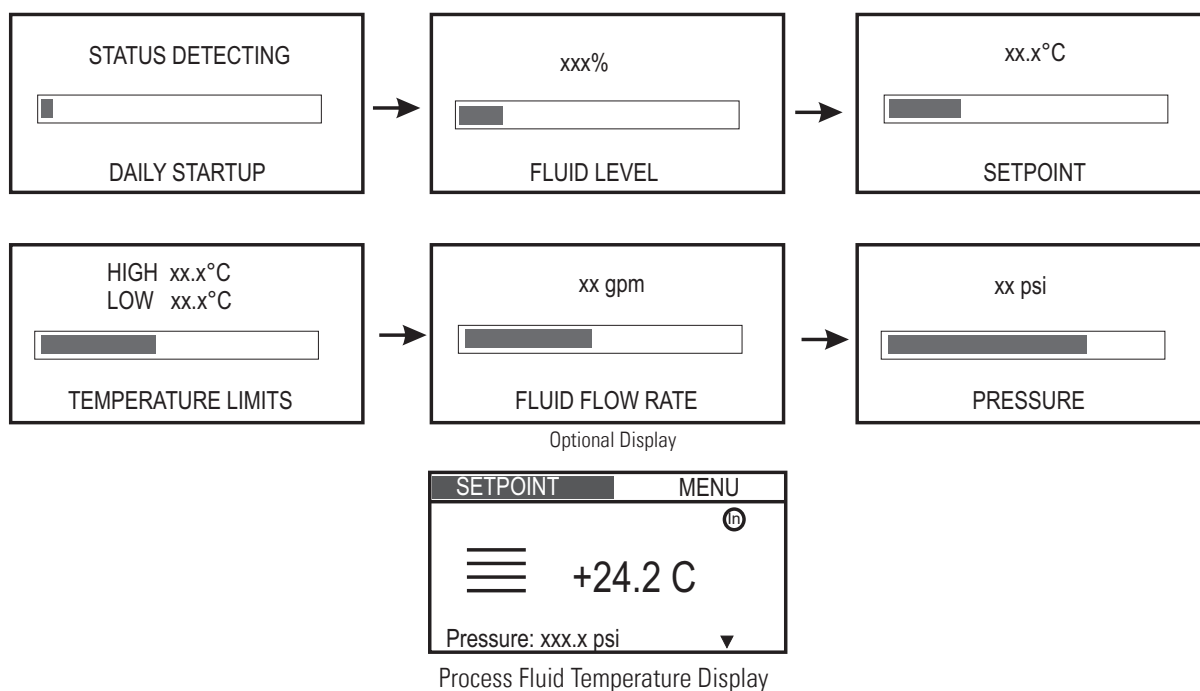

**Figure 4-2** Daily Start Up Displays

If **Level %** is not displayed on the bottom of the screen refer to Status Displays in this section.

If the fluid level is above the required minimum value, see next page, the pump and compressor will automatically start but only after a 30 second delay.

If the fluid level is at or below the value, see next page, fluid will need to be added before the compressor will start, see **Initial Fill Mode** on next page. After start up, check the plumbing connections for leaks.

## Initial Fill Mode

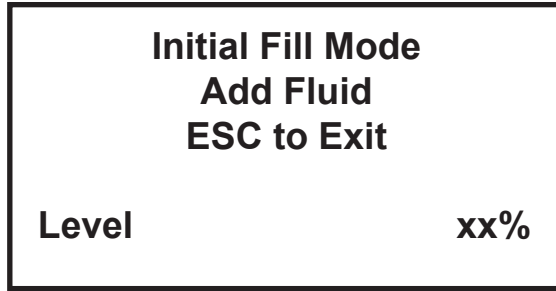

- Press  on the controller.

If the **Initial Fill Mode** message appears the chiller needs fluid before it will start.

Required minimum level values depend on the chiller's heater size, see below.

If the **Level** is below the required amount **Add Fluid** will be displayed and flash until the required level is achieved, then **Add Fluid** will extinguish.

For all chillers, the pump will not start until the level is above **15%**. Once the level is above the required amount for five minutes, as the pump purges the system, the chiller will start.

If desired, press  to exit the initial fill mode and start the compressor.

**Note** The chiller can be turned ON/OFF using the ACOM and DCOM option in the **Initial Fill Mode**.

Heater	Required Minimum Level
None	15%
1 kW:	58%
2.3 kW:	64 or 58% (depending on chiller configuration)
5.0 kW:	87%
4.6 kW:	87%

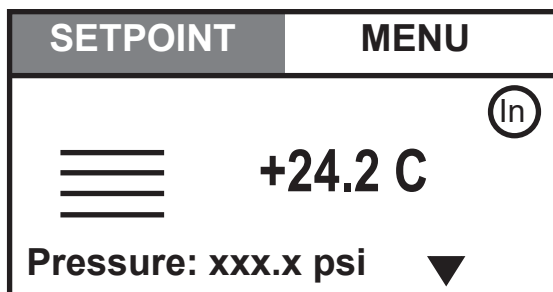

## Process Fluid Temperature Display





**Figure 4-3** Process Fluid Temperature Display

The **SETPOINT** and **MENU** portions on the top of the display are used to view and/or change the controller's settings. They are explained in detail later in this Section.

The bars on the left of the display indicate the chiller's operating status.

-  Indicates the chiller is either not running or the ThermoFlex is at the desired setpoint.
-  Indicates the chiller is heating up to the setpoint.
-  Indicates the chiller is cooling down to the setpoint.

The small circle indicates which sensor is controlling the chiller.

-  When displayed, indicates the ThermoFlex is responding to the chiller's internal temperature sensor.
-  When displayed, indicates the ThermoFlex is responding to an external temperature sensor. See **Analog Comm - ACOM** in this Section to enable the external sensor.

The chiller is always in internal or external control. The default setting is internal.

The temperature displayed is the current process fluid temperature.

The message on the bottom is used to display the chiller's operational status. The status displays are explained later in this Section.

# SETPOINT

**Note** Depressing and holding the enter button for two seconds before starting the chiller allows you to view, as well as make changes to, the setpoint. ▲

Press the arrows to highlight **SETPOINT**.

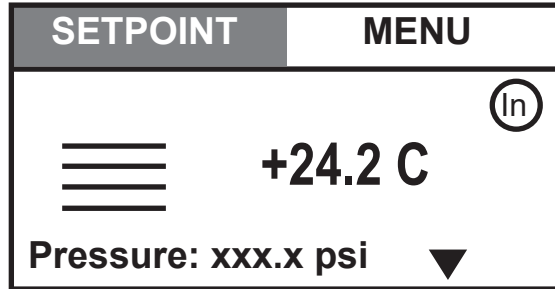

Press enter and the setpoint value appears. If needed, press enter again and the value starts flashing indicating the setpoint can be changed.

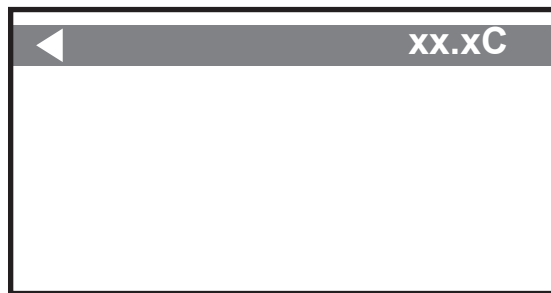

The setpoint range for standard temperature chillers is +5°C to +40°C, the range for high temperature chillers is +5°C to +90°C. For ThermoFlex 24000 the setpoint range is -5°C to +90°C. Press the up and down arrows to change the setpoint to the desired value.

Once the desired value is displayed press the enter button again to accept the change and to stop the flashing.

Return to the Process Fluid Temperature Display by pressing the left arrow or esc button.

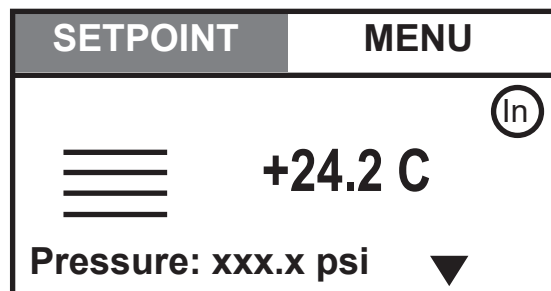



## Status Displays

The controller can show up to four different messages. Press the down arrow to highlight the bottom of the display.

Press enter to get the displayed message to flash.

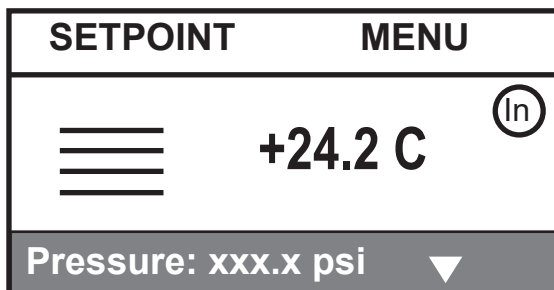

Press the arrows to scroll through the available displays. Once the desired display is showing press enter again.

### Available Displays:

**Pressure:** Indicates pump discharge pressure

**Level %:** Indicates reservoir fluid level

**Flow:** Indicates the process fluid flow rate (Optional)

**Resistivity:** Indicates the process fluid resistivity level (Optional)

The arrow at the end of the display indicates which direction you can scroll to get to another display. A ▼ means you can only scroll down to the next display. A ▲ means you can only scroll up to the next display. ▲▼ means you can scroll up or down.

# MENU Displays

The ThermoFlex controller uses menus to view/change the controller's settings.

**Note** Depressing and holding the enter button for two seconds before starting the chiller allows you to view and to make changes to the settings. ▲

1. Press the arrows to highlight MENU.

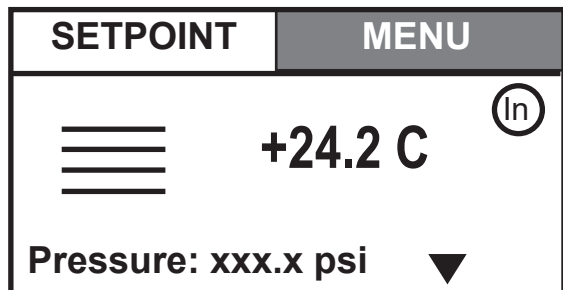

2. The controller brings up the Main Menu Display.

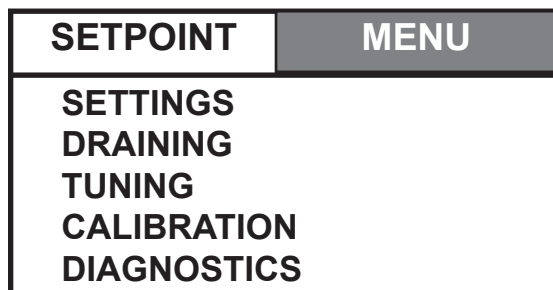

Main Menu Display

3. Press the up and down arrows to highlight the desired option.

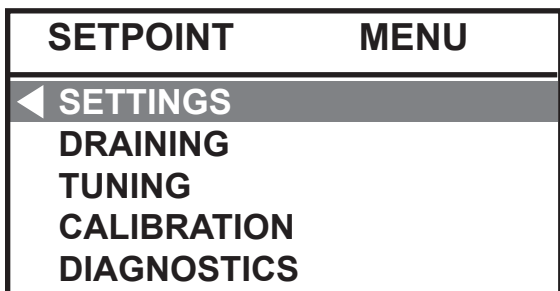

4. With the desired option highlighted, press enter to display sub-menus.

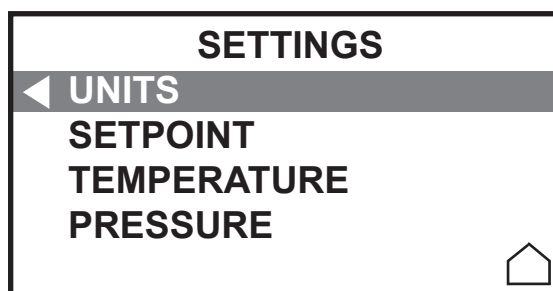

5. There are various ways to navigate through all the menu options.

6. In the example in step 5, pressing the left arrow, or the esc button, on the controller will return you to the previous display.

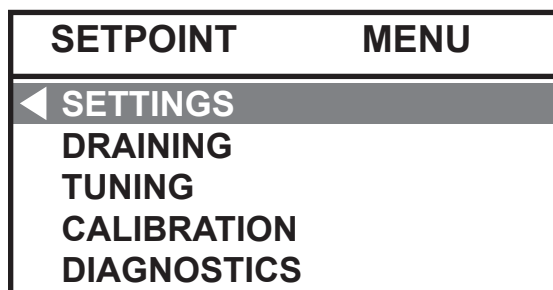
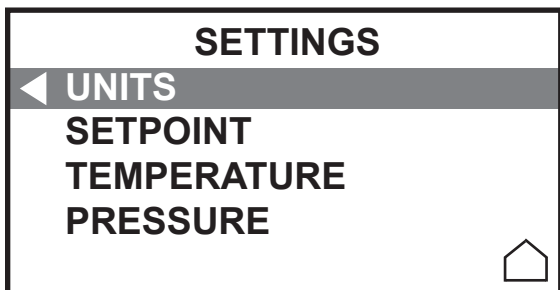

7. Or, highlight the home icon at the bottom of the display.

8. Then press enter to return to the Main Menu Display.

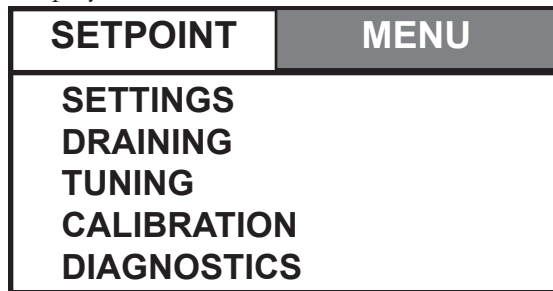
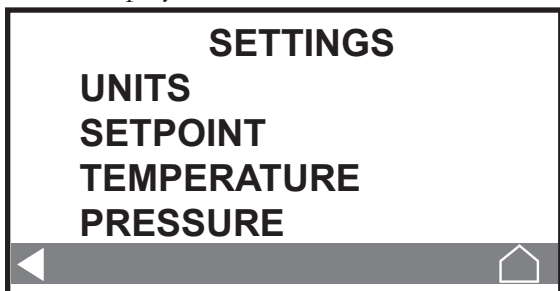

## Main Menu Tree

**Note** The controller can only display six lines at a time. Press the up and down arrows to scroll through and highlight each line. ▲

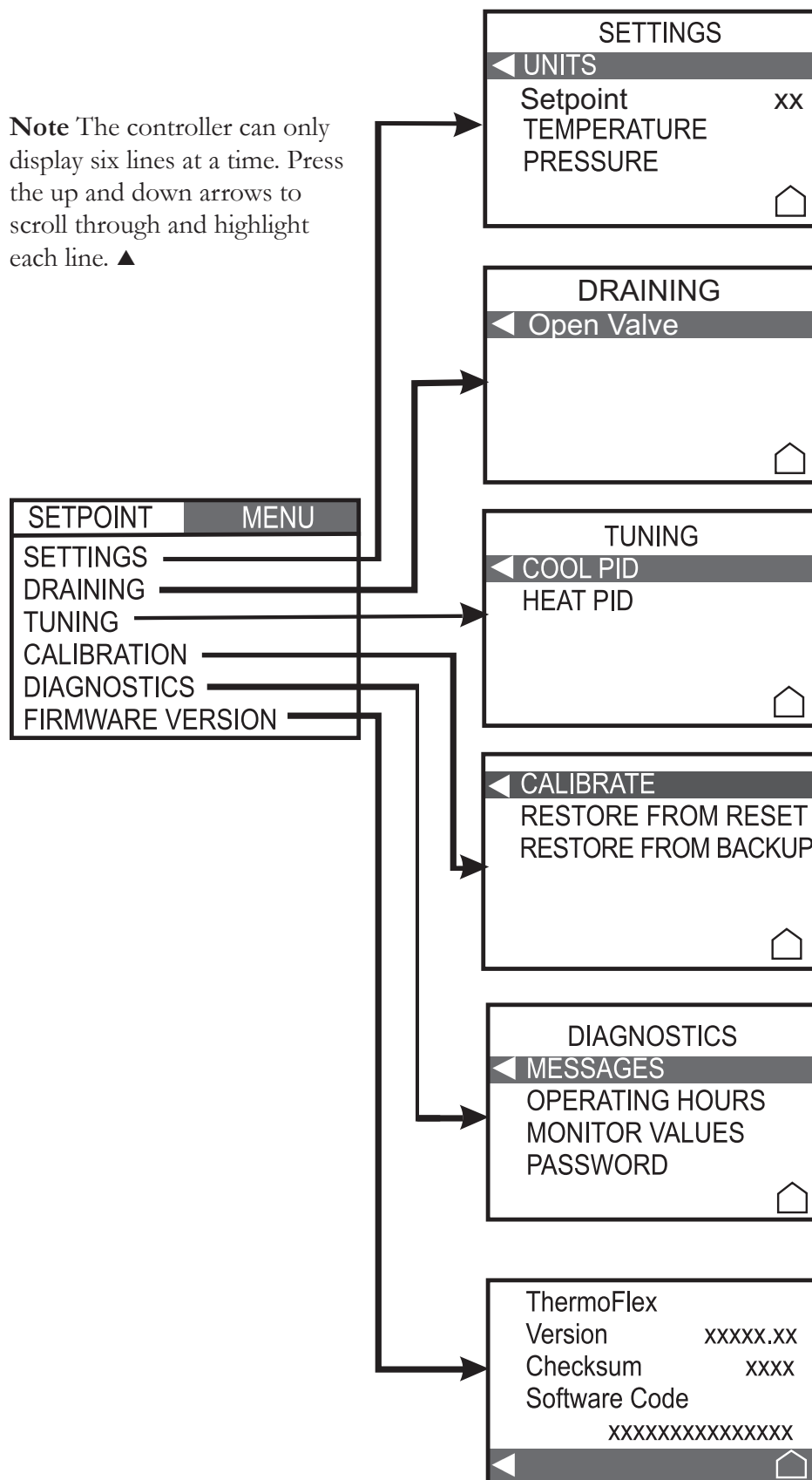

**SETTINGS** allows you to view/change settings, see page.

**DRAINING** opens/closes the optional anti drainback valve, see page 4-20.

**TUNING** allows you to view/change the controller's **PID** values, see Section 7.

**CALIBRATE** calibrates the chiller's temperature, pressure and optional fluid flow sensors, see Section 8.

**DIAGNOSTICS** is used to display alarm messages, see Section 7, and also to display the chiller, filter and optional DI cartridge operating hours, see Section 6. **MONITOR VALUES** and **PASSWORD** are used only by qualified technicians.

**FIRMWARE VERSION** is used to display the controller's firmware information. Press the esc button to return to the Main Menu Display.

# SETTINGS Menu Tree

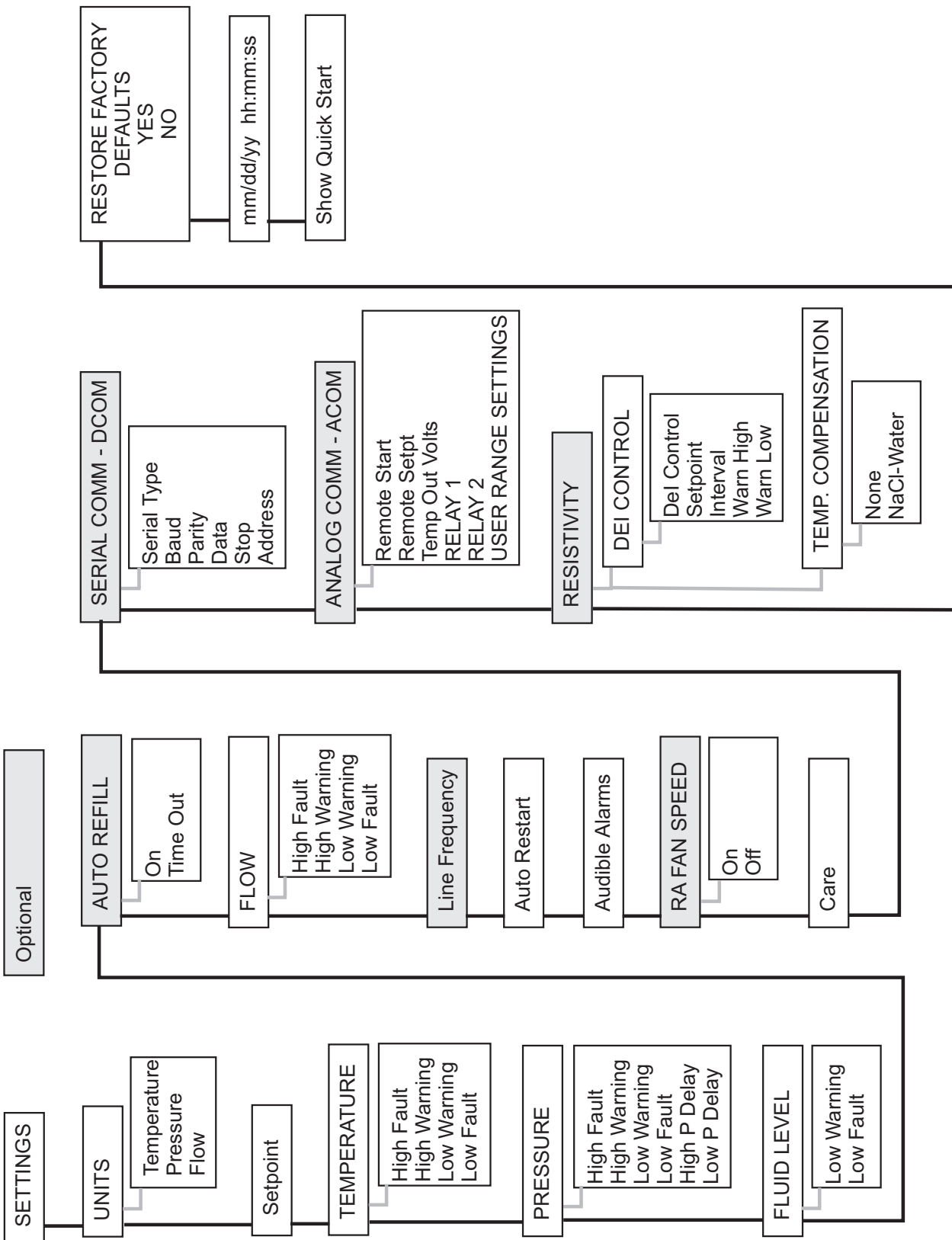

## SETTINGS

**SETTINGS** allows you to view/change settings.

**Note** The controller can only display six lines at a time. Press the up and down arrows to scroll through and highlight each line. ▲

If a change to a setting is needed, highlight the desired line and then press the enter button. The highlight will start to flash.

If the text on a line is all capital letters, e.g., **UNITS** and **TEMPERATURE**, the setting has a sub-menu. Pressing enter will bring up the sub-menu. The sub-menus, shown on the following pages, allow you to view/change the applicable settings.

Lines that are not all capital, e.g., **Setpoint** and **Line Frequency**, indicate the changes can be made directly on the **SETTINGS** display.

If the line has a box, **Auto Restart**, pressing enter with that line highlighted will toggle between on or off. See **Auto Restart** in this section for precautions and additional details.

SETTINGS	
◀	<b>UNITS</b>
<b>Setpoint</b>	<b>xx</b>
<b>TEMPERATURE</b>	
<b>PRESSURE</b>	
	
-----	
<b>FLUID LEVEL</b>	
<b>AUTO REFILL*</b>	
<b>FLOW*</b>	
<b>Line Frequency*</b>	<b>60HZ</b>
<input type="checkbox"/> <b>Auto Restart</b>	
<input type="checkbox"/> <b>Audible Alarms</b>	
<b>RA FAN SPEED MODE*</b>	
<b>Care Level</b>	<b>off</b>
<b>SERIAL COMM - DCOM*</b>	
<b>ANALOG COMM - ACOM*</b>	
<b>RESISTIVITY*</b>	
<b>RESTORE DEFAULTS</b>	
<b>mm/dd/yy</b>	<b>hh:mm:ss</b>
<input type="checkbox"/> <b>Show Quick Start</b>	

\*Only dip lags on billers equipped with the option.

# UNITS

**UNITS** is used to view/change the controller's temperature, pressure and fluid flow (only chillers with an optional flow transducer) scales.

If a change to the setting is needed, highlight the desired scale and then press the enter button. The highlight will flash. Press the up or down arrow button to bring up the desired scale. Once the desired scale is displayed press enter to accept the change and stop the flashing.

When the desired changes are made press the left arrow, or esc button, to return to the **SETTINGS** display.

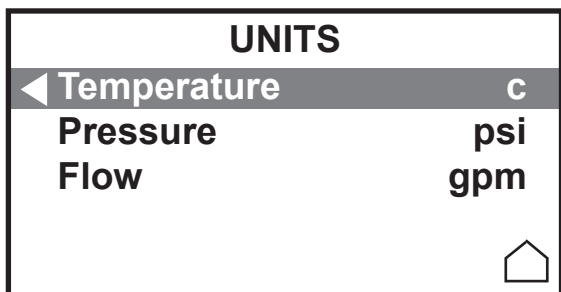

Scales: °C or °F  
 PSI, Bar or kPa  
 GPM or LPM

Defaults: °C  
 PSI  
 GPM

# Setpoint

**Setpoint** can be used to view/change the controller's setpoint temperature.

If a change to the setpoint is needed, highlight **Setpoint** and then press the enter button. The highlight will flash. Press the up or down arrow to bring up the desired setpoint value. Once the desired value is displayed press enter to accept the change and stop the flashing.

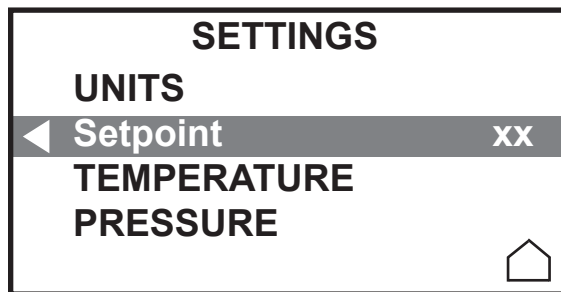

**Setpoint Range:**  
 +5°C to +40°C for standard temperature chillers  
 +5°C to +90°C for high temperature chillers,  
 +5°C to +88°C for P1 and P2 high temp chillers  
 -5°C to +90°C\* for ThermoFlex 24000  
 \*82°C with T9 pump

**Setpoint Default:**  
 +20°C for all chillers



## TEMPERATURE

**TEMPERATURE** is used to view/change the chiller's high and low temperature fault and warning settings. If the chiller exceeds the fault setting it will shut down, the controller will display a fault message and, if enabled, sound the alarm. If the chiller exceeds the warning setting the chiller will continue to run, the controller will display a warning message and, if enabled, sound the alarm.

If a change is needed, press the arrows to highlight the desired setting and then press the enter button. The highlight will flash. Press the up or down arrow to change the value. Once the desired setting is displayed press enter to accept the change and stop the flashing.

**Note** You cannot set the **High Warning** value higher than the **High Fault** value. You cannot set the **Low Warning** value lower than the **Low Fault** value. ▲

When the desired changes are made press the left arrow, or esc button, to return to the **SETTINGS** display.

TEMPERATURE	
◀High Fault	xxC
High Warning	xxC
Low Warning	xxC
Low Fault	xxC

### High Fault/Warning Range:

**+2°C to +43°C** for standard temperature chillers

**+2°C to +93°C** for high temperature chillers

**-7°C to +93°C** for ThermoFlex24000

### High Fault/Warning Default:

**+42°C** for standard temperature chillers

**+92°C** for high temperature chillers and ThermoFlex24000

### Low Fault/Warning Range:

**+2°C to +43°C** for standard and

high temperature chillers

**-8°C to +93°C** for ThermoFlex24000

### Low Fault/Warning Default:

**+3°C** for standard and high temperature chillers

**-8°C** for ThermoFlex24000

# PRESSURE

**PRESSURE** is used to view/change the chiller's high and low pressure fault and warning settings and set a delay time. If the chiller exceeds the fault setting it will shut down, the controller will display a fault message and, if enabled, sound the alarm. If the chiller exceeds the warning setting the chiller will continue to run, the controller will display a warning message and, if enabled, sound the alarm. The delay sets the length of time needed after a pressure fault before the chiller shuts down.

**Note** Since the controller can only display six lines at a time, keep pressing the down arrow until the **High P Delay** and **Low P Delay** lines are visible. ▲

If a change to the setting is needed, press the arrows to highlight the desired pressure and then press the enter button. The highlight will flash. Press the up or down arrow to change the value. Once the desired setting is displayed press enter to accept the change and stop the flashing.

**Note** You cannot set the **High Warning** value higher than the **High Fault** value. You cannot set the **Low Warning** value lower than the **Low Fault** value. ▲

When the desired changes are made press the left arrow, or esc button, to return to the **SETTINGS** display.

PRESSURE	
◀ High Fault	xxpsi
High Warning	xxpsi
Low Warning	xxpsi
Low Fault	xxpsi
	⏠
High P Delay	xsec
Low P Delay	xsec

### High/Low Fault/Warning Range:

Pump dependent - see below

### High/Low Pressure Time Delay Range:

0 to 30 seconds (0 to 60 for P3,P5,T9 pumps)

### High Time Pressure Delay Default:

0 seconds (60 seconds for P3,P5,T9 pumps)

### Low Time Pressure Delay Default:

10 seconds

Pump	Fault Range	High Default	Low Default
P1 P2 T0 T1:	3 to 105 PSI	105 PSI	3 PSI
P3 60 Hz	3 to 46 PSI	46 PSI	3 PSI
P3 50 Hz	3 to 32 PSI	32 PSI	3 PSI
P4 60 Hz	3 to 85 PSI	85 PSI	3 PSI
P4 50 Hz	3 to 60 PSI	60 PSI	3 PSI
P5 60 Hz	3 to 87 PSI	87 PSI	3 PSI
P5 50 Hz	3 to 56 PSI	56 PSI	3 PSI
T5 60 Hz	2 to 105 PSI	105 PSI	2 PSI
T5 50 Hz	2 to 105 PSI	105 PSI	2 PSI
T9:	3 to 105 PSI	105 PSI	3 PSI
Pump	Warning Range	High Default	Low Default
P1 P2 T0 T1:	4 to 100 PSI	100 PSI	4 PSI
P3 60 Hz	4 to 46 PSI	46 PSI	4 PSI
P3 50 Hz	4 to 32 PSI	32 PSI	4 PSI
P4 60 Hz	4 to 85 PSI	85 PSI	4 PSI
P4 50 Hz	4 to 60 PSI	60 PSI	4 PSI
P5 60 Hz	4 to 87 PSI	87 PSI	4 PSI
P5 50 Hz	4 to 56 PSI	56 PSI	4 PSI
T5 60 Hz	4 to 105 PSI	105 PSI	4 PSI
T5 50 Hz	4 to 105 PSI	105 PSI	4 PSI
T9:	4 to 105 PSI	105PSI	4 PSI

## FLUID LEVEL

**FLUID LEVEL** is used to view/change the chiller's reservoir level fault and warning settings. If the chiller exceeds the fault setting it will shut down, the controller will display a fault message and, if enabled, sound the alarm. If the chiller exceeds the warning setting the chiller will continue to run, the controller will display a warning message and, if enabled, sound the alarm.

If a change to the setting is needed, press the arrows to highlight the desired line and then press the enter button. The highlight will flash. Press the up or down arrow to change the value. Once the desired setting is displayed press enter to accept the change and stop the flashing.

**Note** You cannot set the **Low Warning** value lower than the **Low Fault** value. ▲

When the desired changes are made press the left arrow, or esc button, to return to the **SETTINGS** display.

FLUID LEVEL	
◀ Low Warning	x%
Low Fault	x%



**Low Warning/Fault Range/Default:**  
Heater dependent - see below

Heater	Warning Range	Default
None	6 - 100%	6%
1 kW:	58 - 100%	58%
2.3 kW:	58 or 69 - 100%	58 or 69%
5.0 kW:	87 - 100%	87%
4.6 kW:	87 - 100%	87%
Heater	Fault Range	Default
None	0 - 100%	0%
1 kW:	52 - 100%	52%
2.3 kW:	63 or 52 - 100%	63 or 52%
5.0 kW:	81 - 100%	81%
4.6 kW:	81 - 100%	81%

## AUTO REFILL (Optional)

**AUTO REFILL** is used to view/change the chiller's optional auto refill settings. **On** is the % of fluid level in the reservoir needed to turn the option on. **Time Out** is the maximum time the option will operate. Setting the time to **0** disables the option.

When the desired changes are made press the left arrow, or esc button, to return to the **SETTINGS** display.

AUTO REFILL	
◀ On	x%
Time Out	xxsec



**On % Default:** Heater dependent - see below

Heater	Range	Default
None	70 - 100%	70%
1 kW:	70 - 100%	70%
2.3 kW:	69 or 70 - 100%	69 or 70%
5.0 kW:	87 - 100%	87%
4.6 kW:	87 - 100%	87%

**Time Out Range:** 0 - 900 seconds

**Time Out Default:** 45 seconds

80 seconds for ThermoFlex7500/10000

Setting the time to **0** disables the option.

## FLOW (Optional)

**FLOW** is used to view/change the chiller's process fluid fault and warning settings. If the chiller exceeds the fault setting it will shut down, the controller will display a fault message and, if enabled, sound the alarm. If the chiller exceeds the warning setting the chiller will continue to run, the controller will display a warning message and, if enabled, sound the alarm.

If a change to the setting is needed, press the arrows to highlight the desired line and then press the enter button. The highlight will flash. Press the up or down arrow button to change the value. Once the desired setting is displayed press enter to accept the change and stop the flashing.

**Note** You cannot set the **High Warning** value higher than the **High Fault** value. You cannot set the **Low Warning** value lower than the **Low Fault** value. ▲

When the desired changes are made press the left arrow, or esc button, to return to the **SETTINGS** display.

FLOW	
◀ High Fault	xxgpm
High Warning	xxgpm
Low Warning	xxgpm
Low Fault	xxgpm

### High/Low Flow Fault/Warning Range/Defaults:

Pump	Range	High/Low Defaults
P1 P2 T1 T0:	0.0 to 10.5 GPM	0.0 GPM
P3 P4 P5:	0.0 to 30.0 GPM	0.0 GPM
T5	0.0 to 15.0 GPM	0.0 GPM
T9	0.0 to 33.5 GPM	0.0 GPM

This feature is not enabled until the value is changed to something other than 0.0. If the feature is not enabled and the low flow rate drops below the flow rate listed below the chiller will continue to run and the controller, if displaying flow, will display **FLow: Low FLOW**.

P1, T0 ,T1, T 5 and T9 Pump	0.3 GPM
P2 Pump	1.0 GPM
P 3, P 4 and P 5 Pump	4.0 GPM

## Line Frequency (Optional)

**Line Frequency** is used to identify the incoming frequency for chillers with a P3 - P5 pump and the capability to run on either **50 Hz** or **60 Hz**. The selected frequency automatically adjusts the firmware's *fixed* high pressure default setting.

Line Frequency		60Hz
<input type="checkbox"/>	Auto Restart	
<input type="checkbox"/>	Audible Alarms	
RA FAN SPEED MODE		
Care Level		off
SERIAL COMM - DCOM		

Frequency Range: **50 Hz** or **60 Hz**

Frequency Default: **60 Hz**

## Auto Restart

**Auto Restart** is used to turn the auto restart feature on/off. The factory default setting is disabled but it may have been enabled using the quick start procedure.



If the auto restart is enabled and the chiller shuts down as a result of a power failure, when power is restored the chiller will automatically restart and operate at the saved values. Consider any possible risks before enabling this mode of operation. ▲

**Note** The chiller will not automatically restart if the **Show Quick Start** was enabled, see page 4-20. In this case only the controller is powered. ▲

<b>Line Frequency</b>	<b>60Hz</b>
<input type="checkbox"/> <b>Auto Restart</b>	
<input type="checkbox"/> <b>Audible Alarms</b>	
<b>RA FAN SPEED MODE</b>	
<b>Care Level</b>	<b>off</b>
<b>SERIAL COMM - DCOM</b>	

The color of the box next to **Auto Restart** indicates the status,  is enabled,  is disabled. In this screen the auto restart is disabled.

<input checked="" type="checkbox"/> <b>Auto Restart</b>
<input type="checkbox"/> <b>Audible Alarms</b>

To change the status highlight the line. Because the box is also now highlighted  indicates disabled and  indicates enabled. In this screen the feature is still disabled.

<input type="checkbox"/> <b>Auto Restart</b>
<input type="checkbox"/> <b>Audible Alarms</b>

Press the enter key to change the status. In this screen **Auto Restart** is enabled.

<input checked="" type="checkbox"/> <b>Auto Restart</b>
<input checked="" type="checkbox"/> <b>Audible Alarms</b>

Once the highlight is removed confirm the status of the Auto Restart feature. In this screen the **Auto Restart** feature is enabled.

## Audible Alarms

**Audible Alarms** is used to turn the audible alarm on/off.

<b>Line Frequency</b>	<b>60Hz</b>
<input type="checkbox"/> <b>Auto Restart</b>	
<input type="checkbox"/> <b>Audible Alarms</b>	
<b>RA FAN SPEED MODE</b>	
<b>Care Level</b>	<b>off</b>
<b>SERIAL COMM - DCOM</b>	

Use the same procedure described above to enable/disable the alarms.

In this screen the alarms are disabled.

## RA FAN SPEED MODE (ThermoFlex 2500 air-cooled chillers only)

**RA FAN SPEED MODE** controls the fan speed. **Auto** allows the fan to run under the conditions listed in Section 3. Selecting **On** allows the fan to run at high speed all the time.

**Note** **On** is required for the chiller to achieve its full cooling capacity specification. ▲

When the desired changes are made press the left arrow, or esc button, to return to the **SETTINGS** display.

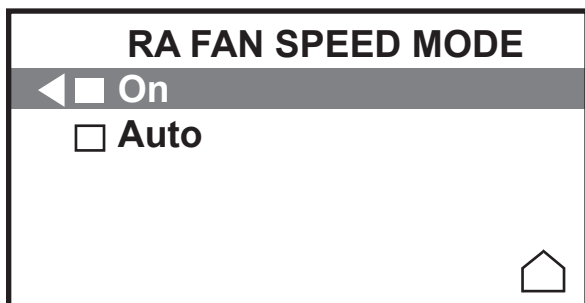

Fan Speed Range: **On** or **Auto**

Fan Speed Default: **Auto**

## Care Level

**Care Level** sets the preventive care cleaning frequency reminder for the chiller's air and fluid filters.

If a change to the level is needed, highlight **Care Level** and then press the enter button. The highlight will flash. Press the up or down arrow to bring up the desired level. Once the desired level is displayed press enter to accept the change and stop the flashing.

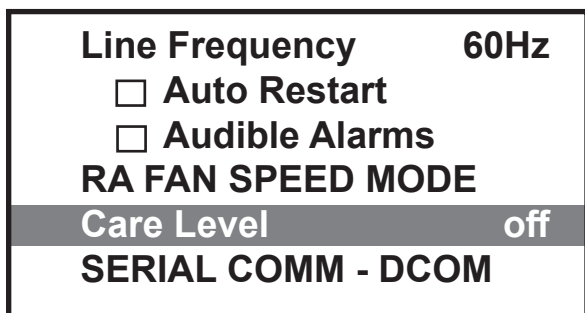

Care Level Range: **off**  
**1** (1000 hours)  
**2** (2000 hours)  
**3** (3000 hours)

Care Level Default: **1** (1000 hours)

See Section 6 for additional details.



## SERIAL COMM - DCOM (Optional)

**SERIAL COMM - DCOM** is used to configure/enable the chiller's optional serial communications feature. If a change to the setting is needed, press the arrows to highlight the desired line and then press the enter button. The highlight will flash. Press the up or down arrow to change the setting. Once the desired setting is displayed press enter to accept the change and stop the flashing.

**Note** None of the controller's other menu displays are available when serial comm is enabled. ▲

SERIAL COMM - DCOM	
Serial Type	off
Baud	xxx
Parity	xxx
Data Bits	8
Stop Bits	X
Address	xx

Serial Type: **RS232, RS485, off**

Baud Range: **9600, 4800, 2400, 1200, 600 or 300**

Parity: **even, odd or none**

Data Bits: Fixed at **8**

Stop Bits: **2 or 1**

Unit ID: **1 to 99** (RS 485 only)

If serial communications is enabled a general message will appear.

**Note** Keypad operation is still available with serial communications enabled. ▲

**MESSAGE!**  
**RS-232 Enabled**  
**Press ENTER**

Press enter to extinguish the message.

Refer to Appendix C for additional information.

## ANALOG COMM - ACOM (Optional)

**ANALOG COMM - ACOM** is used to configure/enable the chiller's optional analog communications feature. Press the arrows to highlight the desired option and then press the enter button. The  box will turn black  indicating that option is enabled. Press enter again to turn it off.



When operating a ThermoFlex7500-10000 with the remote sensor enabled ensure the chiller's response to lowering the setpoint does not result in operation below 10°C process temperature. Operation below 10°C requires the use of 50/50 EG/water or 50/50 PG/water. ▲

ANALOG COMM - ACOM	
<input checked="" type="checkbox"/> Remote Sensor	
<input type="checkbox"/> Remote Start	
<input type="checkbox"/> Remote Setpt	volts
<input type="checkbox"/> Temp Out	volts
RELAY 1	
RELAY 2	
USER RANGE SETTINGS	

When an option is enabled a general message will appear, for example:

**MESSAGE!**  
**Remote Sensor Enabled**  
**Press ENTER**

Press enter to extinguish the message.

Refer to Appendix D for additional information.

## RESISTIVITY (Optional)

**Note** This option is only available on standard-temp chillers. ▲

**RESISTIVITY** enables/configures the resistivity option. With **DE-I CONTROL** highlighted press enter to enable the feature. Next set the limits to the desired values.

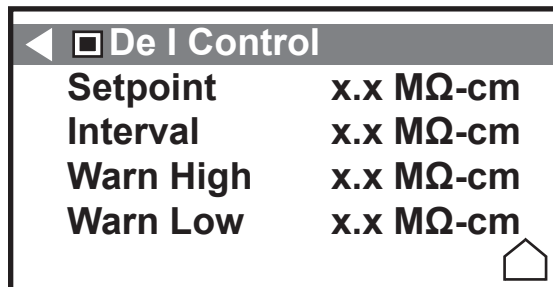
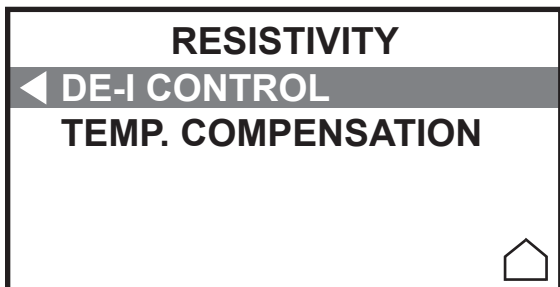

Resistivity	Range	Default
Setpoint:	0.2 to 3.0	1.0 MΩ-cm
Interval	0.1 to 0.5	0.1 MΩ-cm
Warning High:	0.0 to 3.5	3.0 MΩ-cm
Warning Low:	0.0 to 3.5	0.5 MΩ-cm

With **TEMP. COMPENSATION** highlighted press enter to turn compensation off or on.

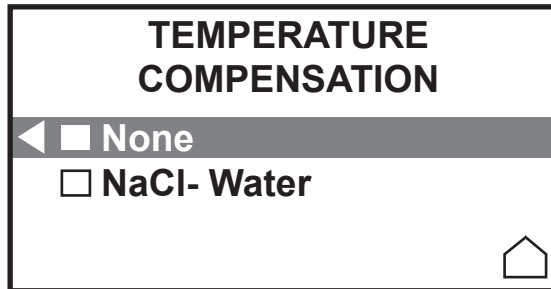
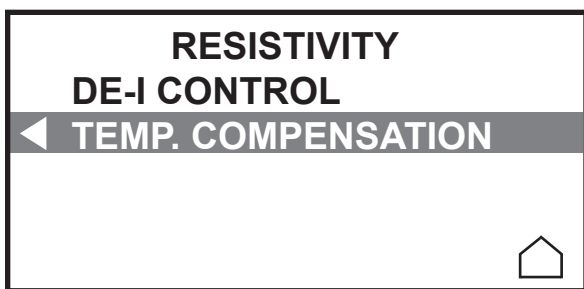

When the desired changes are made press the left arrow, or esc button, to return to the **SETTINGS** display.

## RESTORE DEFAULTS

**RESTORE DEFAULTS** restores the controller back to factory default values. A reset is automatically performed whenever new firmware is installed.

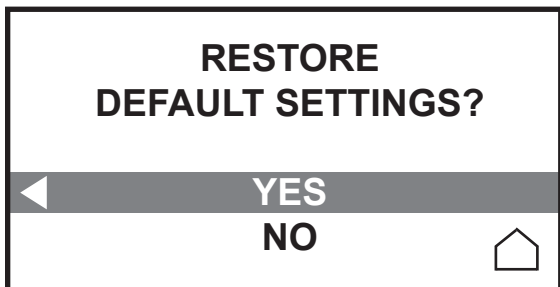

Press the left arrow, or esc button, to return to the **SETTINGS** display.

## mm/dd/yy hh:mm:ss

**mm/dd/yy hh:mm:ss** sets the date and time. Some error messages can display the date and time of occurrence, see Section 7.

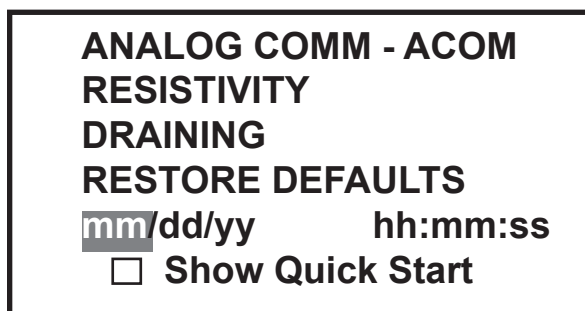

Press the arrows to highlight the desired setting. Press enter to start the highlight flashing. Press the arrows to change the setting. Press enter to accept the change and stop the flashing.

## Show Quick Start

**Show Quick Start** reruns the initial start up menu. The Quick Start menu will appear the next time the chiller is started.

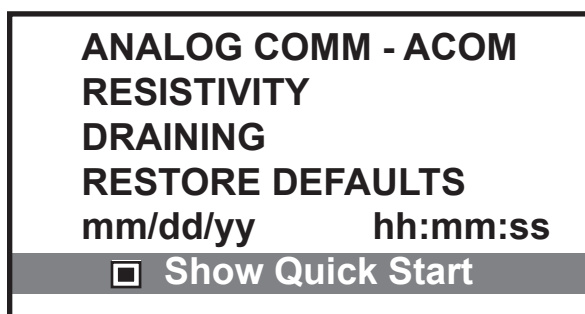

With **Show Quick Start** highlighted press enter. The Quick Start menu will appear the next time the chiller is started.

**Note** If **Show Quick Start** is enabled and power is lost, if auto restart was enabled the chiller will not automatically restart once power is restored. In this case only the controller is powered. ▲

## DRAINING (Optional)

**DRAINING** opens/closes the optional anti drainback valve. The chiller must be off to drain the valve. Press enter to start the draining. The display will change to **Close Valve**. When the draining is complete press enter again to close the valve.

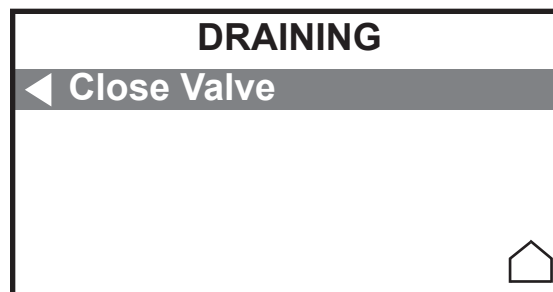
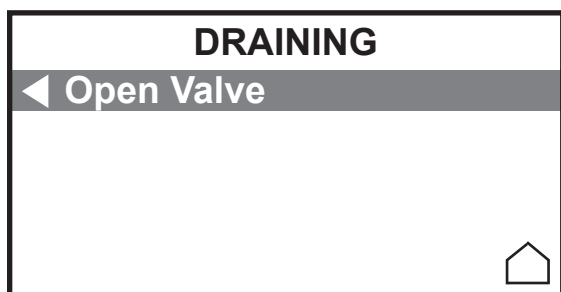

## Shut Down

Press the  button.

The controller displays:

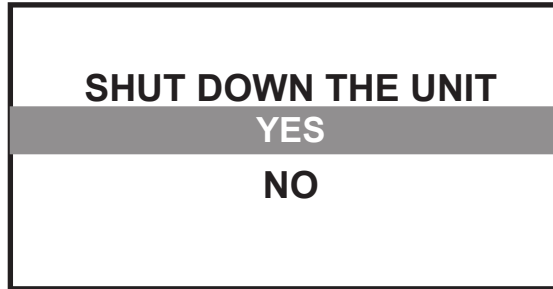

With **YES** highlighted, press enter.

To protect the compressor the chiller will enter a 5 to 20 second shut down cycle (colder process fluids take longer) before the refrigeration system and pump shut down.



The display then goes blank.



Using any other means to shut the chiller down can reduce the life of the compressor. ▲



Always turn the chiller off and disconnect it from its supply voltage before moving. ▲



The circuit protector located on the rear of the chiller is not intended to act as a disconnecting means. ▲

## Section 5 Options/Accessories

### Auto Refill

The auto refill provides makeup fluid to replace any fluid lost to evaporation, etc. It requires a pressurized fluid source connection to the ¼" Female Pipe Thread fitting on the rear of the chiller. (If Teflon<sup>®</sup> tape is used, ensure the tape does not cover the connection's starting-end thread.)

**Note** ThermoFlex7500 through 24000s with a P3, P5, T9 pump or ThermoFlex7500 and 10000s with a T5 pump have a ¼" Male brass plug installed in the connection, remove the plug before connecting the makeup fluid. ▲



**Figure 5-1** Auto Refill Fitting

The auto refill fluid must also meet water quality standards or the valve may fail to operate as designed, see Section 3.

The auto refill valve input pressure must be < 80 PSI to ensure the valve functions properly.

**Note** Adding fluid that has a temperature differential with the fluid already in the reservoir will temporarily affect temperature stability performance. ▲

The auto refill operates when all of the following conditions are met:

- Fluid is available
- The chiller is turned on
- The fluid reaches a low level condition.

The auto refill shuts off when:

- The fluid reaches the correct operating level.
- The delay timer exceeds user fill time entered in the Quick Start or **SETTINGS** menu.
- The chiller shuts down for any reason.

**Note** Setting the fill time to 0 disables auto refill. ▲

## Internal DI Cartridge

**Note** This option is not available on high-temp chillers. ▲

A partial flow DI filter cartridge is designed to maintain water resistivity between 1 and 3 MΩ-cm.

**Note** The DI option results in a 0.5 gpm reduction of available flow. ▲



**Do not use a Deionization (DI) filter cartridge with Inhibited EG or Inhibited PG. A DI filter will remove inhibitors from the solution rendering the fluid ineffective against corrosion protection. Also, inhibitors increase fluid conductivity. ▲**

The controller will display a **High Resistivity** or a **Low Resistivity** warning message when the process fluid resistivity exceeds the limit set in the controllers **RESISTIVITY SETTINGS** display, see Section 4.

Remove the two thumbscrews securing the DI access panel to the top of the chiller.

If there is a cartridge in place, first undo the hose fitting by pressing on the quick disconnect located on the top white connection.

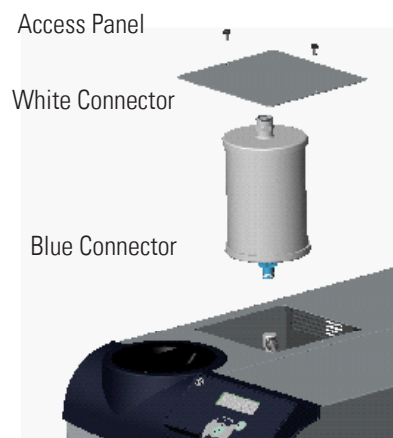

**Figure 5-2** Internal DI Cartridge



**The DI Cartridge will overpressurize if it is removed from the chiller before removing the hose fitting. ▲**

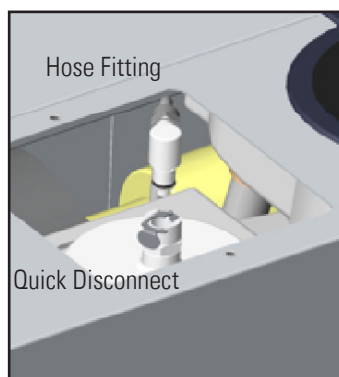

**Figure 5-3** DI Fittings

Next rotate the cartridge ¼ turn counter-clockwise and then pull the cartridge straight up to remove it.

Remove the new cartridge from the shipping bag. The cartridge has a blue and a white connector. Lower the cartridge into the chiller with the blue connector facing downward. Press down on the cartridge lightly to engage and then rotate it ¼ turn clockwise (do not over rotate) or until you feel the filter click into place.

Push the hose fitting into the quick disconnect located on the white end of the cartridge. Replace the access panel and thumbscrews.

**Note** The cartridge can be changed with the chiller running, however, since the cartridge runs in a parallel arrangement, disconnecting the cartridge adds 0.5 gpm to the main flow. The additional flow will cause an increase in system pressure which may cause a high fluid pressure fault. ▲



## P1 P2 T0 T1 Pump Pressure Relief Valve (Internal Configuration)

The pressure relief valve, located on the top left rear of the chiller, is used to set the desired system back pressure to your application. The valve is factory preset to  $80 \pm 5$  psi ( $5.5 \pm 0.4$  bar).

*If the chiller is not plumbed to an application,* set the pressure by installing a loop of hose equipped with a shut-off valve between the supply and return fittings. Start the chiller and allow it to prime, then close the valve.

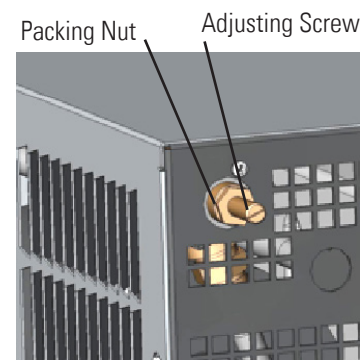

**Figure 5-4** Nut and Screw

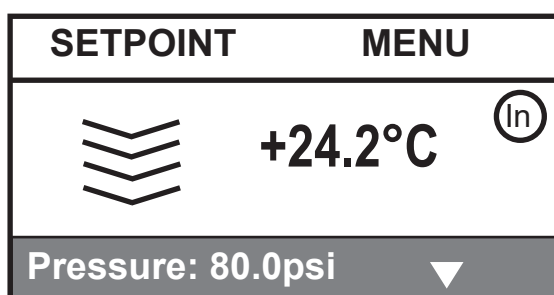

**Figure 5-5** Pressure Status Display

Use the Status Display to display P 1, it should display  $80 \pm 5$  psi.



Use a screwdriver to turn the adjusting screw (counterclockwise to reduce pressure) until the controller displays the desired setting.

**Note** Due to internal back pressure, the minimum pressure setting for a deadheaded pump is 32 psi (2.2 bar) for a P2 pump, and 8 psi (0.6 bar) for a P1 (these settings prohibit external flow from the chiller). ▲

*If the chiller is plumbed to an application,* ensure the chiller is off. Then back out the adjusting screw counterclockwise to reduce pressure. Turn the chiller on. Ensure that there is back pressure in the system. Turn the adjusting screw until the controller displays the desired setting.



**Do not exceed 100 psi (6.9 bar).** ▲

When complete, inspect the area around the  $\frac{5}{8}$ " packing nut for fluid. If fluid is present, slightly tighten the nut and reinspect.

**Note** Should the chiller start to vibrate the valve setting may be the cause. Changing the pressure setting  $\pm 5$  psi (0.3 bar) will eliminate the vibration. ▲

## P1 P2 T0 T1 Pump Pressure Relief Valve (External Configuration)

The pressure relief valve is used to set the desired system back pressure (P1) to your application. The valve is factory preset to  $80 \pm 5$  psi ( $5.5 \pm 0.4$  bar).

The valve's inlet/outlet connections are  $\frac{1}{2}$ " FNPT.

*If the chiller is not plumbed to an application, set the pressure by installing a loop of hose equipped with a shut-off valve between the supply and return fittings. Start the chiller and allow it to prime, then close the valve.*

Adjusting Screw

Packing Nut

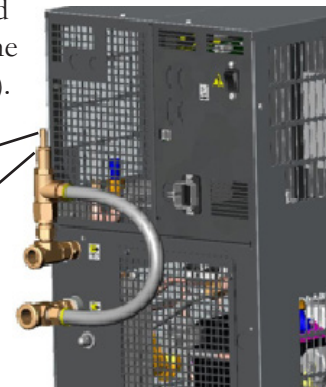

**Figure 5-6** Nut and Screw

Use the Status Display to display P1, it should display  $80 \pm 5$  psi.

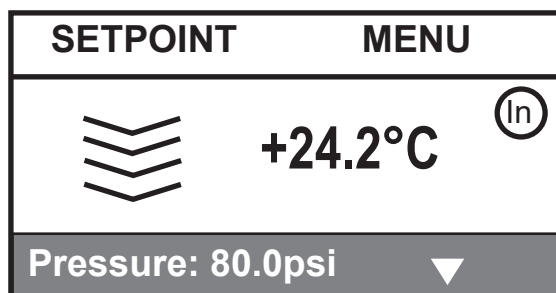

**Figure 5-7** Pressure Status Display

Use a screwdriver to turn the adjusting screw (counterclockwise to reduce pressure) until the controller displays the desired setting.

**Note** Due to internal back pressure, the minimum pressure setting for a deadheaded pump is 40 psi (2.8 bar) for a P2 pump, and 22 psi (1.5 bar) for a P1 (these settings prohibit external flow from the chiller). ▲

*If the chiller is plumbed to an application, ensure the chiller is off. Then back out the adjusting screw counterclockwise to reduce pressure. Turn the chiller on. Ensure that there is back pressure in the system. Turn the adjusting screw until the controller displays the desired setting.*



**Do not exceed 100 psi (6.9 bar). ▲**

When complete, inspect the area around the  $\frac{5}{8}$ " packing nut for fluid. If fluid is present, slightly tighten the nut and reinspect.

## Flow Control with Flow Readout

Flow control for P1, P2, T0 and T1 pumps on ThermoFlex900s - 5000s is achieved using a 3-way valve plumbed between the standard process outlet and the process inlet on the rear of the chiller. Use the auxiliary process outlet at the top left of the rear of the chiller as a connection point. The connections are 1/2" FNPT. See Figure 5-8.

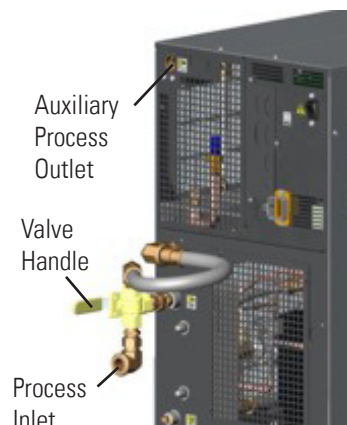
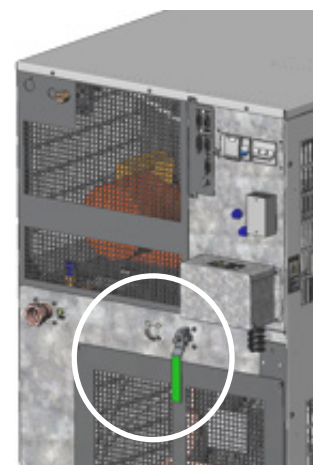

**Figure 5-8** Flow Control

ThermoFlex3500s and 5000s with P3 and P4 pumps use a 2-way valve located on the rear of the chiller. The connections are 3/4" FNPT. See Figure 5-9.

ThermoFlex7500s and 24000s with P2 - P5 and T5 (see next page) pumps use a valve located on the rear of the chiller. The connections are 1/2" for P2, 1" FNPT for P3 and P5. See Figure 5-9.

Use the controller's Status Display to view the flow rate. Turn the valve handle until the desired rate is displayed.



**Figure 5-9** Flow Control Handle (Typical)

**Note** The valve is sensitive to slight adjustments. ▲

## P1 P2 T0 T1 Pump Pressure Relief with Flow Readout

The pressure relief with flow readout works just like the pressure relief Valve discussed on the previous page. It allows you to control the pressure going to your application.

This valve is plumbed into the chiller's auxiliary port, allowing you to also monitor the flow rate to your application using the controller's Status Display.

The valve's outlet connection is 1/2" FNPT. See Figure 5-10.

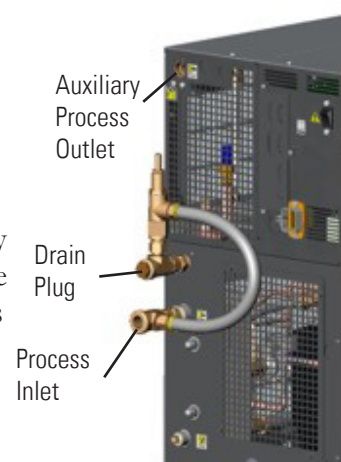

**Figure 5-10** Pressure Relief

## T5 Pump Flow Control

The flow control valve is used to adjust the flow rate. The valve's handle is designed to identify the valve's position, from full flow to full bypass. When the handle is in the horizontal position (in line with the discharge line) the application is receiving full flow. With the handle is vertical the valve is in full bypass.

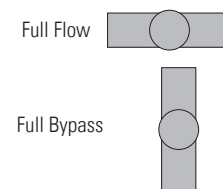

## Anti Drainback

Chillers installed below the end-user application may allow system fluid to drain back into the chiller and cause spillage. The anti-drainback valve is designed to prevent any such spillage.

The valve opens just before the pump is turned on and it closes just after the pump shuts off.

This option is required if your chiller is more than 24 feet below your application, or if there is a possibility of drain back due to the occasional opening of the process lines for either application swaps or chiller servicing.

## Semiconductor Equipment and Materials International (SEMI) Chillers

### Compliance

SEMI chillers are compliant with:

**SEMI S2-0703 Product Safety Assessment**

**SEMI S8-0705 Ergonomic Assessment**

**SEMI S14-0704 Fire Risk Assessment**

**SEMI F47-0706**

### Emergency Off (EMO)

A guarded red mushroom shaped push-button switch with twist-to-reset is provided on the chiller's front to turn it off in case of an emergency. The button head is engraved with "EMO" in large white filled letters.

**Note** The EMO is controlled by a safety circuit and is not influenced by the chiller's firmware/software. ▲

Activation of the EMO button will remove power from the main contactor coil stopping operation of the chiller. The controller will display **External EMO**.

Resetting the EMO button will not restart the chiller. After all hazards have been removed reset the chiller by pressing **enter** on the controller. In the local mode, the chiller will restart by pressing the START STOP button again. In the serial communications mode, send the appropriate start command. In the analog I/O mode, the chiller starts when the error is cleared.

### Chiller Circuit Breaker Interrupt Rating

The main power circuit breaker located on the rear of the chiller has an Interrupting Capacity (AIC) of 10,000 amps.

### Lockout/Tagout (LOTO)

Before performing Chiller maintenance, the energy sources associated with the chiller system must be lockedout and tagged out (LOTO). Hazard control features added to the system (e.g., safety interlocks, EMO) are not a substitute for turning off and locking out electrical or fluid energy.

For chillers rated 20 Amps or less, electrical LOTO is accomplished by removing the power cord on the rear of the chiller then closing and locking the power receptacle locking device. For other chillers, electrical LOTO is the responsibility of the user and can be provided by:

- Using the main disconnect (knife switch at system control cabinet).
- Disconnecting main power at the facility power source prior to the system controller cabinet.
- In addition, follow all OSHA and local facility LOTO directives.

### Drip Pan and Drain

The chiller is equipped with a secondary containment (drip pan) in case there is a leak. The drip pan drain is located on the rear of the chiller. Install the supplied nylon 1/4 turn quick disconnect (QD) fitting into the drain fitting. The QD is barbed for a 1/2" ID hose.

Since the drip pan will not hold more than 110% of the reservoir volume, connect the drain to guide the fluid to an appropriate spillage location.

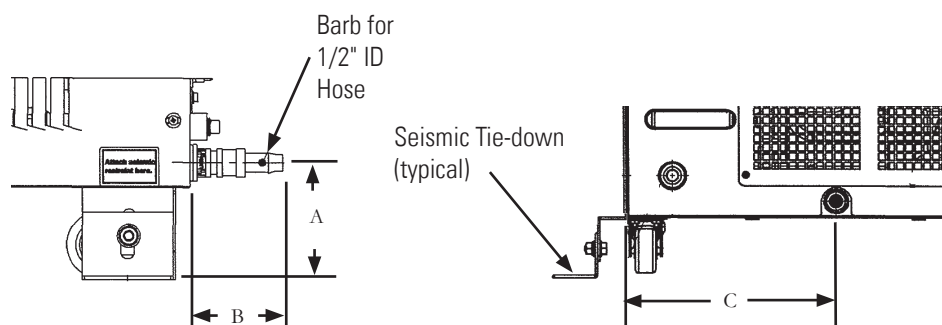

1/4 Turn Quick Disconnect Drip Pan Drain Fitting

**Figure 5-11** Drip Pan Drain

	900/1400		2500		3500/5000		7500/10000	
A	3 1/2"	8.8 cm	4"	10.1 cm	3 3/8"	11.3 cm	4 1/4"	10.8 cm
B	2 3/4"	7.0 cm	2 11/16"	6.8 cm	2 3/4"	7.1 cm	2 5/8"	6.6 cm
C	6 15/16"	17.7 cm	6 9/16"	16.7 cm	9 9/16"	24.3 cm	7 11/16"	19.5 cm

### Seismic Tie-Downs

Install the seismic tie-downs to the chiller as shown below. Then secure the chiller to the floor with user-supplied hardware.

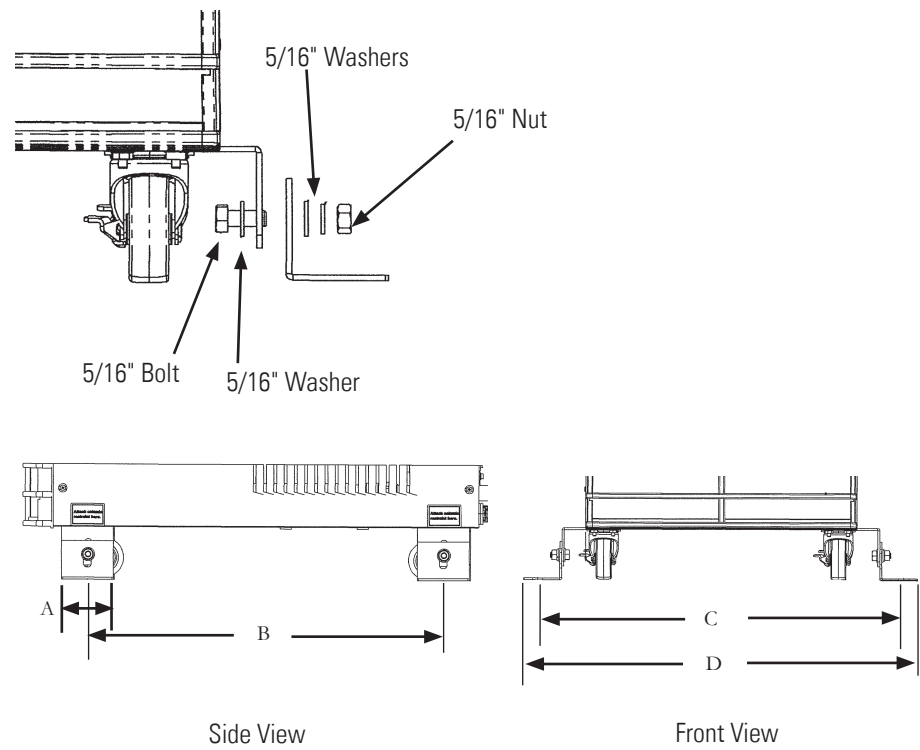

**Figure 5-12** Seismic Tie-Downs

	900/1400		2500		3500/5000		7500/10000	
A	2 11/16"	6.8 cm	2 11/16"	6.8 cm	2 11/16"	6.8 cm	2"	5.1 cm
B*	18 1/2"	47.0 cm	20 1/16"	51.0 cm	24 1/2"	62.2 cm	17"	43.1 cm
C*	19 11/16"	50.0 cm	22 3/4"	57.8 cm	24 3/4"	62.9 cm	27 7/16"	69.6
D	21 3/16"	53.8 cm	24 1/4"	61.5 cm	26 1/4"	66.7 cm	28 15/16"	73.4

\* Distance between Ø.53 Seismic mounting holes



## Center of Gravity

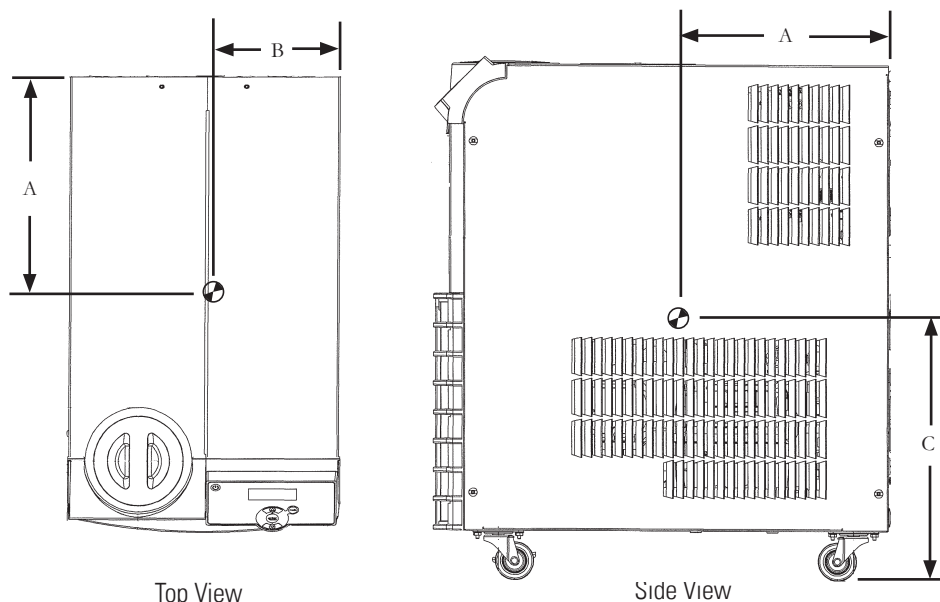

**Figure 5-13** Center of Gravity

Center of Gravity  $\pm \frac{1}{2}$ ", air-cooled chiller, no fluid in tank

	900/1400 P2 Pump		2500 P2 Pump		3500/5000 P2 Pump		7500/10000 P3 Pump	
A	10 <sup>3</sup> / <sub>4</sub> "	27.3 cm	12"	30.5 cm	13 <sup>3</sup> / <sub>8</sub> "	34.0 cm	14 <sup>7</sup> / <sub>8</sub> "	37.8 cm
B	6 <sup>3</sup> / <sub>4</sub> "	17.2 cm	8 <sup>3</sup> / <sub>8</sub> "	21.3 cm	9"	22.9 cm	13 <sup>1</sup> / <sub>8</sub> "	33.3 cm
C	13 <sup>1</sup> / <sub>2</sub> "	34.3 cm	13 <sup>1</sup> / <sub>2</sub> "	34.3 cm	17"	43.2 cm	26"	66.0 cm

### 3500/5000 P4 Pump Global Voltage

A	12 <sup>3</sup> / <sub>8</sub> "	31.4 cm
B	9 <sup>3</sup> / <sub>4</sub> "	24.8 cm
C	19 <sup>1</sup> / <sub>2</sub> "	49.5 cm

Center of Gravity  $\pm \frac{1}{2}$ ", water-cooled chiller, no fluid in tank

### 3500/5000 P2 Pump

A	13"	33.0 cm
B	9 <sup>1</sup> / <sub>2</sub> "	24.1 cm
C	16"	40.6 cm

Weight Distribution  $\pm 2$  lbs, air-cooled chillers

	900/1400 P2		2500 P2		3500/5000 P2		7500/10000 P3	
Left Front	27.1 lbs	12.3 kg	40.7 lbs	18.5 kg	62.0 lbs	28.1 kg	97.8 lbs	44.4 kg
Left Rear	29.8 lbs	13.5 kg	42.0 lbs	19.1 kg	63.7 lbs	28.9 kg	99.9 lbs	45.3 kg
Right Front	32.9 lbs	14.9 kg	45.7 lbs	20.7 kg	68.2 lbs	30.9 kg	89.2 lbs	40.5 kg
Right Rear	36.2 lbs	16.4 kg	47.1 lbs	21.4 kg	70.0 lbs	31.8 kg	91.1 lbs	41.3 kg

## Other Accessories

Installation kit - includes replacement air and fluid filters

Maintenance kit - includes a set of hoses, adaptor fittings and Teflon<sup>®</sup> tape

### Fluids

Fluid treatment kit designed to minimize the effects of corrosion, scale, fouling, and microbial contamination. It allows the system to continue providing reliable service with optimal efficiency for the life of the chiller.

The kit includes a biocide and corrosion inhibitor capable of treating up to ten gallons of application water and is designed to provide protection for a period of six months. This kit is compatible with the following fluids:

- Filtered/Single Distilled Water
- Uninhibited Ethylene Glycol/Water
- Uninhibited Propylene/Water
- Deionized (DI) Water\*
- Reverse Osmosis (RO) Water

\*Do not use the Thermo Fisher Water Treatment Kit with a DI filtered system; the filter will remove a portion of the reagent's active ingredients limiting its effectiveness.

Please contact Thermo Fisher Scientific's Sales, Service and Customer Support to assist you with questions that you may have regarding accessories for your ThermoFlex, see inside front cover for contact information.

## Section 6 Preventive Maintenance

### Preventive Maintenance Timer (Care Level)

Only Thermo Fisher should provide any required replacement parts.

The ThermoFlex chiller has an integrated preventive maintenance timer that can alert you when it is time to perform preventive maintenance. This unique feature can be set to remind you to change your air and fluid filters.

Based on the environment in which your chiller is located, you can choose from four levels of preventive maintenance off, L1, L2, and L3:

- off – Disables the alert
- L1 – 1,000 hours - default setting
  - Heavy manufacturing environment
  - Airborne particulate created during manufacturing process
- L2 – 2,000 hours
  - Typical production environment
- L3 – 3,000 hours
  - Clean environment – filtered air
  - Typically laboratory or research environment

Each time the chiller exceeds the chosen time, the controller will flash **Filter PM** and, if enabled, an audible alarm will sound.

Change/set the level using the controller's **DIAGNOSTICS** menu, see next page.

To clear this message press . This will temporarily clear the alarm until the chiller is restarted. To permanently clear the alarm the filter run time hours must be reset in the **DIAGNOSTICS** menu. Also, if you change your filters before the preventive timer trips, you can clear the timer by using the **DIAGNOSTICS** menu.

**Note** For air-cooled chillers, both the air and fluid filters in the ThermoFlex can be changed while the chiller is running. For water-cooled chillers, only the fluid filter can be changed while it is running. ▲

## DIAGNOSTIC - OPERATING HOURS

**OPERATING HOURS** displays the chiller (**Unit**), filter and optional DI cartridge operating hours. The display is also used to select the preventive maintenance schedule (**Care Level** and optional **De-I Period**).

1. Use the arrow buttons to highlight **OPERATING HOURS**.

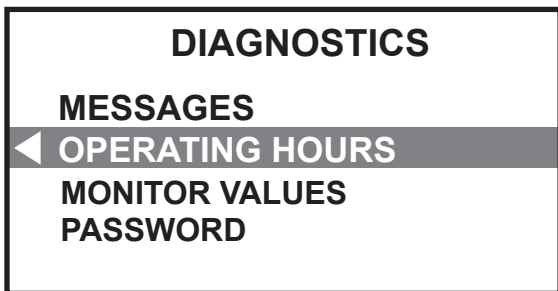

2. Press enter to display:

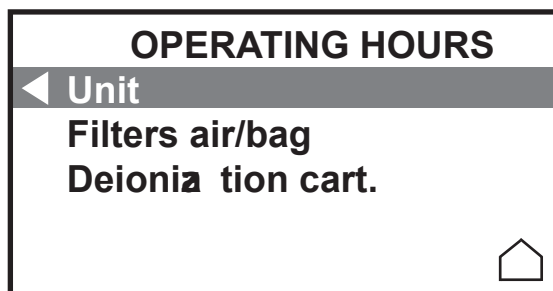

3. Highlight the desired item and press enter to bring up one of the displays shown on the right:

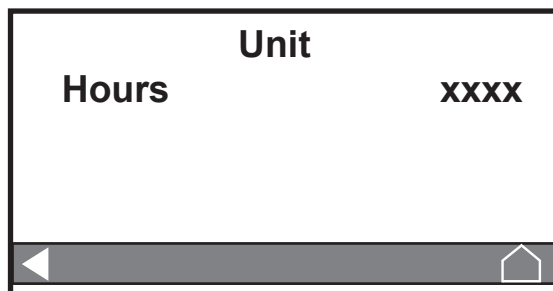

4. With **Reset** highlighted, press enter to reset the filter and cartridge operating hours to zero. You cannot reset the chiller's operating hours.



5. Use the arrow buttons to highlight **Care Level**. Press enter and the display will flash. Use the arrow buttons to display the desired care level and then press enter again to stop the flashing and accept the new value.

6. The optional **De-I Period** is the operating time needed to display the **DI** message. Use the arrow buttons to highlight **De-I Period**. Press enter and the display will flash. Use the arrow buttons to display the desired time, from 0 to 9999 hours. Press enter again to stop the flashing and accept the new value.

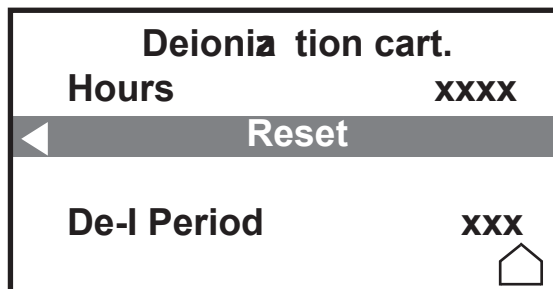

(Optional Display)

## Fluid Filter Bag

The reservoir has a fluid bag filter designed to prevent the introduction of particulates into the system.

**Note** The fluid bag filter can be removed with the chiller operating. ▲



**Before using any fluid or performing maintenance where contact with the fluid is likely refer to the manufacturer's SDS for handling precautions.** ▲



**For high-temperature chillers, ensure the fluid is at a safe temperature (below 40°C) before handling.** ▲

Fluid Bag Filter



When it is time to replace the bag, gently pull up on the plastic funnel housing to remove it and simply pull the bag out of the chiller. Replacement bags are available from Thermo Fisher Scientific.

**Figure 6-1** Fluid Filter Bag



**Before replacing the reservoir housing ensure the reservoir sight tube ball stopper is securely in place, see next page.** ▲

## Fluid Diffuser

On ThermoFlex900-5000s, when you remove the bag you will notice a wire mesh fluid diffuser inside the reservoir supply line, see Figure 6-2. The diffuser is used to help streamline the flow into the reservoir. After several bag replacements turn the chiller off and remove the diffuser to inspect it for debris/damage.



**The fluid velocity into the reservoir will rapidly increase with the diffuser removed and cause splashing. Turn the chiller off before removing the diffuser. This is especially critical when using ethylene or propylene glycol.** ▲

**Note** To prevent particulates from entering the reservoir, ensure the fluid bag filter is in place before removing the diffuser. ▲



**Do not operate the chiller unless the diffuser is installed.** ▲

## Fluid Maintenance

An effective recommended maintenance plan would include changing the fluid every six months to optimize chiller reliability, see Section 3 for additional information.

## Reservoir Cleaning

The user is responsible for maintaining reservoir fluid quality. Check the fluid on a regular interval. Start with frequent checks until a regular interval (based on your application) is established.

If cleaning is necessary, flush the reservoir with a fluid compatible with the process fluid and the chiller's wetted parts, see Section 8.



**Before using any fluid or performing maintenance where contact with the fluid is likely refer to the manufacturer's SDS for handling precautions. ▲**



**For high-temperature chillers, ensure the fluid is at a safe temperature (below 40°C) before handling. ▲**

### Reservoir Sight Tube

Clean the sight tube by gently pulling up on the plastic funnel housing to remove it (see illustration on previous page) and then gently pulling out the black sight ball stopper from the tube. Use a long soft-bristle 1/4" brush. Use caution not to scratch the glass.



**Before replacing the reservoir housing ensure the reservoir sight tube ball stopper is securely in place. ▲**

For easier replacement, wet the stopper first and then use a twisting motion to install it in the sight tube.

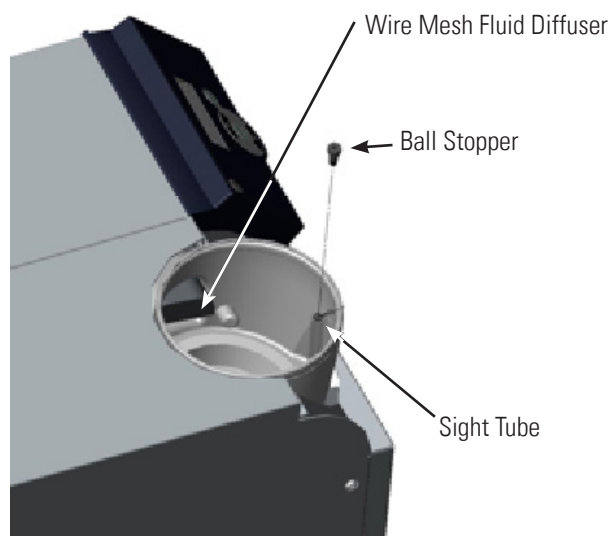

**Figure 6-2** Reservoir Cleaning and Diffuser



## Condenser Filter



Failure to clean/replace the condenser filter will cause a loss of cooling capacity and lead to premature failure of the cooling system. ▲

### ThermoFlex900s - 5000s

Clean the filter through the grill using a vacuum with a soft-bristle brush.

When it is time for a more thorough cleaning, remove the one-piece grill assembly by first pulling the bottom of the assembly away from the chiller and then pulling it away from the top.



The condenser framing and fins located behind the grill assembly are very sharp. Use caution when removing the assembly. ▲

**Note** ThermoFlex900s - 5000s water-cooled chillers have an embedded screw(s) located at the top (and bottom) of the grill securing it to the chiller. Loosen the screw(s) to remove the grill. ▲



Water-cooled chillers also have a fan with sharp blades, ensure the chiller is off before removing the assembly. ▲

Shake off as much of the excess water as possible before reinstalling. Press the grill back into place.

For water-cooled chillers, tighten the screw(s) at the top (and bottom) of the grill.

Replacement grill assemblies are available from Thermo Fisher.

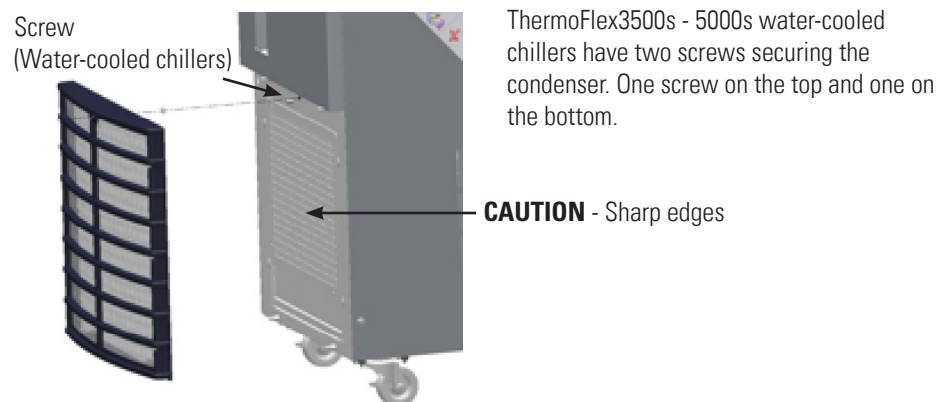

**Figure 6-3** ThermoFlex900s - 5000s Condenser Grill Removal

### **ThermoFlex7500s - 10000s**

For air-cooled chillers, remove the one-piece grill assembly by pulling the assembly away from the chiller.

Water-cooled chillers do not have a filter.

The filter goes over four studs and plastic "fast nuts" that hold it in place.

Replace it or vacuum the old filter with a soft-bristle brush, or wash it. Shake off as much of the excess water as possible before reinstalling.

Tuck the filter around the perimeter of the grill and over the four studs, use the plastic "fast nuts" to hold it in place.

Replacement grills are available from Thermo Fisher.

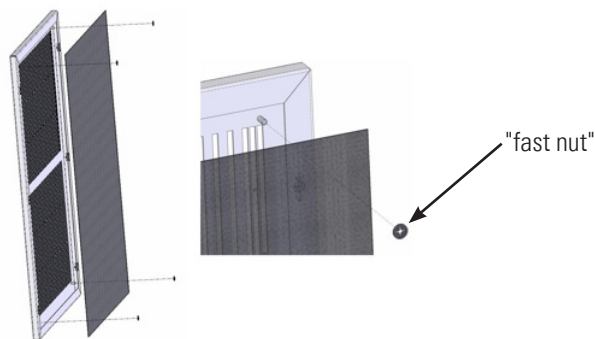

**Figure 6-4** Filter Removal/Replacement ThermoFlex7500s - 10000s Air-Cooled

### **ThermoFlex24000**

The air-cooled chillers do not have filters but the condenser fins can be cleaned by removing the eight screws securing the lower-front panel.

## **Chiller Surface**

Clean the chiller's surface with a soft cloth and warm water only.

## **Hoses**

Inspect the chiller's external hoses and clamps on a daily basis.

## Testing the Alarm Features

Using the Setup Loop, adjust each temperature alarm limit towards the setpoint and ensure the chiller reacts accordingly. Reset each alarm limit to the desired value. See Section 4.

We recommend slowly draining the chiller to ensure the low level warning and fault messages activated. See Section 8.

For chillers equipped with auto refill switch we recommend slowly draining and ensure the auto refill activates.

## DI Filter (Optional)

Establish a preventive maintenance schedule for the DI filter cartridge based on your specific application.

The controller will display a **High Resistivity** or a **Low Resistivity** warning message when the process fluid resistivity exceeds the limit set in the controllers **RESISTIVITY SETTINGS** display, see Section 4.

The chiller also has an integrated alarm. The alarm is based on chiller run hours that will alert you when it is time to change your filter. The alarm is enabled using the controller's **DIAGNOSTICS** menu.

If you already know how often your DI filter needs changing, you can input the number of hours into the menu. When the time is reached, the controller will flash **DEI PM** and the audible alarm, if enabled, will sound.

To clear this message and stop the audible alarm press  .

## Preventive Maintenance Messages

The controller also displays Preventive Maintenance Messages. These messages are based on the component run time and are established to avoid unplanned failures. The chiller will continue to run.



**Figure 6-5** Sample PM Message

<b>Filter PM</b>	<b>Fluid Filter Bag and Condenser Filter</b>
<b>DEI PM</b>	<b>Optional DI Filter</b>
<b>XXXXX Run Hours</b>	<b>Chiller operating hours (appears every 20,000 hours)</b>

You can press the enter button to clear any message. Note the message because once the Filter or DEI PM message is cleared it will not reappear.

## Section 7 Troubleshooting

### Messages

WARNING and FAULT Messages are a result of exceeding one of the controller's SETTINGS, see Section 4, exceeding a sensor factory preset safety value, or a safety switch is activated. An ERROR Message indicates an unusual condition. In the case of an ERROR or WARNING Message the chiller, if running, will continue to run. Press **enter** to see if the message clears, a limit may have been only temporarily exceeded. In the case of a FAULT Message the chiller will shut down and the controller will continue to flash the message. Press **enter** to clear the display and, if enabled, silence the alarm. Once the cause of the shut down is identified and corrected, restart the chiller. If the cause was not corrected the message will reappear.

<p><b>WARNING!</b> Low Level</p> <p>Pres ENTER</p>	<p><b>FAULT!</b> High Temp</p> <p>Pres ENTER</p>	<p><b>ERROR!</b> CAN Bus</p> <p>Pres ENTER</p>
--	--	--

Figure 7-1 Sample Messages

### Faults and Warnings

Message	Reaction	Cause	Actions
<b>Auto Refill</b>	The chiller will continue to run. Auto refill, if installed, will shut down. (Optional display - only chillers equipped with auto refill.)	The auto refill did not reach the minimum operating level within the time chosen for the customer adjustable <i>fill</i> setting.  The auto refill successfully filled within the time frame chosen for the customer adjustable <i>fill</i> setting, but the chiller tries to refill 5 times in 40 hours.	<ul style="list-style-type: none"> <li>• Check for leaks.</li> <li>• Check the supply pressure on the auto refill supply line. With low pressure the auto refill time span setting may be set too low and the reservoir does not have time to fill. Verify controller's <b>SETTINGS</b>, see Section 4.</li> <li>• Add fluid to the tank.</li> <li>• Contact our Sales, Service and Customer Support.</li> </ul>
<b>Bad Calibration Data</b>	Chiller continues to run.	Bad sensor calibration detected several seconds after performing a calibration.	<ul style="list-style-type: none"> <li>• Redo calibration, see Section 8.</li> <li>• Contact our Sales, Service and Customer Support.</li> </ul>

## Faults and Warnings

Message	Reaction	Cause	Actions
<b>Drip Pan</b>	Chiller will shut down. (SEMI chillers only)	Fluid in the drip pan.	<ul style="list-style-type: none"> <li>• Check for leaks.</li> <li>• Remove the fluid from the drip pan and reset the fault.</li> <li>• Contact our Sales, Service and Customer Support.</li> <li>• When able, reset external EMO..</li> </ul>
<b>External EMO</b>	Chiller will shut down. (SEMI chillers only)	External EMO depressed.	<ul style="list-style-type: none"> <li>• Allow chiller to cool down.</li> <li>• For air-cooled chillers, clean air filter, see Section 6.</li> <li>• Contact our Sales, Service and Customer Support.</li> </ul>
<b>Fan Motor Overload</b>	Chiller will shut down. (3- $\Phi$ chillers only)	Fan motor overload activated.	<ul style="list-style-type: none"> <li>• Check application valves and ensure that they have not changed or been closed. <b>Note</b> If routine shut-off of the process flow is required then add an external pressure regulator accessory - contact Thermo Fisher. ▲</li> <li>• May occur as a result of changing the internal DI cartridge. Disconnecting the cartridge adds an additional 0.5 GPM to the main flow, see Section 5.</li> <li>• Check for debris in the application or clogged external filters.</li> <li>• Double check fluid lines. Excessive bends, long tubing and diameter reductions can affect the pump's discharge pressure. <b>Note</b> If diameter reductions must be made, make them at the inlet and outlet of your application, not at the chiller. ▲</li> <li>• Contact our Sales, Service and Customer Support.</li> </ul>
<b>High Fixed Pressure</b>	Chiller will shut down. This error code has priority over <b>High Pressure</b> error code.	Process pressure (P1) exceeded <i>factory preset</i> value for greater than 30 seconds. Preset Values: P1, P2, T1, T5 and T9 - 105 psi P3 60 Hz - 48 psi P3 50 Hz - 32 psi P4 60 Hz - 85 psi P4 50 Hz - 60 psi P5 60 Hz - 87 psi P5 50 Hz - 56 psi	



## Faults and Warnings

Message	Reaction	Cause	Actions
<b>High Fixed Temp</b>	<p>Chiller will shut down.</p> <p>This error code has priority over <b>High Temp</b> error code.</p> <p><b>Note</b> Chiller will not restart until process fluid temperature is below +43°C (+93°C for high-temp chillers). ▲</p>	<p>Reservoir fluid temperature exceeded the <i>factory preset</i> value of +43°C (+93°C for high-temp chillers).</p>	<ul style="list-style-type: none"> <li>• Ensure all environmental requirements are met, see Section 3.</li> <li>• Ensure chiller has adequate ventilation, see Section 3.</li> <li>• Clean air filter. Dirt and debris on filter can prevent the chiller from functioning at full capacity, see Section 6.</li> <li>• Ensure that the heat load being applied to the chiller is not too high. Contact Thermo Fisher for assistance on calculating heat loads.</li> <li>• Bring cooler air in from another area or exhaust the hot air into another location using an auxiliary fan.</li> <li>• Verify/adjust controller PID values, see <b>TUNING</b> in this Section.</li> <li>• Contact our Sales, Service and Customer Support.</li> </ul>
<b>High Flow</b>	<p>With a warning message the chiller will continue to run.</p> <p>With a fault message the chiller will shut down.</p> <p>(Optional display - only chillers equipped with a flow transducer.)</p>	<p>The process fluid flow rate has exceeded the adjustable setting's high value.</p>	<ul style="list-style-type: none"> <li>• If the chiller is still running press enter to see if the code clears, the limit may have been only temporarily exceeded.</li> <li>• Verify <b>SETTINGS</b>, see Section 4, and adjust setting if necessary.</li> <li>• Check all application and plumbing shut off valves for correct position.</li> <li>• Adjust flow, if chiller is equipped with an optional flow control valve, see Section 5.</li> <li>• If flow transducer was recently calibrated double check calibration, see Section 8.</li> <li>• Contact our Sales, Service and Customer Support.</li> </ul>

## Faults and Warnings

Message	Reaction	Cause	Actions
<b>High Pressure</b>	With a warning message the chiller will continue to run. With a fault message the chiller will shut down.	The pump's discharge pressure exceeded the adjustable high value.	<ul style="list-style-type: none"> <li>• If the chiller is still running press enter to see if the message clears, the limit may have been only temporarily exceeded.</li> <li>• Verify controller's <b>SETTINGS</b>, see Section 4.</li> <li>• Check application valves and ensure that they have not changed or been closed. <b>Note</b> If routine shut-off of the process flow is required then add an external pressure relief valve, see Section 5. ▲</li> <li>• Check for debris in the application or external filters.</li> <li>• May occur as a result of changing the internal DI cartridge. Disconnecting the cartridge adds an additional 0.5 gpm to the main flow, see Section 5.</li> <li>• Double check fluid lines. Excessive bends, long tubing and diameter reductions can affect the pump's discharge pressure. <b>Note</b> If diameter reductions must be made, make them at the inlet and outlet of your application, not at the chiller. ▲</li> <li>• Contact our Sales, Service and Customer Support.</li> </ul>
<b>High RA Temperature</b>	Chiller will shut down.	Refrigeration suction gas temperature exceeded 50°C.	<ul style="list-style-type: none"> <li>• Make sure supply voltage matches the chiller's nameplate rating <math>\pm 10\%</math>.</li> <li>• Contact our Sales, Service and Customer Support.</li> </ul>
<b>High Resistivity</b>	Chiller will continue to run. (Optional display)	The process fluid resistivity exceeded the upper adjustable value.	<ul style="list-style-type: none"> <li>• Press enter to see if the message clears, the limit may have been only temporarily exceeded.</li> <li>• Verify controller's <b>SETTINGS</b>, see Section 4.</li> <li>• Replace DI filter and/or process fluid.</li> <li>• Contact our Sales, Service and Customer Support.</li> </ul>

## Faults and Warnings

Message	Reaction	Cause	Actions
<b>High Temp</b>	With a warning message the chiller will continue to run. With a fault message the chiller will shut down. <b>Note</b> If the chiller does shut down it can be restarted provided the temperature is still within the factory-set high fixed temperature limit. However, the error will reoccur if the temperature goes below the adjustable setting and then again exceeds it. ▲	The process fluid temperature exceeded the adjustable high value.	<ul style="list-style-type: none"> <li>• If the chiller is still running press enter to see if the message clears, the limit may have been only temporarily exceeded.</li> <li>• Verify controller's <b>SETTINGS</b>, see Section 4.</li> <li>• Ensure all environmental requirements are met, see Section 3.</li> <li>• Ensure chiller has adequate ventilation, see Section 3.</li> <li>• Clean air filter. Dirt and debris on filter can prevent the chiller from functioning at full capacity, see Section 6.</li> <li>• Ensure that the heat load being applied to the chiller is not too high. Contact Thermo Fisher for assistance on calculating heat loads.</li> <li>• Bring cooler air in from another area or exhaust the hot air into another location using an auxiliary fan.</li> <li>• Verify/adjust controller PID values, see <b>TUNING</b> in this Section.</li> <li>• Contact our Sales, Service and Customer Support.</li> </ul>
<b>HPC</b>	Chiller will shut down.	High refrigeration pressure cutout activated.	<p><b>Air-cooled chillers</b></p> <ul style="list-style-type: none"> <li>• Ensure that the ambient temperature is not exceeding the recommended range, see Section 3.</li> <li>• Ensure chiller has adequate ventilation, see Section 3.</li> <li>• Clean air filter, see Section 6.</li> <li>• Bring cooler air in from another area or exhaust the hot air into another location using an auxiliary fan.</li> <li>• Contact our Sales, Service and Customer Support.</li> </ul> <p><b>Water-cooled chillers</b></p> <ul style="list-style-type: none"> <li>• Ensure facility water is on and connected.</li> <li>• Check facility water flow rate and pressure.</li> <li>• Contact our Sales, Service and Customer Support.</li> </ul>
<b>HTC</b>	Chiller will shut down.	Low fluid level or High heater temperature.	<ul style="list-style-type: none"> <li>• Check reservoir fluid level.</li> <li>• Allow heater to cool and then remove the small black plastic cap(s) on the rear of the chiller, press the reset node(s) until you hear a “click.” See <b>Checklist</b> in this Section.</li> <li>• Contact our Sales, Service and Customer Support.</li> </ul>

## Faults and Warnings

Message	Reaction	Cause	Actions
<b>Invalid Level</b>	Chiller will shut down.	Invalid level fault. Chiller sensed both a high level and low level reservoir fluid level.	<ul style="list-style-type: none"> <li>Contact our Sales, Service and Customer Support.</li> </ul>
<b>Invalid rem setpt</b>	Chiller will continue to run using the last valid setpoint received. (Optional display - only chillers equipped with Analog I/O).	Analog remote setpoint is enabled and the chiller receives a voltage or current level that is outside the chiller's set point range.	<ul style="list-style-type: none"> <li>The error can be cleared only after a valid set point is received, or the remote analog setpoint is turned off.</li> </ul>
<b>LLC</b>	Chiller will shut down.	Low Level Cutout activated.	<ul style="list-style-type: none"> <li>Check for leaks.</li> <li>Contact our Sales, Service and Customer Support.</li> </ul>
<b>Local EMO</b>	Chiller will shut down. (Optional display)	Chiller's EMO button depressed.	<ul style="list-style-type: none"> <li>When able, reset chiller's EMO.</li> </ul>
<b>Low Fixed Flow</b>	Chiller will shut down. (Optional display - only chillers equipped with a flow transducer) (This error code has priority over <b>Low Flow</b> .)	<p>Low flow fault. For chillers with a P1,P2,T1 or T9 pump the flow dropped below 0.8 GPM for more than 15 seconds.</p> <p>For chillers with a P3, P4 or P5 pump the flow dropped below 3.8 GPM for more than 15 seconds.</p>	<ul style="list-style-type: none"> <li>Adjust flow, if chiller is equipped with an optional flow control valve, see Section 5.</li> <li>Check all valves in your application and plumbing lines to ensure that they have not changed or closed.</li> <li>If flow transducer has recently been calibrated, double check calibration to ensure it was done properly, see Section 4.</li> <li>Contact our Sales, Service and Customer Support.</li> </ul>
<b>Low Fixed Pressure</b>	Chiller will shut down. (This error code has priority over <b>Low Pressure</b> .)	Process pressure (P1) below <i>factory preset</i> low limit of 2 psi for greater than 15 seconds.	<ul style="list-style-type: none"> <li>Ensure that the chiller reservoir is not empty.</li> <li>Chiller requires &gt;2 PSIG application pressure drop. If a bypass valve has been installed, some restriction may need to be added to the bypass line.</li> <li>Contact our Sales, Service and Customer Support.</li> </ul>

## Faults and Warnings

Message	Reaction	Cause	Actions
<b>Low Fixed Temp</b>	Chiller will shut down.  Note Chiller will not restart until process fluid temperature exceeds +2°C. ▲ (This error code has priority over <b>Low Temp</b> .)	Reservoir fluid temperature below the <i>factory preset</i> low value of +2°C, -8°C for ThermoFlex24000	<ul style="list-style-type: none"> <li>• Check ambient temperature. Chiller may not be able to reach setpoint at low ambient temperatures. If your load is constant, then turn your chiller on. Chiller will control setpoint when sufficient heat is added.</li> <li>• Verify/adjust controller PID values, see <b>TUNING</b> in this Section.</li> <li>• Add insulation to external plumbing lines to reduce the heat-loss to the environment.</li> <li>• Ensure that the ambient temperature is not exceeding the recommended range, see Section 3.</li> <li>• For water-cooled chillers check facility water temperature.</li> <li>• Contact our Sales, Service and Customer Support.</li> </ul>
<b>Low Flow</b>	With a warning message the chiller will continue to run. With a fault message the chiller will shut down.  (Optional display - only chillers equipped with a flow transducer.)	The process fluid flow rate has gone below the adjustable setting's low value.	<ul style="list-style-type: none"> <li>• If the chiller is still running press enter to see if the code clears, the limit may have been only temporarily exceeded.</li> <li>• Verify controller's <b>SETTINGS</b>, see Section 4.</li> <li>• Adjust flow, if chiller is equipped with an optional flow control valve, see Section 5.</li> <li>• Check all valves in your application and plumbing lines to ensure that they have not changed or closed.</li> <li>• If flow transducer has recently been calibrated, double check calibration to ensure it was done properly, see Section 4.</li> <li>• Contact our Sales, Service and Customer Support.</li> </ul>
<b>Low Level</b>	With a warning message the chiller will continue to run. With a fault message the chiller will shut down.	Reservoir fluid level too low for normal operation.	<ul style="list-style-type: none"> <li>• Excessive evaporation. Ensure the chiller is operating with the funnel and cap in place.</li> <li>• Check for leaks.</li> <li>• Check auto refill operation, see Section 5.</li> <li>• Check the supply pressure on the auto refill supply line. With low pressure the auto refill time span setting may be set too low and the reservoir does not have time to fill. Verify controller's <b>SETTINGS</b>, see Section 4.</li> <li>• Contact our Sales, Service and Customer Support.</li> </ul>

## Faults and Warnings

Message	Reaction	Cause	Actions
<b>Low Pressure</b>	With a warning message the chiller will continue to run. With a fault message the chiller will shut down.	Pump's discharge pressure is below adjustable low setting.	<ul style="list-style-type: none"> <li>• If the chiller is still running press enter to see if the message clears, the limit may have been only temporarily exceeded.</li> <li>• Verify controller's <b>SETTINGS</b>, see Section 4.</li> <li>• Ensure that chiller reservoir is not empty.</li> <li>• Chiller requires &gt;3 PSIG application pressure drop. If a bypass valve has been installed, some restriction may need to be added to the bypass line.</li> <li>• Contact our Sales, Service and Customer Support.</li> </ul>
<b>Low Resistivity</b>	Chiller will continue to run. (Optional display)	The process fluid resistivity exceeded the lower adjustable value.	<ul style="list-style-type: none"> <li>• Press enter to see if the message clears, the limit may have been only temporarily exceeded.</li> <li>• Verify controller's <b>SETTINGS</b>, see Section 4.</li> <li>• Replace DI filter and/or process fluid.</li> <li>• Contact our Sales, Service and Customer Support.</li> </ul>
<b>Low Temp</b>	With a warning message the chiller will continue to run. With a fault message the chiller will shut down. <b>Note</b> If the chiller does shut down it can be restarted provided the temperature is still above the factory-set low fixed temperature limit. However, the error will reoccur if the temperature goes above the adjustable setting and then again drops below it. ▲	Process fluid temperature is below adjustable low value.	<ul style="list-style-type: none"> <li>• If the chiller is still running press enter to see if the code clears, the limit may have been only temporarily exceeded.</li> <li>• Verify controller's <b>SETTINGS</b>, see Section 4.</li> <li>• Ensure that the ambient temperature is not exceeding the recommended low-range, see Section 3. If your application load is constant and/or the lower temperature can be temporarily tolerated, then continue operation. (The ThermoFlex will control setpoint when sufficient heat is added.)</li> <li>• Add insulation to external plumbing lines to reduce the heat-loss to the environment.</li> <li>• For water-cooled chillers check facility water temperature.</li> <li>• Contact our Sales, Service and Customer Support.</li> </ul>
<b>LPC</b>	Chiller will shut down.	Low refrigeration pressure cutout switch activated.	<ul style="list-style-type: none"> <li>• Check for refrigerant leak.</li> <li>• Contact our Sales, Service and Customer Support.</li> </ul>



## Faults and Warnings

Message	Reaction	Cause	Actions
<b>Open RTD</b>	Chiller will shut down.	Internal sensor open.	<ul style="list-style-type: none"> <li>Contact our Sales, Service and Customer Support.</li> </ul>
<b>Open Remote RTD</b>	Chiller will shut down.	Remote temperature sensor not connected or open.	<ul style="list-style-type: none"> <li>Check the connections on the rear of the chiller.</li> <li>Contact our Sales, Service and Customer Support.</li> </ul>
<b>Over Flow</b>	Chiller will shut down.	There is an overflow condition in the reservoir.	<ul style="list-style-type: none"> <li>Ensure the reservoir was not filled above the MAX LEVEL line.</li> <li>Check for clogged reservoir filter.</li> <li>Contact our Sales, Service and Customer Support.</li> </ul>
<b>Shorted Remote RTD</b>	Chiller will shut down.	Remote temperature sensor shorted.	<ul style="list-style-type: none"> <li>Check the connections on the rear of the chiller.</li> <li>Contact our Sales, Service and Customer Support.</li> </ul>
<b>Shorted RTD</b>	Chiller will shut down.	Internal sensor shorted.	<ul style="list-style-type: none"> <li>Contact our Sales, Service and Customer Support.</li> </ul>
<b>Motor Overload</b>	Chiller will shut down. (Chiller equipped with 3- $\Phi$ pump motor overload)	Pump motor exposed to excessive current due to high pressure, flow or ambient temperature.	<ul style="list-style-type: none"> <li>Allow pump to cool down.</li> <li>Contact our Sales, Service and Customer Support.</li> </ul>
<b>Phase Monitor</b>	Chiller will shut down. (3- $\Phi$ chillers only)	Phase rotation is wrong.	<ul style="list-style-type: none"> <li>Disconnect chiller from power source and reverse any two line conductors on the line side of the main circuit breaker.</li> <li>Contact our Sales, Service and Customer Support.</li> </ul>
<b>UNIT FAULT</b>	Chiller will shut down.	Critical error.	<ul style="list-style-type: none"> <li>Contact our Sales, Service and Customer Support.</li> </ul>

**Error**

Message	Reaction	Cause	Actions
<b>Async Rec Err Int</b>	Chiller will continue to run.	Communication error between display and main control board.	<ul style="list-style-type: none"> <li>• Check the serial communication connection.</li> <li>• Cycle circuit protector on the rear of the chiller off and on.</li> <li>• Contact our Sales, Service and Customer Support.</li> </ul>
<b>CAN Bus</b>	Chiller will continue to run.	Internal communications error.	<ul style="list-style-type: none"> <li>• Contact our Sales, Service and Customer Support.</li> </ul>
<b>I2C Bus</b>	Chiller will continue to run.	Internal communications error.	<ul style="list-style-type: none"> <li>• Contact our Sales, Service and Customer Support.</li> </ul>
<b>NO 5V CAL</b>	Chiller will continue to run.	No 5V calibration stored in controller memory.	<ul style="list-style-type: none"> <li>• Contact our Sales, Service and Customer Support.</li> </ul>
<b>NO PRES CAL</b>	Chiller will continue to run.	No pressure calibration stored in controller memory.	<ul style="list-style-type: none"> <li>• Perform a pressure calibration, see Section 8.</li> <li>• Contact our Sales, Service and Customer Support.</li> </ul>
<b>NO RTD CAL</b>	Chiller will continue to run.	No temperature calibration stored in controller memory.	<ul style="list-style-type: none"> <li>• Perform a temperature calibration, see Section 8.</li> <li>• Contact our Sales, Service and Customer Support.</li> </ul>
<b>NVS 3 4 RESET</b>	Chiller will not start.	Bad checksum when chiller is started. (Normal when new software is installed.)	<ul style="list-style-type: none"> <li>• Press enter to try and clear the message.</li> <li>• Try a restart.</li> <li>• Contact our Sales, Service and Customer Support.</li> </ul>
<b>SENSE 5V</b>	Chiller will continue to run.	Voltage out of tolerance.	<ul style="list-style-type: none"> <li>• Contact our Sales, Service and Customer Support.</li> </ul>

**MESSAGES** displays the ten most recent warnings and faults. The date and time each error occurred is shown. The alarm value is also displayed. Use the arrow buttons to scroll through the list of messages. Press enter to show the deletion options, **Single** or **All**. Choose **Single** to delete the selected error or **All** to delete all errors in the category. Press enter to show the delete confirmation screen. Finally, press enter again to make the deletion.

1. From the Main Menu display use the arrow buttons to highlight **DIAGNOSTICS**.

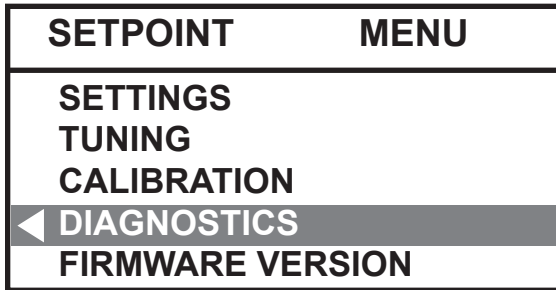

2. Press enter and use the arrow buttons to highlight **MESSAGES**.

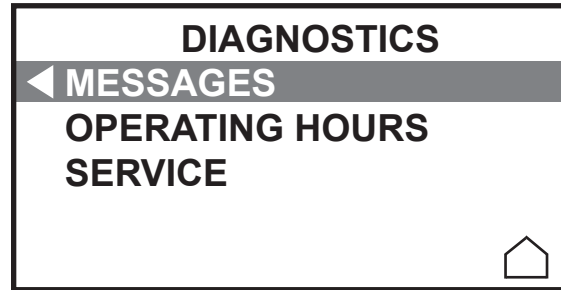

3. Press enter to display:

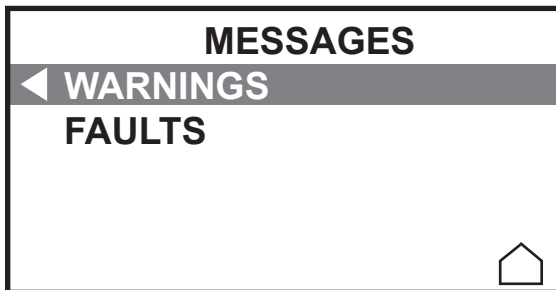

4. Highlight the desired type message and press enter again to display:

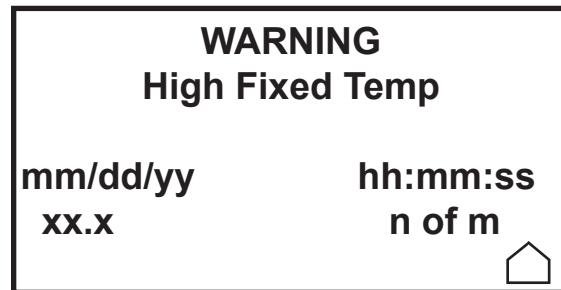

5. If desired, press enter again to display:

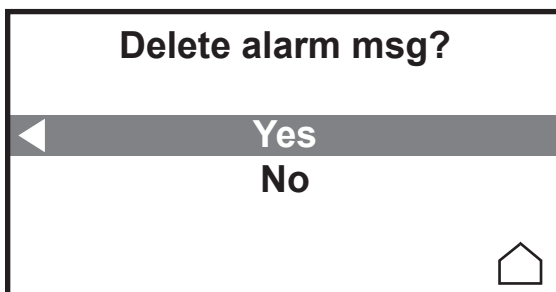

6. If **Yes** is selected press enter again to display:

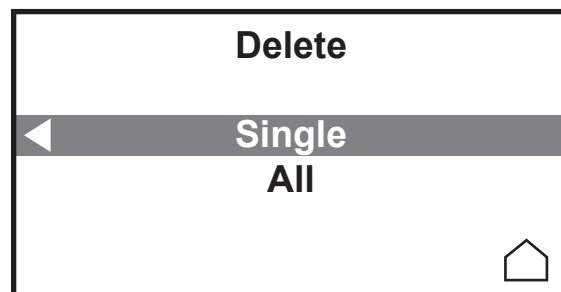

For either message type, if there aren't any messages the display will indicate:

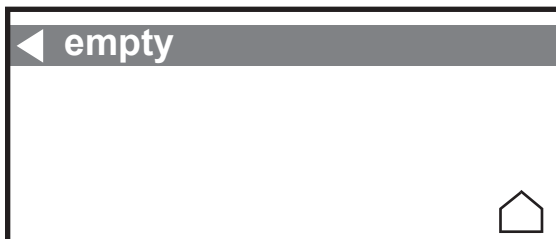

## Checklist

### Chiller will not start

Check the electrical connections.

For first time use, please refer to the quick start instructions included with your chiller or the copy in this manual. The manual's copy follows the Table of Contents.

Check the controller for messages, see Messages in this Section.

Ensure the circuit protector is in the on ( **I** ) position.

Make sure supply voltage is connected and matches the chiller's nameplate rating  $\pm 10\%$

### Chiller shuts down

Check the electrical connections.

Ensure  button wasn't accidentally pressed.

Ensure the circuit protector is in the on ( **I** ) position.

Check the controller for messages, see Messages in this Section.

The chiller is designed to shut down if not properly primed, refer to Section 3 for priming instructions.

Make sure supply voltage is connected and matches the chiller's nameplate rating  $\pm 10\%$ .

Restart the chiller.

### Clearing Messages

Note the code in case it clears before you are done troubleshooting.

If desired, silence the audible alarm by pressing enter.

*If the chiller shut down* the controller will continue to display the message. Press **enter** to clear the display and silence any alarm. Refer to Messages in this section. Once the cause of the shut down is identified and corrected, start the chiller. If the cause was not corrected the message will reappear.

*If the chiller is still running* press **enter** to see if the message clears, a limit may have been only temporarily exceeded. If the message does not clear refer to Messages in this Section.

### Inadequate pump pressure

Ensure any user installed in-line valves are in the desired position.

Ensure the chiller's process fluid outlet is connected to the application's fluid inlet and not the application's fluid outlet, see Section 3.

Ensure all connections are secure and that the proper sealant/lubricant for the fitting material is used.

Keep the distance between the chiller and the instrument being cooled as short as possible.

Ensure tubing is straight and without bends. If diameter reductions are required, make them at the inlet and outlet of your application, not at the chiller.

### **Chiller will not circulate process fluid**

Check the reservoir level. Fill, if necessary.

Ensure the reservoir bag filter is not clogged.

Check the application for restrictions in the cooling lines.

Chiller requires >3 PSIG application pressure drop. If a bypass valve has been installed, a restriction may need to be added to the bypass line.

The pump motor overloaded. The pump's internal overtemperature overcurrent device will shut off the pump causing the flow to stop. This can be caused by low fluid, debris in system, operating chiller in a high ambient temperature condition or excessively confined space. Allow time for the motor to cool down.

Make sure supply voltage matches the chiller's nameplate rating  $\pm 10\%$ .

### **Inadequate temperature control**

Adding fluid that has a temperature differential with the fluid already in the reservoir will temporarily affect temperature stability performance.

Verify the setpoint.

For high-temperature chillers check the heater's high temperature safety. Remove the two small black plastic covers on the rear of the chiller and press on each of the black stems. If the safety activated you should hear a "click." If it activates again contact us.



If the chiller is over-cooling, recycle the power.

Make sure the condenser/air filter is free of dust and debris.

Check the fluid concentration, see Section 3.

Ensure your chiller's installation complies with the site requirements listed in Section 3.

Make sure supply voltage matches the chiller's nameplate rating  $\pm 10\%$ . For ThermoFlex900 - 5000 Global Voltage chillers ensure it is properly configured, see Appendix B.

If the temperature continues to rise, make sure your application's heat load does not exceed the rated specifications.

Check for high thermal gradients (e.g., the application load is being turned on and off or rapidly changing).

If operating at high altitude note that heat removal capacity decreases 1.2% per 1,000 feet above sea level. Also, reduce the maximum temperature for the air entering the ThermoFlex by 1°C per 1,000 feet above sea level.

Verify/adjust controller PID values, see next page. Ensure the chiller was shut down properly, see Section 4. If not the compressor may be damaged.

### **Chiller vibration**

The optional pressure relief valve setting may be the cause. If it is, change the pressure setting  $\pm 5$  psi to eliminate the vibration.

Please contact Thermo Fisher Scientific Sales Service and Customer Support if you need any additional information, see inside cover for contact instructions.



# TUNING

## Verifying/ Adjusting the Controller PID Values

The controller controls temperature using a Proportional-Integral-Derivative (PID) algorithm. Should your chiller experience temperature control issues, verifying/adjusting the controller's PID values may correct the condition.

**Note** Thermo Fisher recommends that only a qualified technician adjust the PID values. Incorrect values will hamper chiller performance. ▲

1. From the Main Menu display use the arrow buttons to highlight **TUNING**.

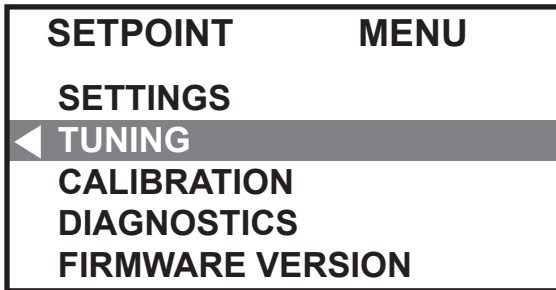

2. Press enter and highlight **COOL PID** or **HEAT PID**.

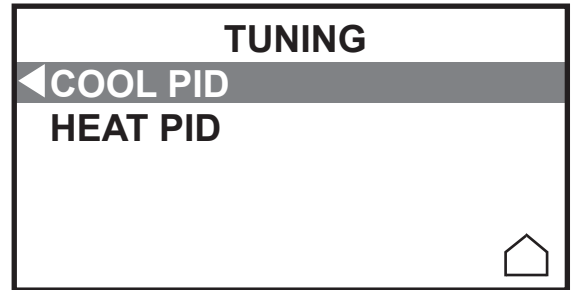

**Note** **HEAT PID** only appears on chillers equipped with a heater. ▲

3. Highlight and change the desired values as required.

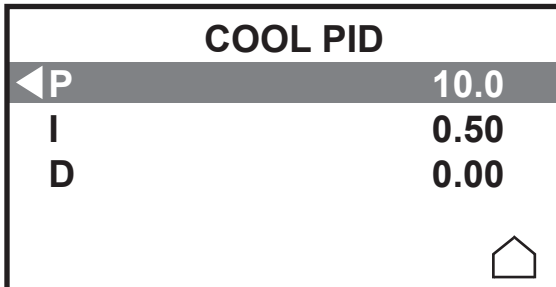

### COOL

**P** proportional value, % of span (100°C)

**Range:** 0.0 to 99.9

**Factory Preset:** ThermoFlex900-5000 10.0  
 ThermoFlex7500-10000 20.0  
 ThermoFlex24000 10.0

**I** integral value, repeats/minute

**Range:** 0.00 to 9.99

**Factory Preset:** ThermoFlex900-24000 0.50

**D** derivative value, minutes

**Range:** 0.0 to 9.9

**Factory Preset:** ThermoFlex900-24000 0.0

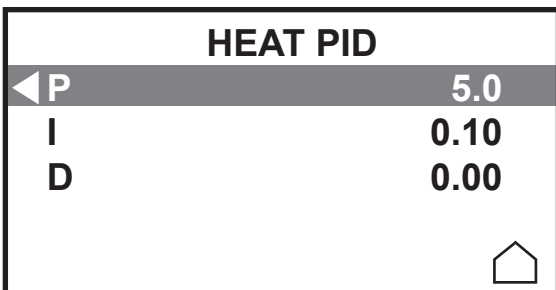

### HEAT

**P** proportional value, % of span (100°C)

**Range:** 0.0 to 99.9

**Factory Preset:** ThermoFlex1400-24000 5.0

**I** integral value, repeats/minute

**Range:** 0.00 to 9.99

**Factory Preset:** ThermoFlex1400-24000 0.10

**D** derivative value, minutes

**Range:** 0.0 to 9.9

**Factory Preset:** ThermoFlex1400-24000 0.0



## Section 8 Additional Information

### Draining



Before using any fluid or performing maintenance where contact with the fluid is likely refer to the manufacturer's SDS for handling precautions. ▲

Ensure the fluid is below the safe-handling temperature (below 40°C) before draining the chiller. ▲

The drain port is located on the rear. There are two different types, depending on the pump, a 1/4" stainless steel FPT with 1/4" brass pipe plug or a 1/4" MPT Riton fitting.

Position a suitable pan beneath the drain port. The drain pan must be shallow (under 3 1/2" in height) and have a volume of approximately 3 gallons (6 gallons for ThermoFlex7500 - 24000). Remove the 1/4" Male NPT pipe plug or, using a 9/16" wrench, open the Riton fitting by turning either counter clock wise. For ThermoFlex7500-24000, open the drain valve. This will drain the return line, reservoir, plate exchanger, and the suction side of the pump.

To drain the discharge side of the pump disconnect the Female NPT outlet connection on the rear of the chiller.

**Note** Internally the chiller does not contain a large quantity of fluid on the discharge side however take care to contain what fluid does drain, a wet-vac can be employed to minimize the potential for spillage. ▲

If the chiller is equipped with the flow control or pressure relief with flow control option, open the valve or remove the drain plug in order to drain the discharge line, see Section 5.

If the chiller is equipped with the anti drainback option, use the controller's **SETTINGS** menu to open the valve, see Section 4. Opening the valve allows the fluid to drain out of the chiller.

Reinstall 1/4" Male NPT pipe plug using a sealant suitable for the wetted materials or close the Riton filling prior to refilling the chiller.



**Do not overtighten the fitting.** ▲

For ThermoFlex7500-24000, close the drain valve.

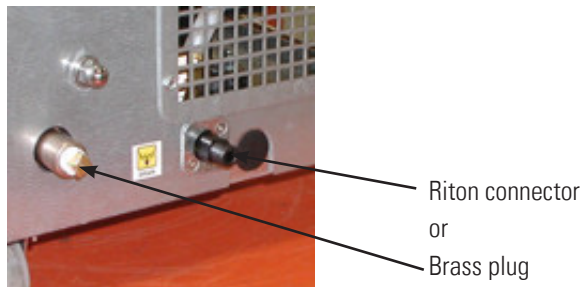

**Figure 8-1** Drains

**Water-Cooled**

Draining ThermoFlex1400 - 2500 water-cooled chillers is accomplished by removing the right side panel. Use a Phillips head screwdriver to remove the five screws indicated in the illustration below. Slide the panel back approximately one inch, then lift slightly from the rear to disengage the panel's two tabs from their slots.

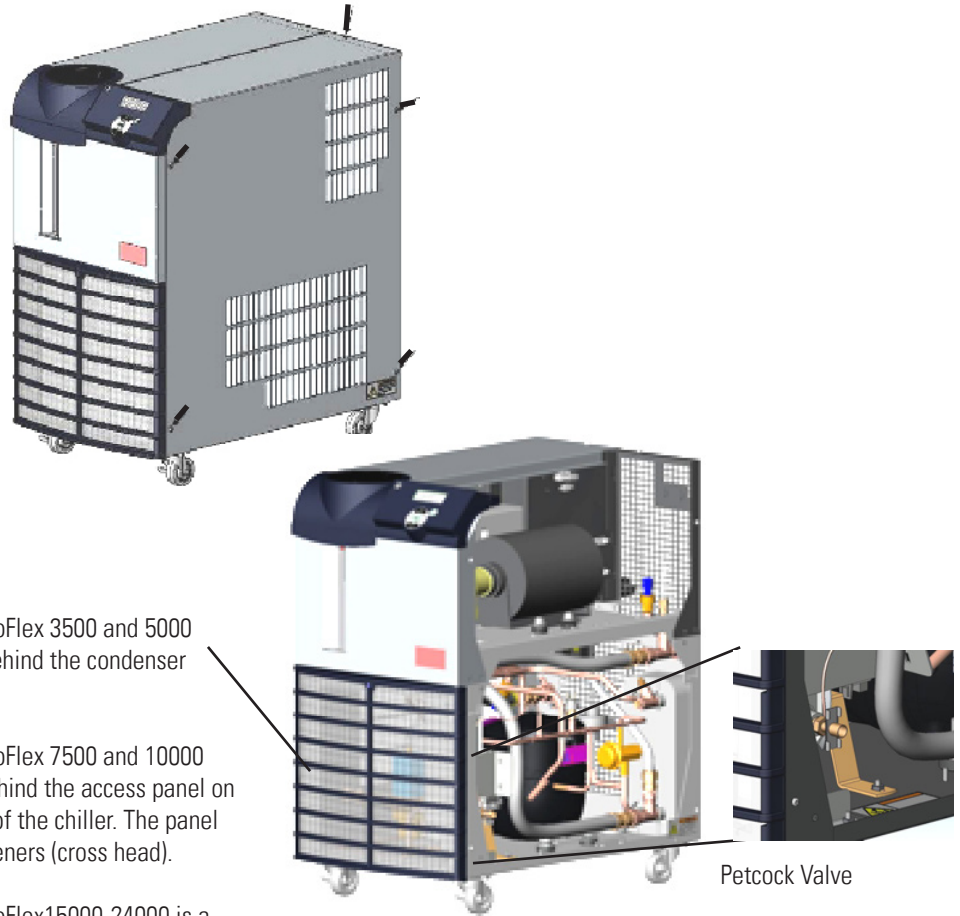

The drain for ThermoFlex 3500 and 5000 chillers is located behind the condenser filter.

The drain for ThermoFlex 7500 and 10000 chillers is located behind the access panel on the lower left front of the chiller. The panel has two ¼ turn fasteners (cross head).

The drain for ThermoFlex15000-24000 is a ¼" plug located on the rear of the chiller.

Petcock Valve

**Figure 8-2** Water-Cooled

Install a 7/16" ID tube on the drain petcock valve located on the lower end of the exchanger. Open the valve to allow fluid to drain into an external device. When draining is complete close the valve and replace the panel.

A wet-vac is needed on the facility water inlet connection to thoroughly drain any remaining fluid from the lines.

# CALIBRATION

The ThermoFlex has been designed to minimize the need for calibration. However, if calibration is desired or recommended by our Sales, Service and Customer Support, please use the following procedure.

**CALIBRATION** calibrates the chiller's temperature (**t1**), pressure (**p2**) and optional fluid flow (**flow1**) sensors. Each calibration requires a running chiller and a calibrated reference device. Typically, a 2-point calibration is used. Select which point to calibrate, **Low** or **High**. Press enter and enter the value as read by the reference device. Press enter. Select **Cal.** to the right of the value just entered by pressing the down button. Press enter and note that the **Current** value now equals the value just entered.

1. Highlight **CALIBRATION**.

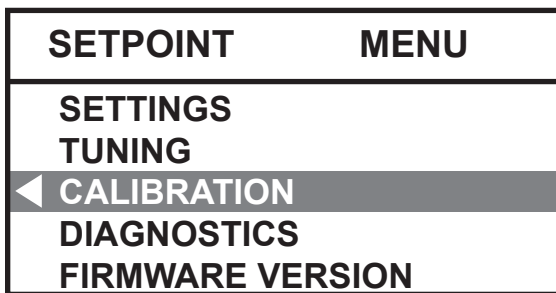

2. Press enter and highlight **CALIBRATE**.

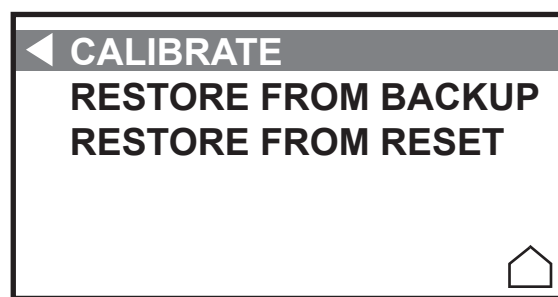

3. Press enter to display:

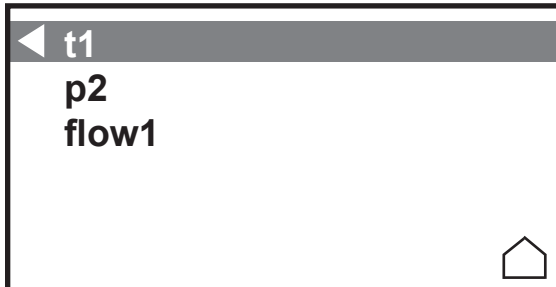

4. Highlight the desired sensor then press enter to display:

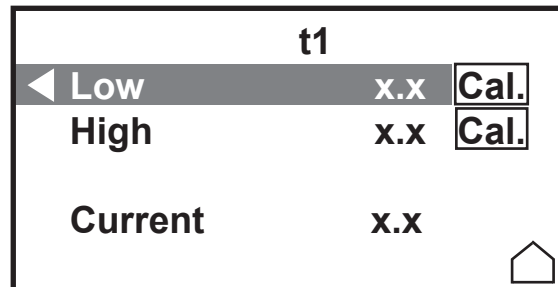

For **t1**, run the chiller to a suitable high-end calibration point. Place a calibrated reference thermometer in the reservoir. Ensure the fluid temperature is stabilized before performing the calibration. If it is more convenient, perform the low-end calibration before doing the high-end. Do not pick calibration points that are outside the safe operating limits of the fluid in your application. For example, with water, 40°C and 5°C are typical high and low calibration points (90°C and 5°C for high-temperature chillers).

For **p2**, connect a calibrated reference pressure gauge to the outlet line. Use an external flow control valve to adjust the pressure to suitable calibration points. Ensure the pressure is stabilized before calibrating.

For **flow1**, connect a calibrated reference flow meter to the outlet line. Use an external flow control valve to adjust the flow to suitable calibration points. Ensure the flow is stabilized before calibrating.

To restore a selected sensor to the factory values you have two options, **BACKUP** and **RESET**. **BACKUP** restores both the controller board and sensor calibration, **RESET** only restores the board calibration.

**Wetted Materials**

**P1, P2, MD1 and MD2 Pumps**

300 Series Stainless Steel  
Bronze  
Carbon Graphite  
Ceramic  
Fluorocarbon (Viton®)  
Polysulfone

**T0 and T1 Pumps**

Stainless Steel AISI 304  
Bronze ASTM B62  
Bronze ASTM B16  
Buna N  
Buna/Ceramic  
Buna/Carbon

**T5 Pumps**

Stainless Steel AISI 304  
Bronze w/monel  
Carbon  
Buna N  
Ceramic

**T9 Pumps**

Silicon Brass  
Stainless Steel AISI 304  
Stainless Steel 316, 18-8  
Bismuth Bronze  
Viton

**Tank**

Polyethylene (standard temp chiller)  
Polyvinylidene Difluoride (high temp)  
Brass  
EPDM  
Pyrex®  
Riton® (optional drain fitting)  
Viton® (optional drain fitting o-ring)

**P3, P4 and P5 Pumps**

316 Series Stainless Steel  
Carbon  
Silicon Carbide  
Fluorocarbon (Viton®)

**Plumbing**

300 Series Stainless Steel  
Bronze  
Fluorocarbon (Viton®)  
Nickel  
Polypropylene  
EPDM  
Brass  
Copper  
Teflon®  
PPS (flow transducer)  
Nitrile (Buna-n®)

**Filter bag**

Polypropylene  
Mono-filament nylon

**Cap and Funnel**

Acetal Copolymer



## Decommissioning/ Disposal



Decommissioning prepares equipment for safe and secure transportation.

Laboratory Grade Ethylene glycol (EG) is poisonous and flammable. Before disposing refer to the manufacturer's most current SDS for handling precautions. ▲



Decommissioning must be performed only by qualified dealer using certified equipment. All prevailing regulations must be followed. ▲

Consider decommissioning the chiller when:

- It fails to maintain desired specifications
- It no longer meets safety standards
- It is beyond repair for its age and worth

Refrigerant and compressor oil must be recovered from equipment before disposal.

**Note** Keep in mind any impact your application may have had on the chiller. ▲

Direct questions about chiller decommissioning or disposal to our Sales, Service and Customer Support.



Handle and dispose in accordance with the manufacturers specification and/or the SDS for the material used. ▲

## Shipment/Storage



Follow the manufacturer's SDS instructions if decontamination is required. ▲



Transporting and/or storing the chiller requires draining, see Draining in this Section. Store the chiller in the temperature range of -25°C to 60°C (with packaging), and <80% relative humidity. ▲



If the chiller is stored for more than 90 days it must be flushed with clean fluid before operating. ▲



# Appendix A Country Specific

## 230 VAC, 50 Hz, 1Ø Requirements

Refer to the nameplate label located on the rear of the chiller for specific electrical requirements.

### 1. Chillers shipped to the following locations require a **16 Amp service**:

Afghanistan, Albania, Algeria, Andorra, Angola, Argentina, Armenia, Austria, Azerbaijan, Belarus, Belgium, Benin, Bolivia, Bosnia and Herzegovina, Brazil, Bulgaria, Burkina Faso, Burundi, Cambodia, Cameroon, Cape Verde, Central African Republic, Chad, Chile, Comoros, Congo, Croatia, Czech Republic, Denmark, Djibouti, DR Congo, Ecuador, Egypt, Eritrea, Estonia, Ethiopia, Finland, France, French Guiana, Gabon, Georgia, Germany, Greece, Guinea, Hungary, Iceland, Indonesia, Iran, Iraq, Israel, Italy, Ivory Coast, Jordan, Kazakhstan, Kyrgyzstan, Latvia, Lebanon, Liberia, Libya, Liechtenstein, Lithuania, Luxembourg, Madagascar, Mali, Mauritania, Moldova, Monaco, Mongolia, Morocco, Mozambique, Namibia, Nepal, Netherlands, Niger, North Korea, Norway, Paraguay, Peru, Poland, Portugal, Romania, Russia, Rwanda, Saint Vincent and the Grenadines, San Marino, Sao Tome and Principe, Saudi Arabia, Senegal, Serbia, Slovakia, Slovenia, Somalia, South Africa, South Korea, Spain, Sweden, Switzerland, Syria, Tajikistan, Thailand, Togo, Tunisia, Turkey, Turkmenistan, Ukraine, Uruguay, Uzbekistan, Vanuatu, Vatican City, Vietnam.

---

### 2. Chillers shipped to the following locations require a **15 Amp service**:

Australia, China, Fiji Islands, Nauru, New Zealand, Papua New Guinea, Solomon Island, Tonga, Tuvalu.

---

### 3. Chillers shipped to the following locations require a **13 Amp service**:

Abu Dhabi, Bahrain, Bangladesh, Botswana, Brunei, Cyprus, Dominica, Gambia, Ghana, Gibraltar, Grenada, Hong Kong, India, Ireland, Kenya, Kiribati, Kuwait, Lesotho, Malawi, Malaysia, Maldives, Malta, Mauritius, Myanmar, Nigeria, Oman, Pakistan, Qatar, Saint Lucia, Seychelles, Sierra Leone, Singapore, Sri Lanka, Sudan, Swaziland, Tanzania, Uganda, United Arab Emirates, United Kingdom, Yemen, Zambia, Zimbabwe.

---

# Appendix B Voltage Configuration Instructions

ThermoFlex 900 and 1400 chillers equipped with the 115V 60Hz, 100v 50/60Hz Variable Voltage option and ThermoFlex 900 to 5000 chillers equipped with 200-230V 50/60Hz Global Voltage option have a voltage configuration panel located on the rear of the chiller behind an access panel, see Figure B-1.

- Use a 1/4" socket to remove the four screws securing the access panel to the chiller.
- The configuration panel has two 3-position toggle switches, one for voltage and one for frequency. All chillers are shipped with the toggle switch in the center **SHIP** position. Place each switch to the settings that match the voltage/frequency supplied to the chiller.

**Note** For ThermoFlex900-2500 global voltage chillers, the compressor and fan will not operate when the switch is in the **SHIP** position. ▲

- Reinstall the access panel.

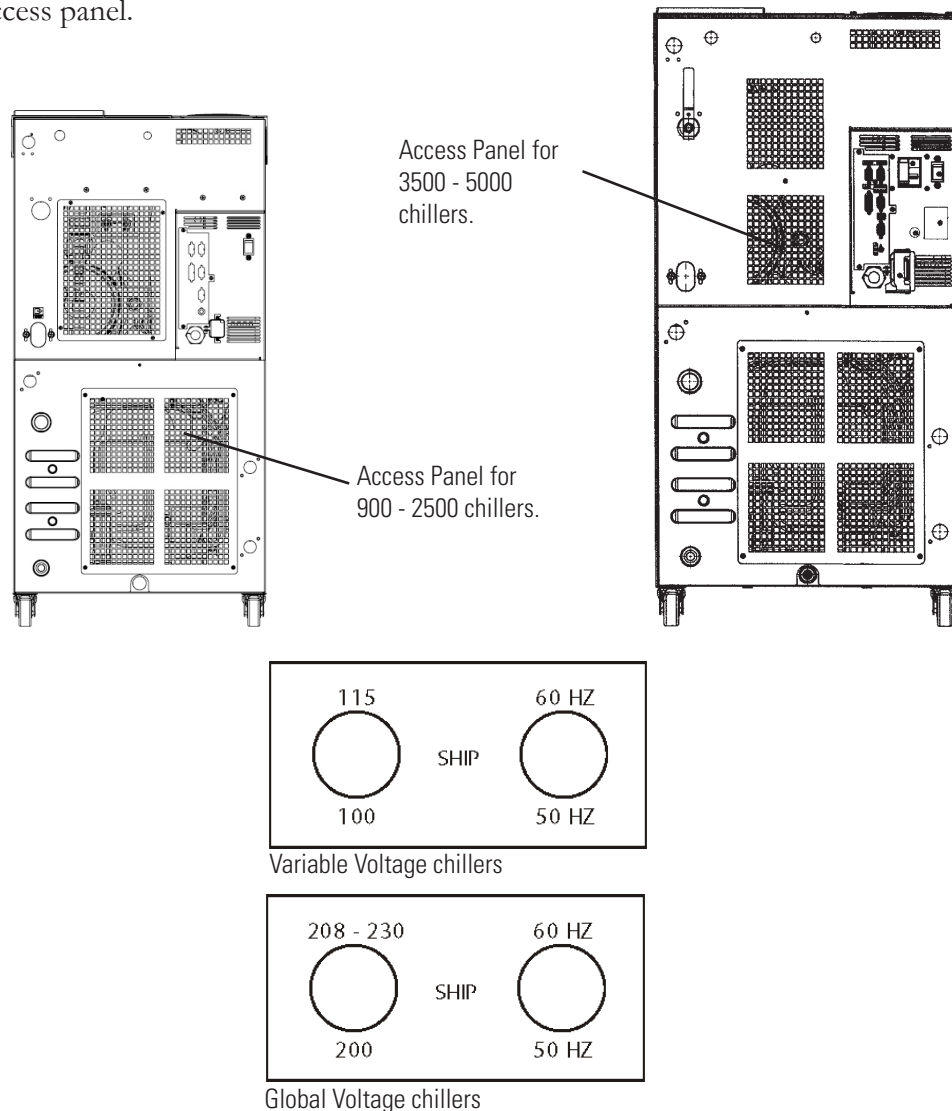

**Figure B-1** Variable/Global Voltage Chillers

# Appendix C NC Serial Communications Protocol

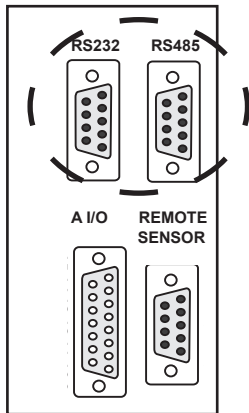

**Note** Appendix C assumes you have a basic understanding of communications protocols. ▲

Connect your PC to the applicable connector on the rear of the chiller. Use the controller, see Section 4, to enable serial communications.

**Note** Keypad operation is still available with serial communications enabled. ▲



**WARNING** Never apply line voltage to any of the connections. ▲

**Figure C-1** Connectors

All data is sent and received in binary form, do not use ASCII. In the following pages the binary data is represented in hexadecimal (hex) format.

The NC Serial Communications Protocol is based on a master-slave model. The master is a host computer, while the slave is the chiller's controller. Only the master can initiate a communications transaction (half-duplex). The slave ends the transaction by responding to the master's query. The protocol uses RS-232/RS-485 serial interface with the default parameters: 9600 baud, 8 data bits, 1 stop bit, and no parity. RS-485 offers a slave address selection, default parameter: 1.

The chiller can be controlled through your computer's serial port by using the chiller's standard female 9-pin connection.

### RS-232 COMM

Pin #	Function
1	No connection
2	TX
3	RX
4	No connection
5	GND = Signal ground
6 - 9	No connection

TX = Transmitted data from controller  
RX = Received data to controller.

### RS-485 COMM

Pin #	Function
1-7	No connection
8	T+
9	T-

**Hardware Mating Connector**  
**AMP Part# 745492-2 or equivalent**

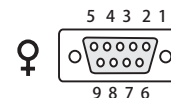

Communication cables are available from Thermo Fisher. Contact us for additional information.

All commands must be entered in the exact format shown in the tables on the following pages. The tables show all commands available, their format and responses. Controller responses are either the requested data or an error message. The controller response *must* be received before the host sends the next command.

The host sends a command embedded in a single communications packet, then waits for the controller's response. If the command is not understood or the checksums do not agree, the controller responds with an error command. Otherwise, the controller responds with the requested data. If the controller fails to respond within 1 second, the host should resend the command.

**Note** All byte values are shown in hex, hex represents the binary values that must be sent to the chiller. **Do not use ASCII.** ▲

The framing of the communications packet in both directions is:

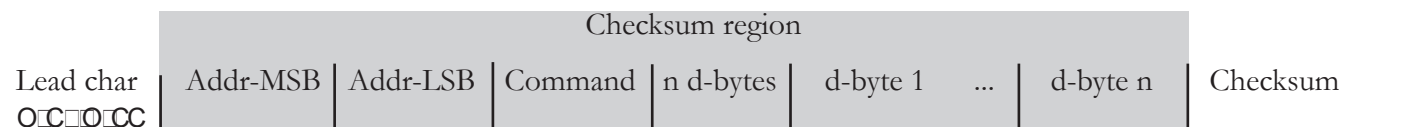

<i>Lead char</i>	<b>0xCA (RS-232) 0xCC (RS-485)</b>
	Device address is 1 (RS-232)
<i>Addr-msb</i>	Most significant byte of slave address (RS-232: 0)
<i>Addr-lsb</i>	Least significant byte of slave address (RS-232: 1)
<i>Command</i>	Command byte (see Table of Commands)
<i>n d-bytes</i>	Number of data bytes to follow
<i>d-byte 1</i>	1 <sup>st</sup> data byte (the qualifier byte is considered a data byte)
...	...
<i>d-byte n</i>	n <sup>th</sup> data byte.
<i>Checksum</i>	Bitwise inversion of the 1 byte sum of bytes beginning with the most significant address byte and ending with the byte preceding the checksum. (To perform a bitwise inversion, "exclusive OR" the one byte sum with FF hex.)

When a command has no value associated with it, (e.g., REQ ACK), "n d-bytes" will be set to 0. Values such as temperature and flow are sent as either 2 or 4 byte signed integers, depending on how they are stored in the controller RAM.

When the controller sends a value, a qualifier byte is sent first, followed by a 2 or 4 byte integer (the least significant byte is sent last). The qualifier indicates the precision and units of the value. The host does not send the qualifier byte; it must send the value using the correct precision, units and number of bytes. The host first inquires about a value it wants to change, then uses the number of data bytes and the qualifier byte it receives to generate the proper integer to send.

**Analog Values**

*Qualifier Byte	
b.7	Precision of measurement
b.6	
b.5	
b.4	
b.3	Unit of measure index
b.2	
b.1	
b.0	

Unit of Measure	
Index	Unit
0	NONE
1	Temperature in °C
2	Temperature in °F
3	Flow liters per minute
4	Flow in gallons per minute
5	Time in seconds
6	Pressure in PSI
7	Pressure in bars
8	Resistivity in MΩ-cm
9	%
10	Volts
11	Pressure in K Pascals
12	Conductivity in μs/cm

E.g., the integer 986 preceded by a qualifier byte of 0x12 is 98.6°F.

Example to set setpoint to 25°C:

If the temperature units are unknown, before changing the setpoint send a command to request setpoint. The response will include both the precision and units. Precision is fixed at 0.1 and units can be either °C or °F. If the units are already known skip to step 3.

1. Master sends: CA 00 01 70 00 8E (REQ SETPOINT1)
2. Slave responds: CA 00 01 70 03 11 00 C8 B2 (0.1°C x 200)  
Response indicates:  
uses a 2 byte integer (nn=03)  
precision and units are 0.1°C (d1=11)
3. Master sends: CA 00 01 F0 02 00 FA 12 (Set Setpoint 1 to 25.0°C)
4. Slave responds: CA 00 01 F0 03 11 00 FA 00 (0.1°C x 250)

See Additional Command Examples in this Appendix.

**Set Commands** – When a Set Command is received and the value is within the allowable limits, the new value will take affect immediately and the new value will be returned as part of the response to the command. If the value is outside of the allowable limits, the value will be rejected and the old value will be returned as part of the response to the command.

**Error Response F0** - The "Bad Data" and "Bad Checksum" error responses will not be used. Reject out of range values and return old settings. Do not reply to message frames with bad checksums. This behavior is compatible with existing implementations of the protocol.



Table of Commands		
Command	M: Master Sends S: Slave Responds	Notes
REQUEST STATUS		
REQ ACK	M: lc a1 a2 <b>00</b> 00 cs S: lc a1 a2 <b>00</b> 02 v1 v2 cs	protocol version v1=0; v2=1
REQ CONTROLLER SW VER	M: lc a1 a2 <b>02</b> 01 d1 cs S: lc a1 a2 <b>02</b> nn d1 ... dn cs	d1 = 0 Controller SW version in ASCII d1 = 1 Controller SW checksum
REQ STATUS	M: lc a1 a2 <b>09</b> 00 cs S: lc a1 a2 <b>09</b> nn d1 ... dn cs	see Request Status Table in this Appendix
ERROR	M: S: lc a1 a2 <b>0F</b> 02 en ed cs	Response Only! ed = Error Data en = Error Number 1: Bad Command See Error in this Appendix
REQUEST MEASUREMENTS		
REQ SETPT1	M: lc a1 a2 <b>70</b> 00 cs S: lc a1 a2 <b>70</b> 03 d1 d2 d3 cs	Process Fluid Setpoint
REQ FLOW1	M: lc a1 a2 <b>10</b> 00 cs S: lc a1 a2 <b>10</b> 03 d1 d2 d3 cs	Process Fluid Flow
REQ TEMP1	M: lc a1 a2 <b>20</b> 00 cs S: lc a1 a2 <b>20</b> 03 d1 d2 d3 cs	Process Fluid Supply Temperature (RTD1)
REQ TEMP2	M: lc a1 a2 <b>21</b> 00 cs S: lc a1 a2 <b>21</b> 03 d1 d2 d3 cs	Process Fluid Return Temperature (RTD2)
REQ TEMP4	M: lc a1 a2 <b>23</b> 00 cs S: lc a1 a2 <b>23</b> 03 d1 d2 d3 cs	Entering Air/Facility Water (RTD4)
REQ TEMP7	M: lc a1 a2 <b>26</b> 00 cs S: lc a1 a2 <b>26</b> 03 d1 d2 d3 cs	ThermoFlex 2500 Air-cooled Fan Speed
REQ ANALOG1	M: lc a1 a2 <b>28</b> 00 cs S: lc a1 a2 <b>28</b> 03 d1 d2 d3 cs	Process Fluid Supply Pressure (P2)
REQ ANALOG2	M: lc a1 a2 <b>29</b> 00 cs S: lc a1 a2 <b>29</b> 03 d1 d2 d3 cs	Refrigeration Suction Pressure (P5)
REQ ANALOG3	M: lc a1 a2 <b>2A</b> 00 cs S: lc a1 a2 <b>2A</b> 03 d1 d2 d3 cs	Process Fluid Return Pressure (P1)
REQ ANALOG4	M: lc a1 a2 <b>2B</b> 00 cs S: lc a1 a2 <b>2B</b> 03 d1 d2 d3 cs	Condensing Pressure (P6)

REQ ANALOG5	M: lc a1 a2 <b>1C</b> 00 cs S: lc a1 a2 <b>1C</b> 03 d1 d2 d3 cs	Facility Inlet Pressure (P7)
REQ ANALOG6	M: lc a1 a2 <b>1D</b> 00 cs S: lc a1 a2 <b>1D</b> 03 d1 d2 d3 cs	Facility Outlet Pressure (P8)
REQ ANALOG7	M: lc a1 a2 <b>1E</b> 00 cs S: lc a1 a2 <b>1E</b> 03 d1 d2 d3 cs	Analog Level (LEV4)
REQ ANALOG9	M: lc a1 a2 <b>2F</b> 00 cs S: lc a1 a2 <b>2F</b> 03 d1 d2 d3 cs	+5V Sense
REQ REMOTE RTD	M: lc a1 a2 <b>1B</b> 00 cs S: lc a1 a2 <b>1B</b> 03 d1 d2 d3 cs	Remote Temperature from Analog Board
REQ RES1	M: lc a1 a2 <b>2C</b> 00 cs S: lc a1 a2 <b>2C</b> 03 d1 d2 d3 cs	Process Fluid Resistivity
REQUEST LOW ALARM VALUES		
REQ LO FLOW1	M: lc a1 a2 <b>30</b> 00 cs S: lc a1 a2 <b>30</b> 03 d1 d2 d3 cs	Process Warning
REQ LO FLOW3	M: lc a1 a2 <b>32</b> 00 cs S: lc a1 a2 <b>32</b> 03 d1 d2 d3 cs	Process Fault
REQ LO ANALOG1	M: lc a1 a2 <b>48</b> 00 cs S: lc a1 a2 <b>48</b> 03 d1 d2 d3 cs	Pressure Process Supply Warning
REQ LO ANALOG2	M: lc a1 a2 <b>49</b> 00 cs S: lc a1 a2 <b>49</b> 03 d1 d2 d3 cs	Pressure Process Supply Fault
REQ LO ANALOG7	M: lc a1 a2 <b>3E</b> 00 cs S: lc a1 a2 <b>3E</b> 03 d1 d2 d3 cs	Level Warning
REQ LO ANALOG8	M: lc a1 a2 <b>3F</b> 00 cs S: lc a1 a2 <b>3F</b> 03 d1 d2 d3 cs	Level Fault
REQ LO TEMP1	M: lc a1 a2 <b>40</b> 00 cs S: lc a1 a2 <b>40</b> 03 d1 d2 d3 cs	Process Warning
REQ LO TEMP2	M: lc a1 a2 <b>41</b> 00 cs S: lc a1 a2 <b>41</b> 03 d1 d2 d3 cs	Process Fault
REQ AUTO REFILL ON	M: lc a1 a2 <b>45</b> 00 cs S: lc a1 a2 <b>45</b> 03 d1 d2 d3 cs	Auto refill On Setting
REQ LO RES1	M: lc a1 a2 <b>4C</b> 00 cs S: lc a1 a2 <b>4C</b> 03 d1 d2 d3 cs	Process Warning

## REQUEST HIGH ALARM VALUES

REQ HI FLOW1	M: lc a1 a2 <b>50</b> 00 cs S: lc a1 a2 <b>50</b> 03 d1 d2 d3 cs	Process Warning
REQ HI FLOW3	M: lc a1 a2 <b>52</b> 00 cs S: lc a1 a2 <b>52</b> 03 d1 d2 d3 cs	Process Fault
REQ HI TEMP1	M: lc a1 a2 <b>60</b> 00 cs S: lc a1 a2 <b>60</b> 03 d1 d2 d3 cs	Process Warning
REQ HI TEMP2	M: lc a1 a2 <b>61</b> 00 cs S: lc a1 a2 <b>61</b> 03 d1 d2 d3 cs	Process Fault
REQ HI ANALOG1	M: lc a1 a2 <b>68</b> 00 cs S: lc a1 a2 <b>68</b> 03 d1 d2 d3 cs	Pressure Process Supply Warning
REQ HI ANALOG2	M: lc a1 a2 <b>69</b> 00 cs S: lc a1 a2 <b>69</b> 03 d1 d2 d3 cs	Pressure Process Supply Fault
REQ HI RES1	M: lc a1 a2 <b>6C</b> 00 cs S: lc a1 a2 <b>6C</b> 03 d1 d2 d3 cs	Process Warning

## REQUEST PID SETTINGS

REQ COOL P	M: lc a1 a2 <b>74</b> 00 cs S: lc a1 a2 <b>74</b> 03 d1 d2 d3 cs
REQ COOL I	M: lc a1 a2 <b>75</b> 00 cs S: lc a1 a2 <b>75</b> 03 d1 d2 d3 cs
REQ COOL D	M: lc a1 a2 <b>76</b> 00 cs S: lc a1 a2 <b>76</b> 03 d1 d2 d3 cs
REQ HEAT P	M: lc a1 a2 <b>71</b> 00 cs S: lc a1 a2 <b>71</b> 03 d1 d2 d3 cs
REQ HEAT I	M: lc a1 a2 <b>72</b> 00 cs S: lc a1 a2 <b>72</b> 03 d1 d2 d3 cs
REQ HEAT D	M: lc a1 a2 <b>73</b> 00 cs S: lc a1 a2 <b>73</b> 03 d1 d2 d3 cs

## SET STATUS SETTINGS

SET KEYSTROKE	M: lc a1 a2 <b>80</b> 01 d1 cs S: lc a1 a2 <b>80</b> 01 d1 cs	See Set Keystroke in this Appendix
SET ON/OFF ARRAY	M: lc a1 a2 <b>81</b> nn d1 ... dn cs S: lc a1 a2 <b>81</b> nn d1 ... dn cs	See Set On/Off Array in this Appendix di: 0 = OFF, 1 = ON, 2 = no change

## SET MEASUREMENT

SET SETPT1	M: lc a1 a2 <b>F0</b> 02 d1 d2 cs S: lc a1 a2 <b>F0</b> 03 d1 d2 d3 cs	Process Fluid Setpoint
------------	---	------------------------

## SET LOW ALARM VALUES

SET LO FLOW1	M: lc a1 a2 <b>B0</b> 02 d1 d2 cs S: lc a1 a2 <b>B0</b> 03 d1 d2 d3 cs	Process Warning
SET LO FLOW3	M: lc a1 a2 <b>B2</b> 02 d1 d2 cs S: lc a1 a2 <b>B2</b> 03 d1 d2 d3 cs	Process Fault
SET LO TEMP1	M: lc a1 a2 <b>C0</b> 02 d1 d2 cs S: lc a1 a2 <b>C0</b> 03 d1 d2 d3 cs	Process Warning
SET LO TEMP2	M: lc a1 a2 <b>C1</b> 02 d1 d2 cs S: lc a1 a2 <b>C1</b> 03 d1 d2 d3 cs	Process Fault
SET LO ANALOG1	M: lc a1 a2 <b>C8</b> 02 d1 d2 cs S: lc a1 a2 <b>C8</b> 03 d1 d2 d3 cs	Pressure Process Supply Warning
SET LO ANALOG2	M: lc a1 a2 <b>C9</b> 02 d1 d2 cs S: lc a1 a2 <b>C9</b> 03 d1 d2 d3 cs	Pressure Process Supply Fault
SET LO ANALOG7	M: lc a1 a2 <b>BE</b> 02 d1 d2 cs S: lc a1 a2 <b>BE</b> 03 d1 d2 d3 cs	Level Warning
SET LO ANALOG8	M: lc a1 a2 <b>BF</b> 02 d1 d2 cs S: lc a1 a2 <b>BF</b> 03 d1 d2 d3 cs	Level Fault
SET AUTO REFILL ON	M: lc a1 a2 <b>C5</b> 02 d1 d2 cs S: lc a1 a2 <b>C5</b> 03 d1 d2 d3 cs	When level % drops below this, turn on auto refill
SET LO RES1	M: lc a1 a2 <b>CC</b> 02 d1 d2 cs S: lc a1 a2 <b>CC</b> 03 d1 d2 d3 cs	Process Warning
SET LO RES1	M: lc a1 a2 <b>CD</b> 02 d1 d2 cs S: lc a1 a2 <b>CD</b> 03 d1 d2 d3 cs	Process Fault

## SET HIGH ALARM VALUES

SET HI FLOW1	M: lc a1 a2 <b>D0</b> 02 d1 d2 cs S: lc a1 a2 <b>D0</b> 03 d1 d2 d3 cs	Process Warning
SET HI FLOW3	M: lc a1 a2 <b>D2</b> 02 d1 d2 cs S: lc a1 a2 <b>D2</b> 03 d1 d2 d3 cs	Process Fault
SET HI TEMP1	M: lc a1 a2 <b>E0</b> 02 d1 d2 cs S: lc a1 a2 <b>E0</b> 03 d1 d2 d3 cs	Process Warning
SET HI TEMP2	M: lc a1 a2 <b>E1</b> 02 d1 d2 cs S: lc a1 a2 <b>E1</b> 03 d1 d2 d3 cs	Process Fault
SET HI ANALOG1	M: lc a1 a2 <b>E8</b> 02 d1 d2 cs S: lc a1 a2 <b>E8</b> 03 d1 d2 d3 cs	Pressure Process Supply Warning
SET HI ANALOG2	M: lc a1 a2 <b>E9</b> 02 d1 d2 cs S: lc a1 a2 <b>E9</b> 03 d1 d2 d3 cs	Pressure Process Supply Fault
SET HI ANALOG7	M: lc a1 a2 <b>DE</b> 02 d1 d2 cs S: lc a1 a2 <b>DE</b> 03 d1 d2 d3 cs	Level Warning
SET HI ANALOG8	M: lc a1 a2 <b>DF</b> 02 d1 d2 cs S: lc a1 a2 <b>DF</b> 03 d1 d2 d3 cs	Level Fault
SET AUTO REFILL OFF	M: lc a1 a2 <b>E5</b> 02 d1 d2 cs S: lc a1 a2 <b>E5</b> 03 d1 d2 d3 cs	When level % drops below this, turn off auto refill
SET HI RES1	M: lc a1 a2 <b>EC</b> 02 d1 d2 cs S: lc a1 a2 <b>EC</b> 03 d1 d2 d3 cs	Process Warning
SET HI RES2	M: lc a1 a2 <b>ED</b> 02 d1 d2 cs S: lc a1 a2 <b>ED</b> 03 d1 d2 d3 cs	Process Fault
SET PID SETTINGS		
SET COOL P	M: lc a1 a2 <b>F4</b> 02 d1 d2 cs S: lc a1 a2 <b>F4</b> 03 d1 d2 d3 cs	Cool P Term
SET COOL I	M: lc a1 a2 <b>F5</b> 02 d1 d2 cs S: lc a1 a2 <b>F5</b> 03 d1 d2 d3 cs	Cool I Term
SET COOL D	M: lc a1 a2 <b>F6</b> 02 d1 d2 cs S: lc a1 a2 <b>F6</b> 03 d1 d2 d3 cs	Cool D Term
SET HEAT P	M: lc a1 a2 <b>F1</b> 02 d1 d2 cs S: lc a1 a2 <b>F1</b> 03 d1 d2 d3 cs	Heat P Term
SET HEAT I	M: lc a1 a2 <b>F2</b> 02 d1 d2 cs S: lc a1 a2 <b>F2</b> 03 d1 d2 d3 cs	Heat I Term
SET HEAT D	M: lc a1 a2 <b>F3</b> 02 d1 d2 cs S: lc a1 a2 <b>F3</b> 03 d1 d2 d3 cs	Heat D Term

## Request Status Table

nn	4				
	b0	Chiller Running		b0	HTC (High Temperature Cutout)
	b1	Chiller Faulted		b1	LLC (Low Level Cutout)
	b2	Process Supply RTD open or shorted		b2	MOL (Motor Overload)
d1	b3	Process Return RTD open or shorted	d3	b3	Phase Monitor
	b4	Suction RTD open or shorted		b4	HPC (High Pressure Cutout)
	b5	Entering Air or Facility Water RTD open or shorted		b5	LPC (Low Pressure Cutout)
	b6	High Temp Error		b6	EMO
	b7	Low Temp Error		b7	External EMO
	b0	High Pressure Error		b0	RA T_MAX (High Temperature)
	b1	Low Pressure Error		b1	Not used
	b2	High Flow Error (user set able)		b2	Auto Refill Valve Open
d2	b3	Low Flow Error (user set able)	d4	b3	Anti Drainback Valve Open
	b4	High Level Error		b4	Clogged Fluid Filter Fault
	b5	Low Level Error		b5	Temp Fault Startup Bypass
	b6	Drip Pan fault		b6	System Low Flow
	b7	Auto Refill fault		b7	Not used

**Error**

The slave detected an error in the message it received from the master, so it returns this command instead of echoing the command sent by the master. The slave returns the command it received from the master in the ed byte, and an error code in the en byte.

en	Error
1	Bad command – not recognized by slave
2	Reject value and return old setting
3	Do not respond at all

Some errors may not result in any response. The slave ignores incoming bytes until it sees the valid lead character and its slave address. Then it must receive the correct number of bytes (determined by the length byte) before it can respond. If an incomplete frame is received, the slave will time out and clear its input buffer without responding.

**Set On/Off Array**

This command is used to set the state of the chiller on or off. Sending a 0 in the array turns off the chiller while sending a 1 turns it on. Sending a 2 does not change the state of the feature. The array is returned showing the state of each feature after the command has been carried out. Sending a 2 effectively turns this command into a request status command.

nn	1
d1	Chiller On/Off

**Set Keystroke**

This command is used to affect a keystroke remotely as if someone pressed the button on the controller.

Value	
0	Null
1	Enter
2	Up/Yes
3	Down/No
4	Esc
5	On/Off
6	Left
7	Right



## Set Special Command

Used for product specific commands, in the ThermoFlex this command configures the analog options (DAC out, Analog in and turns on and off DAC output)

CA 00 01 8D nn d1...dn cs

### Set Special Command

Byte		Notes
d1	Command Byte	Indicates what command
d2	Description Byte	See description below
d3	Entered Value if necessary	

### Command Byte

Command	Description
00	Set Analog Option
01	Set Resistivity Control (for basic derivatives)
02	Unused

### Description Byte

Byte	Notes	
b.7 - b.6	Unused	
b.5 and b.4	Remote DAC output enable	00 = Off, 01 = On, 1x = No Change
b.3 - b.2	Configure DAC Output	00h = Volt, 01h = millivolt, 02h = milliamp, 03h = No Change
b.1 - b.2	Configure Analog Input	00h = Volt, 01h = millivolt, 02h = milliamp, 03h = No Change

The following command string example enables the DAC output, configures the DAC for millivolts and configures the analog input for voltage:

CA 00 01 8D 02 00 14 cs



# Appendix D Analog I/O and Remote Sensor

## Analog I/O Connector Pinout ♀

Install your analog input/output device to the 15-pin female connector on the rear of the chiller. Analog I/O is activated using the controller, see Section 4.

PIN	NAME	NOTES	DEFINITION
1	DIGITAL GROUND		Common round connection for pins 12, 13 and 14
2	RESISTIVITY OUT	Optional	Analog voltage output 0v = 0 MΩ - cm 10v = 20 MΩ - cm
3	LOW LEVEL (Only if option chosen)	Note 1	<u>Dry Relay Contact</u> : Reference to pin 11. Closes if either level switch is in the "low" position for more than 1 second.
4	CONFIGURABLE RELAY 2	Note 1	<u>Dry Relay Contact</u> : Reference to pin 11. Closes when any configured fault or warning occurs.
5	PUMP ON	Note 1	<u>Dry Relay Contact</u> : Reference to pin 11. Closes when pump is turned on. Opens when pump is turned off.
6	ANALOG GROUND		Common for analog signals (pins 2, 7 and 15)
7	RESERVOIR TEMP OUT <b>OR</b> EXTERNAL SENSOR TEMPERATURE IF EXTERNAL SENSOR ENABLED	Note 2	Analog Voltage Output 0-10VDC, 10mV/°C, or 4-20mA: Reference to pin 6. This voltage output is proportional to the reservoir fluid temperature: Default scale= 0–10V (where: 0V = Low Temp Span, 10V = Hi Temp Span) Optional Range = 10mV/ °C. (Ex: 200mV = 20°C) (Max Load @ 10V = 5mA) or 4-20mA, 4mA = low temp span, 20 mA = high temp span (maximum output current = 5mA @10VDC.
8	LOW FLOW (Only if option chosen)	Note 1	<u>Dry Relay Contact</u> : Reference to pin 11. Closes when a low flow occurs while the pump is on. Note: To allow the pump to get up to speed at startup, the pump runs for 3 - 5 seconds before the low flow sensor is read.
9	CONFIGURABLE RELAY 1 (Normally Open)	Note 1	<u>Dry Relay Contact</u> : Reference to pin 11. Closes when any of the configured faults occur.
10	CONFIGURABLE RELAY 1 (Normally Closed)	Note 1	<u>Dry Relay Contact</u> : Reference to pin 11. Complement of pin 9 (open when pin 9 is closed).
11	RELAY COMMON		Common for all relay contacts (pins 3, 4, 5, 8, 9, 10).
12	REMOTE START ENABLE	Note 3	Connect to pin 1 to allow chiller to be remotely turned on/off through pin 14 REMOTE START.

Note 1: All relay contacts (except for Pin 10) are normally OPEN when power is off. Pin 10 contacts are normally CLOSED when power is off. Relay contacts are rated: 24V AC/DC, 2A, <= 0.08 Ohm maximum each or 5A total for all relays combined, 1mA minimum, switching capacity: 48VA/48W (Resistive load only).

Note 2: Default = 0-10VDC. These ranges are set by the user.

Note 3: Connect to digital ground (pin 1) using a low resistance connection (gold contact relay).

PIN	NAME	NOTES	DEFINITION
13	REMOTE SETPOINT ENABLE	Note 3	Connect to pin 1 to allow the setpoint to be changed remotely through pin 15 REMOTE SETPOINT.
14	REMOTE START	Note 3	Connect to pin 1 to turn chiller on. Disconnect to turn chiller off. Note: Pins 1 and 12 must be connected to allow operation from this pin.
15	REMOTE SETPOINT	Note 2, 4	Analog Voltage Input 0-10VDC, 10mV/°C, or 4-20mA: Reference to pin 6. Apply a DC voltage to this pin to adjust the setpoint: Default Range = 0 – 10V (where: 0V = Low Temp Span, 10V = Hi Temp Span) (Input Impedance > 600K) Optional Range = 10mV/°C. (Ex: 200mV = 20°C) (Max Input Voltage = 10VDC, or 4-20mA, 4mA = low temp span, 20 mA = high temp span.

Note 1: All relay contacts (except for Pin 10) are normally OPEN when power is off. Pin 10 contacts are normally CLOSED when power is off. Relay contacts are rated: 24V AC/DC, 2A, <= 0.08 Ohm maximum each or 5A total for all relays combined, 1mA minimum, switching capacity: 48VA/48W (Resistive load only).

Note 2: Default = 0-10VDC. These ranges are set by the user.

Note 3: Connect to digital ground (pin 1) using a low resistance connection (gold contact relay).

Note 4: Remote setpoint must be enabled, pin 13

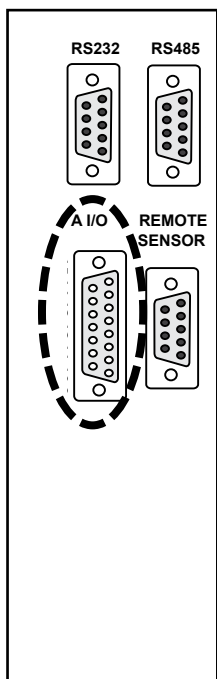

**WARNING** Never apply line voltage to any of the connections. ▲

When making your connection to the ThermoFlex Analog I/O connector, in order to comply with the EMC directive:

- Use a shielded I/O cable
- Connect the remote end of the cable shield to earth ground.
- Connect cable shield to ThermoFlex end connector.

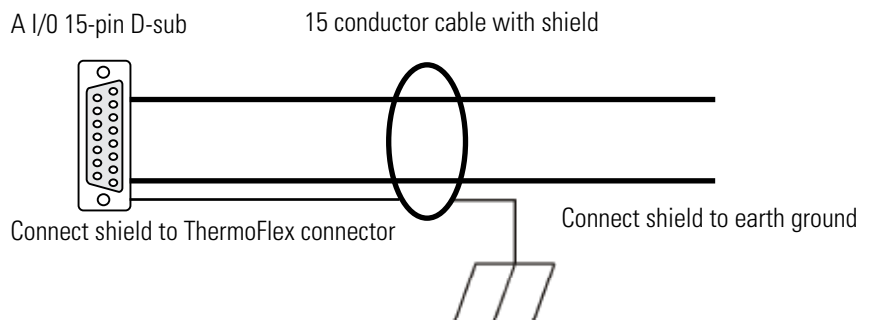

**Figure D-1** Analog I/O Connector

## Analog Comm and Configurable Relays

Use the up/down arrows to scroll through the entire menu (only six lines are displayed at a time). When any desired feature is highlighted press enter to select it. Enabled features are indicated by .

ANALOG COMM - ACOM	
<input checked="" type="checkbox"/> Remote Sensor	
<input type="checkbox"/> Remote Start	
<input type="checkbox"/> Remote Setpt	volts
<input type="checkbox"/> Temp Out	volts
⏠	
-----	
Remote Start	
Remote Setpt	volts

**Note** Enabling analog I/O remote start/stop disables the chiller's local controller start/stop capability. Enabling analog I/O remote also overrides serial communications start/stop commands. ▲

To change the **Remote Setpoint** or **Temp Out** input type use the up and down arrows until the input is highlighted. (The left and right arrows have no affect in moving the highlight.)

ANALOG COMM - ACOM	
<input type="checkbox"/> Remote Sensor	
<input type="checkbox"/> Remote Start	
<input type="checkbox"/> Remote Setpt	volts
<input type="checkbox"/> Temp Out	volts
⏠	

Press enter to get the input type to flash. Use the up and down arrows to bring up the desired input: **volts**, **mv** or **ma**. With the desired input displayed press enter again to accept the change.

With **RELAY1** or **RELAY2** highlighted press enter to bring up the corresponding **RELAY** display. Highlight the desired error(s) and press enter. Enabled errors are indicated by .

**Note** Except for **Warning**, errors will automatically clear once the condition is corrected. **Warning** also requires pressing enter once the condition is corrected.

RELAY 1	
<input checked="" type="checkbox"/> Low Level	
<input type="checkbox"/> Tank Overflow	
<input type="checkbox"/> Drip Pan Full	
<input type="checkbox"/> Low Temperature	
⏠	
-----	
<input type="checkbox"/> High Temperature	
<input checked="" type="checkbox"/> Low Flow	
<input type="checkbox"/> High Flow	
<input type="checkbox"/> Low Resistivity	
<input type="checkbox"/> High Resistivity	
<input type="checkbox"/> High Pressure	
<input type="checkbox"/> Low Pressure	
<input checked="" type="checkbox"/> Unit Fault	
<input type="checkbox"/> Pump/Unit Shut Off	
<input type="checkbox"/> Refrig. Shut Off	
<input checked="" type="checkbox"/> Limit Fault	
<input type="checkbox"/> Sensor Fault	

RELAY 2	
<input type="checkbox"/> Low Level	
<input type="checkbox"/> Tank Overflow	
<input type="checkbox"/> Drip Pan Full	
<input type="checkbox"/> Auto Refill Error	
⏠	
-----	
<input checked="" type="checkbox"/> Low Temperature	
<input checked="" type="checkbox"/> High Temperature	
<input type="checkbox"/> Low Flow	
<input type="checkbox"/> High Flow	
<input type="checkbox"/> Low Resistivity	
<input checked="" type="checkbox"/> High Resistivity	
<input type="checkbox"/> High Pressure	
<input type="checkbox"/> Low Pressure	
<input type="checkbox"/> Warning	
<input type="checkbox"/> PM Timer	
<input type="checkbox"/> Comm Error	
<input checked="" type="checkbox"/> Sensor Fault	

## USER RANGE SETTINGS

This menu allows the you to customize the scaling of the analog input and DAC output to meet the application needs. With **USER RANGE SETTINGS** highlighted press enter to display:

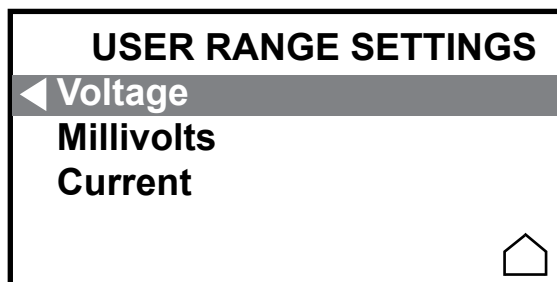

The ThermoFlex supports three standard analog interface types and defaults to the following scaling:

<b>Voltage</b>	□□□ 1□□□ the operating range of the chiller □□° □ 4□° in standard chillers □□° □ □□° in high temp chillers □
<b>MilliVolts</b>	1□m□°C
<b>Current</b>	4ma □ □□ma □ the operating range of the chiller

The following values reflect the standard scaling and are the factory defaults:

**Voltage (0v – 10v = the operating range of the chiller)**

<b>High volts</b>	<b>10.0v</b>
<b>Low volts</b>	<b>0.0v</b>
<b>High temp</b>	<b>40.0° (standard temp chillers), 90.0° (high temp chillers)</b>
<b>Low temp</b>	<b>5.0°</b>

With **Voltage** highlighted press enter to display:

USER VOLTAGE	
◀ High Volts	10.0
Low Volts	0.0
High Temp	40.0
Low Temp	5.0

Highlight the desired value and then press enter, the highlight will flash. Use the up and down arrows to change the value. Once the desired value is displayed press enter to accept the change and stop the flashing.

These values are used to calculate a gain and offset and are applied to the setpoint input voltage.

oltageInputGain  high temp  low temp  high olt  low olt   
oltageInputOffset  high temp  high olt oltageInputGain

The default settings for a high temp chiller will yield the following gain and offset for setpoint input:

oltageInputGain  1000  00001  0000    
oltageInputOffset  000  1000000

ow 100 will yield a setpoint of 00°. 100 gain offset  
 000000000000

It could just as easily be configured for other ranges such as:

1000000° 1000°. However the chiller will only recognize a set point between 0° 000°.

A separate gain and offset is also be calculated and are applied to the DAC temperature output value.

oltageOutputGain  high olt  low olt  high temp  low temp   
oltageOutputOffset  high olt  high temp oltageOutputGain

The default settings for a high temp chiller will yield the following gain and offset for temperature output:

oltageOutputGain  1000000000000  117647  
oltageOutputOffset  1000000000000  1176470000000000

ow 00° will output 1000000000000 gain offset  
 000000000000 1000000000000



The following values are the factory defaults for the millivolt setting that will effectively yield 10mv/°C:

**MilliVolts (10mv/°C)**

<b>High mv</b>	<b>1000.0mv</b>
<b>Low mv</b>	<b>0.0mv</b>
<b>High temp</b>	<b>100.0°</b>
<b>Low temp</b>	<b>0.0°</b>

With **Millivolts** highlighted press enter to display:

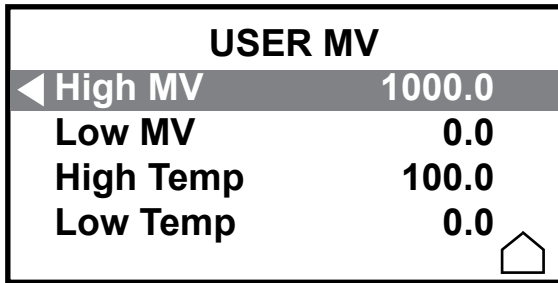

Highlight the desired value and then press enter, the highlight will flash. Use the up and down arrows to change the value. Once the desired value is displayed press enter to accept the change and stop the flashing.

These values are used to calculate a gain and offset and are applied to the set point input voltage.

$$\text{MillioltInputGain} = \frac{\text{high temp} - \text{low temp}}{\text{high m} - \text{low m}}$$

$$\text{MillioltInputOffset} = \text{high temp} - \text{high m} \times \text{MillioltInputGain}$$

So that the default settings will yield the following gain and offset for set point input:

$$\text{MillioltInputGain} = \frac{100 - 0}{1000 - 0} = 0.1$$

$$\text{MillioltInputOffset} = 100 - 1000 \times 0.1 = 0$$

low 100m will yield a set point of 100° gain 0.1 offset 0  
 100m 100 100 100 100 100m°C

Just like voltage the mv range can be set for other ranges.

A separate gain and offset will also be calculated and are applied to the DAC temperature output value.

$$\text{MillioltOutputGain} = \frac{\text{high m} - \text{low m}}{\text{high temp} - \text{low temp}}$$

$$\text{MilioltOutputOffset} = \text{high m} - \text{high temp} \times \text{MillioltOutputGain}$$

So that the default settings will yield the following gain and offset for temperature output.

$$\text{MillioltOutputGain} = \frac{1000 - 0}{100 - 0} = 10$$

$$\text{MillioltOutputOffse} = 1000 - 100 \times 10 = 0$$

low 100° will output 1000m gain 10 offset 0  
 100 1000 100 100m 100m°C

The following values reflect the standard scaling and are the factory defaults:

**Current (4ma – 20ma = the operating range of the chiller)**

<b>High ma</b>	<b>20.0ma</b>
<b>Low ma</b>	<b>4.0ma</b>
<b>High temp</b>	<b>40.0° (standard temp chillers) 90.0° (high temp chillers)</b>
<b>Low temp</b>	<b>5.0°</b>

With **Current** highlighted press enter to display:

USER MA	
◀ High MA	20.0
Low MA	4.0
High Temp	40.0
Low Temp	5.0

Highlight the desired value and then press enter, the highlight will flash. Use the up and down arrows to change the value. Once the desired value is displayed press enter to accept the change and stop the flashing.

Calculating the default gain and offset for set point input for a high temp chiller:

$$\text{Milli}\square\text{mpInputGain} \square \text{high temp} \square \text{low temp} \square \square \text{high ma} \square \text{low ma} \square$$

$$\text{Milli}\square\text{mpInputOffset} \square \text{high temp} \square \text{high ma} \square \text{Milli}\square\text{mpInputGain} \square$$

The default settings for a high temp chiller will yield the following gain and offset for setpoint input:

$$\text{Milli}\square\text{mpInputGain} \square \square\square.\square \square \square.\square\square\square\square\square\square \square \square 4.\square\square \square \square 1 \square\square$$

$$\text{Milli}\square\text{mpInputOffset} \square \square \square \square \square \square 1 \square\square\square\square\square\square \square 16.\square\square$$

$$\square \text{ow} \square \text{ma will represent a setpoint of} \square \square \square$$

$$\square\square.\square \square \square \square 1 \square\square\square\square \square 16.\square\square \square \square \square$$

A separate gain and offset will also be calculated and are be applied to the DAC temperature output value.

$$\text{Milli}\square\text{mpOutputGain} \square \text{high ma} \square \text{low ma} \square \square \text{high temp} \square \text{low temp} \square$$

$$\text{Milli}\square\text{mpOutputOffset} \square \text{high ma} \square \text{high temp} \square \text{Milli}\square\text{mpOutputGain} \square$$

The default settings for a high temp chiller will yield the following gain and offset for temperature output:

$$\text{Milli}\square\text{mpOutputGain} \square \square\square.\square \square 4.\square\square\square\square\square \square \square \square \square 1 \square\square\square\square\square\square 4$$

$$\text{Milli}\square\text{mpOutputOffset} \square \square \square \square \square \square 1 \square\square\square\square\square\square \square \square \square\square\square\square\square\square$$

$$\square \text{ow} \square \square \square \square \text{ma temperature output.}$$

$$\square\square \square \square 1 \square\square\square\square\square\square 4 \square \square \square \square \square\square\square\square\square \square \square \text{ma}$$

**Note:** Ensure that there is sufficient range in the voltage or current to provide enough resolution of temperature. For example a voltage range of 0v – 1v to represent a temperature range of 0° - 150° would not have enough resolution to provide stable readings.

# Remote Sensor Connector Pinout

**Table 1**

Pin	Color
1	White
2	NA
3	NA
4	White
5	NA
6	NA
7	Red
8	NA
9	Red (4th wire not connected to the control board)

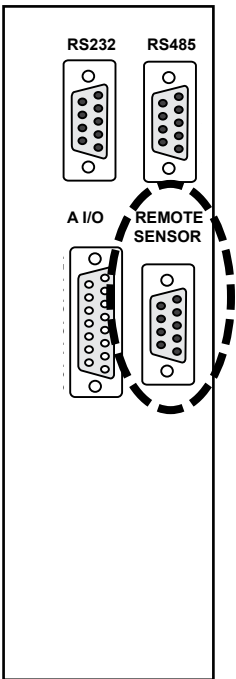
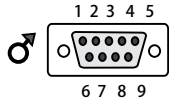

**Never apply line voltage to any of the connections. ▲**



When operating a ThermoFlex7500-10000 with the remote sensor enabled ensure the chiller's response to lowering the setpoint does not result in operation below 10°C process temperature. Operation below 10°C requires the use of 50/50 EG/water or 50/50 PG/water. ▲

**Figure D-2** Remote Sensor Connector

## Remote Sensor Calibration

This procedure requires a running chiller and a calibrated reference thermometer.

**Note** If it is more convenient, perform the low-end calibration before doing the high-end. ▲

Do not pick calibration points that are outside the safe operating limits of the fluid in your application. For example with water, 40°C and 10°C are typical high and low calibration points.

Place the remote sensor and a calibrated reference thermometer in the high temperature remote reservoir. Ensure the fluid temperature is stabilized.

**Note** The remote sensor menu is accessible by navigating with the up or down arrows after selecting **Cal.**

Select which point to calibrate, **Low** or **High**. Press enter and enter the value as read by the reference device. Press enter. Select **Cal.** to the right of the value just entered by pressing the down button. Press enter and note that the **Current** value now equals the value just entered.

1. Highlight **CALIBRATION**.

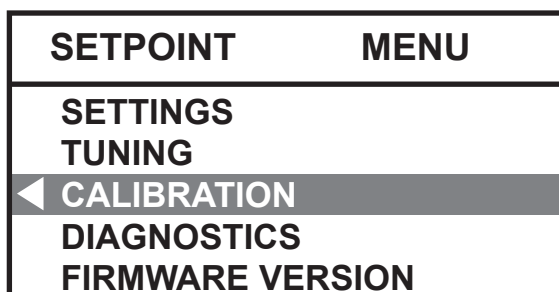

2. Press enter and highlight **CALIBRATE**.

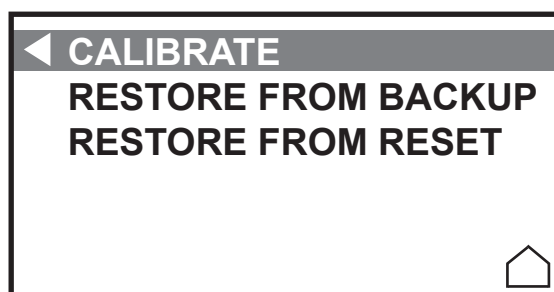

3. Press enter and scroll down or up to display:

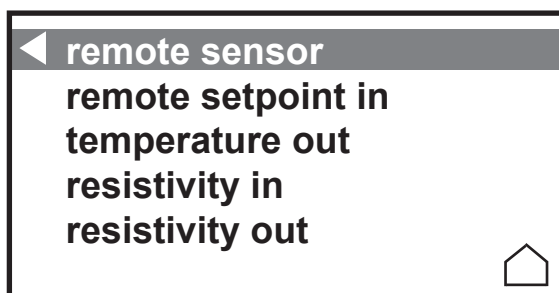

4. Highlight the desired sensor then press enter to display:

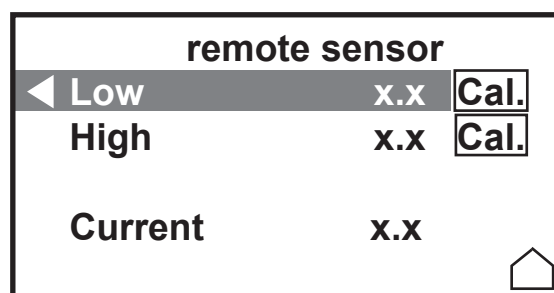



**[1] Manufacturer**

Thermo Fisher Scientific  
25 Nimble Hill Rd  
Newington, NH 03801  
USA

**[2] Authorized Representative**

Thermo Electron LED GmbH  
Robert-Bosch-Str. 1  
63505 Langenselbold  
Germany

**[3] Product Type**

ThermoFlex product line of chillers and heat exchangers for process flow applications

**[4] Model Name(s)**

Unit has a 15-digit or 16-digit part numbers defined on pages 2-3 of this document.

**[5] Rated Voltage, Rated Frequency**

Voltage ratings are reflected as part of the Model Name, defined on the following pages of this document.

[6] The object of the declaration described above is in conformity with the relevant Union harmonization legislation:

**[7] EC Directives**

2014/30/EU	Electromagnetic Compatibility Directive
2014/35/EU	Low Voltage Directive
2011/65/EU	RoHS Directive

[8] The object of the declaration described above is in conformity with Directive 2011/65/EU of the European Parliament and of the Council of 8 June 2011 on the restriction of the use of certain hazardous substances in electrical and electronic equipment.

**[9] Standards**

EN 61326-1:2013  
EN 61010-1:2010, EN 61010-2-010:2014, EN 61010-2-011:2017  
EN 50581:2012

[10] This declaration is valid from the product manufactured after the date.

**28 September, 2018**



---

Mark Pearson  
Global Regulatory Affairs Director  
Laboratory Products Division  
Thermo Fisher Scientific

**Model and Voltage Number Definition :**

Unit has a 15-digit part number consisting of UU C VV PP c XXXXXXX as follows:

UU = unit type can be:

10= TF900	11= TF1400	12= TF2500	13= TF3500	14= TF5000
15= TF7500	16= TF10000	17= TF15000	18= TF20000	19= TF24000

C = Cooling type and Temperature Range where: A/C= Air-cooled, W/C-Water-cooled

1 - A/C Std Temp 5-40C,	2 - A/C Hi Temp 5-90C	3 - W/C Std Temp 5-40C	4 - W/C Hi Temp 5-90C
5 - A/C Temp -5 to 90C	6 - W/C Temp -5 to 90C	7 - A/C Temp -5 to 40C	8 - W/C Temp -5 to 40C
A - Hi Temp No Cooling	B - A/C Temp -5 to 55C	C - W/C Temp -5 to 55C	

VV = Voltage Ratings:

Single Phase:

Three Phase:

10 = 115V/60Hz,	100V/50Hz	17 = (200/208/230V)/60Hz,	200V/50Hz
11 = (100/115V)/60Hz,	(100/115V)/50Hz	18 = 400V/50Hz	
12 = (208/230V)/60Hz,	200V/50Hz	20 = (200/208/230V)/60Hz,	(200-230V)/50Hz
16 = 230V/50Hz		21 = 460V/60Hz,	400V/50Hz
20 = (200/208/230V)/60Hz,	(200/230V)/50Hz		

PP = Pump type, can be 10 through 40 inclusive.

c = Controller type. Can be any digit from 1-8, inclusive.

X = Any digit from 0-9, used as sequential numbering only.



16-digit part number consisting of UU C V P c XXXXXXXX defined as follows:

UU = unit type can be:

10= TF900	11= TF1400	12= TF2500	13= TF3500	14= TF5000
15= TF7500	16= TF10000	17= TF15000	18= TF20000	19= TF24000

C = Cooling type and Temperature Range where: A/C= Air-cooled, W/C-Water-cooled

1 - A/C Std Temp 5-40C	2 - A/C Hi Temp 5-90C	3 - W/C Std Temp 5-40C	4 - W/C Hi Temp 5-90C
5 - A/C Temp -5 to 90C	6 - W/C Temp -5 to 90C	7 - A/C Temp -5 to 40C	8 - W/C Temp -5 to 40C
A - Hi Temp No Cooling	B - A/C Temp -5 to 55C	C - W/C Temp -5 to 55C	D - W/C Temp 5 to 80C

V = Voltage Ratings:

Single Phase:		Three Phase:	
1 = 115V/60Hz,	100V/50Hz	5 = (200/208/230V)/60Hz,	200V/50Hz
2 = (100/115V)/60Hz,	(100/115V)/50Hz	6 = 400V/50Hz	
3 = (208/230V)/60Hz,	200V/50Hz	8 = 460V/60Hz,	400V/50Hz
4 = 230V/50Hz			
7 = (200-230V)/60Hz,	(200-230V)/50Hz		

P = Pump type, can be 0-9 or A-Z.

c = Controller type. Can be any digit from 1-6, inclusive.

X = Any alphanumeric character 0-9 or A-Z.

<p><b>DE</b> <sup>[1]</sup> Hersteller - <sup>[2]</sup> Bevollmächtigter Vertreter - <sup>[3]</sup> Produkttyp - <sup>[4]</sup> Modellbezeichnung(en) - <sup>[5]</sup> Nennspannung, Nennfrequenz – <sup>[6]</sup> Der oben beschriebene Gegenstand der Erklärung erfüllt die einschlägigen Harmonisierungsrechtsvorschriften der Union.: <sup>[7]</sup> EG-Richtlinien - <sup>[8]</sup> Der oben beschriebene Gegenstand der Erklärung erfüllt die Vorschriften der Richtlinie 2011/65/EU des Europäischen Parlaments und des Rates vom 8. Juni 2011 zur Beschränkung der Verwendung bestimmter gefährlicher Stoffe in Elektro- und Elektronikgeräten: <sup>[9]</sup> Normen - <sup>[10]</sup> Diese Erklärung gilt für die nach diesem Datum hergestellten Produkte. <sup>[10]</sup> Diese Erklärung gilt für das Produkt mit folgender Seriennummer und Herstellungsdatum</p>
<p><b>FR</b> <sup>[1]</sup> Fabricant - <sup>[2]</sup> Représentant agréé - <sup>[3]</sup> Type de produit - <sup>[4]</sup> Désignation(s) du modèle - <sup>[5]</sup> Tension nominale, Fréquence nominale – <sup>[6]</sup> L'objet de la déclaration décrit ci-dessus est conforme à la législation d'harmonisation de l'Union applicable : <sup>[7]</sup> Directives européennes - <sup>[8]</sup> L'objet de la déclaration décrit ci-dessus est conforme à la directive 2011/65/UE du Parlement européen et du Conseil du 8 juin 2011 relative à la limitation de l'utilisation de certaines substances dangereuses dans les équipements électriques et électroniques . <sup>[9]</sup> Normes - <sup>[10]</sup> La présente déclaration est valable à partir de la date de fabrication du produit. <sup>[10]</sup> La présente déclaration est valable pour le produit portant le numéro de série et la date de fabrication suivants.</p>
<p><b>IT</b> <sup>[1]</sup> Produttore - <sup>[2]</sup> Rappresentante autorizzato - <sup>[3]</sup> Tipo di prodotto - <sup>[4]</sup> Nomi dei modelli - <sup>[5]</sup> Tensione nominale, Frequenza nominali – <sup>[6]</sup> L'oggetto della dichiarazione di cui sopra è conforme alla pertinente normativa di armonizzazione dell'Unione <sup>[7]</sup> Direttive CE - <sup>[8]</sup> L'oggetto della dichiarazione di cui sopra è conforme alla direttiva 2011/65/UE del Parlamento europeo e del Consiglio dell'8 giugno 2011, sulla restrizione dell'uso di determinate sostanze pericolose nelle apparecchiature elettriche ed elettroniche <sup>[9]</sup> Standard - <sup>[10]</sup> Questa dichiarazione è valida dal prodotto costruito dopo la data. <sup>[10]</sup> Questa dichiarazione è valida per il prodotto con i seguenti numero di serie e data di produzione</p>
<p><b>ES</b> <sup>[1]</sup> Fabricante - <sup>[2]</sup> Representante autorizado - <sup>[3]</sup> Tipo de producto - <sup>[4]</sup> Modelos - <sup>[5]</sup> Tensión nominal, Frecuencia nominal - <sup>[6]</sup> El objeto de la declaración descrita anteriormente es conforme con la legislación de armonización pertinente de la Unión: <sup>[7]</sup> Directivas CE - <sup>[8]</sup> El objeto de la declaración descrito anteriormente es conforme a la Directiva 2011/65/UE del Parlamento Europeo y del Consejo, de 8 de junio de 2011, sobre restricciones a la utilización de determinadas sustancias peligrosas en aparatos eléctricos y electrónicos <sup>[9]</sup> Normas - <sup>[10]</sup> Esta declaración es válida para el producto fabricado después de la fecha. <sup>[10]</sup> Esta declaración es válida para el producto con el siguiente número de serie y fecha de manufactura.</p>
<p><b>PT</b> <sup>[1]</sup> Fabricante - <sup>[2]</sup> Representante Autorizado - <sup>[3]</sup> Tipo de Produto - <sup>[4]</sup> Nome(s) do Modelo - <sup>[5]</sup> Tensão Nominal, Frequência Nominal – <sup>[6]</sup> O objeto da declaração acima descrito está em conformidade com a legislação de harmonização da União aplicável: <sup>[7]</sup> Directivas da CE - <sup>[8]</sup> O objecto da declaração acima mencionada está em conformidade com a Directiva 2011/65/UE do Parlamento Europeu e do Conselho, de 8 de Junho de 2011, relativa à restrição do uso de determinadas substâncias perigosas em equipamentos eléctricos e electrónicos. <sup>[9]</sup> Normas - <sup>[10]</sup> Esta Declaração é válida para o produto fabricado após a data. <sup>[10]</sup> Esta Declaração é válida para o produto com o seguinte número de série e data de fabrico</p>
<p><b>NL</b> <sup>[1]</sup> Producent - <sup>[2]</sup> Gemachtigd vertegenwoordiger - <sup>[3]</sup> Producttype - <sup>[4]</sup> Modelnaam/namen - <sup>[5]</sup> Nominale spanning, nominale frequentie – <sup>[6]</sup> Het hierboven beschreven voorwerp is in overeenstemming met de desbetreffende harmonisatiewetgeving van de Unie: <sup>[7]</sup> EC-richtlijnen - <sup>[8]</sup> Het hierboven beschreven voorwerp is conform Richtlijn 2011/65/EU van het Europees Parlement en de Raad van 8 juni 2011 betreffende beperking van het gebruik van bepaalde gevaarlijke stoffen in elektrische en elektronische apparatuur: <sup>[9]</sup> Normen - <sup>[10]</sup> Deze verklaring is geldig voor de producten die zijn geproduceerd na deze datum. <sup>[10]</sup> Deze verklaring is geldig voor het product met het volgende serienummer en productiedatum.</p>
<p><b>PL</b> <sup>[1]</sup> Producent - <sup>[2]</sup> Autoryzowany Przedstawiciel - <sup>[3]</sup> Typ produktu - <sup>[4]</sup> Nazwa(y) modelu - <sup>[5]</sup> Napięcie znamionowe , częstotliwość znamionowa - <sup>[6]</sup> Wymieniony powyżej przedmiot niniejszej deklaracji jest zgodny z odpowiednimi wymaganiami unijnego prawodawstwa harmonizacyjnego: <sup>[7]</sup> dyrektywy KE - <sup>[8]</sup> Opisany powyżej przedmiot deklaracji jest zgodny z dyrektywą Parlamentu Europejskiego i Rady 2011/65/UE z dnia 8 czerwca 2011 r. w sprawie ograniczenia stosowania niektórych niebezpiecznych substancji w sprzęcie elektrycznym i elektronicznym: <sup>[9]</sup> Standardy - <sup>[10]</sup> Deklaracja ta jest ważna dla wyrobów wyprodukowanych po dacie. <sup>[10]</sup> Niniejsza deklaracja jest ważna dla produktu z następującym numerem seryjnym oraz datą produkcji.</p>
<p><b>CS</b> <sup>[1]</sup> Výrobce - <sup>[2]</sup> Autorizovaný zástupce - <sup>[3]</sup> Typ produktu - <sup>[4]</sup> Názvy modelů - <sup>[5]</sup> Jmenovité napětí, jmenovitý kmitočet – <sup>[6]</sup> Výše popsáný předmět prohlášení je ve shodě s příslušnými harmonizačními právními předpisy Unie: <sup>[7]</sup> Směrnice ES - <sup>[8]</sup> Výše popsáný předmět prohlášení je ve shodě se směrnicí Evropského parlamentu a Rady 2011/65/EU ze dne 8. června 2011 o omezení používání některých nebezpečných látek v elektrických a elektronických zařízeních: <sup>[9]</sup> Normy - <sup>[10]</sup> Toto prohlášení o shodě platí od data výroby produktu. <sup>[10]</sup> Toto prohlášení o shodě platí pro produkt s následujícím výrobním číslem a datem výroby.</p>

<p><b>DE</b> <sup>[1]</sup> Hersteller - <sup>[2]</sup> Bevollmächtigter Vertreter - <sup>[3]</sup> Produkttyp - <sup>[4]</sup> Modellbezeichnung(en) - <sup>[5]</sup> Nennspannung, Nennfrequenz – <sup>[6]</sup> Der oben beschriebene Gegenstand der Erklärung erfüllt die einschlägigen Harmonisierungsrechtsvorschriften der Union.: <sup>[7]</sup> EG-Richtlinien - <sup>[8]</sup> Der oben beschriebene Gegenstand der Erklärung erfüllt die Vorschriften der Richtlinie 2011/65/EU des Europäischen Parlaments und des Rates vom 8. Juni 2011 zur Beschränkung der Verwendung bestimmter gefährlicher Stoffe in Elektro- und Elektronikgeräten: <sup>[9]</sup> Normen - <sup>[10]</sup> Diese Erklärung gilt für die nach diesem Datum hergestellten Produkte. <sup>[10]</sup> Diese Erklärung gilt für das Produkt mit folgender Seriennummer und Herstellungsdatum</p>
<p><b>FR</b> <sup>[1]</sup> Fabricant - <sup>[2]</sup> Représentant agréé - <sup>[3]</sup> Type de produit - <sup>[4]</sup> Désignation(s) du modèle - <sup>[5]</sup> Tension nominale, Fréquence nominale – <sup>[6]</sup> L'objet de la déclaration décrit ci-dessus est conforme à la législation d'harmonisation de l'Union applicable : <sup>[7]</sup> Directives européennes - <sup>[8]</sup> L'objet de la déclaration décrit ci-dessus est conforme à la directive 2011/65/UE du Parlement européen et du Conseil du 8 juin 2011 relative à la limitation de l'utilisation de certaines substances dangereuses dans les équipements électriques et électroniques . <sup>[9]</sup> Normes - <sup>[10]</sup> La présente déclaration est valable à partir de la date de fabrication du produit. <sup>[10]</sup> La présente déclaration est valable pour le produit portant le numéro de série et la date de fabrication suivants.</p>
<p><b>IT</b> <sup>[1]</sup> Produttore - <sup>[2]</sup> Rappresentante autorizzato - <sup>[3]</sup> Tipo di prodotto - <sup>[4]</sup> Nomi dei modelli - <sup>[5]</sup> Tensione nominale, Frequenza nominali – <sup>[6]</sup> L'oggetto della dichiarazione di cui sopra è conforme alla pertinente normativa di armonizzazione dell'Unione <sup>[7]</sup> Direttive CE - <sup>[8]</sup> L'oggetto della dichiarazione di cui sopra è conforme alla direttiva 2011/65/UE del Parlamento europeo e del Consiglio dell'8 giugno 2011, sulla restrizione dell'uso di determinate sostanze pericolose nelle apparecchiature elettriche ed elettroniche <sup>[9]</sup> Standard - <sup>[10]</sup> Questa dichiarazione è valida dal prodotto costruito dopo la data. <sup>[10]</sup> Questa dichiarazione è valida per il prodotto con i seguenti numero di serie e data di produzione</p>
<p><b>ES</b> <sup>[1]</sup> Fabricante - <sup>[2]</sup> Representante autorizado - <sup>[3]</sup> Tipo de producto - <sup>[4]</sup> Modelos - <sup>[5]</sup> Tensión nominal, Frecuencia nominal - <sup>[6]</sup> El objeto de la declaración descrita anteriormente es conforme con la legislación de armonización pertinente de la Unión: <sup>[7]</sup> Directivas CE - <sup>[8]</sup> El objeto de la declaración descrito anteriormente es conforme a la Directiva 2011/65/UE del Parlamento Europeo y del Consejo, de 8 de junio de 2011, sobre restricciones a la utilización de determinadas sustancias peligrosas en aparatos eléctricos y electrónicos <sup>[9]</sup> Normas - <sup>[10]</sup> Esta declaración es válida para el producto fabricado después de la fecha. <sup>[10]</sup> Esta declaración es válida para el producto con el siguiente número de serie y fecha de manufactura.</p>
<p><b>PT</b> <sup>[1]</sup> Fabricante - <sup>[2]</sup> Representante Autorizado - <sup>[3]</sup> Tipo de Produto - <sup>[4]</sup> Nome(s) do Modelo - <sup>[5]</sup> Tensão Nominal, Frequência Nominal – <sup>[6]</sup> O objeto da declaração acima descrito está em conformidade com a legislação de harmonização da União aplicável: <sup>[7]</sup> Directivas da CE - <sup>[8]</sup> O objecto da declaração acima mencionada está em conformidade com a Directiva 2011/65/UE do Parlamento Europeu e do Conselho, de 8 de Junho de 2011, relativa à restrição do uso de determinadas substâncias perigosas em equipamentos eléctricos e electrónicos. <sup>[9]</sup> Normas - <sup>[10]</sup> Esta Declaração é válida para o produto fabricado após a data. <sup>[10]</sup> Esta Declaração é válida para o produto com o seguinte número de série e data de fabrico</p>
<p><b>NL</b> <sup>[1]</sup> Producent - <sup>[2]</sup> Gemachtigd vertegenwoordiger - <sup>[3]</sup> Producttype - <sup>[4]</sup> Modelnaam/namen - <sup>[5]</sup> Nominale spanning, nominale frequentie – <sup>[6]</sup> Het hierboven beschreven voorwerp is in overeenstemming met de desbetreffende harmonisatiewetgeving van de Unie: <sup>[7]</sup> EC-richtlijnen - <sup>[8]</sup> Het hierboven beschreven voorwerp is conform Richtlijn 2011/65/EU van het Europees Parlement en de Raad van 8 juni 2011 betreffende beperking van het gebruik van bepaalde gevaarlijke stoffen in elektrische en elektronische apparatuur: <sup>[9]</sup> Normen - <sup>[10]</sup> Deze verklaring is geldig voor de producten die zijn geproduceerd na deze datum. <sup>[10]</sup> Deze verklaring is geldig voor het product met het volgende serienummer en productiedatum.</p>
<p><b>PL</b> <sup>[1]</sup> Producent - <sup>[2]</sup> Autoryzowany Przedstawiciel - <sup>[3]</sup> Typ produktu - <sup>[4]</sup> Nazwa(y) modelu - <sup>[5]</sup> Napięcie znamionowe , częstotliwość znamionowa - <sup>[6]</sup> Wymieniony powyżej przedmiot niniejszej deklaracji jest zgodny z odpowiednimi wymaganiami unijnego prawodawstwa harmonizacyjnego: <sup>[7]</sup> dyrektywy KE - <sup>[8]</sup> Opisany powyżej przedmiot deklaracji jest zgodny z dyrektywą Parlamentu Europejskiego i Rady 2011/65/UE z dnia 8 czerwca 2011 r. w sprawie ograniczenia stosowania niektórych niebezpiecznych substancji w sprzęcie elektrycznym i elektronicznym: <sup>[9]</sup> Standardy - <sup>[10]</sup> Deklaracja ta jest ważna dla wyrobów wyprodukowanych po dacie. <sup>[10]</sup> Niniejsza deklaracja jest ważna dla produktu z następującym numerem seryjnym oraz datą produkcji.</p>
<p><b>CS</b> <sup>[1]</sup> Výrobce - <sup>[2]</sup> Autorizovaný zástupce - <sup>[3]</sup> Typ produktu - <sup>[4]</sup> Názvy modelů - <sup>[5]</sup> Jmenovité napětí, jmenovitý kmitočet – <sup>[6]</sup> Výše popsáný předmět prohlášení je ve shodě s příslušnými harmonizačními právními předpisy Unie: <sup>[7]</sup> Směrnice ES - <sup>[8]</sup> Výše popsáný předmět prohlášení je ve shodě se směrnicí Evropského parlamentu a Rady 2011/65/EU ze dne 8. června 2011 o omezení používání některých nebezpečných látek v elektrických a elektronických zařízeních: <sup>[9]</sup> Normy - <sup>[10]</sup> Toto prohlášení o shodě platí od data výroby produktu. <sup>[10]</sup> Toto prohlášení o shodě platí pro produkt s následujícím výrobním číslem a datem výroby.</p>

<p><b>EL)</b> <sup>[1]</sup> Κατασκευαστής - <sup>[2]</sup> Εξουσιοδοτημένος αντιπρόσωπος - <sup>[3]</sup> Είδος προϊόντος - <sup>[4]</sup> Ονομασία μοντέλου - <sup>[5]</sup> Ονομαστική τάση, Ονομαστική συχνότητα - <sup>[6]</sup> Ο στόχος της δήλωσης που περιγράφεται παραπάνω είναι σύμφωνος με τη σχετική ενωσιακή νομοθεσία εναρμόνισης: <sup>[7]</sup> Οδηγίες ΕΚ - <sup>[8]</sup> Το ανωτέρω περιγραφόμενο αντικείμενο της δήλωσης είναι σύμφωνο με την οδηγία 2011/65/ΕΕ του Ευρωπαϊκού Κοινοβουλίου και του Συμβουλίου, της 8ης Ιουνίου 2011, σχετικά με τον περιορισμό της χρήσης ορισμένων επικίνδυνων ουσιών σε ηλεκτρικό και ηλεκτρονικό εξοπλισμό: <sup>[9]</sup> Πρότυπα - <sup>[10]</sup> Η παρούσα δήλωση ισχύει για το κατασκευασμένο προϊόν μετά την ημερομηνία. <sup>[10]</sup> Η παρούσα δήλωση ισχύει για το προϊόν με τον ακόλουθο σειριακό αριθμό και την ημερομηνία κατασκευής</p>
<p><b>GA)</b> <sup>[1]</sup> Monaróir - <sup>[2]</sup> Ionadaí údaraithe - <sup>[3]</sup> Cineál Táirge - <sup>[4]</sup> Ainm (neacha) Samhail - <sup>[5]</sup> Rátáil Voltage , Minicíocht Rátáil - <sup>[6]</sup> Tá cuspóir an dearbhairte a bhfuil tuairisc air thuas i gcomhréir le reachtaíocht ábhartha an Aontais maidir le comhchuibhiú: <sup>[7]</sup> Treoracha CE - <sup>[8]</sup> Tá cuspóir an dearbhairte a bhfuil tuairisc air thuas i gcomhréir le Treoir 2011/65/AE ó Pharlaimint na hEorpa agus ón gComhairle an 8 Meitheamh 2011 maidir le srian ar shubstaintí guaiseacha áirithe a úsáid i dtrealamh leictreach agus leictreonach <sup>[9]</sup> Caighdeáin - <sup>[10]</sup> Tá an dearbhú bailí ón táirge a mhonaraítear i ndiaidh an dáta sin. <sup>[10]</sup> Tá an dearbhú bailí ar feadh an táirge foirgníochta an sraithuimhir leanas agus dáta monaraithe</p>
<p><b>HR)</b> <sup>[1]</sup> Proizvodáč - <sup>[2]</sup> Ovlašteni zastupnik - <sup>[3]</sup> Vrsta proizvoda - <sup>[4]</sup> Naziv(i) modela - <sup>[5]</sup> Nazivni napon, nazivna frekvencija - <sup>[6]</sup> Predmet navedene izjave u skladu je s mjerodavnim zakonodavstvom Unije o usklađivanju: <sup>[7]</sup> Direktive EZ-a - <sup>[8]</sup> Gore opisan predmet izjave u skladu je s Direktivom 2011/65/EU Europskog parlamenta i Vijeća od 8. lipnja 2011. o ograničavanju uporabe određenih opasnih tvari u električnoj i elektroničkoj opremi: <sup>[9]</sup> Norme - <sup>[10]</sup> Ova izjava vrijedi za proizvod proizveden nakon navedenog datuma. <sup>[10]</sup> Ova izjava vrijedi za proizvod sa sljedećim serijskim brojem i datumom proizvodnje</p>
<p><b>RO)</b> <sup>[1]</sup> Producător - <sup>[2]</sup> Reprezentant Autorizat - <sup>[3]</sup> Tipul Produsului - <sup>[4]</sup> Nume model(e) - <sup>[5]</sup> Tensiune nominală, Frecvența nominală - <sup>[6]</sup> Obiectul declarației descris mai sus este în conformitate cu legislația relevantă de armonizare a Uniunii: <sup>[7]</sup> Directive CE - <sup>[8]</sup> Obiectul declarației descris mai sus este conform Directivei 2011/65/UE a Parlamentului European și a Consiliului din 8 iunie 2011 privind restricțiile de utilizare a anumitor substanțe periculoase în echipamentele electrice și electronice: <sup>[9]</sup> Standarde - <sup>[10]</sup> Această declarație este valabilă pentru produsele fabricate după data curentă. <sup>[10]</sup> Această declarație este valabilă pentru produsul cu următorul număr de serie și următoarea dată de fabricație</p>
<p><b>HU)</b> <sup>[1]</sup> Gyártó - <sup>[2]</sup> Meghatalmazott képviselő - <sup>[3]</sup> Terméktípus - <sup>[4]</sup> Modell(ek) neve - <sup>[5]</sup> Névleges feszültség, névleges frekvencia - <sup>[6]</sup> A fent ismertetett nyilatkozat tárgya megfelel a vonatkozó uniós harmonizációs jogszabálynak: <sup>[7]</sup> EC-irányelvek - <sup>[8]</sup> E nyilatkozat fent leírt tárgya összhangban van az egyes veszélyes anyagok elektromos és elektronikus berendezésekben való alkalmazásának korlátozásáról szóló, 2011. június 8-i 2011/65/EU európai parlamenti és tanácsi irányelvvel: <sup>[9]</sup> Szabványok - <sup>[10]</sup> Jelen nyilatkozat a megadott dátum után gyártott termékekre érvényes. <sup>[10]</sup> Jelen nyilatkozat a következő sorozatszámú és gyártási dátumú termékre érvényes.</p>
<p><b>BG)</b> <sup>[1]</sup> Производител - <sup>[2]</sup> Оторизиран представител - <sup>[3]</sup> Тип продукт - <sup>[4]</sup> Име на модел - <sup>[5]</sup> Номинално напрежение, Номинална честота - <sup>[6]</sup> Предметът на декларацията, описан по-горе, отговаря на съответното законодателство на Съюза за хармонизация: <sup>[7]</sup> Директиви на ЕО - <sup>[8]</sup> Обектът на декларацията, който е описан по-горе, е в съответствие с Директива 2011/65/ЕС на Европейския парламент и на Съвета от 8 юни 2011 г. относно ограничението на употребата на определени опасни вещества в електрическото и електронното оборудване: <sup>[9]</sup> Стандарти - <sup>[10]</sup> Тази декларация е валидна за продуктите, произведени след датата. <sup>[10]</sup> Тази декларация е валидна за продукта със следния сериен номер и дата на производство.</p>
<p><b>ZH)</b> <sup>[1]</sup> 制造商 - <sup>[2]</sup> 授权代表 - <sup>[3]</sup> 产品类型 - <sup>[4]</sup> 型号 - <sup>[5]</sup> 额定电压、额定频率 - <sup>[6]</sup> 上述声明对象符合相关欧盟协调法规 <sup>[7]</sup> 欧盟指令 - <sup>[8]</sup> 上述声明对象符合欧洲议会和欧盟理事会2011年6月8日关于在电气和电子设备中限制使用某些有害物质的指令2011/65 / EU <sup>[9]</sup> 标准 - <sup>[10]</sup> 本声明自产品制造之日起生效。 <sup>[10]</sup> 本声明适用于具有下述序列号和制造日期的产品。</p>

## WARRANTY

Thermo Fisher Scientific warrants for 24 months (**excluding MD1/MD2 Magnetic Drive and P1/P2 Positive Displacement pumps which are warranted for 12 months**) from date of shipment the Thermo Scientific ThermoFlex chiller according to the following terms.

Any part of the chiller manufactured or supplied by Thermo Fisher Scientific and found in the reasonable judgment of Thermo Fisher to be defective in material or workmanship will be repaired at an authorized Thermo Fisher Repair Depot without charge for parts or labor. The chiller, including any defective part must be returned to an authorized Thermo Fisher Repair Depot within the warranty period. The expense of returning the chiller to the authorized Thermo Fisher Repair Depot for warranty service will be paid for by the buyer. Our responsibility in respect to warranty claims is limited to performing the required repairs or replacements, and no claim of breach of warranty shall be cause for cancellation or rescission of the contract of sales of any chiller. With respect to chillers that qualify for field service repairs, Thermo Fisher Scientific's responsibility is limited to the component parts necessary for the repair and the labor that is required on site to perform the repair. Any travel labor or mileage charges are the financial responsibility of the buyer.

The buyer shall be responsible for any evaluation or warranty service call (including labor charges) if no defects are found with the Thermo Scientific product.

This warranty does not cover any chiller that has been subject to misuse, neglect, or accident. This warranty does not apply to any damage to the chiller that is the result of improper installation or maintenance, or to any chiller that has been operated or maintained in any way contrary to the operating or maintenance instructions specified in this Instruction and Operation Manual. This warranty does not cover any chiller that has been altered or modified so as to change its intended use.

In addition, this warranty does not extend to repairs made by the use of parts, accessories, or fluids which are either incompatible with the chiller or adversely affect its operation, performance, or durability.

Thermo Fisher Scientific reserves the right to change or improve the design of any chiller without assuming any obligation to modify any chiller previously manufactured.

THE FOREGOING EXPRESS WARRANTY IS IN LIEU OF ALL OTHER WARRANTIES, EXPRESSED OR IMPLIED, INCLUDING BUT NOT LIMITED TO WARRANTIES OR MERCHANTABILITY AND FITNESS FOR A PARTICULAR PURPOSE.

OUR OBLIGATION UNDER THIS WARRANTY IS STRICTLY AND EXCLUSIVELY LIMITED TO THE REPAIR OR REPLACEMENT OF DEFECTIVE COMPONENT PARTS AND Thermo Fisher Scientific DOES NOT ASSUME OR AUTHORIZE ANYONE TO ASSUME FOR IT ANY OTHER OBLIGATION.

Thermo Fisher Scientific ASSUMES NO RESPONSIBILITY FOR INCIDENTAL, CONSEQUENTIAL, OR OTHER DAMAGES INCLUDING, BUT NOT LIMITED TO LOSS OR DAMAGE TO PROPERTY, LOSS OF PROFITS OR REVENUE, LOSS OF THE CHILLER, LOSS OF TIME, OR INCONVENIENCE.

This warranty applies to chillers sold by Thermo Fisher Scientific. (Refer to the warranty for chillers sold by the affiliated marketing company of Thermo Fisher Scientific for any additional terms.) This warranty and all matters arising pursuant to it shall be governed by the law of the State of New Hampshire, United States. All legal actions brought in relation hereto shall be filed in the appropriate state or federal courts in New Hampshire, unless waived by Thermo Fisher Scientific.







Thermo Fisher Scientific  
168 Third Avenue  
Waltham, Massachusetts 02451  
United States

[www.thermofisher.com](http://www.thermofisher.com)