

Thermo Scientific TSD Series

-40C Upright Lab Freezer

Operating and Maintenance Manual 7048838 Rev. 13

Visit us online to register your warranty
www.thermoscientific.com/labwarranty

Thermo
SCIENTIFIC

Important installer and user information:

A redundant temperature sensing device has been included in this ULT freezer. This device is a type “T” thermocouple. For convenient access, the thermocouple (Figure 1-3) terminates in an interconnect jack (Figure 1-5) behind the base front cover. (May be located differently in chests. See Section 1.) It is strongly recommended that this thermocouple be attached to a redundant 24 hour 7 day monitoring system with alarm capabilities.

Connecting the sensor to a monitoring and alarm system separate from the freezer provides the utmost in product safety, should the integral system fail. ▲

Packing List

| Part Number | Description | Quantity |
|-------------|------------------------|----------|
| 122005 | Key | 2 |
| 380520 | Neoprene Cap | 2 |
| 510016 | 1/4-20 x 5-1/2" Bolt | 2 |
| 195763 | Retaining Clip | 1 |
| 370563 | Remote Alarm Connector | 1 |

Models covered by this manual

| Catalog Number | Capacity (cu ft) | Voltage |
|----------------|------------------|------------|
| TSD40240A | 13/368.1 | 120/60 |
| TSD40240V | 13/368.1 | 230/50 |
| TSD40240D | 13/368.1 | 208-230/60 |
| TSD40320V | 17/489.9 | 230/50 |
| TSD40320D | 17/489.9 | 208-230/60 |
| TSD40320A | 17/489.9 | 120/60 |
| TSD40400A | 23/651.3 | 120/60 |
| TSD40400V | 23/651.3 | 230/50 |
| TSD40400D | 23/651.3 | 208-230/60 |

MANUAL NUMBER 7048838

| | | | | |
|----|---------------|----------|--|-----|
| 13 | 40634 | 11/03/17 | Updated exploded drawings | bpg |
| 12 | 41728 | 10/03/17 | Added door operation info pg 1-5 | bpg |
| 11 | 41370 | 8/11/17 | Updated BUS board information | bpg |
| 10 | 41159/40543 | 5/12/17 | Corrected D-volt rating, F-gas statement | bpg |
| 10 | 41347/41348 | 5/12/17 | Removed AS400 models, corrected operational temp range | bpg |
| 9 | 31601/FR-2833 | 9/19/16 | Updated door gasket in 902-200-1 on pgs 7-1 and 7-2 | ccs |



Important Read this instruction manual. Failure to read, understand and follow the instructions in this manual may result in damage to the unit, injury to operating personnel, and poor equipment performance. ▲

Caution All internal adjustments and maintenance must be performed by qualified service personnel. ▲

Material in this manual is for information purposes only. The contents and the product it describes are subject to change without notice. Thermo Fisher Scientific makes no representations or warranties with respect to this manual. In no event shall Thermo be held liable for any damages, direct or incidental, arising out of or related to the use of this manual.

The -40°C Freezers (see page i for specific list of models) described in this manual are high performance units which can be used for research and in situations that directly support medical applications. When these products are used to support a medical application, it is an accessory to a medical device and is therefore considered as a medical device in its own right by the regulatory body (e.g. FDA).

This product is intended for use:

- As cold storage in research use.
- As a medical device for diagnostic use (storage of samples not intended to be re-introduced to human body).

Intended Use

This product is intended for use as a General Purpose Laboratory Freezer for storing samples or inventory between -10 and -40°C.

This unit is not intended for use in an explosive environment, nor to be used for the storage of flammable inventory. This unit is not intended for use in a Class II medical application as defined by Title 21 of the Federal Code of Regulations.

Registration: This medical application is considered a Class I medical device by the FDA. This product is classified as product code – JRM, regulation number 862.2050 and is considered a Class 1 device, 510(K) exempt.

©2015 Thermo Fisher Scientific. All rights reserved.



Important operating and/or maintenance instructions. Read the accompanying text carefully.



Potential electrical hazards. Only qualified persons should perform procedures associated with this symbol.



Equipment being maintained or serviced must be turned off and locked off to prevent possible injury.



Extreme temperature hazards, hot or cold. Use special handling equipment or wear special, protective clothing.



WEEE Compliance: Thermo Fisher Scientific has contracted with companies for recycling/disposal in each EU Member State. For further information, send an email to weee.recycle@thermofisher.com.



- ✓ Always use the proper protective equipment (clothing, gloves, goggles, etc.)
- ✓ Always dissipate extreme cold or heat and wear protective clothing.
- ✓ Always follow good hygiene practices.
- ✓ Each individual is responsible for his or her own safety.

Do You Need Information or Assistance on Thermo Scientific Products?

If you do, please contact us 8:00 a.m. to 6:00 p.m. (Eastern Time) at:

1-740-373-4763

1-800-438-4851

1-877-213-8051

<http://www.thermofisher.com>

service.led.marietta@thermofisher.com

www.unitylabservices.com

Direct

Toll Free, U.S. and Canada

FAX

Internet Worldwide Web Home Page

Tech Support Email Address

Certified Service Web Page

Our **Sales Support** staff can provide information on pricing and give you quotations. We can take your order and provide delivery information on major equipment items or make arrangements to have your local sales representative contact you. Our products are listed on the Internet and we can be contacted through our Internet home page.

Our **Service Support** staff can supply technical information about proper setup, operation or troubleshooting of your equipment. We can fill your needs for spare or replacement parts or provide you with on-site service. We can also provide you with a quotation on our Extended Warranty for your Thermo Scientific products.

Whatever Thermo Scientific products you need or use, we will be happy to discuss your applications. If you are experiencing technical problems, working together, we will help you locate the problem and, chances are, correct it yourself...over the telephone without a service call.

When more extensive service is necessary, we will assist you with direct factory trained technicians or a qualified service organization for on-the-spot repair. If your service need is covered by the warranty, we will arrange for the unit to be repaired at our expense and to your satisfaction.

Regardless of your needs, our professional telephone technicians are available to assist you Monday through Friday from 8:00 a.m. to 6:00 p.m. Eastern Time. Please contact us by telephone or fax. If you wish to write, our mailing address is:

Thermo Fisher Scientific (Asheville) LLC
401 Millcreek Road, Box 649
Marietta, OH 45750

International customers, please contact your local Thermo Scientific distributor.

Table of Contents

| | | |
|------------------|---|------------|
| Section 1 | Installation and Start-Up | 1-1 |
| | Control Panel Keys, Displays & Indicators | 1-3 |
| | Keypad Operation | 1-4 |
| | Freezer Installation | 1-4 |
| | Choose the Location | 1-5 |
| | Door Operation | 1-5 |
| | Wall Bumper Installation | 1-5 |
| | Shelf Installation | 1-5 |
| | RS-232 Communications | 1-6 |
| | Remote Alarm Contacts | 1-7 |
| | Attach the Line Cord | 1-7 |
| | Connect Unit to Electrical Power | 1-8 |
| | Freezer Start-Up | 1-8 |
| | Set Operating Temperature | 1-9 |
| | Set High Temperature Alarm | 1-9 |
| | Set Low Temperature Alarm | 1-10 |
| | Run Mode | 1-10 |
| | | |
| Section 2 | Calibrate | 2-1 |
| | Calibrate the Control Probe | 2-1 |
| | | |
| Section 3 | Alarms | 3-1 |
| | Probe Failure Alarm | 3-2 |
| | | |
| Section 4 | Maintenance | 4-1 |
| | Clean the Air Filter | 4-1 |
| | Clean the Condenser | 4-2 |
| | Defrost the Chamber | 4-2 |
| | Prepare the Unit for Storage | 4-2 |
| | Clean the Door Gasket | 4-3 |
| | Clean the Vacuum Relief Port | 4-3 |
| | Replace the Battery(s) | 4-4 |
| | Check the Battery(s) | 4-5 |

| | | |
|-------------------|---|-------------|
| Section 5 | Preventive Maintenance | 4-6 |
| | Factory Installed Options | 5-1 |
| | Vent Stack, Solenoid and Injection Assembly | 5-2 |
| | Temperature Probe | 5-3 |
| | Connect the Probe/Solenoid Harness | 5-4 |
| | BUS Operation and Maintenance | 5-5 |
| | Configure the Optional Back-Up System | 5-7 |
| | Set the Optional Back-Up Setpoint | 5-8 |
| | Test BUS Operation | 5-8 |
| | Clean Vent Stack | 5-8 |
| | Disconnect the Fitting Assembly & Transfer Hose | 5-9 |
| | Chart Recorder | 5-9 |
| | Install the Chart Paper | 5-9 |
| | Change the Recorder Range | 5-10 |
| | Calibrate the Chart Recorder | 5-10 |
| | Five Inner Door Option | 5-10 |
| Section 6 | Specifications | 6-1 |
| Section 7 | Exploded Parts Drawings | 7-1 |
| Section 8 | Refrigeration Schematics | 8-1 |
| Section 9 | Electrical Schematics | 9-1 |
| Section 10 | Warranty Information | 10-1 |
| Section A | Appendix | A-1 |

Section 1 Installation and Start-Up

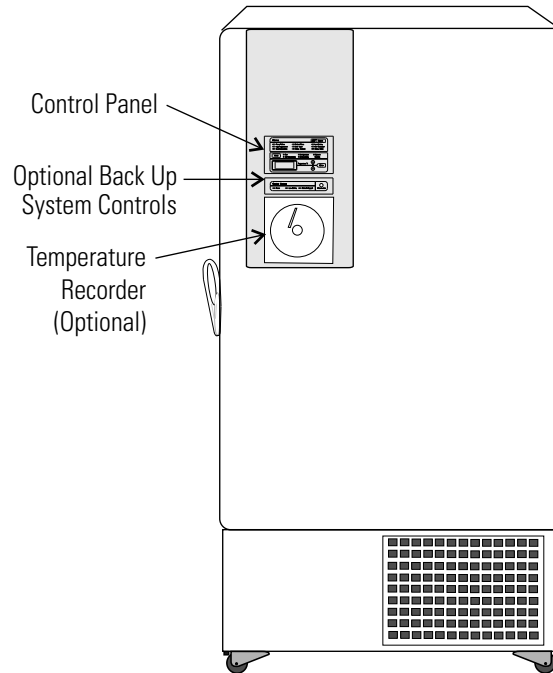

Figure 1-1. Front View

Figure 1-1

- Control Panel - keypad, displays and indicators.
- BUS (Optional Back Up System) panel.
- Optional temperature recorder - 7 day, one pen or Datalogger.

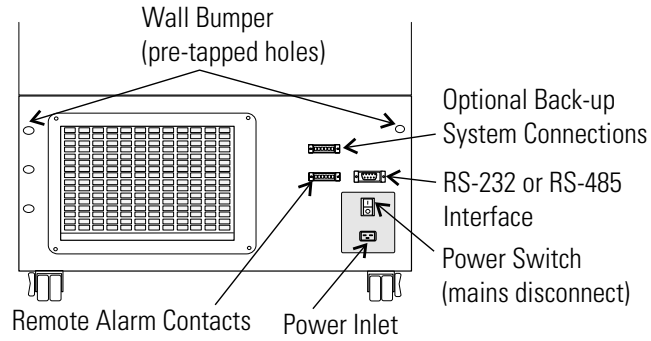

Figure 1-2. Rear View

Figure 1-2

- Remote alarm contacts.
- Power Inlet for power cord connection.
- Optional BUS connections for probe and solenoid.
- RS-232 or RS-485 Interface
- Power Switch (mains disconnect).

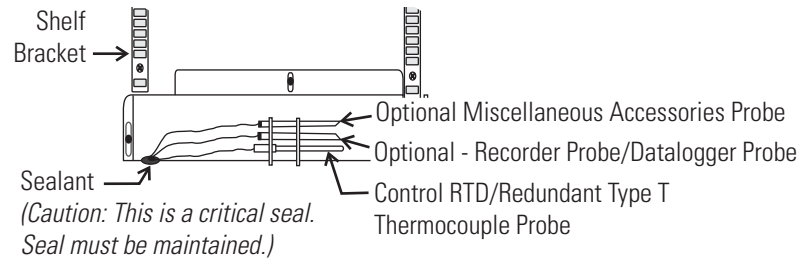

Figure 1-3. Chamber Probe

Figures 1-3 and 1-4

- Vacuum relief port: pressure equalization port.
- Probe cover: houses control, optional recorder, datalogger or miscellaneous accessory probes.

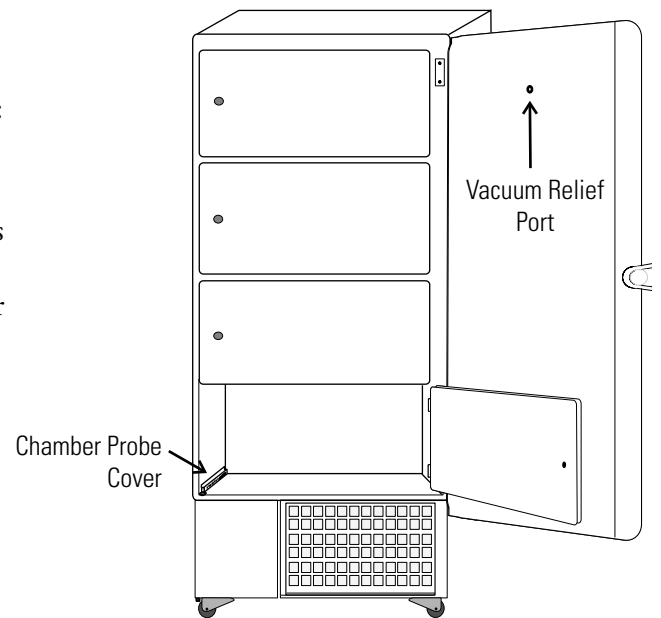

Figure 1-4. Vacuum Relief Port & Probe Cover Locations

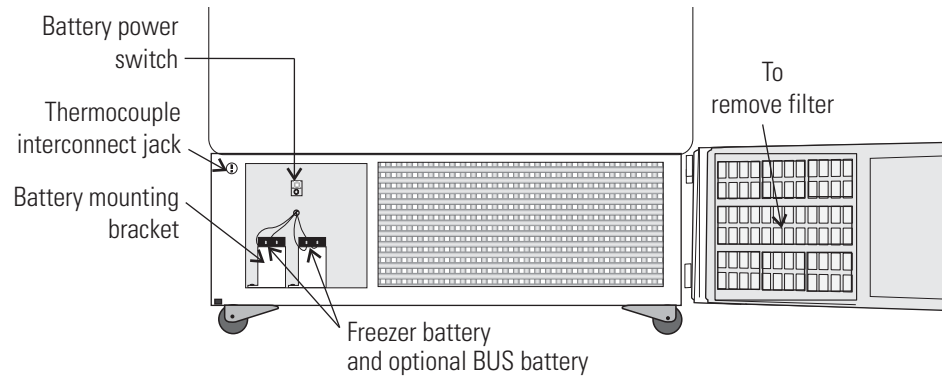

Figure 1-5. Battery(s) Location and Switch

Figure 1-5

- Battery mounting bracket(s)
- Battery power switch (freezer and BUS)
- Freezer battery
- Optional BUS battery
- Freezer filter location

Control Panel Keys, Displays & Indicators

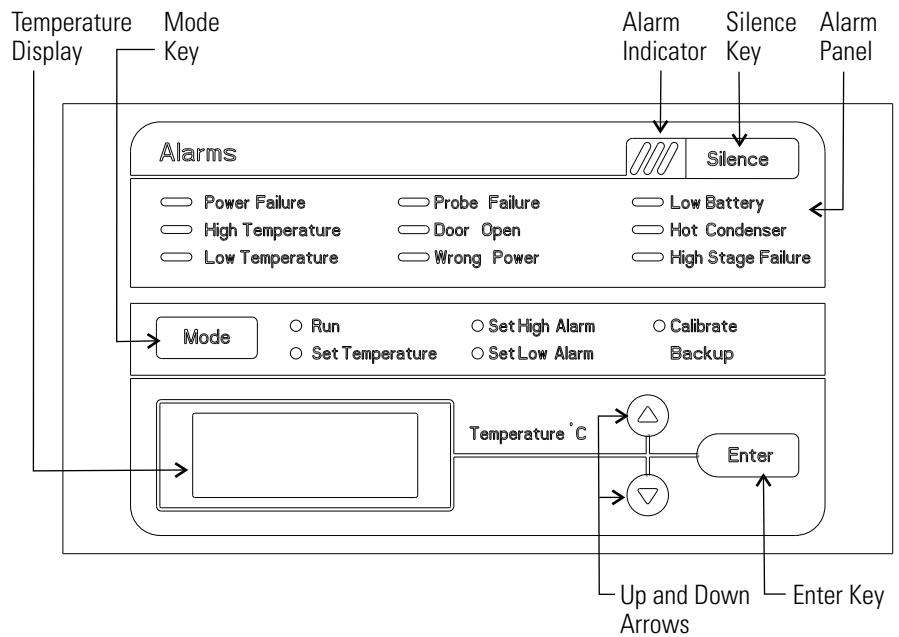

Figure 1-6. Control Panel

Control Panel (continued)

1. **Temperature Display** - Displays temperature in degrees Celsius.
2. **Mode Select Switch** - Used to select Run, Set Temperature, Set High Alarm, Set Low Alarm, Calibrate, Backup.
3. **Alarm Indicator** - Light pulses on/off during an alarm condition of the cabinet.
4. **Silence** - Silences the audible alarm. See Section 4 for alarm ringback times.
5. **Alarm Panel** - indicates the current alarm condition.
6. **Up and Down Arrows** - Increase or decrease values, toggle between choices.
7. **Enter** - Stores the changed value into memory.

Keypad Operation

The Thermo Scientific TSD Series freezer has five basic modes to allow freezer setup and operation. Press the Mode key to scroll through mode selections.

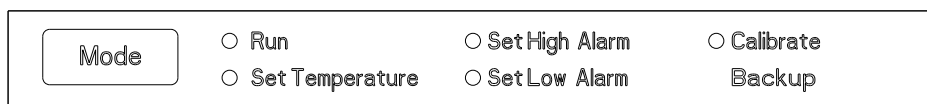

Figure 1-7. Basic Modes

Freezer Installation

Caution If tipped more than 45°, allow the unit to sit upright for 24 hours before start up. ▲

To remove the freezer from the pallet, use the 1/2" wrench to remove all bolts securing the shipping bracket to the pallet. Remove the shipping bracket.

Remove the ramp boards from the pallet and place the slotted ends over the ramp brackets on the pallet. The support blocks on the ramps will be facing down. Before moving the freezer, make sure the casters are unlocked and moving freely. Align the caster with the ramp boards. Use adequate personnel to roll the freezer off the pallet.

The freezer can be easily pushed to the desired approved location. If necessary, the doors and lower front panel may be opened to move the unit through tight openings. When the freezer is in position, set the front caster brakes.

Freezer Installation (continued)

Caution The freezer must not be moved with product load inside. ▲

Caution For proper ventilation and airflow, a minimum clearance of 5” at the rear and top and a clearance of 8” on the side of the freezer is required. Allow adequate space in the front of the freezer for door opening. ▲

Choose the Location

Locate the freezer on a firm, level surface in an area with an ambient temperature between 18°C and 28°C. Provide ample room to reach the mains disconnect switch (power switch) located on the rear of the freezer.

Door Operation

Upright freezer models are equipped with an advanced assembly specifically designed for ultra-low temperature freezers.

Features include:

- One-hand operation
- A front-accessible lock
- Hasps for a standard padlock to provide additional security. Length of the shackle must be between ¾ inch (1.9 cm) and 1½ inch (3.8 cm).
- Durable construction for reliable operation and safe product storage.

Wall Bumper Installation

The parts bag, located inside the cabinet, contains the following parts.

| Qty | Stock # | Description | Purpose |
|-----|---------|----------------------|---------------|
| 2 | 510016 | 1/4-20 x 5-1/2” Bolt | Wall Bumper |
| 2 | 380520 | Neoprene Cap | Cap Protector |

Install the bolts into the pre-tapped holes on the back of the compressor section. Install a neoprene cap on each bolt. Refer to Figure 1-2 for the locations of the pre-tapped holes.

Shelf Installation

Install the shelf clips into the shelf pilasters (front and back) at the desired shelf level. Install the shelves in the cabinet onto the clips.

Note Maximum shelf load is 100 lbs (45.4 kg) per shelf. ▲

Remote Alarm Contacts

See Figure 1-2 for the location of the remote alarm contacts. The remote alarm connector is located in the parts bag provided with the manual. It must be installed if connecting the freezer to an alarm system. After installing the wiring from the alarm system to the connector, install the connector to the freezer microboard and secure with the two screws provided. The remote alarm provides a NO (normally open) output, a NC (normally closed) output and COM (common). The contacts will trip on a power outage, and high or low temperature alarm. They will also trip on control probe or microboard failure. Figure 1-9 shows the remote contacts in alarm state.

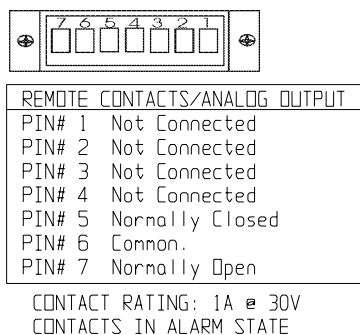

IMPORTANT USER INFORMATION

CAUTION! Stored product should be protected by a redundant 24 hour/day monitoring system with alarm capability. An interconnect jack and thermocouple are installed for centralized monitoring, should on-board system fail.

Figure 1-9. Remote Alarms Contacts

Attach the Line Cord

Insert the power line cord into the power inlet module. Place the retaining bracket (P/N 195763) over the connector. Tighten retaining screws to secure.

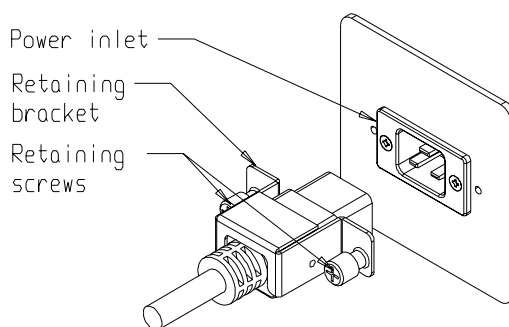

Figure 1-10. Line Cord

Connect Unit to Electrical Power

Note See the serial tag on the side of the unit for electrical specifications or refer to the electrical schematics in this manual. ▲

The freezer should be operated on a dedicated grounded service. Check the voltage rating on the serial tag of the unit and compare it with the outlet voltage. Then, with the power switch turned off, plug the line cord into the wall outlet.

First, turn on the freezer power switch. Then open the lower front door by grasping the bottom left corner. Locate the battery switch (Figure 1-5) and turn it to Standby mode (Ⓢ). During initial freezer start-up, the system battery may require charging and the Low Battery indicator may illuminate.

Caution Ensure the battery switch is turned to Standby mode (Ⓢ). The rechargeable batteries require 36 hours to charge at initial start-up. A “Low Battery” alarm may occur until the batteries are fully charged. Should a power failure occur during the initial start-up period, the electronics will have limited operation. ▲

Freezer Start-Up

With the freezer properly installed and connected to power, system setpoints can be entered. The following setpoints can be entered in Settings mode: Control temperature, high temperature alarm setpoint, low temperature alarm setpoint, and (optional) BUS setpoint. Default settings are shown in the table below.

| | |
|-------------------------------|-------|
| Control Set Point | -40°C |
| High Temperature Alarm | -30°C |
| Low Temperature Alarm | -50°C |
| Optional BUS Set Point | -30°C |

Note If the setpoint is changed and the low temperature and high temperature alarms are set 10° from the setpoint, the alarm setpoints will be adjusted automatically to maintain a distance of at least 10° from setpoint. ▲

Set Operating Temperature

The Thermo Scientific TSD Series -40°C freezers have an operating temperature range of -10°C to -40°C. The freezer is shipped from the factory with a temperature setpoint of -40°C. To change the operating temperature setpoint:

1. Press the Mode key until the Set Temperature indicator lights.
2. Press the up/down arrow key until the desired temperature set point is displayed.
3. Press Enter to save the setpoint.
4. Press the Mode key until the Run indicator lights for Run mode

If no keys are pressed, the freezer will automatically return to RUN mode after 5 minutes.

Note At -20°C operation, the probe may need to be calibrated to ensure cabinet temperatures are within the required range. Refer to Calibration section for the procedure. ▲

Set High Temperature Alarm

The high temperature alarm activates an audible/visual warning when the freezer chamber temperature has reached or exceeded the high temperature alarm setpoint.

To set the high temperature alarm setpoint:

1. Press the Mode key until the Set High Alarm indicator lights.
2. Press the up or down arrow key until the desired high temperature alarm setpoint is displayed.
3. Press Enter to save the setting.
4. Press the Mode key until the Run indicator lights for Run mode.

If no control keys are pressed, the freezer will automatically return to RUN mode after 5 minutes.

Note The high alarm set point must be set at least 5°C from the control set point. ▲

Caution At initial start-up, the high temperature alarm is disabled until the cabinet reaches setpoint, or 12 hours elapse. ▲

Section 1

Installation and Start-Up

Set Low Temperature Alarm

The low temperature alarm activates an audible/visual warning when the freezer chamber temperature reaches or decreases below the low temperature alarm setpoint.

To set the low temperature alarm set point:

1. Press the Mode key until the Set Low Alarm indicator lights.
2. Press the up or down arrow key until the desired low temperature alarm setpoint is displayed.
3. Press Enter to save the setting.
4. Press the Mode key until the Run indicator lights for Run mode.

If no control keys are pressed, the freezer will automatically return to RUN mode after 5 minutes.

Note The low alarm set point must be set at least 5°C from the control set point. ▲

Run Mode

Run mode is the default mode for the freezer. Run mode displays the cabinet temperature on the temperature display under normal operating conditions.

This information is scrolled by pressing the up or down arrow keys. The display will return to the operating temperature in 10 seconds if no keys are pressed.

Section 2 Calibrate

After the freezer has stabilized, the control probe may require calibration. Calibration frequency is dependent on use, ambient conditions and accuracy required. A good laboratory practice would require at least an annual calibration check. On new installations, all parameters should be checked after the stabilization period.

Note At -20°C operation, the probe may need to be calibrated to ensure cabinet temperatures are within the required range. Refer to the Calibration section for the procedure. ▲

Caution Before making any calibration or adjustments to the unit, it is imperative that all reference instruments be properly calibrated. ▲

Calibrate the Control Probe

Plug a type T thermocouple reader into the receptacle inside the lower door (Figure 1-5). Compare the control temperature setpoint to the temperature of the measuring device.

1. Press the Mode key until the Calibrate indicator lights.
2. Press up/down arrow to match the display to calibrated instrument.
3. Press Enter to store calibration.
4. Press the Mode key to return to Run mode.

Probe Calibration for -20C Operation

Note If the peak variation is within $\pm 5^{\circ}\text{C}$ of set value, then no calibration is required. ▲

1. Set temperature to -20C.
2. Calibrate probe to -4°C (-2.5 for 13 ft units) per above procedure.
3. Allow unit to stabilize to -20°C per temperature stabilization period below.
4. Check peak variation after unit has achieved steady state operation. Probe may need to be calibrated a second time to achieve the required range.

Calibrate the Control Probe (continued)

Temperature Stabilization Periods

Start-up - Allow 12 hours for the temperature in the cabinet to stabilize before proceeding.

Already Operating - Allow at least 2 hours after the display reaches set point for temperature to stabilize before proceeding.

Caution During calibration, the temperature display is disabled. ▲

If no keys are pressed for approximately five minutes while in Calibration mode, the system will return to Run mode.

Section 3 Alarms

Thermo Scientific TSD Series freezer alarms are displayed on the freezer control panel. When an alarm is active, the indicator next to the alarm description will light and there will be an audible alarm. Press the Silence key to disable the audible alarm for the ringback period. The visual alarm will continue until the freezer returns to a normal condition. The alarms are momentary alarms only. When an alarm condition occurs and then returns to normal, the freezer automatically clears the alarm condition.

| Description | Delay | Ringback | Relay |
|----------------------------|--------|----------|-------|
| Power Failure | 1 min. | 15 min. | Yes |
| High Temperature Alarm | 1 min. | 15 min. | Yes |
| Low Temperature Alarm | 1 min. | 15 min. | Yes |
| Probe Failure | 1 min. | 15 min. | No |
| Door Open | 1 min. | 15 min. | No |
| Wrong Power | 0 min. | none | Yes |
| Low Battery* | 1 min. | 8 hours | No |
| Low BUS Battery (optional) | 1 min. | 15 min. | No |
| Hot Condenser | 1 min. | none | No |
| MicroBoard Failure | 0 min. | 15 min. | Yes |

All alarm delays and ringback times are ± 30 seconds.

**The automatic battery test runs immediately on initial start-up, then every 8 hours thereafter.*

Probe Failure Alarm

The microprocessor in TSD Series freezers continually scans all probes, including the control probe, heat exchanger probe and condenser probe, to ensure that they are operating properly. Should an error be detected, the "Probe Failure" alarm occurs as described above. If an error is detected with the control probe, the high and low stage compressors run continuously. As a result, the cabinet temperature decreases until it reaches the lowest temperature the refrigeration system can maintain. If an error is detected with the heat exchanger probe, the freezer cycles properly at its temperature setpoint using a 5 minute step-start between the high and low stage compressors. If an error is detected with the condenser probe, there is no impact on the performance of the freezer; however, the hot condenser alarm may also occur. Contact the Technical Services department or your local distributor.

Section 3

Alarms

| Error | Notes |
|-------|--|
| Er00 | <p>Name: Improper model selected.</p> <p>Description: Indicates that DIP SW3 has not selected a proper model or can't be accessed properly.</p> <p>Response: Display shows "Er00" and will not start-up until a proper model is selected. Contact Technical Services.</p> |
| ErA1 | <p>This error condition will prevent peripherals (fans, compressors, etc.) from powering up with the incorrect voltage.</p> <p>Name: Voltage/Frequency failure</p> |
| ErC1 | <p>Description: Indicates the measured RMS line voltage did not agree with the logic level sensed by the micros provided by the installed high voltage PCB; or the measured RMS voltage is not within a tolerable range (<180VAC < 270 for 230VAC unit / < 85VAC < 160 for 115VAC unit); or the frequency measured over 10 cycles was not within a tolerable range (55 Hz < Freq < 70 Hz for 60 Hz units / 40 Hz < Freq < 55 Hz for 50 Hz units)</p> |
| Erd1 | <p>Response: This condition is checked at power on reset and if it is active, the unit will NOT power up. The unit will indefinitely display "Er_1" in the display and continue to monitor the frequency and voltage. Furthermore, the audible alarm will sound. Other startup error messages may be displayed prior to this message; however, the system will stop the startup sequence for this condition.</p> |
| ErE1 | <p>ErA1 .. No pulses (zero crossings) detected to determine frequency (50 / 60 Hz)</p> |
| ErF1 | <p>ErC1 .. Frequency detected is below 50 Hz</p> <p>Erd1 .. Frequency detected is above 60 Hz (Possible noise spikes on supply voltage)</p> |
| Erg1 | <p>ErE1 .. Unit is 230V and the voltage detected is below the low limit (180VRMS)</p> <p>ErF1 .. Unit is 230V and the voltage detected is above the high limit (260VRMS)</p> |
| ErH1 | <p>Erg1 .. Unit is 115V and the voltage detected is below the low limit (85VRMS)</p> <p>ErH1 .. Unit is 115V and the voltage detected is above the high limit (160VRMS)</p> |
| Er02 | <p>Name: Control (Cabinet) Sensor Failure</p> <p>Description: This condition indicates that the control sensor has failed to produce a valid reading for ≥ 12 consecutive reads (~60 seconds).</p> <p>Response: The unit will stage both compressors on (if necessary) and the unit will attempt to head to bottom out. If the sensor recovers, the system will begin to operate normally and respond to the temperature feedback. The remote alarm contacts will become active. 'Er02' will be added to the main display queue and the last valid cabinet temperature value will not be displayed.</p> |

| Error (cont.) | Notes |
|----------------------------------|--|
| Er05 | <p>Name: Display Firmware Integrity Failure</p> <p>Description: The display firmware has failed to pass its CRC CCITT checksum integrity test.</p> <p>Response: The display performs this check at startup and the display board will fail to startup without any error indication if it does not pass this at power on.</p> |
| Er06 | <p>Name: Micro Firmware Integrity Failure</p> <p>Description: The micro firmware has failed to pass its CRC CCITT checksum integrity test.</p> <p>Response: This is checked at power on reset and the "Er06" will be displayed for ~10 seconds at startup if this condition exists.</p> |
| Er07 | <p>Name: Micro Fail - CS5521 SPI Failure / UISR Failure</p> <p>Description: This condition indicates a micro board failure due to either the SPI bus is unable to communicate with the ADC device or a UISR event caused the microcontroller to be in an unstable state.</p> <p>Response: The unit will try to recover from this fault three times by a hardware reset of the micro board. In the event that the system couldn't rectify the issue, the following sequence of events will occur:</p> <ol style="list-style-type: none"> 1. Remote alarm contacts will become active. 2. Buzzer will annunciate audibly and will have a ringback of 15 minutes. 3. "Seven segment" display will show "Er07". 4. The compressor will activate. 5. The system will go to bottom out temperatures. |
| Er09 | <p>Name: Stuck Button</p> <p>Description: This condition indicates that the display board has a stuck button.</p> <p>Response: The Er09 will show on the display periodically.</p> |
| Er11 | <p>Name: Condenser Probe Sensor Failure</p> <p>Description: This condition indicates that the condenser probe sensor has failed to produce a valid reading for ≥ 12 consecutive reads (~60 seconds).</p> <p>Response: The display shows "Er11".</p> |
| dErr | <p>This is a general display error in which value being displayed can not be represented within characters provided.</p> |
| (Four dashes) ---- in display | <p>Name: Lost Communication</p> <p>Description: Communication between the micro board and the display board has been lost. Under this condition, the visual alarm flashes along with dashes in the temperature display (----). Contact Technical Services.</p> |

Section 4 Maintenance

Warning Avoid the excessive use of water around the control area due to the risk of electrical shock. Damage to the controls may also result. ▲

Wipe down the freezer exterior using soap and water and a general-use laboratory disinfectant. Rinse thoroughly with clean water and dry with a soft cloth.

Clean the Air Filter

The procedure for cleaning the air filter (minimum of four times a year) follows.

1. Open the front lower door by grasping the bottom left corner.
2. Locate the filter material behind the grille on the door. See Figure 4-1. Grasp the middle of the filter material and gently pull out to remove.
3. Wash the filter material using water and a mild detergent.
4. Dry by pressing between two towels.
5. Install the filter back into the grille and close the lower door.

Depending upon environmental conditions, the filter may need to be cleaned or replaced more frequently. If the filter becomes torn or excessively dirty, a replacement can be purchased from Thermo. See the exploded parts list for the filter part number. A filter kit (set of 5) is also available.

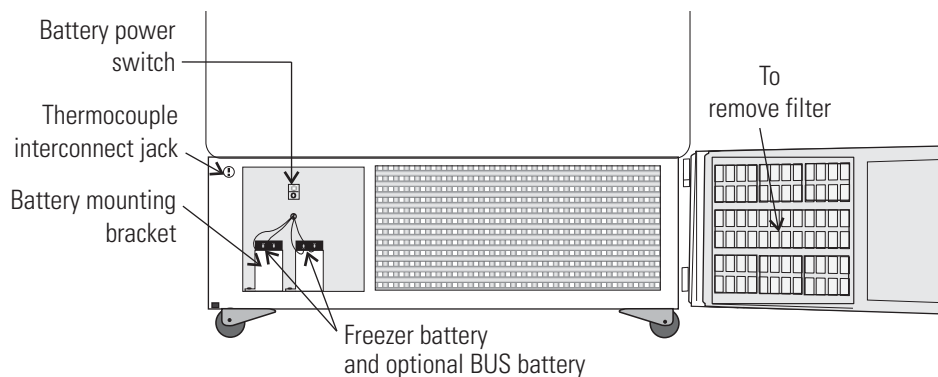

Figure 4-1. Component Locations

Clean the Condenser

The procedure for cleaning the condenser (minimum yearly) follows.

1. Open the front lower door by grasping the bottom left corner. See Figure 1-5.
2. Using a vacuum cleaner, exercising care to not damage the condenser fins, clean the condenser.

Depending upon environmental conditions, the condenser may need to be cleaned more frequently.

Caution Do not use liquids that are corrosive to stainless steel or the brazing material (copper or nickel). ▲

Defrost the Chamber

The procedure for defrosting the chamber follows.

1. Remove all product and place it in another freezer.
2. Turn the unit off and disconnect it from the power source.
3. Turn off the battery switch (O). See Figure 4-1.
4. Open all of the doors and place towels on the chamber floor.
5. Allow the frost to melt and become loose.
6. Remove the frost with a soft cloth.
7. After defrosting is complete, clean the interior with a non-chloride detergent. Rinse thoroughly with clean water and dry with a soft cloth.
8. Plug unit in and turn power switch on.
9. Turn the battery power switch to Standby mode (Ⓞ).
10. Allow the freezer to operate empty overnight before reloading the product.

Prepare the Unit for Storage

Defrost the unit as described previously. This prepares the unit for storage. Turn off the battery power switch (O). Turn off the freezer power switch. Disconnect power to the battery(s) and to the freezer.

Caution If the unit has been in service, turn it off and disconnect the power cord connector before proceeding with any maintenance. ▲

Clean the Door Gasket

The procedure for cleaning the door gasket (minimum monthly) follows.

Using a soft cloth, remove any frost build-up from the gasket and door(s). The door gasket may need to be cleaned more frequently if dirt or excessive frost build-up prevents the door from closing properly.

Clean the Vacuum Relief Port

The exterior door gasket provides an excellent seal that protects product, provides an energy efficient thermal barrier to keep cold air in and room temperature air out and reduces frost build up on the inner doors.

Because the door gasket seals so well, a vacuum can be created after a door opening. Warm air enters the cabinet, cools and contracts, creating a vacuum that pulls the door in tightly against the seal.

To equalize the pressure inside the cabinet after a door opening requires 1.5-3.0 cu.ft. of ambient air to be drawn into the cabinet. The amount of air required to equalize the pressure varies depending on the cabinet size, cabinet temperature, duration of door opening, inventory volume and the temperature/humidity of the ambient air. The unit is designed with a 'vacuum relief port' to allow the pressure to be equalized.

The time required to draw 1.5-3.0 cu.ft. of air into the cabinet depends on two factors,

- a) size and number of paths available for the air to enter the cabinet,
- b) pressure difference between the internal cabinet and the ambient room.

Cabinets with the vacuum relief port operating normally, (i.e. vacuum relief port is not iced over) will require a minimum of 30 seconds up to a maximum of 120 seconds for the cabinet to equalize. This is also a good indication that the exterior door is well sealed.

The vacuum relief port requires routine maintenance. It will ice over unless preventive measures are taken. If the vacuum relief port becomes iced over, the freezer will take several hours to equalize pressure.

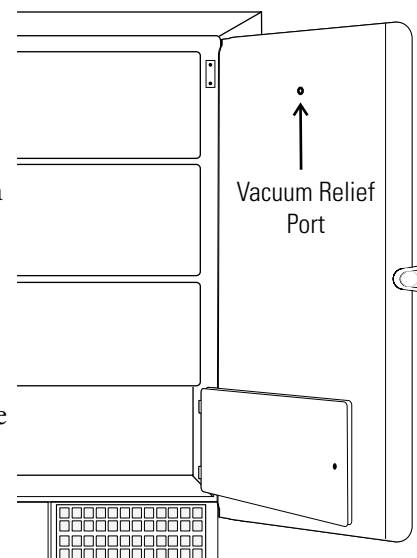

Figure 4-2. Port Location

Clean the Vacuum Relief Port (cont.)

Caution Do not leave the freezer unattended with the door unlatched. The vacuum could release, resulting in a door opening and possible product loss. ▲

Observe the inner side of port with each door opening for frost and ice build-up. Remove any frost with a soft dry cloth. If the tube should become clogged with ice, it must be cleaned. **Make sure during cleaning that the vacuum relief tube is completely free of ice to prevent rapid ice formation.**

Other factors that can affect the performance of the vacuum relief port include: high ambient temperature, high humidity conditions and frequent door openings. Maintenance should be performed weekly, or as needed.

Caution Failure to maintain the vacuum relief port may result in excessive ice build-up inside the tube, clogging the port, resulting in an inability to open the door. The vacuum relief port may need to be cleaned more often with frequent door openings and high humidity environments. ▲

Replace Battery(s)

1. To gain access to the battery, open the lower door by grasping the bottom left corner. The battery is rectangular in shape, located on the front left corner of the compressor compartment and is secured in place by a mounting bracket.
2. Directly above the battery(s) is the battery power switch. Turn the battery power switch to the Off position (O).
3. Disconnect the battery connections.
4. Remove the old battery and install the new battery.
5. Reconnect the battery (red to positive and black to negative).
7. Turn the battery power switch to Standby mode (⏻).
8. Close lower panel door.

Caution The % of charge can vary depending on the age, usage and condition of the battery. For a consistent and dependable charge, replace the battery every 2 years. Replacement batteries must be rechargeable and are available from Thermo. Refer to the parts list for stock number and description of the replacement batteries. Dispose of used batteries in a safe manner and in accordance with good environmental practices. ▲

Check Battery(s)

1. To gain access to the battery, open the lower door by grasping the bottom left corner. The battery is rectangular in shape, located on the front left corner of the compressor compartment and is secured in place by a mounting bracket.
2. Directly above the battery(s) is the battery power switch. Turn the battery power switch to the off position (O).
3. Cut the tie wrap securing the battery to the mounting bracket. Lift the battery out of the bracket.
4. Disconnect the red and black wires from the battery.
5. Use a voltmeter set to DC volts. Matching the wire colors, connect the meter to the battery.
6. If the voltage reads less than 10.8 volts, replace the battery. If above 10.8, re-install as previously.
7. Turn the battery power switch to Standby mode (Ⓢ).
8. Close lower panel door.

PREVENTIVE MAINTENANCE

Freezers

Your equipment has been thoroughly tested and calibrated before shipment. Regular preventive maintenance is important to keep your unit functioning properly. The operator should perform routine cleaning and maintenance on a regular basis. For maximum performance and efficiency, it is recommended that the unit be checked and calibrated periodically by a qualified service technician.

The following is a condensed list of preventive maintenance requirements. See the specified section of the instruction manual for further details.

We have qualified service technicians, using NIST traceable instruments, available in many areas. For more information on Preventive Maintenance or Extended Warranties, please contact us at the number below.

Cleaning and calibration adjustment intervals are dependent upon use, environmental conditions and accuracy required.

Tips:

- Fill an upright by starting at the bottom near the probe and add racks to one shelf at a time. Allow freezer to recover to set point between shelves.
- Fill a chest by starting at the left side near the probe. Filling with room temperature racks will result in a long pull-down time.
- Fill unit with frozen product to help overall performance; frozen water jugs, for example.
- Always make certain the vacuum relief port is free of frost and ice, to allow for timely re-entry into the freezer after a door opening.

• 401 Millcreek Road, Box 649 • Marietta, Ohio 45750 USA • 740-373-4763

• USA and Canada 800-438-4851 • Telefax: 740-373-4189 • email: service.led.marietta@thermo.com/forma

Preventive Maintenance for TSD Series Freezers

| Refer to Manual Section | Action | Monthly | Yearly | Every 2 Years |
|---|--|---------|---|------------------|
| -- | Verify ambient temperature, <90°F | ✓ | | |
| -- | * Adjust door handle for firm latching, as needed | ✓ | | |
| Figure 1-4 for probe location 4.5, 4.6 | Check and clean probe cover, gaskets, hinges, and vacuum relief port of ice and snow | ✓ | More frequent cleaning may be required, depending on use and environmental conditions | |
| 4.2 | Check air filter. Clean or replace as needed | | ✓ 4X | |
| 1.5.f, 4.7 | Check alarm back-up battery | ✓ | | ** Replace |
| -- | Check condenser fan motor for unusual motor noise or vibration | | ✓ | |
| 2 | * Verify and document calibration, at the minimum, annually | | ✓ | |
| 4.3 | * Clean condenser compartment and wipe off condenser | | ✓ | |

* Qualified service technicians only

** Dispose of properly, according to all state and federal regulations

To minimize ice build-up inside of freezer:

Locate the freezer away from drafts or heating/cooling vents

Keep the number of door openings to a minimum

Minimize the length of time door is open

Make sure door latches securely after opening

Section 5 Factory Installed Options

Described below are the factory installed options which are available, or may be already installed, on your unit.

Back-Up System (BUS) - P/N 1960445, 1960447

Warning Before installation of BUS components, make sure the power to the freezer is disconnected, the battery switch is turned off (O) and the freezer has warmed to ambient temperature. ▲

The built-in BUS (back up system) will keep the freezer chamber temperature below the critical level in the event of a power or equipment failure. If power to the freezer fails, or temperature increases to the back up alarm set point, the BUS injects liquefied gas into the chamber to keep the chamber temperature within the specified range.

The BUS operates on an internal 12-volt, rechargeable battery which is kept charged during normal operation by the integral battery charger.

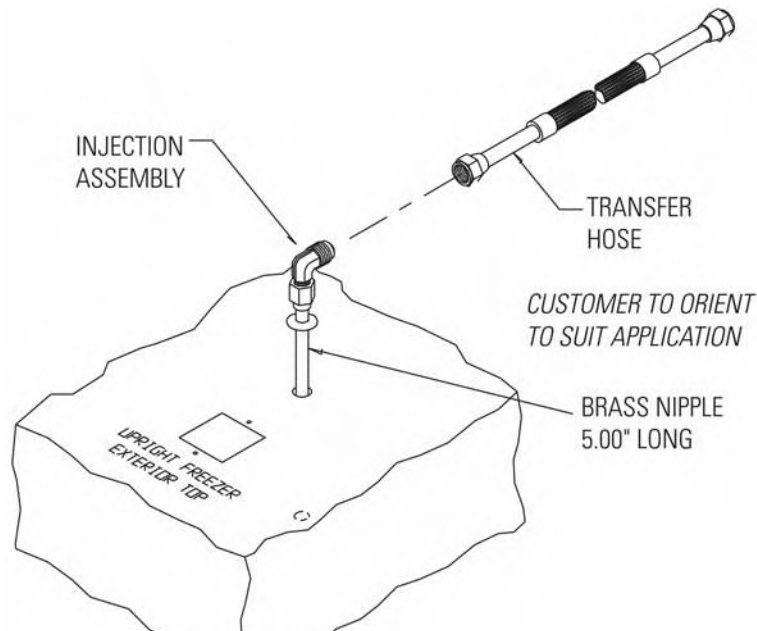

Figure 5-1. Injection Assembly

Vent Stack, Solenoid and Injection Assembly

1. Install the injection assembly (Figure 5-1) through the 1/2" pre-punched hole, directly behind the 2" vent stack hole in the center of the chamber ceiling.

Note Cover the open end of injection assembly with tape to keep insulation from entering the nipple. ▲

2. Slide 3/8" flatwasher over open end of nipple.
3. Insert the covered end of the injection assembly through the exterior hole.
4. Remove the tape covering from the end of the nipple and install the 1/8" NPT brass tee on the open end of the nipple. Place Permagum sealant between the brass tee and the interior top.
5. Remove the two Phillips head screws securing the metal bracket on the vent stack assembly.
6. Install the vent stack (Figure 5-2) through the opening and secure it to the top of the freezer, using screws.
7. On the cabinet interior, seal around the end of the vent stack with Permagum.
8. Install the transfer hose connecting one end to the injection assembly, the other end to the solenoid valve. Install the solenoid valve to the supply source. The solenoid mounting bracket is not required and may be discarded.

Caution When selecting a CO₂ supply cylinder, it must be equipped with a siphon tube. ▲

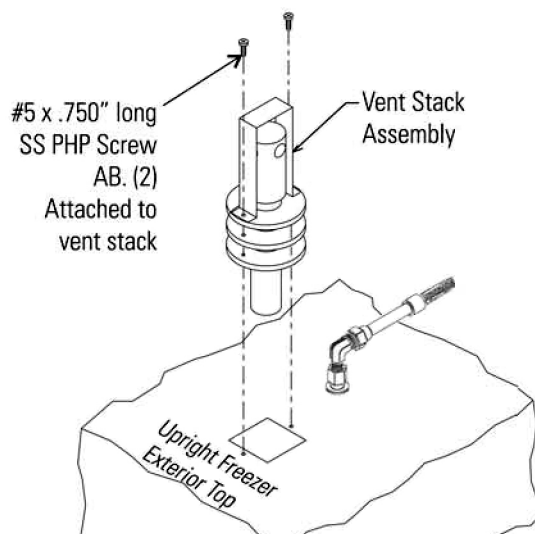

Figure 5-2. Vent Stack Assembly

Temperature Probe

1. Locate the 0.500" pre-punched hole in the upper left hand back corner of the chamber ceiling. Remove the tie wrap securing the coiled probe/solenoid harness. Uncoil the probe lead and run the probe tip (approximately 12") down through 0.500" porthole (Figure 5-4).
2. As shown in Figure 5-3, thread the small tie wrap through the openings in the front of the bracket. Secure the probe on the back of the bracket with the tie wrap.
3. Tap #8-32 the two pre-punched holes located on the interior left wall of the freezer. Mount the bracket. Figure 5-4 shows the Back-Up probe mounted on the interior left side wall of the freezer.

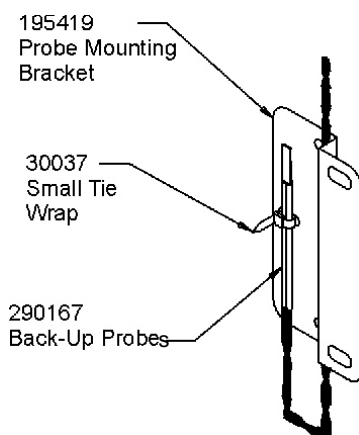

Figure 5-3. Probe

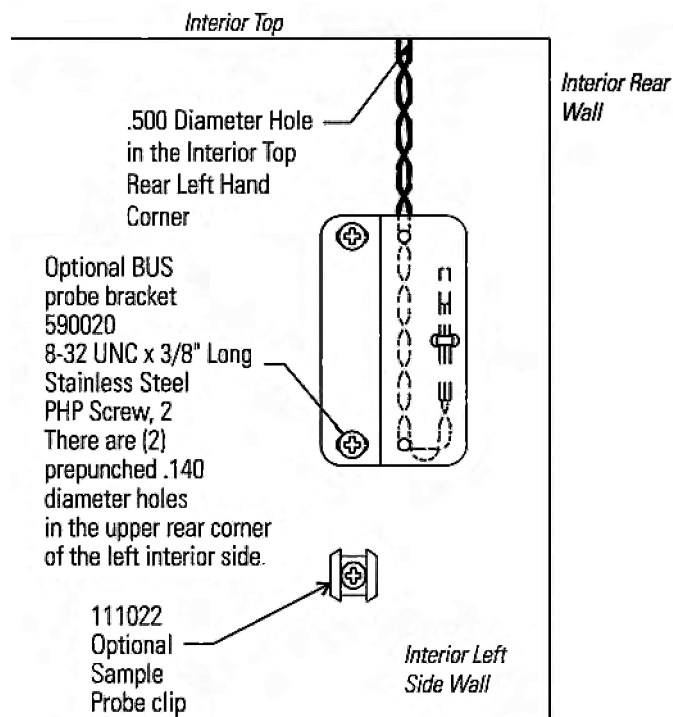

Figure 5-3. Bracket

Connect the Probe/ Solenoid Harness

1. Remove the four screws on the freezer back panel and use them to mount the tie wrap anchors as shown in Figure 5-5. Secure the probe wire with tie wraps.
2. Plug the solenoid/probe connector into the BUS connection and secure with a screw on the right and left side. The connector is keyed.
3. Loosen the terminal screws on the solenoid. Slide the spade lug connectors under the screws and tighten to secure.
4. Connect power to the freezer. Turn the freezer On, with battery switch Off (O).

a. Arming on Power On

The arming function occurs only one time at initial power-on. It may occur in 3 ways; BUS timeout arming, both sensors fail and BUS temperature sensor arming.

At power-on, the BUS will perform a Hold-off period check. The BUS will not inject the refrigerant for a Hold-off period, calculated as follows:

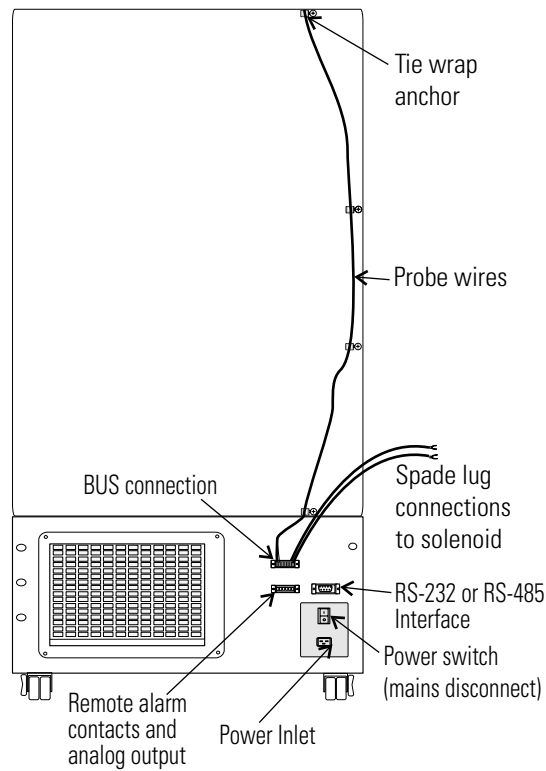

Figure 5-5. Routing

Connect the Probe/ Solenoid Harness (cont.)

Hold-off period:

- 12 hour is between 0 and +70C
- 12 hour is between 0 and (BUS Setpoint - Hysteresis)
- 0 hours is below (BUS Setpoint - Hysteresis)
- 0 hours is temperature Out Of Range or both probes fail.

b. The Low Battery indicator may also illuminate.

5. Turn the battery switch to Standby mode (⏻) to charge both batteries.

BUS Operation and Maintenance

Warning When activated, this unit injects liquid nitrogen or carbon dioxide. Liquid nitrogen can cause serious freezing (frostbite) if it comes in contact with unprotected skin or eyes. Nitrogen suppresses oxygen levels and may cause suffocation if area is not well ventilated. Refer to Appendix A for the proper handling of liquid LN₂. ▲

Caution Make sure the pressure relief valve on any LN₂ tank is adjusted to 30 PSI maximum blow-off. ▲

Warning Carbon dioxide gas suppresses oxygen levels and may cause suffocation if area is not well ventilated. Refer to “Handling Liquid CO₂” in Appendix B of this manual. ▲

Power - indicates the unit has AC power.

1. Normal Operation

- Low Battery: Illuminates only after a battery test which occurs every 8 hours. The battery test is a loaded test and during the test, the battery voltage is monitored. When the battery voltage is less than a certain threshold, this light will illuminate and stay illuminated until the next battery test.
- Solenoid Engaged: Illuminates any time the controller is activating the solenoid. Illumination will only occur when the controller senses the solenoid is active and calling for injection.

2. Fault Code

This same user interface will also permit fault codes to be easily viewed when the user presses and releases the Press to Test button in less than 2 seconds. When this occurs, both the Low Battery LED and Solenoid Engaged LED will blink twice ON/OFF quickly indicating that fault code display mode is active. For the next ~10 seconds, the fault codes will be displayed as shown in the table below. The display shows only the lower number fault code until that fault is resolved.

BUS Operation and Maintenance (cont.)

| Low Battery LED | Solenoid Engaged LED | Fault Code Number | Fault Code Definition |
|-----------------|----------------------|-------------------|-------------------------|
| OFF | OFF | 0 | Normal Operation |
| OFF | Blinks 1 time | 1 | Primary Probe Failure |
| OFF | Blinks 2 times | 2 | Secondary Probe Failure |
| OFF | Blinks 3 times | 3 | Solenoid Driver Failure |
| OFF | Blinks 4 times | 4 | Low Tank |

Table 5-1. BUS Fault Codes

Each blink will take one second, with half of the second interval being ON (illuminated) and the other half of the second interval being OFF. After the sequence concludes, both the Low Battery LED and the Solenoid Engaged LED will flash four times ON/OFF quickly to indicate a return to normal display.

3. BUS Injection Test

The user must press and hold the Press-to-Test button for ≥ 2 seconds before injection occurs. After the Press-to-Test button is pressed for >30 seconds, the solenoid will turn off. This will avoid a button or button signal becoming stuck in an active condition.

During a Press-to-Test injection, if either RTD #1 or RTD #2 reads a temperature less than 20°C below BUS set point and it is determined to be a valid input, then injection will terminate immediately.

4. BUS Set point “Validation” Feedback

Whenever the BUS set point or working fluid changes, the BUS acknowledges the set point acceptance by causing the Low Battery LED and Solenoid Engaged LED to blink three times ON/OFF quickly. This does not imply that the BUS error-checked the values, other than that the value received was within the range of the BUS working correctly with prior programming.

Note Solenoid will not engage if door is open. ▲

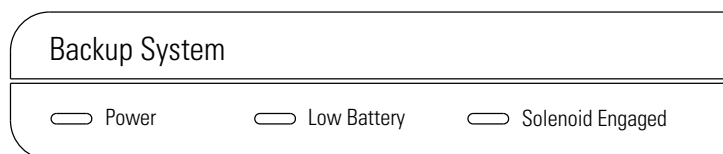

Figure 5-6. BUS Control Panel

BUS Operation and Maintenance (cont.)

Caution The back-up system is designed to inject refrigerant (CO₂ or LN₂). In the unlikely event of both probes failing, the back-up system will operate in PWM or Non-PWM mode based on jumper setting (Figure 5-7). ▲

For Hysteresis & Dual probe fault mode settings (Figure 5-7), locate Jumper J17 near to solenoid/ sensor connector (J1), refer to table below for operation details:

| Jumper PIN | Status | Hysteresis | Dual Probe Fault Mode |
|-------------------|--------------------------------------|------------|-----------------------|
| J17 PIN 1 & PIN 2 | Short Together/ Jumper Cap Installed | 5°C | Non-PWM Mode |
| J17 PIN 1 & PIN 2 | Open/No-Jumper Installed | 9°C | PWM Mode |

Table 5-2. Probe Fault Modes

PWM mode: If both probes fail, the solenoid will activate periodically, allowing the flow of refrigerant (CO₂ or LN₂).

Non-PWM mode: If both probes fail, the solenoid remains OFF and no refrigerant will flow.

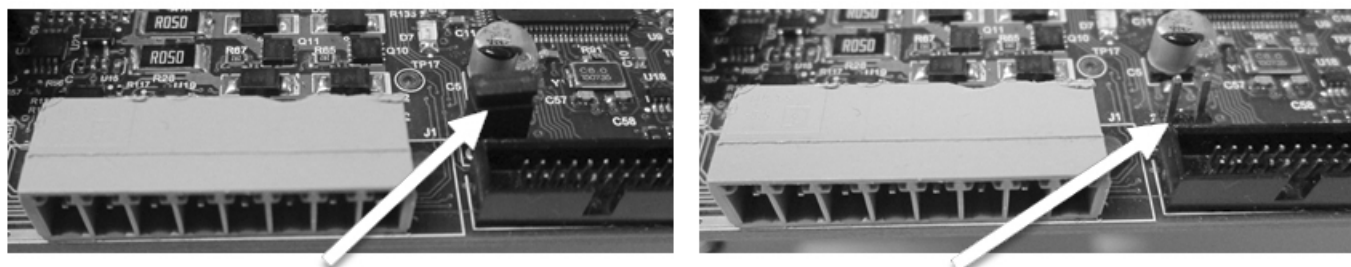

Figure 5-7. Jumper Cap for Hysteresis & Dual Probe Fault Mode Selection

Configure the Optional Back-Up System

The optional BUS can be configured for LN₂ or CO₂ supply. To select the supply type:

1. Press the Mode key until the Back-up indicator lights.
2. Press the up or down arrow key. The display will show 'Co2' for CO₂ selection and 'Ln2' for LN₂ selection.
3. Press Enter to save the setting.
4. Press the Mode key until the Run indicator lights for Run mode.

If no control keys are pressed, the freezer will automatically return to Run mode after 5 minutes.

Set the Optional Back-Up Setpoint

The optional back up system is designed to inject CO₂ or LN₂ into the freezer compartment if the temperature rises above back up system set point. To set the BUS set point:

1. Press the Mode key until the Set Temperature and Backup indicators light.
2. Press the up or down arrow key until the desired BUS set point is displayed.
3. Press Enter to save the setting.
4. Press the Mode key until the Run indicator lights for Run mode.

If no control keys are pressed, the freezer will automatically return to Run mode after 5 minutes.

Caution Changing the operating temperature set point can affect the BUS set point. The BUS set point will self adjust to maintain a temperature of at least 10°C above the operating temperature set point. ▲

Caution The BUS set point cannot be set any colder than the high temperature alarm set point (see Section 1). If the back-up system is installed with CO₂, then -65°C is the coldest BUS set point that can be used (if the cabinet set point is -75°C or colder). ▲

Test BUS Operation

After the freezer has stabilized and both batteries are fully charged, the BUS can be tested to verify proper operation.

1. Disconnect AC power to the freezer by turning the power switch off.
2. As the freezer warms up, verify the BUS injects at the desired temperature. Displayed temperature may vary by a few degrees from inject temperature due to the differences in probe locations.
3. **Preventive Maintenance** - Monthly maintenance action to check CO₂ or LN₂ back-up system operation, and battery voltage.
 - Check for fault codes on the BUS probe per Table 5-1. Also verify solenoid operation by performing a Press-To-Test.

Clean Vent Stack

Routinely check the vent stack for frost or ice build-up. The type of frost that forms in the vent stack is generally very soft and may be easily removed with a bristle brush or soft cloth. If ice build-up has occurred, a complete defrost may occasionally be required. See Section 4 for freezer defrost instructions.

Disconnect the Fitting Assembly & Transfer Hose

To disconnect the freezer back-up from the gas supply:

1. Close the supply valve.
2. Depress the test button on the BUS control box to remove the gas from the line.
3. Slowly disconnect the fitting assembly from the supply (in the event that any gas remains in the line).

Chart Recorder

Procedures concerning the use and maintenance of the optional recorder follow.

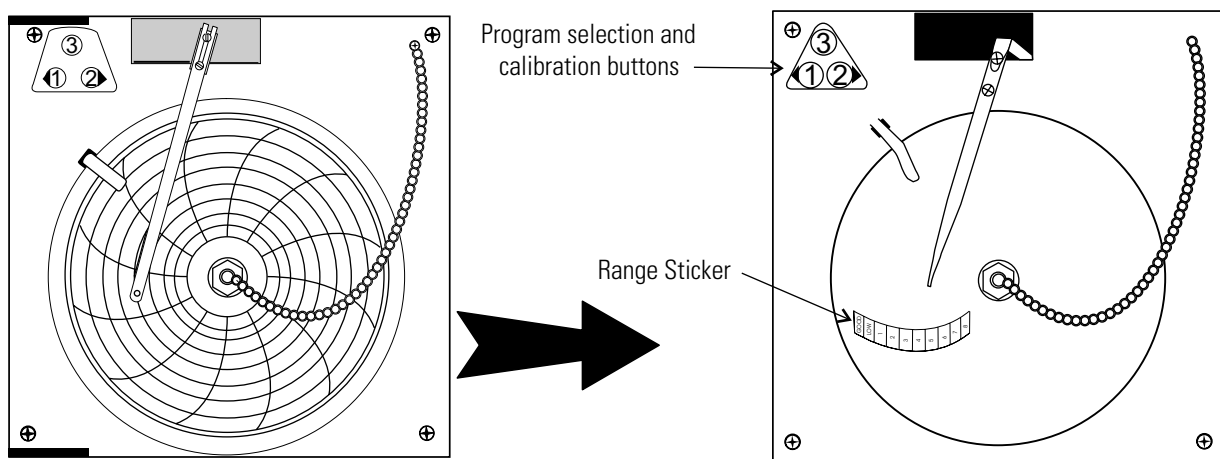

Install the Chart Paper

1. Open the glass door of the recorder and press button #3 until the pen begins to move outward.
2. Unscrew the knob at the center of the chart and remove the paper.
3. Install the new chart paper, position the paper to the correct time line and replace the knob.
4. Remove the cap from the felt pen and press button #3.



Change the Recorder Range

The chart recorder contains eight temperature ranges and is factory-programmed for the freezer.

1. Press and hold button #3 for one second, then let the pen move off the chart paper.
2. Press and hold for five seconds either button #1 or button #2.
3. Release the button and the green LED will begin to flash. Count the number of flashes to determine the present program setting.
4. To change the program setting, press the left or right arrows to increase or decrease the count.
5. When the desired program number is flashing, press button #3 to bring the pen arm back onto the chart. Recording will begin in the new program.

| Program | From | To |
|---------|------|-------|
| 1 | -40 | 30°C |
| 2 | 0 | 60°C |
| 3 | -100 | 38°C |
| 4 | -5 | 50°C |
| 5 | 0 | 100°C |
| 6 | -100 | 200°C |
| 7 | -115 | 50°C |
| 8 | -10 | 70°C |

Table 5-3. Recorder Temp Range

Calibrate the Chart Recorder

Caution The recorder must be in service for 24 hours before performing the following calibration procedure. ▲

1. Place an accurate thermometer in the chamber next to the recorder probe.
2. Temperature probes for the recorder are located in the left front corner of the freezer chamber (Figure 1-4).
3. After about three minutes, compare the thermometer reading with the chart recorder reading.
4. If an adjustment is necessary, press the #1 button to move the pen to the left or the #2 to move the pen to the right. The button must be held about five seconds before the pen begins to move. Release the button when the pen position matches the thermometer.

Note The felt-tip pen on the recorder requires periodic replacement. Usually the ink will appear to fade before replacement becomes necessary. Additional pen tips may be purchased from Thermo. ▲

Five Inner Door Option

The five inner door option (P/N 189405, 189406, 189407, 195652) is factory installed. The freezer is converted to accommodate four adjustable specimen shelves with the fifth “shelf” as the bottom of the freezer chamber.

Section 5
Factory Options

Section 6 Specifications

| Number | TSD40240A | TSD40240V | TSD40240D |
|-----------------------------------|---|--|---|
| Temperature Range | -10°C (14°F) to -40°C (-40°F) | | |
| Exterior Dimensions | 33.3"W x 77.9"H x 32.9" 84.6 x 197.9 x 83.6cm | 33.3"W x 77.9"H x 32.9" 84.6 x 197.9 x 83.6cm | 33.3"W x 77.9"H x 32.9" 84.6 x 197.9 x 83.6cm |
| Interior Dimensions | 23.0"W x 51.5"H x 19.3" 58.4 x 130.8 x 49.0cm | 23.0"W x 51.5"H x 19.3" 58.4 x 130.8 x 49.0cm | 23.0"W x 51.5"H x 19.3" 58.4 x 130.8 x 49.0cm |
| Capacity | 13.0 cu. ft. (368.1 liters) | 13.0 cu. ft. (368.1 liters) | 13.0 cu. ft. (368.1 liters) |
| Refrigeration | One 1 HP (2545 BTUH each) | | |
| Insulation | Non-CFC, foamed-in-place urethane: 5.0" (12.7cm) cabinet; 4.5" (11.4 cm) door | | |
| Electrical - nominal voltage ±10% | 120V, 60Hz, 10.0 FLA Operating Range: 108V-130VAC | 230V, 50 Hz, 6.5 FLA Operating Range: 208-230VAC | 208-230V, 60Hz, 6.5 FLA Operating Range: 208-240VAC |
| Breaker Requirements | 15 amp Dedicated Circuit, 15 Amp Time Delay Breaker | 15 amp Dedicated Circuit, 15 Amp Time Delay Breaker | 15 amp Dedicated Circuit, 15 Amp Time Delay Breaker |
| Shipping Weight: Motor | 696 lbs. (316 kg) | 696 lbs. (316 kg) | 696 lbs. (316 kg) |

| Number | TSD40320A | TSD40320V | TSD40320D |
|-----------------------------------|---|---|---|
| Temperature Range | -10°C (14°F) to -40°C (-40°F) | | |
| Exterior Dimensions | 33.3"W x 77.9"H x 38.9" 84.6 x 197.9 x 98.8cm | 33.3"W x 77.9"H x 38.9" 84.6 x 197.9 x 98.8cm | 33.3"W x 77.9"H x 38.9" 84.6 x 197.9 x 98.8cm |
| Interior Dimensions | 23.0"W x 51.5"H x 25.3" 58.4 x 130.8 x 64.3cm | 23.0"W x 51.5"H x 25.3" 58.4 x 130.8 x 64.3cm | 23.0"W x 51.5"H x 25.3" 58.4 x 130.8 x 64.3cm |
| Capacity | 17.3 cu. ft. (489.9 liters) | 17.3 cu. ft. (489.9 liters) | 17.3 cu. ft. (489.9 liters) |
| Refrigeration | One 1 HP (2545 BTUH each) | | |
| Insulation | Non-CFC, foamed-in-place urethane: 5.0" (12.7cm) cabinet; 4.5" (11.4 cm) door | | |
| Electrical - nominal voltage ±10% | 120V, 60 Hz, 10.0 FLA Operating Range: 108VAC-130VAC | 230V, 50 Hz, 6.5 FLA Operating Range: 208VAC-230VAC | 208-230V, 60 Hz, 6.5 FLA Operating Range: 208VAC-230VAC |
| Breaker Requirements | 15 amp Dedicated Circuit, 15 amp Time Delay Breaker | 15 amp Dedicated Circuit, 15 amp Time Delay Breaker | 15 amp Dedicated Circuit, 15 amp Time Delay Breaker |
| Shipping Weight: Motor | 810 lbs. (367 kg) | 810 lbs. (367 kg) | 810 lbs. (367 kg) |

Section 6
Specifications

| Number | TSD40400A | TSD40400V | TSD40400D |
|--|---|---|--|
| Temperature Range | -10°C (14°F) to -40°C (-40°F) | | |
| Exterior Dimensions | 40.8"W x 77.9"H x 38.9" 103.6 x 197.9 x 98.8 cm | 40.8"W x 77.9"H x 38.9" 103.6 x 197.9 x 98.8 cm | 40.8"W x 77.9"H x 38.9" 103.6 x 197.9 x 98.8 cm |
| Interior Dimensions | 30.6"W x 51.5"H x 25.3" 77.7 x 130.8 x 64.3 cm | 30.6"W x 51.5"H x 25.3" 77.7 x 130.8 x 64.3 cm | 30.6"W x 51.5"H x 25.3" 77.7 x 130.8 x 64.3 cm |
| Capacity | 23.0 cu. ft. (651.3 liters) | 23.0 cu. ft. (651.3 liters) | 23.0 cu. ft. (651.3 liters) |
| Refrigeration | One 1 HP (2545 BTUH each) | | |
| Insulation | Non-CFC, foamed-in-place urethane: 5.0" (12.7cm) cabinet; 4.5" (11.4 cm) door | | |
| Electrical - nominal voltage $\pm 10\%$ | 120V, 60 Hz, 10.0 FLA Operating Range: 108VAC-130VAC | 230V, 50Hz, 12.0 FLA Operating Range: 208VAC-240VAC | 208-230V, 60 Hz, 12.0 FLA Operating Range: 208VAC-240VAC |
| Breaker Requirements | 15 amp Dedicated Circuit, 15 amp Time Delay Breaker | 15 amp Dedicated Circuit, 15 amp Time Delay Breaker | 15 amp Dedicated Circuit, 15 amp Time Delay Breaker |
| Shipping Weight: Motor | 920 lbs. (417 kg) | 920 lbs. (417 kg) | 920 lbs. (417 kg) |

Certifications

2004/108/EC Electromagnetic Compatibility Directive

3006/95/EC Low Voltage Directive

2011/65/EL RoHS

Declaration of Conformity and Directives are available on request

Safety Specifications

Indoor Use Only

Altitude - Up to 2,000 meters

Temperature - 5°C to 43°C

Humidity - Maximum RH 80% for temperatures up to 31°C, decreasing linearly to 50% RH at 40°C

Mains Supply Fluctuations - Mains supply voltage fluctuations not to exceed $\pm 10\%$ of the nominal voltage

Installation Category II ¹

Pollution Degree 2 ²

Class of Equipment I

Fluorinated Greenhouse Gases

Compliant with REGULATION (EU) No 517/2014 OF THE EUROPEAN PARLIAMENT AND OF THE COUNCIL on fluorinated greenhouse gases. This product contains fluorinated greenhouse gases in a hermetically sealed system. This product contains foam blown with fluorinated greenhouse gas, R-245fa. If a leak in the sealed system is detected, the operator shall repair without undue delay.

For ULT models rated 230V/50Hz, intended for import into the EU, the following sizes are designed for use with the following amounts of fluorinated greenhouse gases:

| Size (ft ³) | 1st Stage | | |
|-------------------------|-------------|-------------|-------|
| | Refrigerant | Amount (kg) | GWP |
| 13 | R-404a | 0.595 | 3 922 |
| 17 | R-404a | 0.624 | 3 922 |
| 23 | R-404a | 0.624 | 3 922 |

¹ Installation category (overvoltage category) defines the level of transient overvoltage which the instrument is designed to withstand safely. It depends on the nature of the electricity supply and its overvoltage protection means. For example, in CAT II which is the category used for instruments in installations supplied from a supply comparable to public mains such as hospital and research laboratories and most industrial laboratories, the expected transient overvoltage is 2500V for a 230V supply and 1500V for a 120V supply.

² Pollution degree describes the amount of conductive pollution present in the operating environment. Pollution degree 2 assumes that normally only non-conductive pollution such as dust occurs with the exception of occasional conductivity caused by condensation.

103308, 13 & 17 CF DOOR GASKET
 103309, 23 CF DOOR GASKET
 103310, 28 CF DOOR GASKET

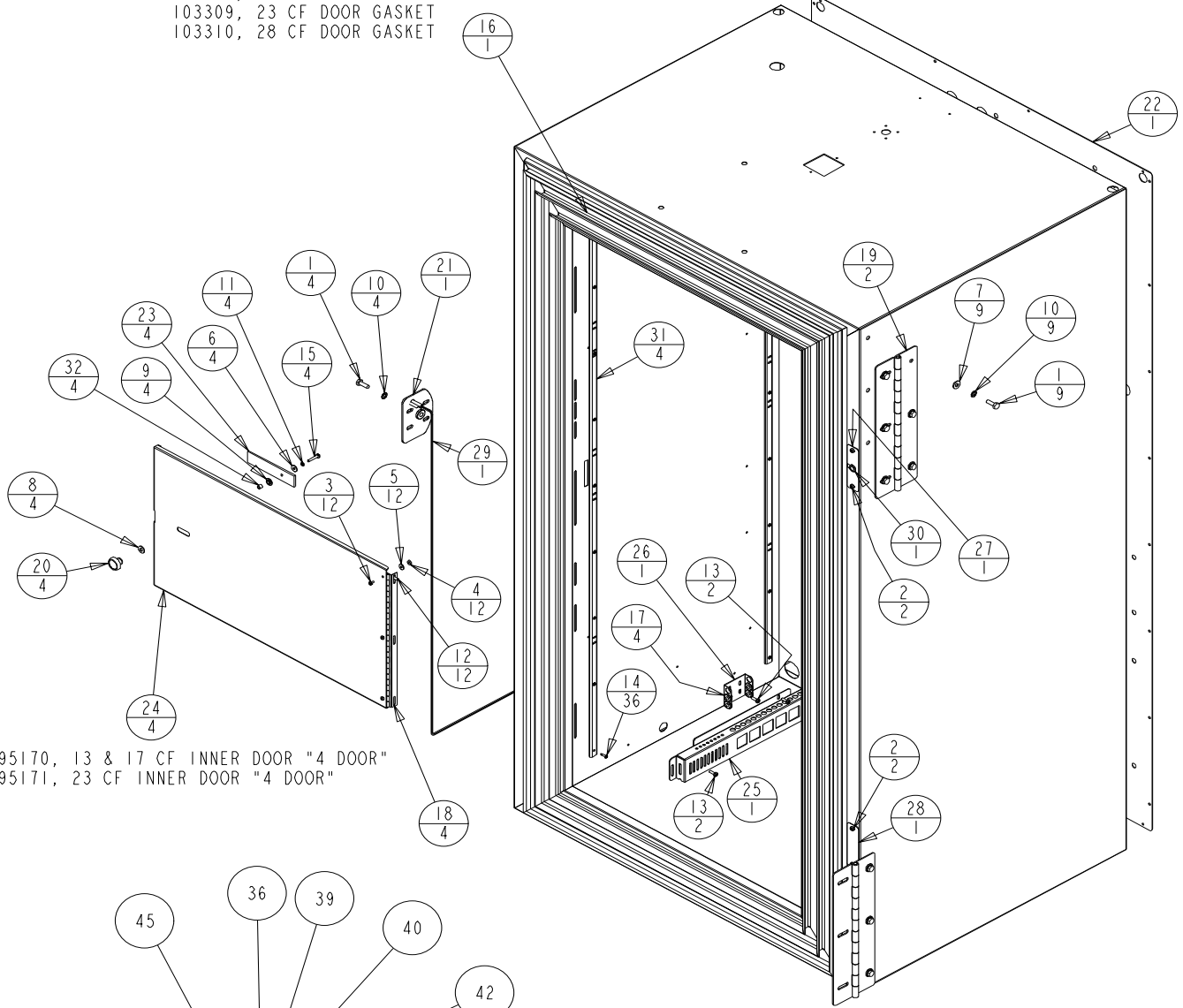

195170, 13 & 17 CF INNER DOOR "4 DOOR"
 195171, 23 CF INNER DOOR "4 DOOR"

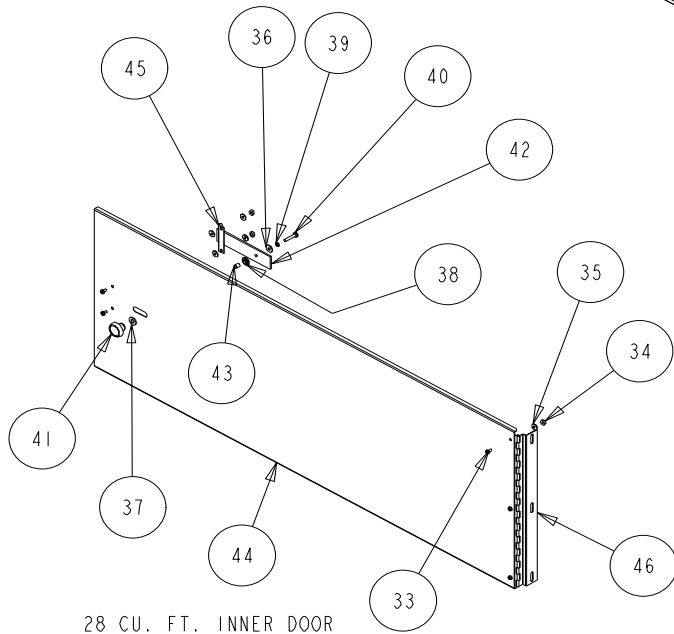

28 CU. FT. INNER DOOR

**UPRIGHT FREEZER
 ASSEMBLY**

902-200-1-B REV 4
 PAGE 1 OF 2

Section 7
Parts List

| BILL OF MATERIALS | | |
|-------------------|----------|---------------------------------------|
| ITEM NO. | PART NO. | PART DESCRIPTION |
| 1 | 20003 | 1/4-20 X 3/4 SS HH CAP SCREW |
| 2 | 22053 | #8-32 X 1/2 SS PHP SCREW |
| 3 | 22115 | #6-32 X 1/4 SS PHP SCREW |
| 4 | 23009 | #6-32 SS HEX NUT |
| 5 | 23020 | #6 SS FLAT WASHER |
| 6 | 23021 | #8 SS FLAT WASHER |
| 7 | 23023 | 1/4 SS FLAT WASHER |
| 8 | 23043 | NYLON FLAT WASHER |
| 9 | 23044 | 1/4" NYLON SHOULDER WASHER |
| 10 | 23062 | 1/4 SS EXT TOOTH LOCKWASHER |
| 11 | 23080 | #8 SS SPRING LOCKWASHER |
| 12 | 24032 | #8-32 X 3/8 SS PHP SCREW F POINT |
| 13 | 24042 | #8-32 X 1/2 SS PHP SCREW F POINT |
| 14 | 25018 | 1/8 X 1/4 SS POP RIVET |
| 15 | 59008 | #8-32 X 7/8 SS PHP SCREW |
| 16 | 103308 | 13/17 CU.FT. SINGLE DOOR FRAME GASKET |
| 17 | 114020 | 5/8" X 1/2" ID GROMMET |
| 18 | 116077 | FRONT PANEL HINGE |
| 19 | 116092 | EXTERIOR FREEZER DOOR HINGE |
| 20 | 120400 | BLACK PLASTIC KNOB |
| 21 | 121099 | FRZ CAM LATCH STRIKE |
| 22 | 189921 | EXTERIOR BACK 13 & 17 |
| 23 | 195169 | LATCH TAB |
| 24 | 195170 | 13/17 CU.FT. INNER DOOR |
| 25 | 195866 | PROBE GUARD |
| 26 | 195867 | PROBE MOUNT |
| 27 | 195830 | UR DOOR WIREWAY COVER PLATE |
| 28 | 195900 | MAGNETIC SWITCH |
| 29 | 30033 | RT. ANGLE STRAIN RELIEF |
| 30 | 500177 | PILASTER STRIPS |
| 31 | 515083 | 1/4 DIA. X 1/4L SS SPACER |
| 32 | 22115 | #6-32 X 1/4 SS PHP SCREW |
| 33 | 23009 | #6-32 SS HEX NUT |
| 34 | 23020 | #6 SS FLAT WASHER |
| 35 | 23021 | #8 SS FLAT WASHER |
| 36 | 23043 | NYLON FLAT WASHER |
| 37 | 23044 | 1/4" NYLON SHOULDER WASHER |
| 38 | 23080 | #8 SS SPRING LOCKWASHER |
| 39 | 59008 | #8-32 X 7/8 SS PHP SCREW |
| 40 | 120400 | BLACK PLASTIC KNOB |
| 41 | 195169 | LATCH TAB |
| 42 | 515083 | 1/4 DIA. X 1/4L SS SPACER |
| 43 | 1950217 | 28 CU. FT. INNER DOOR |
| 44 | 1950218 | 28 CU.FT. INNER DOOR LATCH GUIDE |
| 45 | 116090 | FRONT PANEL HINGE |
| 46 | 24030 | 8 X 1/2 ZP PHP SCREW TEKS |

UPRIGHT FREEZER
ASSEMBLY

902-200-1-B REV 4
PAGE 2 OF 2

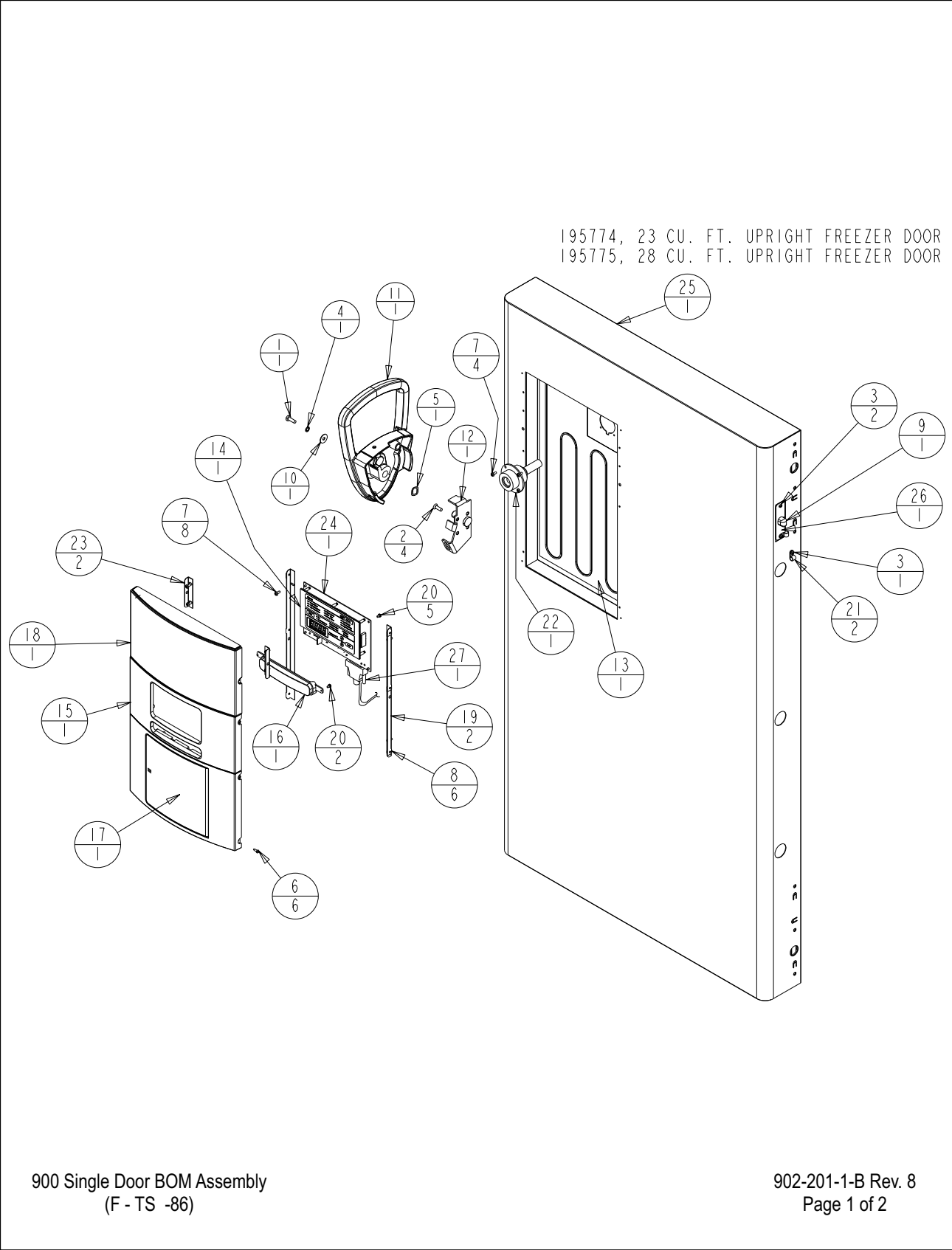

Section 7
Parts List

| BILL OF MATERIALS | | |
|-------------------|----------|--|
| ITEM NO. | PART NO. | PART DESCRIPTION |
| 1 | 20003 | 1/4-20 X 3/4 SS HH CAP SCREW |
| 2 | 20058 | #1/4-20 X 3/4 SS FHP UC SCREW |
| 3 | 22053 | #8-32 X 1/2 SS PHP SCREW |
| 4 | 23033 | 1/4 SS INTERNAL TOOTH LOCK WASHER |
| 5 | 23057 | 5/8 WAVE WASHER |
| 6 | 24016 | #6 X 1/2" SS PHP SCREW AB POINT |
| 7 | 24032 | #8-32 X 3/8 SS PHP SCREW F POINT |
| 8 | 25040 | #6 U SPEED NUT STL. STL. |
| 9 | 30033 | RIGHT ANGLE STRAIN RELIEF |
| 10 | 121092 | .856" OD FLAT WASHER |
| 11 | 121098 | FINISHED HANDLE/LATCH ASSEMBLY "WHT" |
| 12 | 121102 | CAM LATCH MOUNT |
| 13 | 132114 | HEATER, 3W, 14VDC |
| 14 | 140444 | CONTROL PANEL ASSEMBLY |
| 15 | 180305 | CONTROL CENTER DISPLAY BEZEL "SID BLU" |
| 16 | 180306 | THERMO BACK-UP SYSTEM BLANK PANEL "SID BLUE" |
| 17 | 180308 | CONTROL CENTER RECORDER BLANK "SID BLU" |
| 18 | 180360 | CONTROL BLANK PANEL "SID BLUE" |
| 19 | 195837 | MOUNTING ANGLE FOR 180305 |
| 20 | 590027 | #6-32 X 1/4 SS PHP EXT SEMS SCREW |
| 21 | 600085 | 5/16 NYLON CABLE CLAMP |
| 22 | 1950069 | HEATED VACUUM RELIEF PORT |
| 23 | 1950492 | MOUNTING ANGLE |
| 24 | 191956 | FREEZER DISPLAY BOARD |
| 25 | 195773 | 13 & 17 CU. FT. UPRIGHT FREEZER DOOR |
| 26 | 195830 | UPRIGHT DOOR WIREWAY COVER PLATE |
| 27 | 430336 | 15 FT, RS-232 CABLE 25 POS. |

900 Single Door BOM Assembly
(F - TS -86)

902-201-1-B Rev. 8
Page 2 of 2

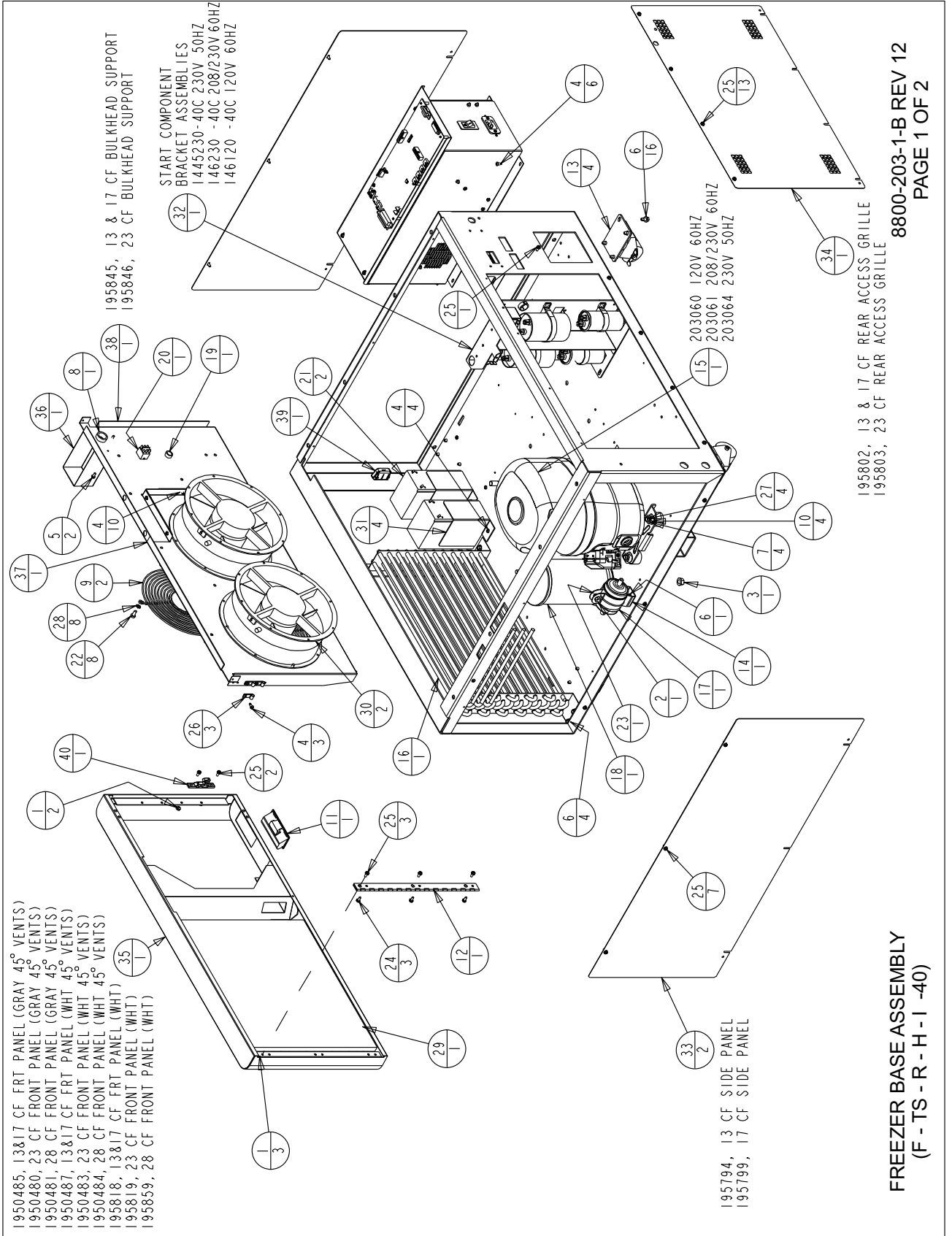

8800-203-1-B REV 12
PAGE 1 OF 2

FREEZER BASE ASSEMBLY
(F - TS - R - H - I - 40)

| BILL OF MATERIALS | | |
|-------------------|----------|---|
| ITEM NO. | PART NO. | PART DESCRIPTION |
| 1 | 23002 | #8-32 ZP LKWASH HEX NUT |
| 2 | 23011 | 1/4-20 ZP LKWASH HEX NUT |
| 3 | 23013 | 3/8-16 ZP LKWASH HEX NUT |
| 4 | 24030 | #8 X 1/2" TKS SCREW |
| 5 | 24032 | #8-32 X 3/8 SS PHP SCREW F POINT |
| 6 | 24038 | 1/4-20 X 1/2 SELF TAPPING SCREW |
| 7 | 24049 | 1/4 ZP FLAT WASHER |
| 8 | 30016 | 1" SNAP BUSHING |
| 9 | 108020 | 10" WIRE FAN GUARD |
| 10 | 114034 | COMPRESSOR MOUNTING SLEEVE |
| 11 | 115032 | BLACK ABS PLASTIC PULL |
| 12 | 116115 | FRONT PANEL HINGE |
| 13 | 120011 | DUAL WHEEL CASTER |
| 14 | 200126 | 2" RIGID HANGER |
| 15 | 203060 | BRISTOL HIGH/LOW STAGE COMPRESSOR |
| 16 | 204009 | REFRIGERATION CONDENSER |
| 17 | 209020 | LIQUID LINE FILTER DRYER WITH ACCESS PORT |
| 18 | 214023 | OIL SEPARATOR |
| 19 | 330002 | 5/8" SNAP BUSHING |
| 20 | 360248 | MINI SNAP-IN POWER SWITCH |

| BILL OF MATERIALS (CONTINUED) | | |
|-------------------------------|-------------|--|
| ITEM NO. | PART NO. | PART DESCRIPTION |
| 21 | 400159 | SEALED LEAD ACID BATTERY - 12 VOLT - 7.2 Ah |
| 22 | 510035 | #12-24 X 1/2 SS HH CAP SCREW |
| 23 | 550043 | 1/4-20 X 1" L ZP CARRIAGE BOLT |
| 24 | 590020 | #8-32 X 3/8 SS PHP EXT SEMS SCREW |
| 25 | 590029 | #8-32 X 3/8 SS PHP EXT SEMS SCREW W/PATCH |
| 26 | 600080 | 1/4 ALUM CLAMP W/LINER |
| 27 | 680008 | 1/4-20 X 1-3/4 SELF TAPPING SCREW |
| 28 | 730087 | #12 SS EXT TOOTH LOCKWASHER |
| 29 | 760203 | AIR FILTER |
| 30 | 900113 | 10" TUBEAXIAL FAN, 115V |
| 31 | 1950074 | BATTERY MOUNTING BRACKET |
| 32 | 120230-01-2 | URIGHT FREEZER START COMPONENT BRACKET ASSY. |
| 33 | 195799 | SIDE PANEL 17, 23 AND 28 CU. FT. UPRIGHT |
| 34 | 195802 | 13/17 REAR ACCESS GRILLE |
| 35 | 195818-16-1 | 13&17 CU. FT. UR FRZ BASE FRONT PNL |
| 36 | 195829 | MULLION/DOOR SWITCH WIRE COVER |
| 37 | 195844 | UR FRZ FAN BULKHEAD |
| 38 | 195845 | 13&17 CU. FT. FAN BULKHEAD SUPPORT |
| 39 | 319388 | LATCH CATCH, PART OF 319388 ASSEMBLY |
| 40 | 319388 | LATCH KEEPER, PART OF 319388 ASSEMBLY |

FREEZER BASE ASSEMBLY
(F - TS - R - H - I - 40)

8800-203-1-B REV 12
PAGE 2 OF 2

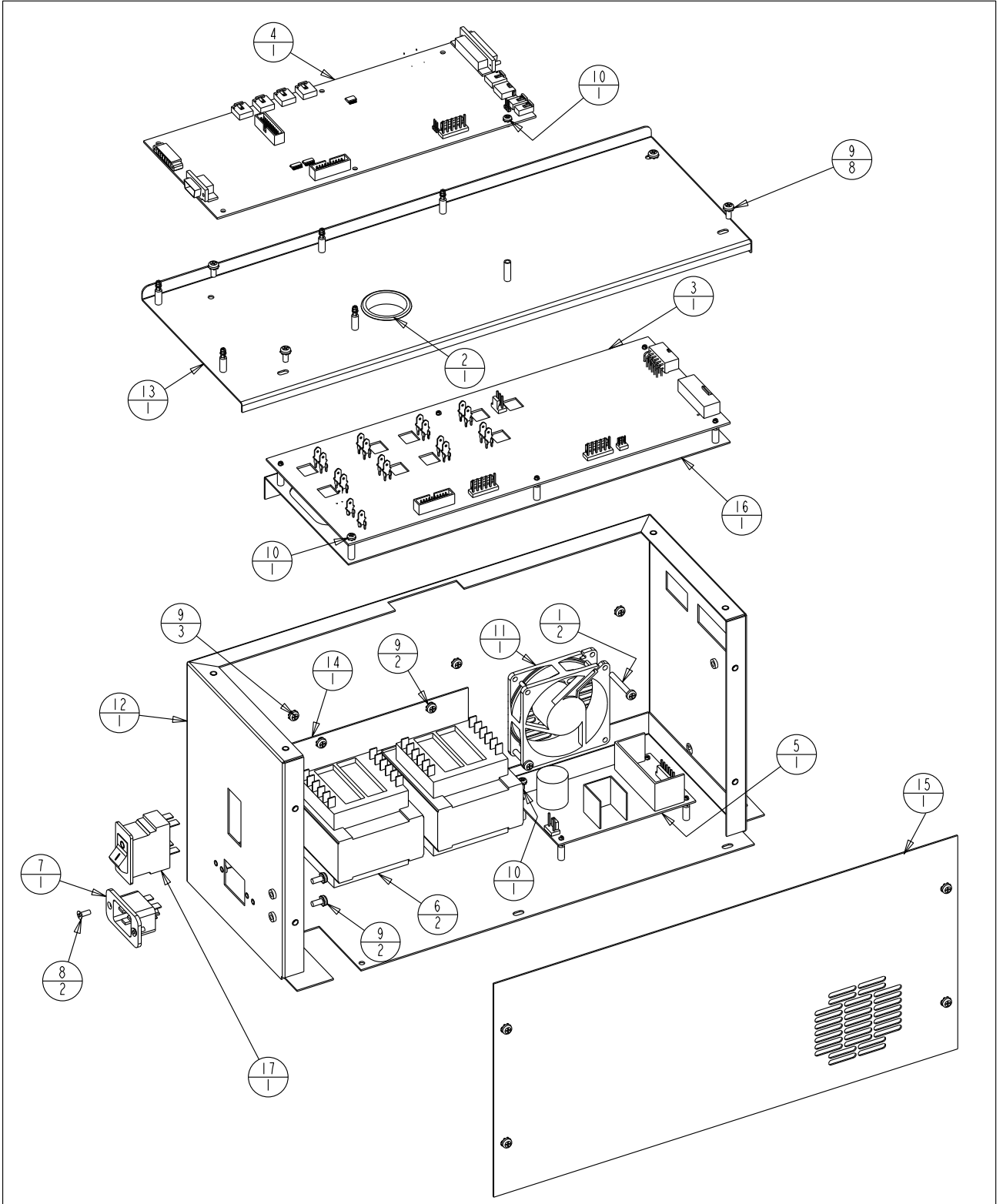

230V RELAY ENCLOSURE ASSEMBLY

Section 7
Parts List

| BILL OF MATERIALS | | |
|-------------------|-------------|---------------------------------------|
| ITEM NO. | PART NO. | PART DESCRIPTION |
| 1 | 22143 | #8-32 x 1-1/4 SS PHP SCREW |
| 2 | 30077 | 1-1/2" SNAP BUSHING |
| 3 | 191923 | HIGH VOLTAGE BOARD 230V |
| 4 | 191989 | MICRO BOARD (HIGH END) |
| 5 | 400165 | SWITCHER BOARD |
| 6 | 420090 | 175V TRANSFORMER |
| 7 | 460169 | POWER INLET, 16/20A |
| 8 | 490009 | #6-32 X 3/8 SS FHP UC SCREW |
| 9 | 590020 | #8-32 X 3/8 SS PHP EXT SEMS SCREW |
| 10 | 590027 | #6-32 X 1/4 SS PHP EXT SEMS SCREW |
| 11 | 900134 | TUBEAXIAL FAN, 30 CFM, 12V |
| 12 | 195631-16-1 | RELAY ENCLOSURE SPOTWELD SUB-ASSEMBLY |
| 13 | 195631-16-4 | RELAY ENCLOSURE COVER/191656 SUPPORT |
| 14 | 195631-31-3 | TRANSFORMER HOLD DOWN |
| 15 | 195631-31-5 | RELAY ENCLOSURE COVER (MAIN) |
| 16 | 195730-16-1 | 191658 SUPPORT BRACKET SUB-ASSEMBLY |
| 17 | 230184 | 15A DPDT SWITCH/CIRCUIT BKR |

I. COMMON TO: 1950124 & 1950128

230V RELAY ENCLOSURE ASSEMBLY

902-204-1-B Rev. 2
Page 2 of 2

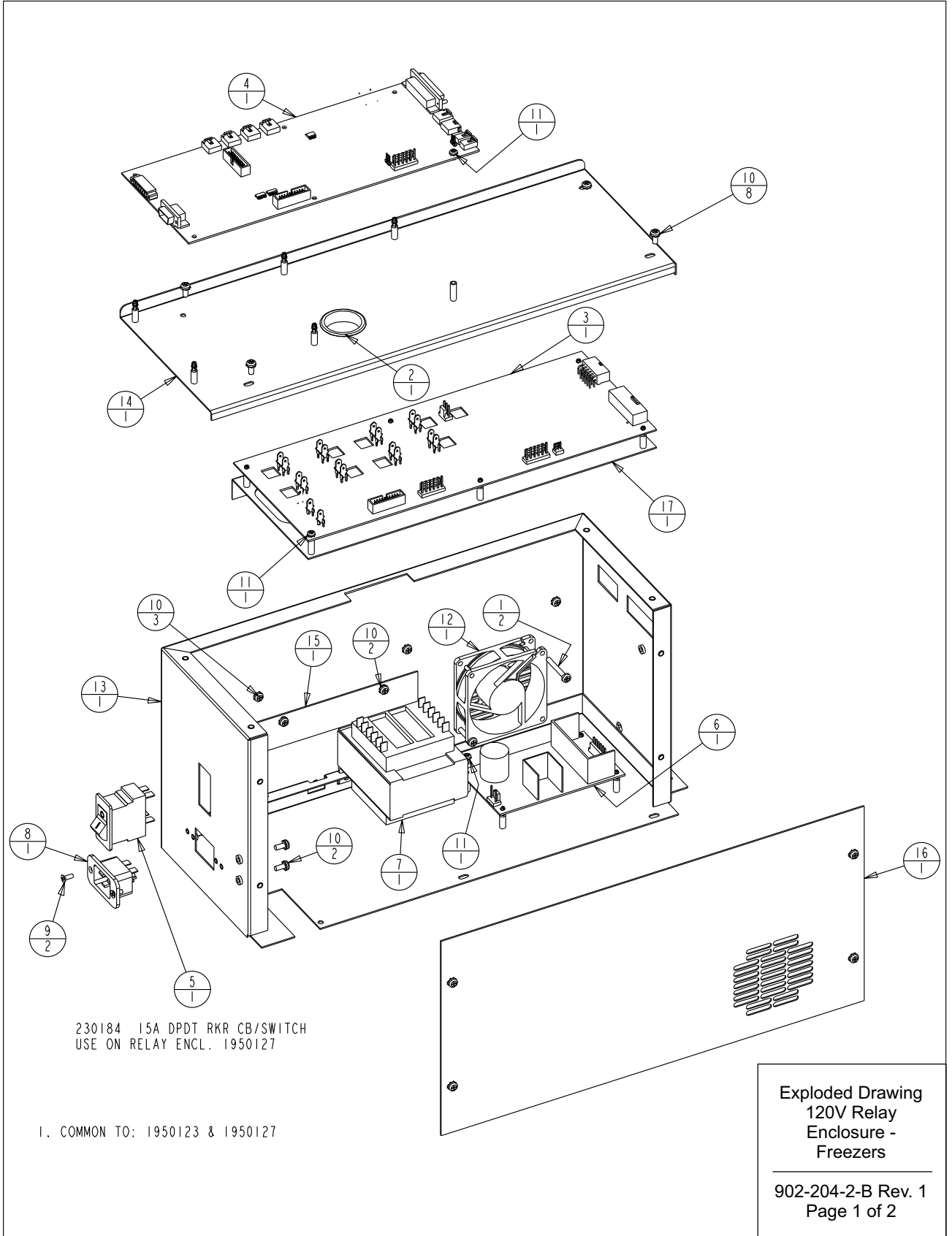

Section 7
Parts List

| REV | ECN NO. | DATE | BY | CAD | APPD | DESCRIPTION OF REVISION |
|-----|---------|----------|-----|-----|------|---|
| 0 | FR-2202 | 06-23-11 | KDG | KDG | DRP | RELEASED FOR PRODUCTION / REL. 6 |
| 1 | FR-2409 | 10-10-12 | AJC | KDG | CCS | REMOVED 1950121 & 1950125 LOW END BOXES |

| BILL OF MATERIALS | | |
|-------------------|-------------|---------------------------------------|
| ITEM NO. | PART NO. | PART DESCRIPTION |
| 1 | 22143 | #8-32 x 1-1/4 SS PHP SCREW |
| 2 | 30077 | 1-1/2" SNAP BUSHING |
| 3 | 191932 | HIGH VOLTAGE BOARD 120V |
| 4 | 191989 | MICRO BOARD (HIGH END) |
| 5 | 230183 | 20A DPDT SWITCH/CIRCUIT BKR |
| 6 | 400165 | SWITCHER BOARD |
| 7 | 420065 | 175V TRANSFORMER |
| 8 | 460169 | POWER INLET, 16/20A |
| 9 | 490009 | #6-32 X 3/8 SS FHP UC SCREW |
| 10 | 590020 | #8-32 X 3/8 SS PHP EXT SEMS SCREW |
| 11 | 590027 | #6-32 X 1/4 SS PHP EXT SEMS SCREW |
| 12 | 900134 | TUBEAXIAL FAN, 30 CFM, 12V |
| 13 | 195631-16-1 | RELAY ENCLOSURE SPOTWELD SUB-ASSEMBLY |
| 14 | 195631-16-4 | RELAY ENCLOSURE COVER/191656 SUPPORT |
| 15 | 195631-31-3 | TRANSFORMER HOLD DOWN |
| 16 | 195631-31-5 | RELAY ENCLOSURE COVER (MAIN) |
| 17 | 195730-16-1 | 191658 SUPPORT BRACKET SUB-ASSEMBLY |

THIS DOCUMENT CONTAINS PROPRIETARY INFORMATION AND SUCH INFORMATION IS NOT TO BE DISCLOSED TO OTHERS FOR ANY PURPOSE NOR USED FOR MANUFACTURING PURPOSE WITHOUT WRITTEN PERMISSION FROM THERMO FISHER SCIENTIFIC

ThermoFisher
SCIENTIFIC

BOX 649, MARIETTA, OHIO 45750

MODEL/PART NAME: RELAY ENCLOSURE ASSEMBLY

DWG TITLE: 120 VOLT RELAY ENCLOSURE ASSY

DWN: KDG CAD: KDG APPD: DRP DATE: 06-23-11 SCALE: 0.250

MATERIAL: -

PAINT: N/A

TOLERANCE UNLESS OTHERWISE SPECIFIED
ANGLES: DECIMAL: .XX±
.XXX±

DRAWING NUMBER

902-204-2

SIZE

B

Exploded Drawing
120V Relay
Enclosure -
Freezers

902-204-2-B Rev. 1
Page 2 of 2

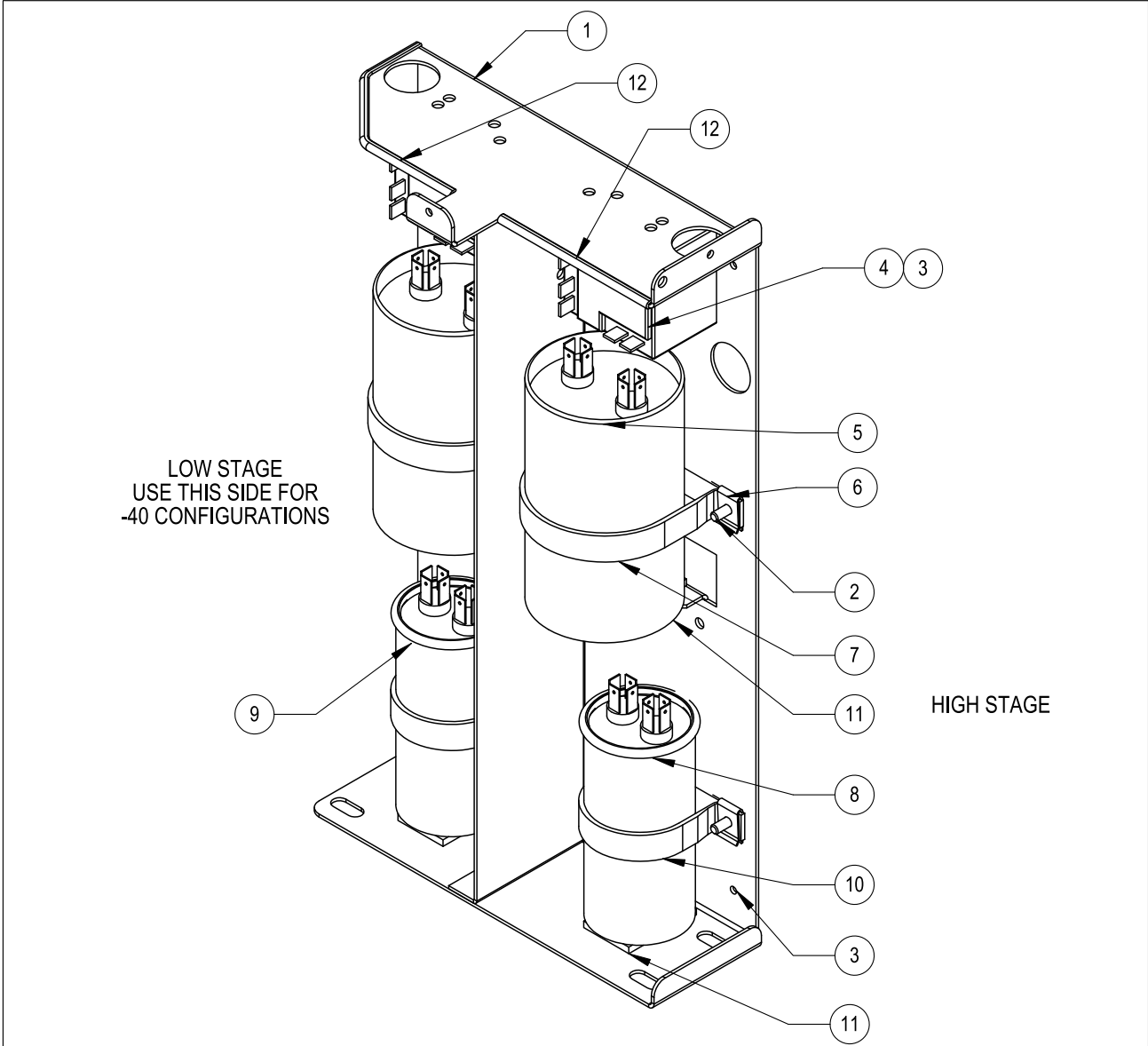

LOW STAGE
USE THIS SIDE FOR
-40 CONFIGURATIONS

HIGH STAGE

NOTES:

1. SEE PSS 8602-724-012 FOR ASSEMBLY WIRING AND OTHER DETAILS.
2. AFTER ATTACHING NOMEX COVER (250138) WITH SCREWS (590029), STICK ESD LABEL (220555) TO OUTSIDE OF COVER.
3. IDENTIFY EACH ASSEMBLY WITH LABELS ON THE BOTTOM AND BACK THAT INCLUDE THE FOLLOWING:
 FIRST LINE - ASSEMBLY NUMBER AND REVISION
 SECOND LINE - BAR CODE OF ASSEMBLY AND REVISION
 THIRD LINE - UNIQUE SERIAL NUMBER INCLUDING DATE OF MANUFACTURE IN THE FOLLOWING FORMAT AND ORDER:
 THREE LETTER MANUFACTURING SITE, TWO DIGIT YEAR MANUFACTURED, TWO DIGIT WEEK MANUFACTURED FOLLOWED
 BY A UNIQUE FOUR DIGIT NUMBER.
 FOURTH LINE - BAR CODE OF UNIQUE SERIAL NUMBER.
 FIFTH LINE - ASSEMBLY DESCRIPTION IN THE FOLLOWING FORMAT: UPRIGHT, TEMPERATURE, VOLTAGE AND FREQUENCY.

Upright Freezer Start Component
Enclosure Assembly

120230-01-2-D Rev 10
Page 1 of 2

Section 7
Parts List

| UPRIGHT FREEZER START COMPONENT BRACKET ASSEMBLIES | | | | | | | |
|--|--|----------------------------|-------------------------------|----------------------------|----------------------------|------------------------------|---------------------------|
| ITEM NO. | DESCRIPTION | 1823050 -86C 230V 50 Hz | 1823060 -86C 208/230V 60Hz | 1812060 -86C 120V 60 Hz | 1445230 -40C 230V 50 Hz | 146230 -40C 208/230V 60Hz | 146120 -40C 120V 60 Hz |
| 1 | COMPONENT BRACKET | 120230 | 120230 | 120230 | 120230 | 120230 | 120230 |
| 2 | #8 X 1/2 PHP TYPE AB | 24021 (4) | 24021 (4) | 24021 (4) | 24021 (2) | 24021(2) | 24021 (2) |
| 3 | 8-32 X 3/8 SCREW | 590020 (4) | 590020 (4) | 590020 (4) | 590020 (2) | 590020 (2) | 590020 (2) |
| 4 | START RELAY | 312286 (2) | 312186 (2) | 312086 (2) | 312287 (1) | 312187 (1) | 312087 (1) |
| 5 | START CAPACITOR | 623050 (2) | 623060 (2) | 612060 (2) | 170236 (1) | 170154 (1) | 170154 (1) |
| 6 | #8 SPEED NUT, S.S. | 327675 (4) | 327675 (4) | 327675 (4) | 327675 (2) | 327675 (2) | 327675 (2) |
| 7A | 2.5" VINYL COATED STRAP | N/A | N/A | 600106 (4) | N/A | N/A | 600106 (2) |
| 7B | 2" VINYL COATED STRAP | 600108 (2) | 600108 (2) | N/A | 600108 (1) | 600108 (1) | N/A |
| 8 | RUN CAPACITOR | 223050 | 223060 | 212060 | N/A | N/A | N/A |
| 9 | RUN CAPACITOR | 223050 | 223050 | 212060 | 170097 (1) | 170226 (1) | 170224 (1) |
| 10 | 1.75" VINYL COATED STRAP | 600107 (2) | 600107 (2) | SEE 7A | 600107 (1) | 600107 (1) | SEE 7A |
| 11 | NEOPRENE TAPE 1/8" X 1" X 2" | 28003 (4) | 28003 (4) | 28003 (4) | 28003 (2) | 28003 (2) | 28003 (2) |
| 12 | EDGE GUARD (CUT TO LENGTH) | 114012 | 114012 | 114012 | 114012 | 114012 | 114012 |
| NOT SHOWN * | 13 ULT MAIN HARNESS (REFERENCE ONLY) | 350092 | 350092 | 350092 | 350093 | 350093 | 350093 |
| NOT SHOWN | 14 ENCLOSURE LOW STAGE HARNESS | 350108 | 350108 | 350108 | 350108 | 350108 | 350108 |
| NOT SHOWN | 15 ENCLOSURE HIGH STAGE HARNESS | 350107 | 350107 | 350107 | N/A | N/A | N/A |
| NOT SHOWN | 16 NOMEX COVER | 250138 | 250138 | 250138 | 250138 | 250138 | 250138 |
| NOT SHOWN | 17 ESD WARNING LABEL | 220555 (2) | 220555 (2) | 220555 (2) | 220555 (2) | 220555 (2) | 220555 (2) |
| NOT SHOWN, SEE NOTE 3 | 18 IDENTIFICATION LABEL | 823050 (2) | 823060 (2) | 812060 (2) | 423050 (2) | 423060 (2) | 412060 (2) |

* THE ULT MAIN HARNESS IS LISTED FOR INFORMATION ONLY. IT IS NOT PART OF THIS ASSEMBLY.

Upright Freezer Start Component
Enclosure Assembly

120230-01-2-D Rev 10
Page 2 of 2

HIGH TEMP STAGE

REFRIGERATION

HIGH TEMPERATURE STAGE REFRIGERANT:
 UPRIGHTS
 13.0 CU.FT. UNITS: R-404A 18.5 OZ. (525gr) 1/2 OZ (14gr)
 17.0 CU.FT. UNITS: R-404A 22 OZ. (624gr) 1/2 OZ (14gr)
 23.0 CU.FT. UNITS: R-404A 22 OZ. (624gr) 1/2 OZ (14gr)
 HIGH TEMPERATURE STAGE OIL: MOBILE EAL ARCTIC 22CC POLYOL ESTER OIL
 COMPRESSOR, 40 OZ (1183ml)
 CHESTS
 12.7 CU.FT. UNITS: R-404A 19 OZ. (538gr) 1/2 OZ (14gr)
 17.0 CU.FT. UNITS: R-404A 21 OZ. (595gr) 1/2 OZ (14gr)
 20.0 CU.FT. UNITS: R-404A 23 OZ. (652gr) 1/2 OZ (14gr)
 HIGH TEMPERATURE STAGE OIL: MOBILE EAL ARCTIC 22CC POLYOL ESTER OIL
 COMPRESSOR, 40 OZ (1183ml)
 OIL SEPARATOR: 15 OZ (444ml)

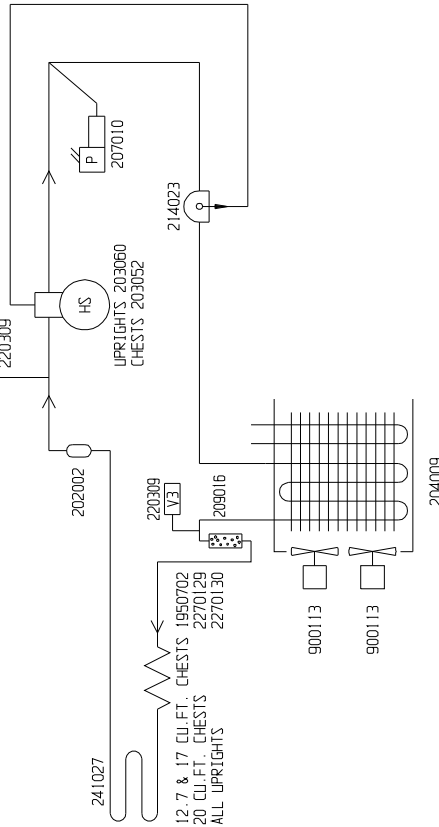

1. COMMON TO: 5722, 8800, 8813, 8824, 8838, 13.0 CU.FT. UPRIGHT FREEZERS (120 V)
 5728, 8804, 8817, 8828, 8842, 17.0 CU.FT. UPRIGHT FREEZERS (120 V)
 8809, 8821, 8832, 8848, 23 CU.FT. UPRIGHT FREEZERS (120 V)
 5315, 8728, 8756, 8779, 12.7 CU.FT. CHEST FREEZER (120V)
 5318, 8730, 8757, 8780, 17.0 CU.FT. CHEST FREEZER (120V)
 5321, 8737, 8762, 8785, 20.0 CU.FT. CHEST FREEZER (120V)

THIS DOCUMENT CONTAINS PROPRIETARY INFORMATION AND SUCH INFORMATION IS NOT TO BE DISCLOSED TO OTHERS FOR ANY PURPOSE NOR USED FOR MANUFACTURING PURPOSES WITHOUT WRITTEN PERMISSION FROM THERMO FISHER SCIENTIFIC

ThermoFisher
SCIENTIFIC

BOX 649, MARIETTA, OHIO 45750

| | | | | | | |
|---|---------|----------|-----|-----|-----|-----------------------------------|
| 10 | FR-2761 | 01-14-15 | AJC | SAG | CCS | CHG. 13 UPRIGHT 21 TO 18.5 CHARGE |
| 9 | FR-2761 | 01-07-15 | AJC | SAG | DRP | CHANGED UPRIGHT CHARGES |
| 8 | FR-2694 | 07-10-14 | AJC | KDG | DRP | SPECIFIED OIL SEP. 15 OZ. OF OIL |
| 7 | FR-2673 | 05-04-14 | MAM | KDG | DRP | CHG'D. 214006 OIL SEP. TO 214023 |
| 6 | FR-2499 | 07-30-13 | AJC | SAG | DRP | U.R. COMP. FROM 203056 TO 203060 |
| 5 | FR-2400 | 08-20-12 | AJC | KDG | DRP | U.R. COMP. 203053 TO 203056-REL.8 |
| 4 | FR-2267 | 2/03/12 | JME | KDG | DRP | UPRIGHT OIL FROM 24 OZ. TO 22 OZ. |
| 3 | FR-2267 | 01/16/12 | JME | SAG | DRP | CHEST OIL FROM 24 OZ. TO 40 OZ. |
| 2 | FR-2267 | 11/07/11 | JME | SAG | DRP | COMPRESSOR CHANGE/RELEASE 7 |
| 1 | FR-2202 | 08/02/11 | AJC | SAG | DRP | ADDED CAP TUBE 2270120 |
| 0 | FR-2202 | 05/09/11 | SFS | SAG | DRP | RELEASED FOR PRODUCTION/RELEASE 6 |
| REV ECR NO./DATE (BY CAD/APP) DESCRIPTION OF REVISION | | | | | | |
| DATE 05/09/11 DWN SAG CAD SAG APPD DRP SCALE NONE | | | | | | |
| CUSTOMER | | | | | | |
| JOB TITLE -40°C ULTRA-LOW TEMPERATURE FREEZERS, 120V | | | | | | |
| DWG TITLE REFRIGERATION SCHEMATIC | | | | | | |
| LOCATION JOB NUMBER DRAWING NUMBER | | | | | | |
| FREEZERS 8800-90-0-B | | | | | | |
| 9999183 | | | | | | |

HIGH TEMP STAGE

REFRIGERATION

HIGH TEMPERATURE STAGE REFRIGERANT:

- 50 AND 60 HZ UPRIGHTS
- 130 CUFT. UNITS: R-404A 21 OZ. (595gr) ±1/2 OZ (14gr)
- 170 CUFT. UNITS: R-404A 22 OZ. (624gr) ±1/2 OZ (14gr)
- 230 CUFT. UNITS: R-404A 22 OZ. (624gr) ±1/2 OZ (14gr)
- HIGH TEMPERATURE STAGE OIL: MOBILE EAL ARCTIC 22CC POLYOL ESTER OIL COMPRESSOR, 40 OZ (1183ml)
- OIL SEPARATOR, 15 OZ (444 ml)
- CHESTS
- 12.7 CUFT. UNITS: R-404A 19 OZ. (538gr) ±1/2 OZ (14gr)
- 170 CUFT. UNITS: R-404A 21 OZ. (595gr) ±1/2 OZ (14gr)
- 200 CUFT. UNITS: R-404A 23 OZ. (652gr) ±1/2 OZ (14gr)
- HIGH TEMPERATURE STAGE OIL: MOBILE EAL ARCTIC 22CC POLYOL ESTER OIL COMPRESSOR, 40 OZ (1183ml)
- OIL SEPARATOR, 15 OZ (444ml)

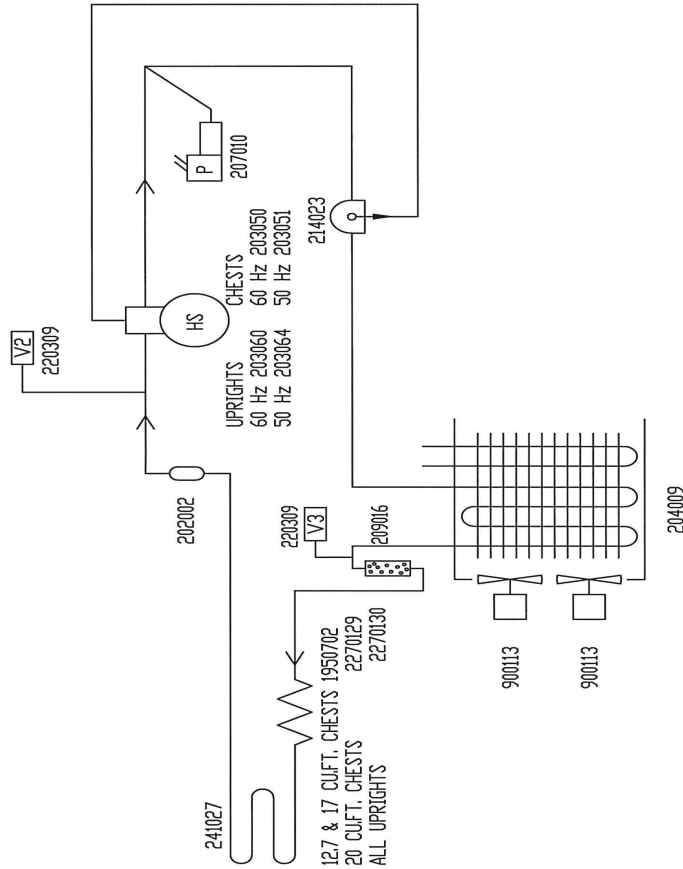

- 1. COMMON TO:
- 7240, DF24040, TS040200, VWR24040, 7240V, DF24040V, HF040200V, TS040240V, VWR24040V, 7240RPT, DF24040RPT, TS040240RPT, 130 CUFT. UPRIGHT FREEZERS (230 V)
- 7280, DF32040, HF040200, TS040200, VWR32040, 7280V, DF32040V, HF040200V, TS040200V, VWR32040V, 7280RPT, DF32040RPT, TS040200RPT, 170 CUFT. UPRIGHT FREEZERS (230 V)
- 7400, DF4040, HF040400, TS040400, VWR4040, 7400RPT, DF4040RPT, TS04040RPT, 230 CUFT. UPRIGHT FREEZERS (230 V)
- 7330, HF03500, TS03500, UL1150-IP-V, 7130V, HF03500V, TS03500V, UL1150-IP-EP, 12.7 CUFT CHEST FREEZER (230V)
- 7170, HF07500, TS07500, UL1750-IP-V, 7170V, HF07500V, TS07500V, UL1750-IP-EP, 170 CUFT CHEST FREEZER (230V)
- 7200, HF2000, TS2000, UL1200-IP-V, 7200V, HF2000V, TS2000V, UL1200-IP-EP, 200 CUFT CHEST FREEZER (230V)

THIS DOCUMENT CONTAINS PROPRIETARY INFORMATION AND SUCH INFORMATION IS NOT TO BE DISCLOSED TO OTHERS FOR ANY PURPOSE NOR USED FOR MANUFACTURING PURPOSES WITHOUT WRITTEN PERMISSION FROM THERMO FISHER SCIENTIFIC

ThermoFisher
SCIENTIFIC

BOX 649, MARIETTA, OHIO 45750

| 11 | 41795 | 12-13-17 | KMB TFI | Y _{amb} | ADDED OPD MODELS IN 'COMMON TO' DETAILS |
|--|---------------|------------|--|------------------|--|
| 10 | 40483 | 10-27-17 | KMB TFI <td>Y_{amb}</td> <td>ADDED OIL SEPARATOR NOTE AND UPDATED 'COMMON TO' DETAILS</td> | Y _{amb} | ADDED OIL SEPARATOR NOTE AND UPDATED 'COMMON TO' DETAILS |
| 9 | FR-2761 | 01-07-15 | AJC SAG | DRP | CHANGED CHARGE/ADDED 5713 & 5726 |
| 8 | FR-2694 | 07-10-14 | AJC KDG | DRP | SPECIFIED OIL SEP. 15 OZ. OF OIL |
| 7 | FR-2673 | 06-04-14 | MAM KDG | DRP | CHG'D. 214006 OIL SEP. TO 214023 |
| 6 | FR-2499 | 07-30-13 | AJC SAG | DRP | CHANGED UR. COMPRESSORS & CHARGE |
| 5 | FR-2400 | 08-20-12 | AJC KDG | DRP | UR COMP203054,55 TO 203057,58-REL8 |
| 4 | FR-2267 | 2/02/12 | JVESAG | DRP | UPRIGHT OIL FROM 24 OZ. TO 22 OZ. |
| 3 | FR-2267 | 01/16/12 | JVESAG | DRP | CHEST OIL FROM 24 OZ. TO 40 OZ. |
| 2 | FR-2267 | 11/07/11 | JVESAG | DRP | COMPRESSOR CHANGE/RELEASE 7 |
| 1 | FR-2202 | 08/02/11 | AJC SAG | DRP | ADDED CAP TUBE 227020 |
| 0 | FR-2202 | 05/09/11 | SRS SAG | LDN | RELEASED FOR PRODUCTION/RELEASE 6 |
| REV | ECR NO. | DATE | BY | CAD APP'D | DESCRIPTION OF REVISION |
| | DATE 05/09/11 | DWN SAG | CAD SAG | APP'D LDN | SCALE NONE |
| CUSTOMER | | | | | |
| JOB TITLE -40°C ULTRA-LOW TEMPERATURE FREEZERS, 230V | | | | | |
| DWG TITLE REFRIGERATION SCHEMATIC | | | | | |
| LOCATION | | JOB NUMBER | | DRAWING NUMBER | |
| FREEZERS | | | | 8801-90-0-B | |

POWER CONNECTION
120V, 1Ø, 2V, 60HZ, 10.0 FLA
(OPERATING RANGE 108-132V)

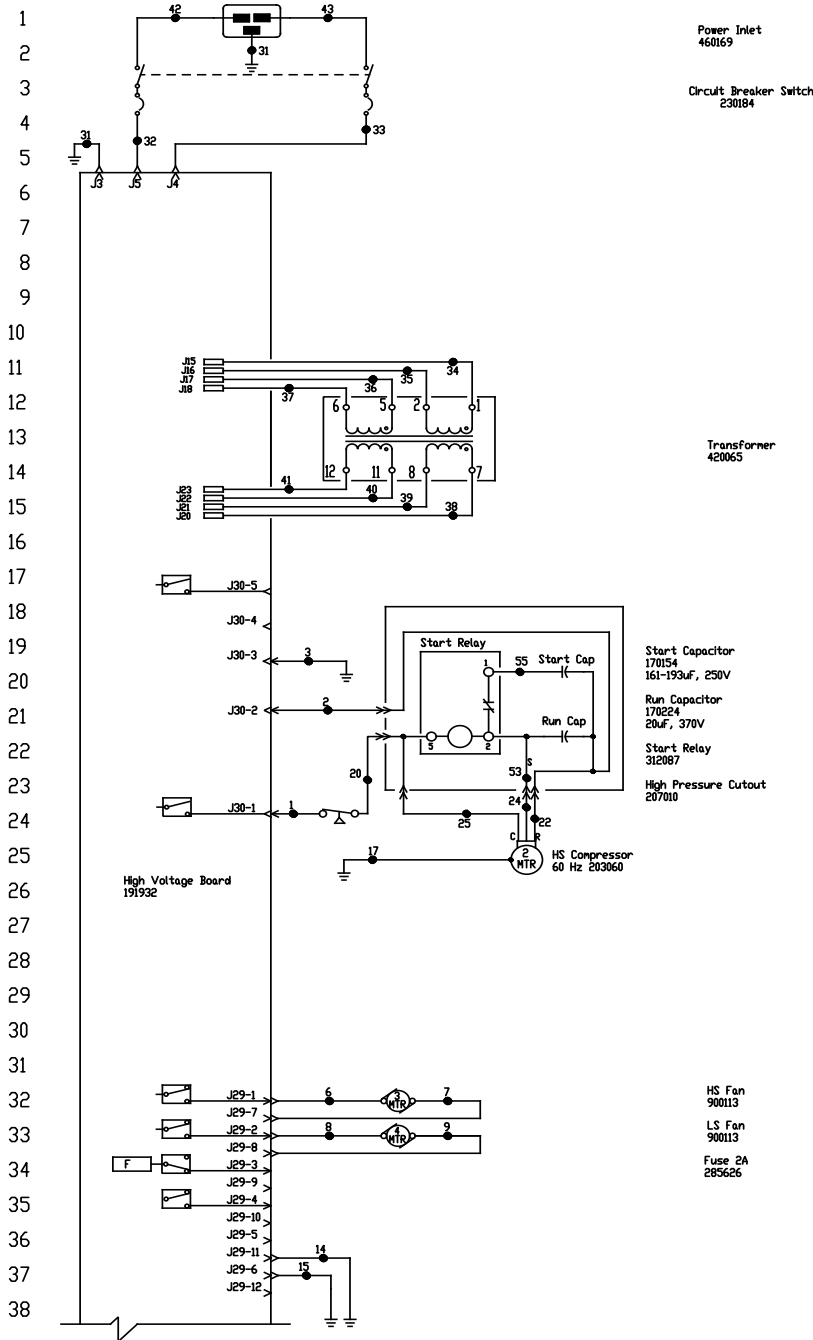

Electrical Schematic
Model:
120V, 60Hz, -40°C
ULT Upright Freezers

8800-70-1-0 REV 11
Page 1 of 3

Section 9
Electrical Schematics

39
40
41
42
43
44
45
46
47
48
49
50
51
52
53
54
55
56
57
58
59
60
61
62
63
64
65
66
67
68
69
70
71
72
73
74
75
76

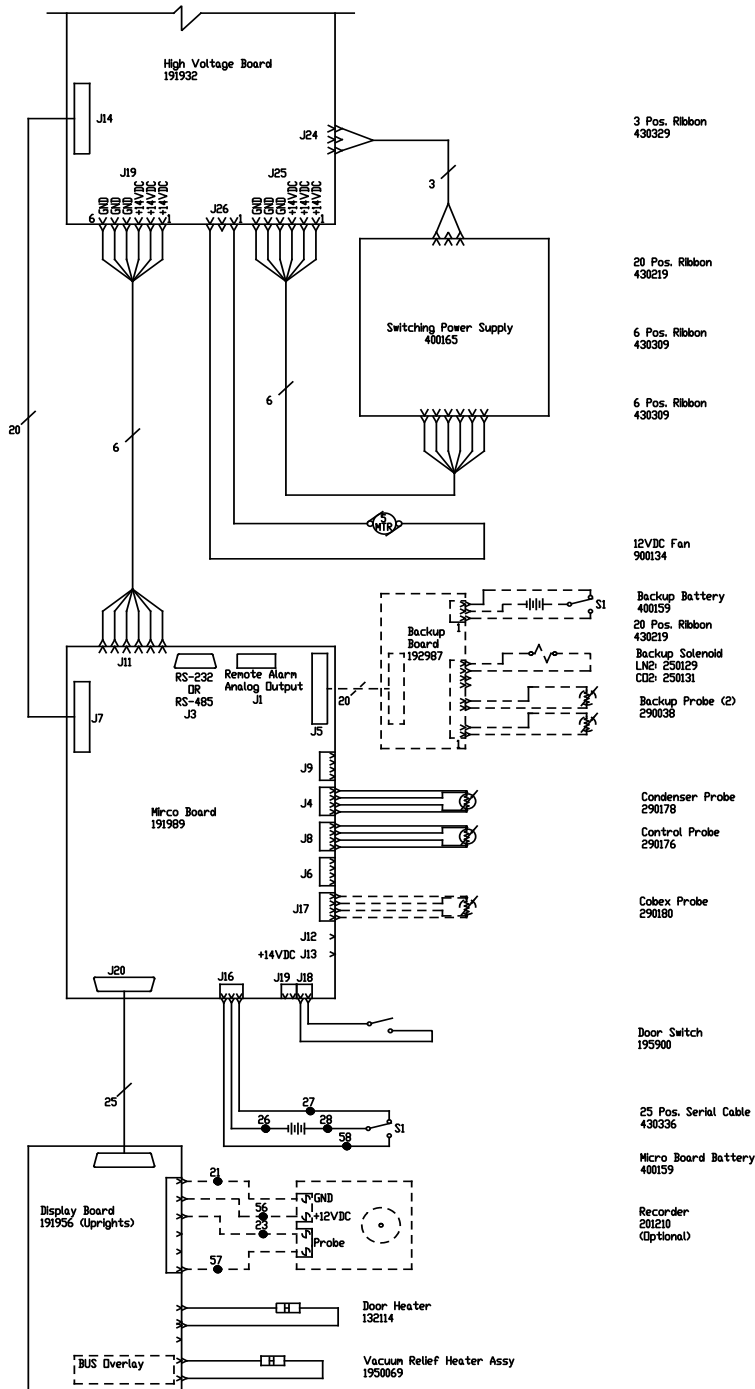

Electrical Schematic
Model:
120V, 60Hz, -40°C
ULT Upright Freezers

8800-70-1-0 REV 11
Page 2 of 3

77
78
79
80
81
82
83
84
85
86
87
88
89
90
91
92
93
94
95
96
97
98
99
100
101
102
103
104
105
106
107

| WIRE # | COLOR | GAUGE | WIRE # | COLOR | GAUGE |
|--------|---------|-------|--------|---------|-------|
| 1 | BLK | 14 | 29 | - | - |
| 2 | RED | 14 | 30 | - | - |
| 3 | GRN/YEL | 14 | 31 | GRN/YEL | 14 |
| 4 | | | 32 | BLK | 14 |
| 5 | | | 33 | BLU | 14 |
| 6 | BLK | 18 | 34 | BLK | 14 |
| 7 | BLK | 18 | 35 | BLU | 14 |
| 8 | BLK | 18 | 36 | BLU | 14 |
| 9 | BLK | 18 | 37 | BLU | 14 |
| 10 | | | 38 | BLK | 14 |
| 11 | | | 39 | BLU | 14 |
| 12 | | | 40 | BLK | 14 |
| 13 | | | 41 | BLU | 14 |
| 14 | GRN/YEL | 18 | 42 | BLK | 14 |
| 15 | GRN/YEL | 18 | 43 | BLU | 14 |
| 16 | | | 44 | - | - |
| 17 | GRN/YEL | 14 | 45 | - | - |
| 18 | | | 46 | - | - |
| 19 | | | 47 | - | - |
| 20 | BLK | 14 | 48 | - | - |
| 21 | BLK | 18 | 49 | - | - |
| 22 | RED | 18 | 50 | - | - |
| 23 | BLK | 18 | 51 | - | - |
| 24 | YEL | 14 | 52 | - | - |
| 25 | BLK | 14 | 53 | YEL | 14 |
| 26 | BLK | 18 | 54 | - | - |
| 27 | BLK | 18 | 55 | BLU | 14 |
| 28 | RED | 18 | 56 | RED | 18 |
| | | | 57 | RED | 18 |
| | | | 58 | WHT | 18 |

MODELS:

13 CUFT.(120V) - 7240A, DXF24040A, HFU40240BA, TSD40240A
 17 CUFT.(120V) - 7320A, DXF32040A, HFU40320BA, TSD40320A
 23 CUFT.(120V) - 7400A, DXF40040A, HFU40400BA, TSD40400A

RS-232 SPECIFICATION

BAUD = 1200
 PARITY = N
 BITS = 8
 STOP BITS = 2

REMOTE CONTACTS/ANALOG OUTPUT
 PIN# 1 Analog Output +
 PIN# 2 Analog Output -
 PIN# 3 Not Connected
 PIN# 4 Not Connected
 PIN# 5 Normally Closed
 PIN# 6 Common
 PIN# 7 Normally Open

RS-232 PORT
 PIN# 2 TXD
 PIN# 3 RXD
 PIN# 5 GND

CONTACT RATING: 1A @ 30V
 CONTACTS IN ALARM STATE

SW1 Settings for Analog Output

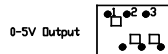
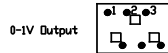
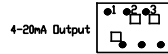

SW2 Settings for Communication Output

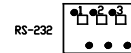
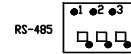

SW3 SETTINGS

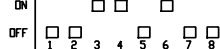

1. Schematic represents single models.
2. Door switches shown in open position.
3. Battery switch shown in the OFF position.
4. Circuit breaker switch shown in OFF position.
5. Options and accessories shown in dashed lines.

| REV | ECN NO. | DATE | BY | CAD | APPD | DESCRIPTION OF REVISION |
|-----|---------|----------|-----|-----|------|---|
| 11 | 41795 | 12-14-17 | KQB | TFI | | UPDATED "MODELS" DETAILS |
| 10 | FR-3006 | 08-14-17 | KB | KDG | KHB | 191987 BACKUP BOARD TO 192987 |
| 9 | FR-2881 | 06-15-16 | KHB | SAG | DRP | 32887 WAS 300421 |
| 8 | FR-2781 | 04-02-15 | KB | KDG | DRP | MD 132114 & 1950659 HTR 700 STYLE DOOR TO 900 |
| 7 | 31856 | 01-27-15 | GLS | SAG | DRP | WIRE #2 FROM ILLU TO REJAS BUILT CHANGES |
| 6 | FR-2499 | 07-30-13 | AJC | SAG | DRP | CHANGED COMPRESSOR & START COMPONENTS |
| 5 | FR-2409 | 09-24-12 | AJC | KDG | DRP | REL6, LHM 19090 NICRO ILLU TO HIGH ILLU 19099 |
| 4 | FR-2386 | 08-29-12 | AJC | KDG | DRP | REVISED OPERATING RANGE FROM 100-130V |
| 3 | FR-2329 | 03/05/12 | AJC | SAG | DRP | ADDED HIGH PRESSURE CUTOFF |
| 2 | FR-2267 | 02/23/12 | JME | SAG | DRP | REPLACED PTCR WITH HARD START COMP |
| 1 | FR-2267 | 11/29/11 | JME | SAG | LHM | COMPRESSOR CHANGE / RELEASE 7 |
| 0 | FR-2202 | 04/29/11 | SRS | SAG | LHM | RELEASED FOR PRODUCTION / RELEASE 6 |

Electrical Schematic
 Model:
 120V, 60Hz, -40°C
 ULT Upright Freezers



THIS DOCUMENT CONTAINS PROPRIETARY INFORMATION AND SUCH INFORMATION IS NOT TO BE DISCLOSED TO OTHERS FOR ANY PURPOSE NOR USED FOR MANUFACTURING PURPOSES WITHOUT WRITTEN PERMISSION FROM THERMO FISHER SCIENTIFIC.

ThermoFisher SCIENTIFIC
 BOX 649, MARIETTA, OHIO 45750

| | | |
|---|-----------------|-------------|
| MODEL/PART NAME: LHM-ENB, -40° UPRIGHT FREEZERS, 120V, 60Hz | DATE: 10-10-10 | SCALE: NONE |
| DWG TITLE: UNIT SCHEMATIC | | |
| MATERIALS: | | |
| PANT COLOR: | | |
| TOLERANCE UNLESS OTHERWISE SPECIFIED: | DRAWING NUMBER: | SIZE: |
| ANGLES: DECIMALS | 8800-70-1 | D |

8800-70-1-0 REV 11
 Page 3 of 3

Section 9
Electrical Schematics

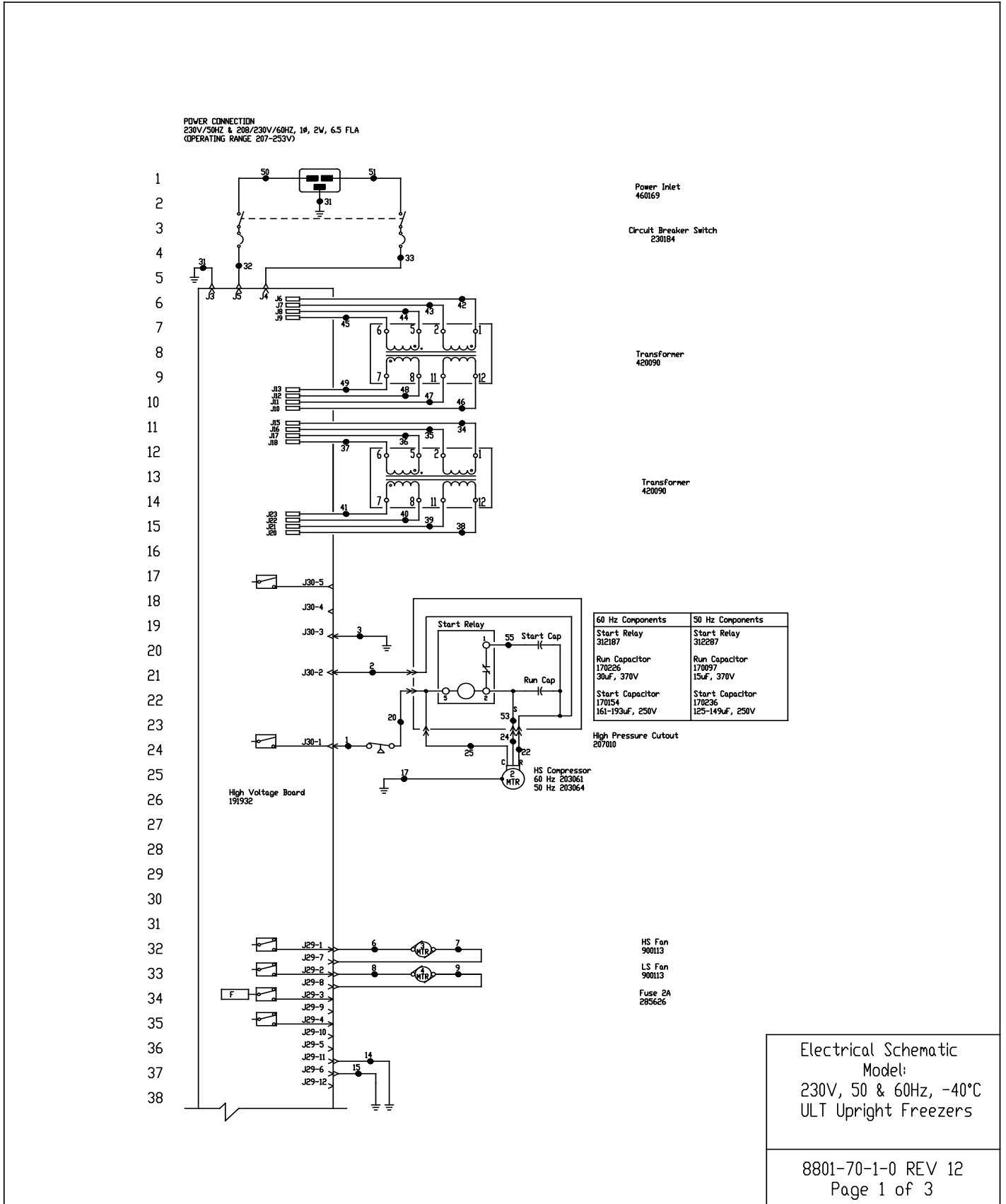

Section 9
Electrical Schematics

77
78
79
80
81
82
83
84
85
86
87
88
89
90
91
92
93
94
95
96
97
98
99
100
101
102
103
104
105
106
107

| VIRE # | COLOR | GAUGE | VIRE # | COLOR | GAUGE |
|--------|---------|-------|--------|---------|-------|
| 1 | BLK | 14 | 29 | - | - |
| 2 | RED | 14 | 30 | - | - |
| 3 | GRN/YEL | 14 | 31 | GRN/YEL | 14 |
| 4 | | | 32 | BLK | 14 |
| 5 | | | 33 | BLU | 14 |
| 6 | BLK | 18 | 34 | BLK | 14 |
| 7 | BLK | 18 | 35 | BLU | 14 |
| 8 | BLK | 18 | 36 | BLK | 14 |
| 9 | BLK | 18 | 37 | BLU | 14 |
| 10 | | | 38 | BLK | 14 |
| 11 | | | 39 | BLU | 14 |
| 12 | | | 40 | BLK | 14 |
| 13 | | | 41 | BLU | 14 |
| 14 | GRN/YEL | 18 | 42 | BLK | 14 |
| 15 | GRN/YEL | 18 | 43 | BLU | 14 |
| 16 | | | 44 | BLK | 14 |
| 17 | GRN/YEL | 14 | 45 | BLU | 14 |
| 18 | | | 46 | BLK | 14 |
| 19 | | | 47 | BLU | 14 |
| 20 | BLK | 14 | 48 | BLK | 14 |
| 21 | BLK | 18 | 49 | BLU | 14 |
| 22 | RED | 18 | 50 | BLK | 14 |
| 23 | BLK | 18 | 51 | BLU | 14 |
| 24 | YEL | 14 | 52 | - | - |
| 25 | BLK | 14 | 53 | YEL | 14 |
| 26 | BLK | 18 | 54 | - | - |
| 27 | BLK | 18 | 55 | BLU | 14 |
| 28 | RED | 18 | 56 | RED | 18 |
| | | | 57 | RED | 18 |
| | | | 58 | WHT | 18 |

MODELS:
 13 CLF.T.(230V) - 7240D, DXF24040D, HFU40240BD, TSD40240D, 7240V, DXF24040V, HFU40240BV, TSD40240V, 7240GPD, DXF24040GPD, TSD40240GPD
 17 CLF.T.(230V) - 7320D, DXF32040D, HFU40320BD, TSD40320D, 7320V, DXF32040V, HFU40320BV, TSD40320V, 7320GPD, DXF32040GPD, TSD40320GPD
 23 CLF.T.(230V) - 7400D, DXF40040D, HFU40400BD, TSD40400D, 7400V, DXF40040V, HFU40400BV, TSD40400V, 7400GPD, DXF40040GPD, TSD40400GPD

RS-232 SPECIFICATION

BAUD = 1200
 PARITY = N
 BITS = 8
 STOP BITS = 2

REMOTE CONTACTS/ANALOG OUTPUT
 PIN# 1 Analog Output +
 PIN# 2 Analog Output -
 PIN# 3 Not Connected
 PIN# 4 Not Connected
 PIN# 5 Normally Closed
 PIN# 6 Common
 PIN# 7 Normally Open

RS-232 PORT
 PIN# 2 TXD
 PIN# 3 RXD
 PIN# 5 GND

CONTACT RATING 1A @ 30V
 CONTACTS IN ALARM STATE

SW1 Settings for Analog Output

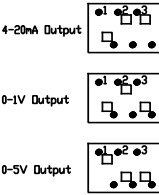

SW2 Settings for Communication Output

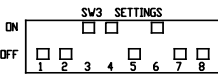
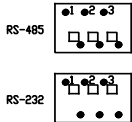

- Schematic represents upright models.
- Door switch shown in open position.
- Battery switch shown in the OFF position.
- Disconnect breaker switch shown in OFF position.
- Options and accessories shown in dashed lines.

| REV | ECN | NO. | DATE | BY | CAD | APPD | DESCRIPTION OF REVISION |
|-----|---------|----------|------|-----|-----|------|--|
| 12 | 41795 | 12-13-17 | KMB | TFT | | | UPDATED "MODELS" DETAILS |
| 11 | FR-3086 | 08-14-17 | KB | KGB | KMB | | 192907 BACKUP BOMMS TO 192907 |
| 10 | FR-2888 | 06-15-16 | KMB | SAG | DRP | | 38287 HAS 38042, 38287 HAS 38045 |
| 9 | FR-2843 | 04-05-16 | KB | SAG | DRP | | 23004 HAS 23078 |
| 8 | FR-2780 | 04-02-15 | KB | KGB | DRP | | ADD 13204 & 192869 HIR 700 STYLE BODR TO 900 |
| 7 | 31856 | 01-27-15 | GLS | SAG | DRP | | WIRE RE FROM BLU TO REDAS BUILT CORRECTIONS |
| 6 | FR-2499 | 07-30-13 | AJC | SAG | DRP | | CHANGED COMPRESSORS & START COMPONENTS |
| 5 | FR-2499 | 09-24-12 | AJC | KGB | DRP | | RELA, LOW 19288 MICRO BLTD HIGH END 19289 |
| 4 | FR-2386 | 08-29-12 | AJC | KGB | DRP | | REVISED OPERATING RANGE FROM 290-240V |
| 3 | FR-2329 | 03/08/12 | AJC | SAG | DRP | | ADDED HIGH PRESSURE OUTPUT |
| 2 | FR-2267 | 02/23/12 | JAE | SAG | DRP | | REPLACED PTCR WITH HARD START COMP. |
| 1 | FR-2267 | 11/28/11 | JAE | SAG | DRP | | COMPRESSOR CHANGE / RELEASE 7 |
| 0 | FR-2262 | 04/29/11 | SRS | SAG | LDN | | RELEASED FOR PRODUCTION / RELEASE 6 |

Electrical Schematic
 Model:
 230V, 50 & 60Hz, -40°C
 ULT Upright Freezers



THIS DOCUMENT CONTAINS PROPRIETARY INFORMATION AND SUCH INFORMATION IS NOT TO BE DISCLOSED TO OTHERS FOR ANY PURPOSE NOR USED FOR MANUFACTURING PURPOSES WITHOUT WRITTEN PERMISSION FROM THERMO FISHER SCIENTIFIC

ThermoFisher SCIENTIFIC
 BOX 649, MARIETTA, OHIO 45750

| | |
|---------------------------------------|--|
| MODEL/PART NAME | LDN-END, -40° UPRIGHT FREEZERS, 230V, 50 & 60 Hz |
| DWG TITLE | UNIT SCHEMATIC |
| DWN HCE | CAD: KGB APPD: LDN DATE: 10-10-10 SCALE: NONE |
| MATERIAL: | |
| PAINTE COLOR: | |
| TOLERANCE UNLESS OTHERWISE SPECIFIED: | |
| ANGLES: | |
| DRAWING NUMBER | 8801-70-1 |
| SIZE | D |

8801-70-1-0 REV 12
 Page 3 of 3

THERMO FISHER SCIENTIFIC FREEZER WARRANTY

The Warranty Period starts two weeks from the date your equipment is shipped from our facility. This allows for shipping time so the warranty will go into effect at approximately the same time your equipment is delivered. The warranty protection extends to any subsequent owner during the warranty period.

During the first two years of the warranty period, component parts proven to be non-conforming in materials or workmanship will be repaired or replaced at Thermo's expense, labor included. The ULT Freezers include an additional two year warranty on the compressors, parts only, F.O.B. factory. Installation and calibration is not covered by this warranty agreement. The Technical Services Department must be contacted for warranty determination and direction prior to any work being performed. Expendable items, i.e., glass, filters, pilot lights, light bulbs and door gaskets are excluded from this warranty.

Replacement or repair of component parts or equipment under this warranty shall not extend the warranty to either the equipment or to the component part beyond the original two year warranty period. The Technical Services Department must give prior approval for the return of any components or equipment.

THIS WARRANTY IS EXCLUSIVE AND IN LIEU OF ALL OTHER WARRANTIES, WHETHER WRITTEN, ORAL, OR IMPLIED. NO WARRANTIES OF MERCHANTABILITY OR FITNESS FOR A PARTICULAR PURPOSE SHALL APPLY. Thermo shall not be liable for any indirect or consequential damages including, without limitation, damages relating to lost profits or loss of products.

Your local Thermo Sales Office is ready to help with comprehensive site preparation information before your equipment arrives. Printed instruction manuals carefully detail equipment installation with operation, preventive maintenance and maintenance information on an included CD.

If equipment service is required, please call your Technical Services Department at 1-800-438-4851 (USA and Canada) or 1-740-373-4763. We're ready to answer your questions on equipment warranty, operation, maintenance, service, and special applications. Outside the USA, contact your local Thermo Scientific office or distributor for warranty information.



Rev. 10/14

THERMO FISHER SCIENTIFIC FREEZER INTERNATIONAL DEALER WARRANTY

The Warranty Period starts two months from the date your equipment is shipped from our facility. This allows for shipping time so the warranty will go into effect at approximately the same time your equipment is delivered. The warranty protection extends to any subsequent owner during the warranty period. Dealers who stock our equipment are allowed an additional four months for delivery and installation, providing the warranty is registered online.

During the first two years of the warranty period, component parts proven to be non-conforming in materials or workmanship will be repaired or replaced at Thermo's expense, labor excluded. The ULT Freezers include an additional two year warranty on the compressors, parts only, F.O.B. factory. Installation and calibration is not covered by this warranty agreement. The Technical Services Department must be contacted for warranty determination and direction prior to any work being performed. Expendable items, i.e., glass, filters, pilot lights, light bulbs and door gaskets are excluded from this warranty.

Replacement or repair of component parts or equipment under this warranty shall not extend the warranty to either the equipment or to the component part beyond the original two year warranty period. The Technical Services Department must give prior approval for the return of any components or equipment.

THIS WARRANTY IS EXCLUSIVE AND IN LIEU OF ALL OTHER WARRANTIES, WHETHER WRITTEN, ORAL, OR IMPLIED. NO WARRANTIES OF MERCHANTABILITY OR FITNESS FOR A PARTICULAR PURPOSE SHALL APPLY. Thermo shall not be liable for any indirect or consequential damages including, without limitation, damages relating to lost profits or loss of products.

Your local Thermo Sales Office is ready to help with comprehensive site preparation information before your equipment arrives. Printed instruction manuals carefully detail equipment installation with operation, preventive maintenance and maintenance information on an included CD.

If equipment service is required, please call your local distributor or the Technical Services Department at 1-800-438-4851 (USA and Canada) or 1-740-373-4763. We're ready to answer your questions on equipment warranty, operation, maintenance, service, and special applications. Outside the USA, contact your local Thermo Scientific office or distributor for warranty information.



Rev. 10/14

Appendix A Handling Liquid Nitrogen

Warning Contact of liquid nitrogen or cold gas with skin or eyes may cause serious freezing (frostbite) injury. ▲

Handle liquid nitrogen carefully.

The extremely low temperature can freeze human flesh very rapidly. When spilled on a surface the liquid tends to cover it completely and intimately, cooling a large area. The gas issuing from the liquid is also extremely cold. Delicate tissue, such as that of the eyes, can be damaged by an exposure to the cold gas which would be too brief to affect the skin of the hands or face.

Never allow any unprotected part of your body to touch objects cooled by liquid nitrogen.

Such objects may stick fast to the skin and tear the flesh when you attempt to free yourself. Use tongs to withdraw objects immersed in the liquid, and handle the object carefully.

Wear protective clothing.

Protect your eyes with a face shield or safety goggles (safety glasses without side shields do not give adequate protection). Always wear gloves when handling anything that is, or may have been, in immediate contact with liquid nitrogen. Insulated gloves are recommended, but heavy leather gloves may also be used. The gloves should fit loosely, so that they can be thrown off quickly if liquid should splash into them. When handling liquid in open containers, it is advisable to wear high-top shoes. Trousers (which should be cuffless if possible) should be worn outside the shoes.

The safe handling and use of liquid nitrogen in cryogenic refrigerators and dewar flasks is largely a matter of knowing the potential hazards and using common-sense procedures based on that knowledge. There are two important properties of liquid nitrogen that present potential hazards:

1. It is extremely cold. At atmospheric pressure, liquid nitrogen boils at -320°F (-196°C).
2. Very small amounts of liquid vaporize into large amounts of gas. One liter of liquid nitrogen becomes 24.6 cu. ft. (700l) of gas.

The safety precautions in this booklet must be followed to avoid potential injury or damage which could result from these two characteristics. Do not attempt to handle liquid nitrogen until you read and fully understand the potential hazards, their consequences, and the related safety precautions. Keep this booklet handy for ready reference and review.

Note Because argon is an inert gas whose physical properties are very similar to those of nitrogen, the precautions and safe practices for the handling and use of liquid argon are the same as those for liquid nitrogen. ▲

Use only containers designed for low temperature liquids.

Cryogenic containers are specifically designed and made of materials that can withstand the rapid changes and extreme temperature differences encountered in working with liquid nitrogen. Even these special containers should be filled SLOWLY to minimize the internal stresses that occur when any material is cooled. Excessive internal stresses can damage the container.

Do not cover or plug the entrance opening of any liquid nitrogen refrigerator or dewar. Do not use any stopper or other device that would interfere with venting of gas.

These cryogenic liquid containers are generally designed to operate with little or no internal pressure.

Inadequate venting can result in excessive gas pressure which could damage or burst the container. Use only the loose-fitting necktube core supplied or one of the approved accessories for closing the necktube. Check the unit periodically to be sure that venting is not restricted by accumulated ice or frost.

Use proper transfer equipment.

Use a phase separator or special filling funnel to prevent splashing and spilling when transferring liquid nitrogen into or from a dewar or refrigerator. The top of the funnel should be partly covered to reduce splashing. Use only small, easily-handled dewars for pouring liquid. For the larger, heavier containers, use a cryogenic liquid withdrawal device to transfer liquid from one container to another. Be sure to follow instructions supplied with the withdrawal device. When liquid cylinders or other large storage containers are used for filling, follow the instructions supplied with those units and their accessories.

Do not overfill containers.

Filling above the bottom of the necktube (or specified maximum level) can result in overflow and spillage of liquid when the necktube core or cover is placed in the opening.

Never use hollow rods or tubes as dipsticks.

When a warm tube is inserted into liquid nitrogen, liquid will spout from the top of the tube due to gasification and rapid expansion of liquid inside the tube.

Warning Nitrogen Gas Can Cause Suffocation Without Warning! ▲

Store and use liquid nitrogen only in a well-ventilated place.

As the liquid evaporates, the resulting gas tends to displace the normal air from the area. In closed areas, excessive amounts of nitrogen gas reduce the concentration of oxygen and can result in asphyxiation. Because nitrogen gas is colorless, odorless and tasteless, it cannot be detected by the human senses and will be breathed as if it were air. Breathing an atmosphere that contains less than 18% oxygen can cause dizziness and quickly result in unconsciousness and death.

Note The cloudy vapor that appears when liquid nitrogen is exposed to the air is condensed moisture; not the gas itself. The issuing gas is invisible. ▲

Never dispose of liquid nitrogen in confined areas or places where others may enter.

Disposal of liquid nitrogen should be done outdoors in a safe place. Pour the liquid slowly on gravel or bare earth where it can evaporate without causing damage. Do not pour the liquid on pavement.

Appendix B Handling Liquid CO₂

Warning High concentrations of CO₂ gas can cause asphyxiation! OSHA Standards specify that employee exposure to carbon dioxide in any eight-hour shift of a 40-hour work week shall not exceed the eight-hour time weighted average of 5000 PPM (0.5% CO₂). The short term exposure limit for 15 minutes or less is 30,000 PPM (3% CO₂). Carbon dioxide monitors are recommended for confined areas where concentrations of carbon dioxide gas can accumulate. ▲

Store and use liquid CO₂ only in a well-ventilated place.

As the liquid evaporates, the resulting gas tends to displace the normal air from the area. In closed areas, excessive amounts of CO₂ gas reduce the concentration of oxygen and can result in asphyxiation. Because CO₂ gas is colorless, odorless and tasteless, it cannot be detected by the human senses and will be breathed as if it were air. Breathing an atmosphere that contains less than 18% oxygen can cause dizziness and quickly result in unconsciousness and death.

Note The cloudy vapor that appears when liquid CO₂ is exposed to the air is condensed moisture; not the gas itself. The issuing gas is invisible. ▲

Never dispose of liquid CO₂ in confined areas or places where others may enter.

Disposal of liquid CO₂ should be done outdoors in a safe place. Pour the liquid slowly on gravel or bare earth where it can evaporate without causing damage. Do not pour the liquid on pavement.

Appendix C First Aid

If a person seems to become dizzy or loses consciousness while working with liquid nitrogen or carbon dioxide, move to a well-ventilated area immediately. If breathing has stopped, apply artificial respiration. If breathing is difficult, give oxygen. Call a physician. Keep warm and at rest.

If exposed to liquid or cold gas, restore tissue to normal body temperature (98.6° F) as rapidly as possible, followed by protection of the injured tissue from further damage and infection. Remove or loosen clothing that may constrict blood circulation to the frozen area. Call a physician. Rapid warming of the affected part is best achieved by using water at 108° F. Under no circumstance should the water be over 112° F, nor should the frozen part be rubbed either before or after rewarming. The patient should neither smoke nor drink alcohol.

thermoscientific.com

© 2014 Thermo Fisher Scientific Inc. All rights reserved. All trademarks are the property of Thermo Fisher Scientific and its subsidiaries. Specifications, terms and pricing are subject to change. Not all products are available in all countries. Please consult your local sales representative for details.

Thermo Fisher Scientific (Asheville) LLC

401 Millcreek Road
Marietta, Ohio 45750
United States

Thermo
S C I E N T I F I C
A Thermo Fisher Scientific Brand