



205 Westwood Ave, Long Branch, NJ 07740
Phone: 866-94 BOARDS (26273) / (732)-222-1511
Fax: (732)-222-7088 | E-mail: sales@touchboards.com

Engineering Spec. of Control Board

REVISION HISTORY

Version	Date	Page	Section	Description
	May 10, 2009			Change RS485 placement

Introduction :

This specification defines the monitor for industrial applications. By using RTD2549T to support a resolution display (1366 X 768 <->1920x1080) ,this monitor offer a various kind of input connector to two kind of video sources (VGA ,DVI & HDMI).

Also with photo sensor that can detect outside environment luminance to compensate Backlight of Panel, also support RS-485 interface that provides a controllability thru PC or Host device .

1. Technical configuration

Item	Description
Input	VGA Video (This port can receive YPbPr signal) DVI Video (This port can receive HDMI/HDCP signal) RS485
Output	RS-485 VGA(loop-through)

2. Features:

Output Timing	WUXGA up to 1920*1080
Support Timing	
VGA/DVI	720 * 400 @ 70 ,85 640 * 480 @ 60 , 66 , 70, 72, 75 800 * 600 @ 56 , 60 , 66, 70, 72, 75 1024 * 768 @60, 66, 70, 72,, 75 1280 * 720 @60 1280 * 768 @60 1360 * 768 @ 60 1152 * 864 @75 1280 * 960@60 1280 * 1024@60, 70 ,75 1600 * 1200@60 1920 * 1080p@60
Panel interface	
Dual LVDS	For 1920*1080 pixel of Panel
Spray Spectrum	For EMI
Sensor	
Photo sensor * 2(MainBoard)+ 3(OptionAE008)	To compensate environments luminance Detect decay of Backlight
Others	
RS-485	Provide connectivity to PC or other host devices and service port.

3. DISPLAY CONTROL BOARD

3.1. GT021

3.1.1. Description of GT021

The GT021 display conversion board is designed to directly convert following signals to specific LCD timing signals, these signals are:

- The analog R.G.B. signals from standard VGA display card,
- TMDS signal from standard DVI display card,

This board is composed of analog and digital (VGA and DVI) Signal

3.1.2. Features of GT021

- Build-in micro-controller to detect display timings and control user interface.
- Using E²PROM to memorize adjusted parameters.
- 8-bit triple-channel 210MHz ADC/PLL
- Single link TMDS receiver support to 165MHz (DVI)
- Using Frame Buffer topology to transfer the display data.
- Supporting up to 59 display modes capacity from VGA to WUXGA.
- Offering color temperature selection function including high, middle, low modes.
- Supporting OSD functions.
- Supporting DDC1/2B functions.
- Auto detection/ Auto calibration
 - Input format detection
 - Compatibility with standard VESA mode and support user-defined mode
 - Smart engine for Phase/ Image Position/ Color Calibration
- Offering Dithering function increases display color up to 16M colors.
- Embedded color processing engine,

3.1.3. I/O and inter-connections

3.1.3 GT021

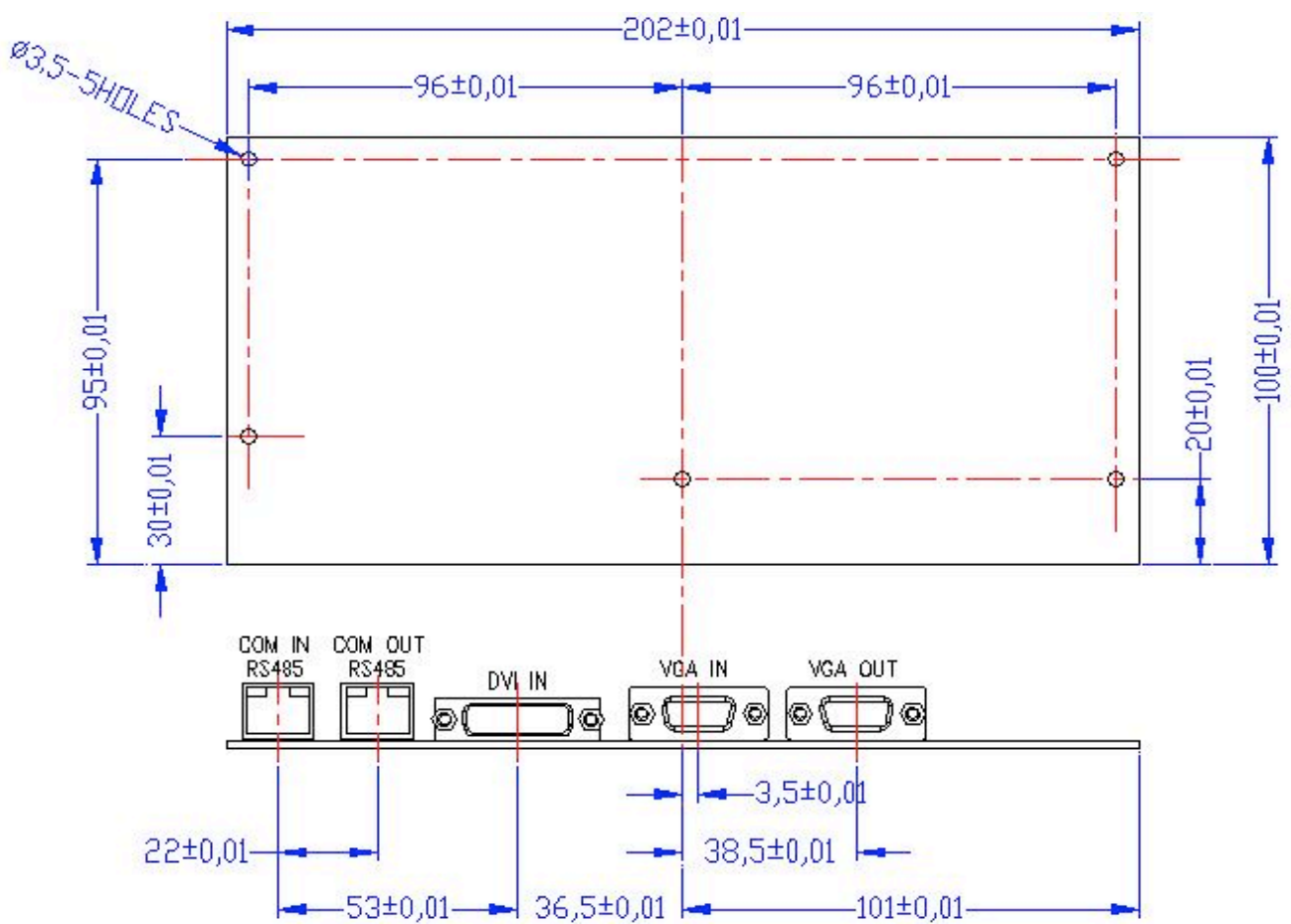

Applications

3.2. Block Diagram

3.2.1. Typical applications for 42" LCD display

AC Power In (100V~240V)

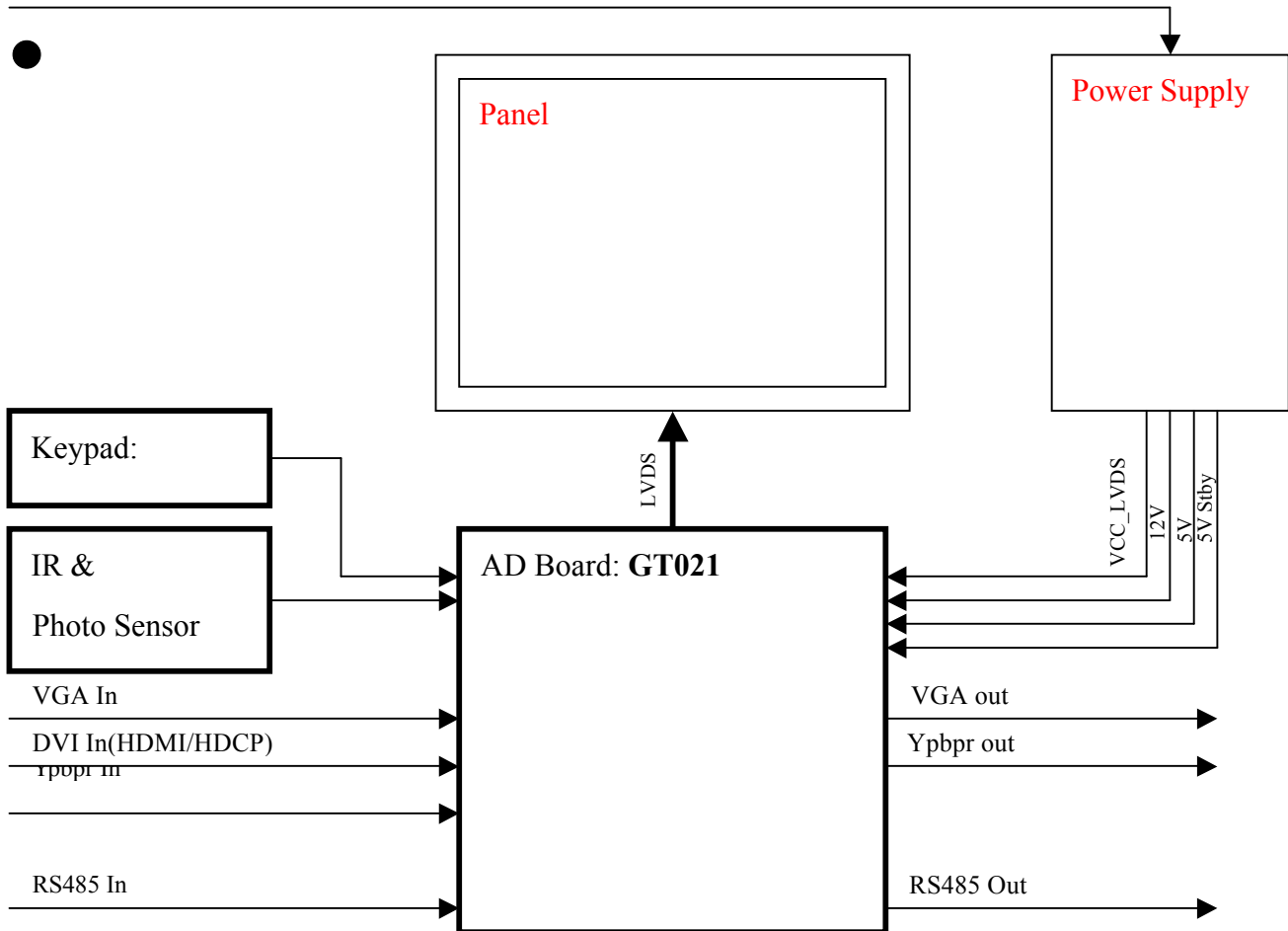

Touchboards

205 Westwood Ave, Long Branch, NJ 07740
Phone: 866-94 BOARDS (26273) / (732)-222-1511
Fax: (732)-222-7088 | E-mail: sales@touchboards.com

● 3.2.3 GT021 Display control board

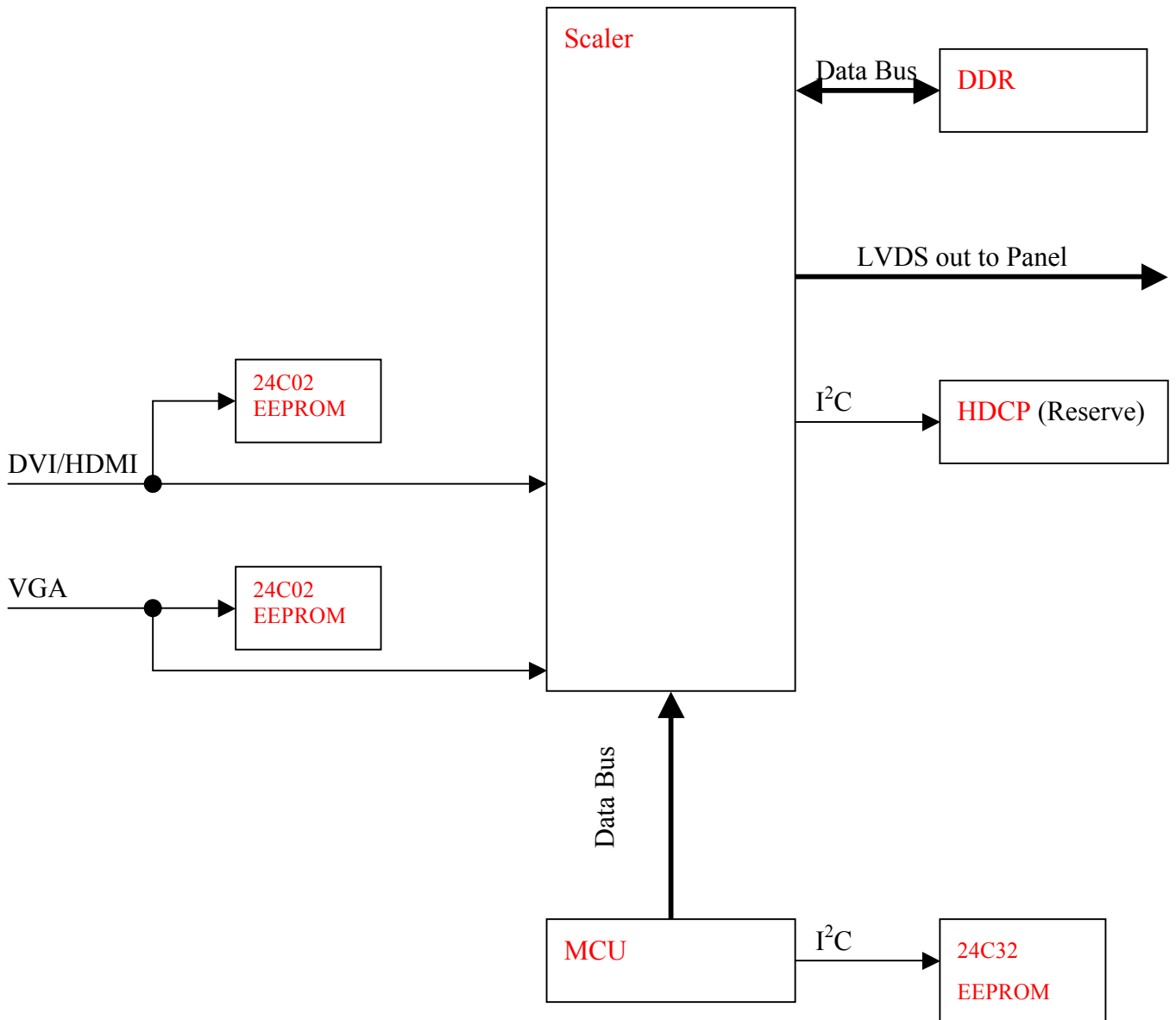

4. Communication (RS485)

4.1 Introduction

This document is the communication protocol between Display and PC Via RS232 -> RS485

4.2 Data format

Data will be transferred serially according to RS232 protocol using the following settings.

Female DB9 DCE pin numbering and definitions:

Gengtek recommended communication rates are: (higher baud rates are fine but 9600 is by far the most common and is sufficient for the volume of data being transmitted)

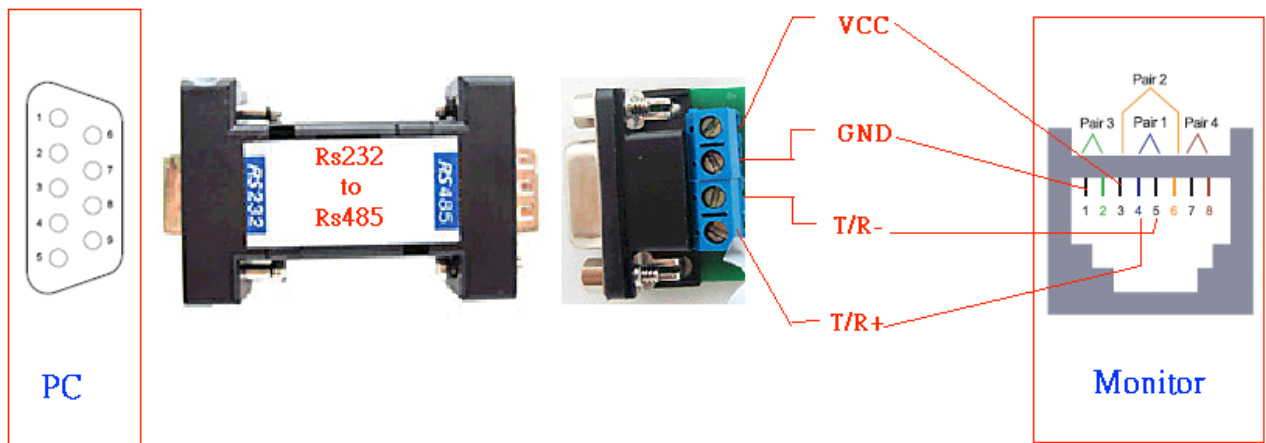

Baud Rates	9600
Data Bits	8
Stop Bits	1
Parity	No

4.3 Data structure

Note • All numbers shown in the protocol description are in hexadecimal unless indicated otherwise. Percentages are shown in decimal.

General Command Form

- STX. The first character is the standard Start of Text (STX) character 0x02.
- Address. The second character is the device address. If a device does not support addressing, these should be 00 and 00 to act as the global address.
- Type. The third character is the command type. There are four types of commands:
 - o Command 00
 - o Ack 01
 - o Nak 02 (option)
 - o Notification 03 (option)
- Property ID. The four and fifth characters are the property identifier. By using one byte we have 256
- Data Length. The sixth character is the number of characters in the parameter data section.
- Data. Following the sixth character is the parameter data section that is as many characters long as the sixth character indicates. If the sixth character is 00 (as with the Reset command for example) then there are no characters in the parameter section. This parameter section contains the value for the property.
- ETX. The last character is the standard End of Text (ETX) character 03.

Sample:

STX	Address	Type	Property ID		Length	Data	ETX
02	00	00	00	01	01	01	03

In this example (Power On to everything), the Address character 00, which is the global address for all devices connected to the serial port. The Type character is 00 to indicate the transmission is a command. The Property ID characters indicate a property identifier of 1, which in this protocol is the value for power. The Length character is a 1, which indicates that there is one character of data associated with this command. The Data has a value of 1, which is the value for ON. The ETX is command End code.

4.4 Command code

4.4.1 User command

In the following samples, the global device address of 00 is used.

The numbers in brackets are the hexadecimal value that Gengtek has associated with the property or the property value.

Note that these values are used in the command string.

For the properties that support ranges such as brightness and volume, examples are provided for low, and high. Any intervening values can be deduced from these.

This section only covers the commands sent from the computer to the device. For responses from the device, see sections 4.2 – ACKs/Notifications and 4.3 – NAKs.

Command		1	3	4	5	6	7	8	9	
Power	OFF	02	00	00	00	01	01	00	03	
	ON							01		
Input Source	VGA	02	00	00	00	02	01	01	03	
	DVI							02		
	AUX							03		
Brightness	0%	02	00	00	00	03	01	00	03	
	100%							64		
Contrast	0%	02	00	00	00	04	01	00	03	
	100%							64		
Colck	0%	02	00	00	00	05	01	00	03	
	100%							64		
Phase	0%	02	00	00	00	06	01	00	03	
	100%							64		
Sharpness	0	02	00	00	00	07	01	00	03	
	5							04		
Horizontal Position	0%	02	00	00	00	08	01	00	03	
	100%							64		
Vertical Position	0%	02	00	00	00	09	01	00	03	
	100%							64		
OSD H Position	0%	02	00	00	00	0A	01	00	03	
	100%							64		
OSD V Position	0%	02	00	00	00	0B	01	00	03	
	100%							64		
OSD Time	4	02	00	00	00	0C	01	00	03	
	30							1E		
Color Red	0%	02	00	00	00	0D	01	00	03	
	100%							64		
Color Green	0%	02	00	00	00	0E	01	00	03	
	100%							64		
Color Blue	0%	02	00	00	00	0F	01	00	03	
	100%							64		

Color Temperature		02	00	00	00	10	01	00	03	
								04		
Language		02	00	00	00	11	01	00	03	
								06		
Auto Color		02	00	00	00	20	00		03	
Auto Processing		02	00	00	00	21	00		03	
Auto Ambient Light	OFF	02	00	00	00	22	01	00	03	
	ON							01		
Auto Notification	OFF	02	00	00	00	23	01	00	03	
	ON							01		
Serial Exclusive	OFF	02	00	00	00	30	01	00	03	
	ON							01		
On Screen Menu	OFF	02	00	00	00	31	01	00	03	
	ON							01		
Screen Wall		02	00	00	00	32	02	0000	03	
								FFFF		
Monitor ID		02	00	00	00	FF	01	00	03	
								FF		
Ping		02	01	00	00	50	00		03	Note *
Query		02	01	00	00	51	02	0000	03	Note *
								FFFF		
Reset		02	00	00	FF	00	00		03	
Factory Mode		02	00	00	FF	01	00		03	
Engineer Mode		02	00	00	00	0C	01	00	03	
								FF		

Note * the system doesn't allow to "Ping/ Query/ Bulk Query" more then one device at one time.

4.4.2 ACKs/ Notifications

The device should return an acknowledgement for “Ping and Query” command

The structure of an ACK is just like a command. The only thing that changes is the Type character which is **01** (Column 3) for an ACK. The ACK includes the address of the device, the property ID, data length, and property value the same as the command.

A sample is provided of the ACK string from a successful Power command:

the command Query Power form monitor ID 01(02 01 00 00 51 02 00 01 03)

02 01 01 00 51 03 00 01 01 03.

Above in blue is ACK for Power status.



205 Westwood Ave, Long Branch, NJ 07740
Phone: 866-94 BOARDS (26273) / (732)-222-1511
Fax: (732)-222-7088 | E-mail: sales@touchboards.com