

MOBI WMK Assembly Guide

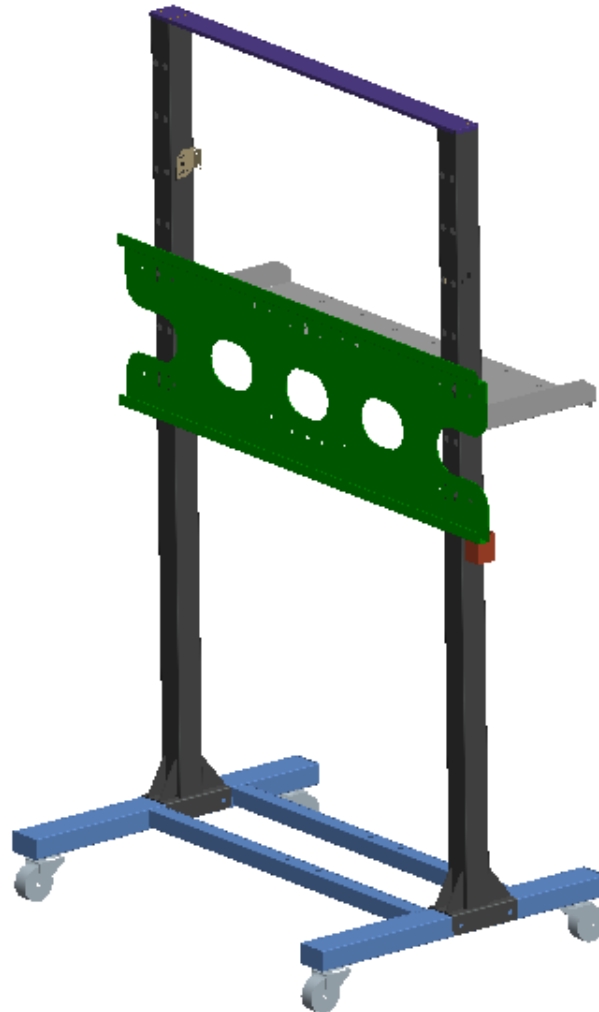

REV.A1

MOBI WMK-F4 Assembly Guide

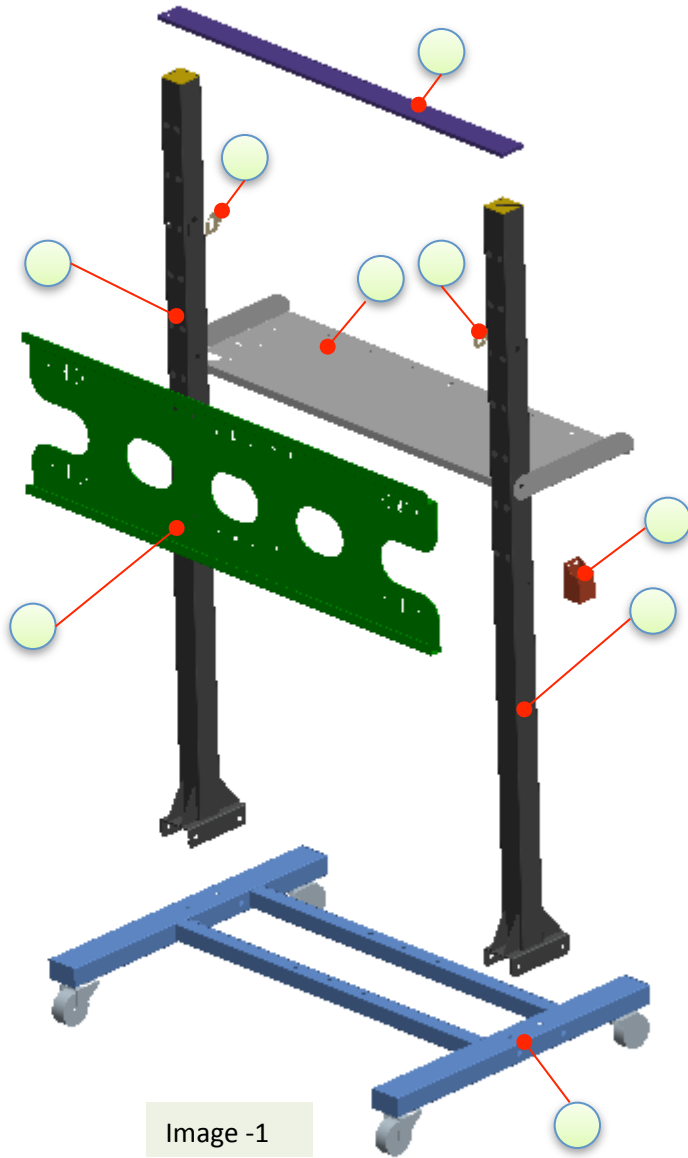









Image -1

WMK-F4 BOM list			
Item	Part Name	Qty	Remark
1	Base	1	Image -1
2	Base support	2	Image -1
3	Stand support bracket	1	Image -1
4	Wall mount	1	Image -1
5	Pen holder	1	Image -1
6	Left Lock Plate	1	Image -1
7	Right Lock Plate	1	Image -1
8	PC table	1	Image -1
9	Screw M4*8mm, P Head, Black	2	
10	Screw M8*15mm, B Head, Black	12	
11	Washer M8, Black	12	
12	Washer ID=7mm OD=19mm H=1mm	4	
13	Screw M10*25mm, Six - angled screw, Black	4	
14	Screw M3*6mm Flat Head, Black	3	
15	Screw M6*12, hexagonal screw	2	
16	Lobe knobs screw M6*16L	2	

MOBI WMK-F4 Assembly Guide

Step 1.

Lock the brakes of the castors before doing any assembly for safety purposes.

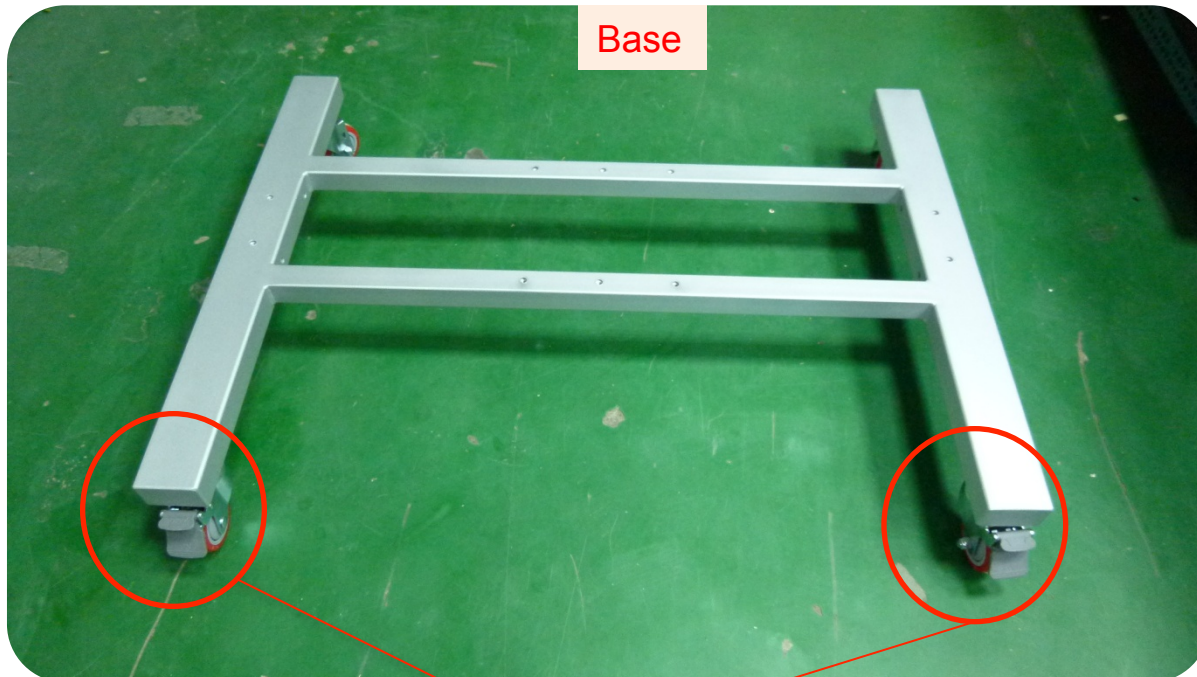

Lock

MOBI WMK-F4 Assembly Guide

Step 2.

Attach the base supports to the base with 12 screws (M8*15mm, B Head) + washer (M8).

Screw M8*15mm B Head_Black +M8 Washer, Black

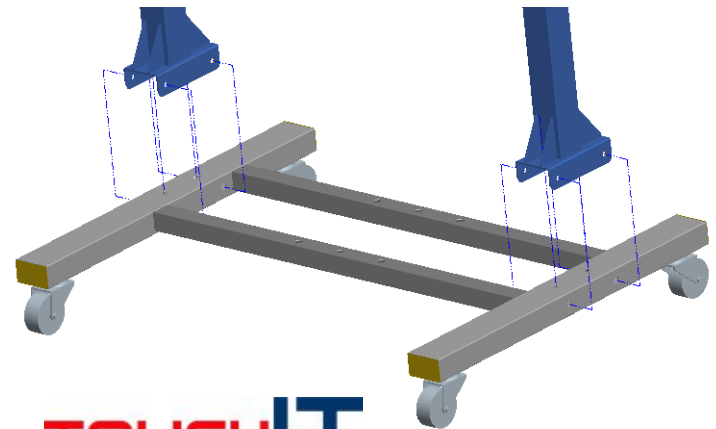
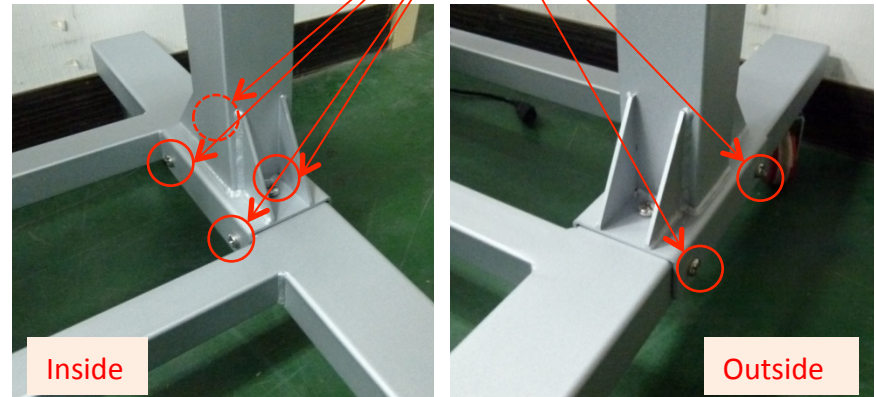
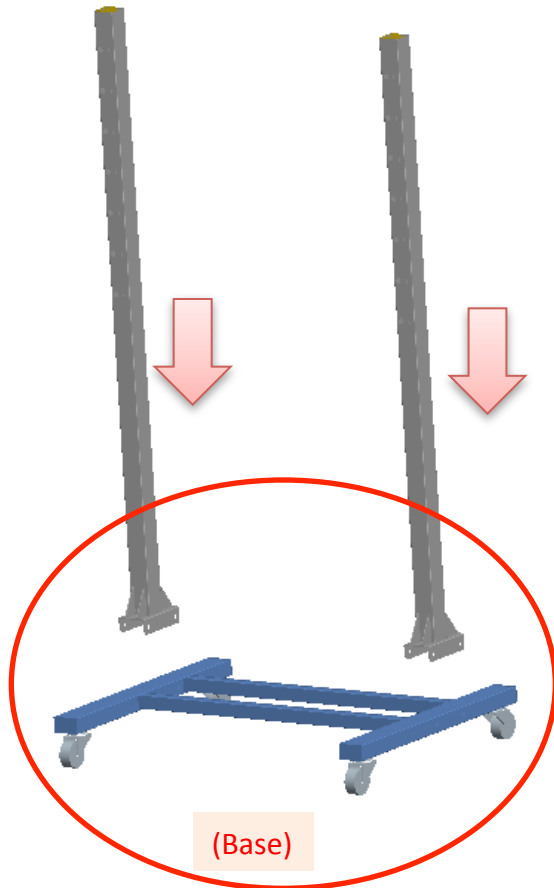

MOBI WMK-F4 Assembly Guide

Step 3.

Place the base support bracket on top of the base supports and fix in place with 2 screws (M4*6mm, P Head, Black).

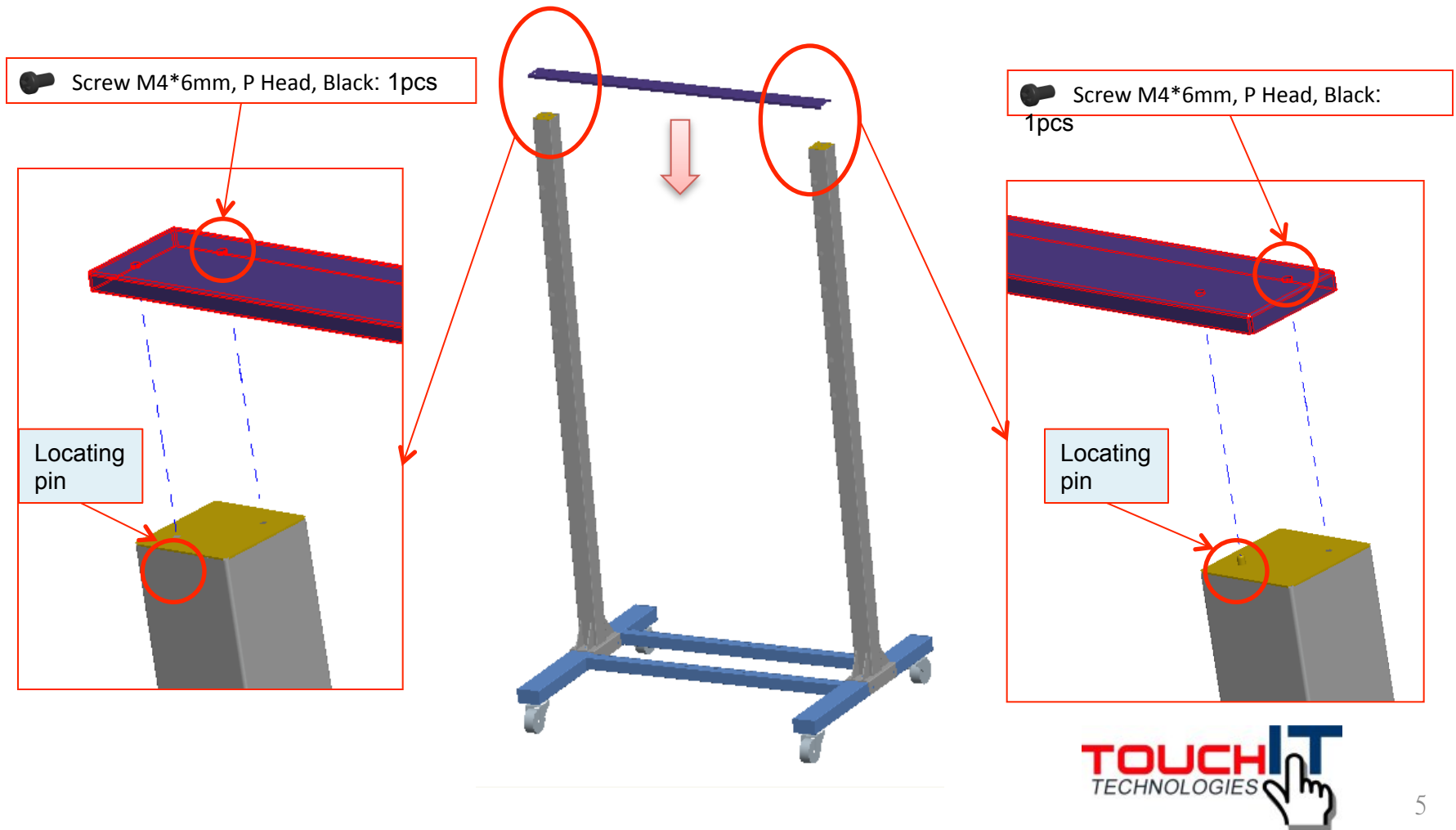

MOBI WMK-F4 Assembly Guide

Step 4.

Attach the wall mount to the base supports then fix it in place with six-angled screw (M10*25mm, Black) + washer (ID=7mm,OD=19mm,H=1mm).

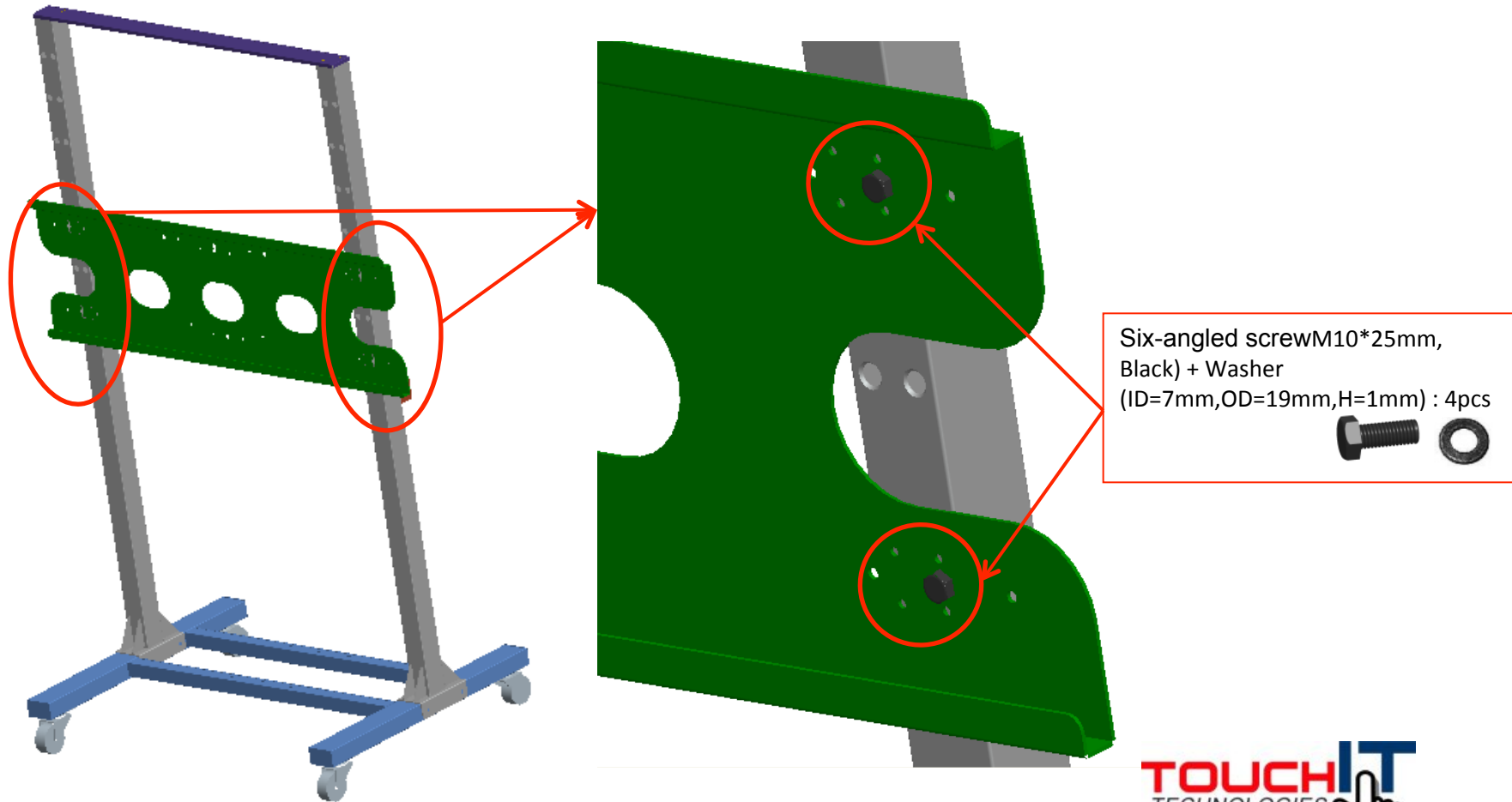

MOBI WMK-F4 Assembly Guide

Step 5.

1. Attach the PC table to the base supports, then fix it in place with n2 Lobe screw nobs M6*16L*2pcs. (Image 2, 2-1)
2. Place Left & Right Lock Plate on base supports, then fix it with 2 screws M6*12, hexagonal screw. (Image 3, 3-1)

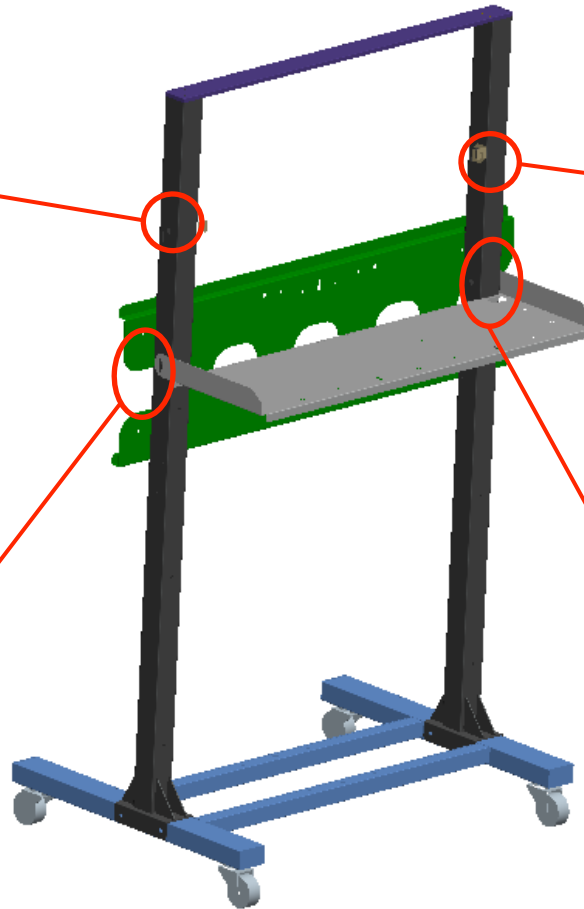
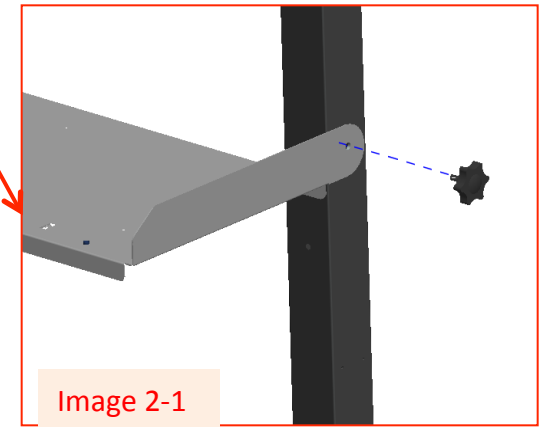
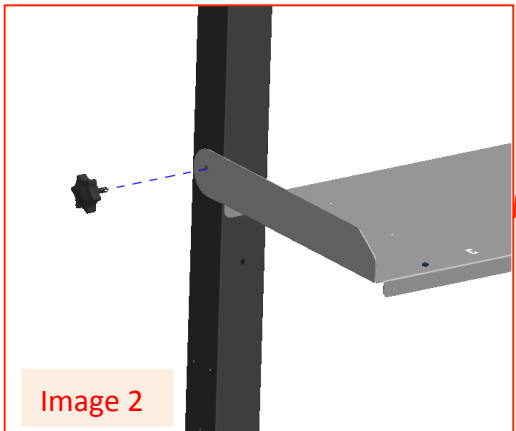
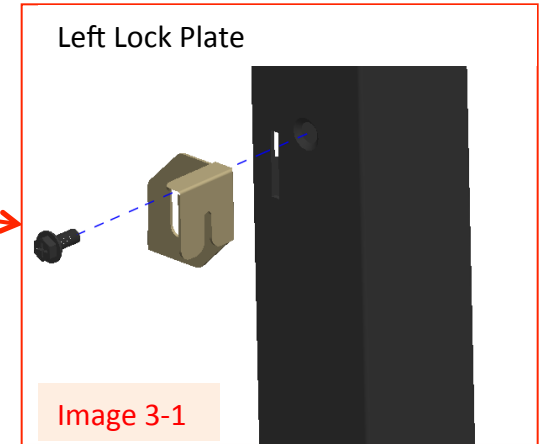
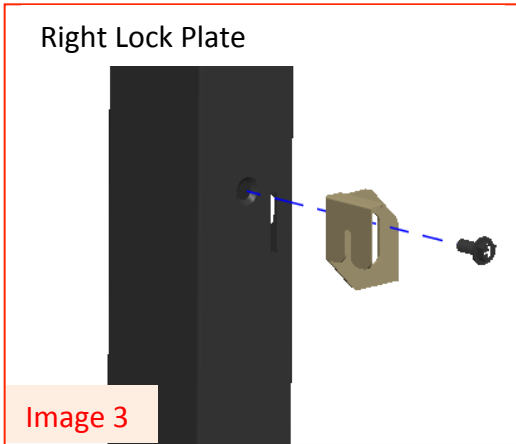

MOBI WMK-F4 Assembly Guide

Step 6.

Both sides of the upright supports support have screw holes for pen holder which can be fixed to either side by the user. Use 3 screws (M3*6mm, Flat Head, Black). (Image 4.)

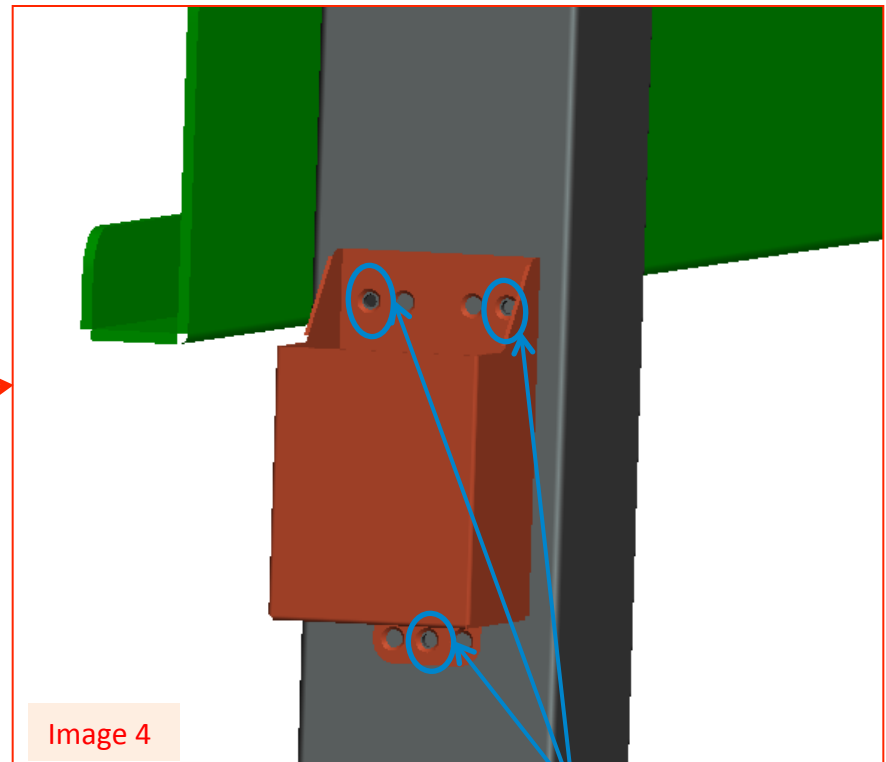
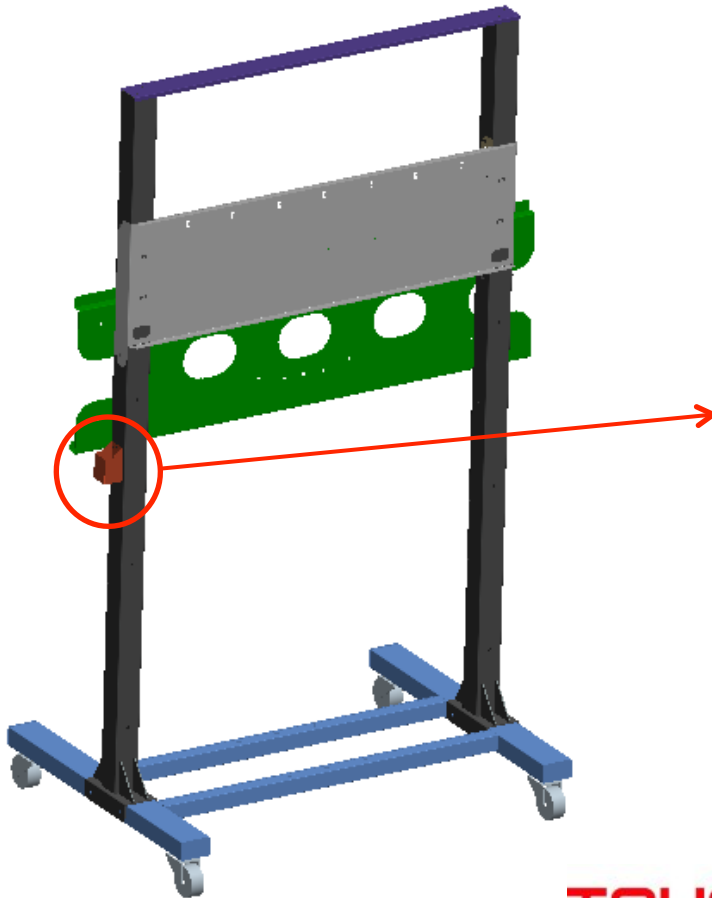

Image 4

Screw (M3*6mm, Flat Head, Black): 3pcs 

MOBI WMK-F4 Assembly Guide

Step 7. PC table

Pull up the left and right lock plate. Flip up the PC tray and fix with the locking plate (Image 5,5-1,5-2), (Image 6).

