

User Manual



MG530

Insulation Tester and Digital Multimeter



Content	Page
1. Precautions and Safety Measures.....	4
1-1. International Safety Symbols.....	4
1-2. Safety Information.....	4
1-3. Input Protection Limits.....	5
1-4. Per IEC1010 Overvoltage Installation Category.....	6
1-5. Electromagnetic Environment.....	6
2. General Description.....	7
3. Description.....	8
3-1. Meter Description.....	8
3-2. Description of the Display.....	9
3-3. Button Function.....	10
4. Operating Instructions.....	11
4-1. DC/AC+DC Voltage Measurement.....	11
4-2. AC Voltage Measurement.....	12
4-3. Low Z AC/DC Voltage Measurement.....	13
4-4. Resistance Measurement and Continuity Test.....	14
4-5. AC Current (with Current Transducer) Measurement.....	15
4-6. Insulation Resistance Measurement.....	16
5. Maintenance.....	17
5-1. The Internal Battery.....	17
5-2. Replacement of Internal Fuses.....	18
5-3. Cleaning the Instrument.....	18
5-4. End of Life.....	18
6. Specifications.....	19
6-1. Technical Specifications.....	19
6-2. General Specifications.....	22
7. Accessories Provided.....	22

1. Precautions and Safety Measures

- The instrument has been designed in compliance with directive IEC/EN61010-1 relevant to electronic measuring instruments.
- For your safety and in order to prevent damaging the instrument, please carefully follow the procedures described in this manual and read all notes preceded by symbol with the utmost attention.

1-1. International Safety Symbols

 **WARNING:** observe the instructions given in this manual; improper use could damage the instrument or its components.

 Double-insulated meter

 AC voltage or current

 DC voltage or current

 Connection to earth

 DO not test Voltage more than 550V

1-2. Safety Information

This meter has been designed for safe use, but must be operated with caution, the rules listed below must be carefully followed for safe operation.

- Do not carry out any measurement in humid environments.
- Do not carry out any measurements in case gas, explosive materials or flammables are present, or in dusty environments.
- Avoid any contact with the circuit being measured if no measurements are being carried out.
- Avoid any contact with exposed metal parts, with unused measuring probes, circuits, etc.
- Do not carry out any measurement in case you find anomalies in the instrument such as deformation, breaks, substance leaks, absence of display on the screen, etc.
- Before each use, verify meter operation by measuring a known voltage.
- Do not use the meter on a circuit with voltages that exceed the category based rating of this meter.
- Do not use the meter during electrical storms or in wet weather.
- Do not use the meter or test leads if they appear to be damaged.
- Use Only with CAT IV rated test leads.
- Ensure meter leads are fully seated, and keep fingers away from the metal probe contacts when making measurements.
- Do not open the meter to replace batteries while the probes are connected.
- Use caution when working with voltages above 25V AC RMS or 60V DC, such voltages pose a shock hazard.
- To avoid false readings that can lead to electrical shock, replace batteries when a low battery indicator appears.

- Do not attempt to measure resistance or continuity on a live circuit.
- Make sure the circuit under test does not include components that can be damaged by 1000VDC; such devices include power factor correction capacitors, low voltage mineral insulated cables, electronic light dimmers, and ballast/starters for fluorescent lamps.
- Do not perform insulation resistance testing or earth-bond resistance testing if voltage is present on parts of an installation or equipment under test, circuits under test (except for voltage measurements) must be de-energized and isolated before connections are made.
- Circuit connections must not be touched during a test, accidental contact with conductors could result in electrical shock.
- After insulation resistance testing, make sure the circuit is fully discharged before removing test leads, LCD should read close to zero volts.
- Always adhere to local and national safety codes.
- Use personal protective equipment to prevent shock and arc blast injury where hazardous live conductors are exposed.
- Never apply voltage or current to the meter that exceeds the specified maximum.
- Use extreme CAUTION when working with high voltages.
- Do not measure voltage if the voltage on the "COM" input jack exceeds 1000V above earth ground.
- Never connect the meter leads across a voltage source while the function switch is in the current, resistance or diode mode, doing so can damage the meter.
- Always discharge filter capacitors in power supplies and disconnect the power when making resistance or diode tests.
- Always turn off the power and disconnect the test leads before opening the covers to replace the fuse or batteries.
- Never operate the meter unless the back cover and the battery and fuse covers are in place and fastened securely.
- If the equipment is used in a manner not specified by the manufacturer, the protection provided by the equipment may be impaired.

1-3. Input Protection Limits

Function	Maximum Input
V DC or V AC	1000VDC/AC rms
Electrical Resistance and Continuity	500mA 1000V fast acting fuse
3000A AC	1000V DC/AC rms
Insulation Resistance Measurement	550V DC/AC rms
AC+DC Measurement	1000VDC/AC rms
Surge Protection: 8kV peak per IEC 61010	

1-4. Per IEC1010 Overvoltage Installation Category

- **Overvoltage Category I:** Equipment of Overvoltage Category I is equipment for connection to circuits in which measures are taken to limit the transient overvoltages to an appropriate low level.

Note: Examples include protected electronic circuits.

- **Overvoltage Category II:** Equipment of Overvoltage Category II is energy-consuming equipment to be supplied from the fixed installation.

Note: Examples include household, office, and laboratory appliances.

- **Overvoltage Category III:** Equipment of Overvoltage Category III is equipment in fixed installations.

Note: Examples include switches in the fixed installation and some equipment for industrial use with permanent connection to the fixed installation.

- **Overvoltage Category IV:** Equipment of Overvoltage Category IV is for use at the origin of the installation.

Note: Examples include electricity meters and primary over-current protection equipment.

1-5. Electromagnetic Environment

IEC EN 61326-1, this equipment meets requirements for use in basic and controlled electromagnetic environments like residential properties, business premises, and light-industrial locations

2. General Description

- The instrument carries out the following measurements:
 - DC voltage
 - AC, AC+DC TRMS Voltage
 - LPF, Low Pass Filter
 - Low Z AC/DC Voltage
 - 30A, 300A, 3000A AC TRMS Current with Current Transducer
 - Resistance and Continuity Test
 - Frequency
 - Insulation Tester
- Each of these functions can be selected by means of the appropriate switch.
- The instrument is also equipped with function keys, analogue bargraph and LCD display.
- The instrument is also equipped with an Auto Power OFF function which automatically switches off the instrument after a certain (programmable) idling time.

3.Description

3-1.Meter Description

- 1-LCD Display
- 2-RANGE Button
- 3-ZERO Button
- 4-Backlight Button
- 5-MAX/MIN Button
- 6-MODE Button
- 7-TEST Button
- 8-HOLD Button
- 9-LOCK Button
- 10-Rotary Selector Switch
- 11-Lanyard Hole
- 12-Test Lead Holders
- 13-Battery Cover
- 14-Tilt Stand
- 15-Input Terminal $\Omega / \text{Hz} / \text{V}$ +
- 16-Input Terminal COM
- 17-Input Terminal Test Lead
- 18-Input Terminal $\Omega / \text{Hz} / \text{V}$ -/INSULATION-
- 19-Input Terminal V/Hz/3000A/INSULATION+

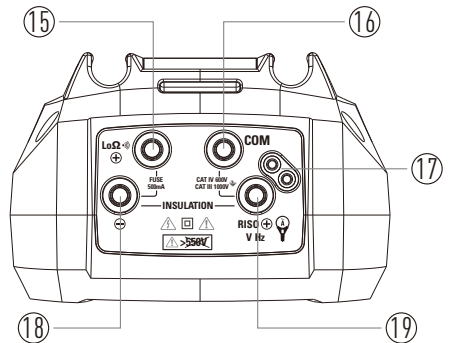
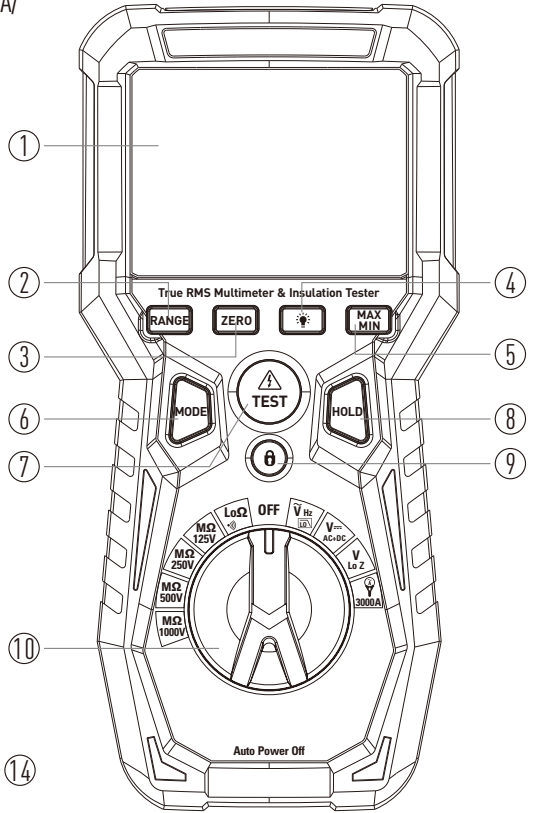
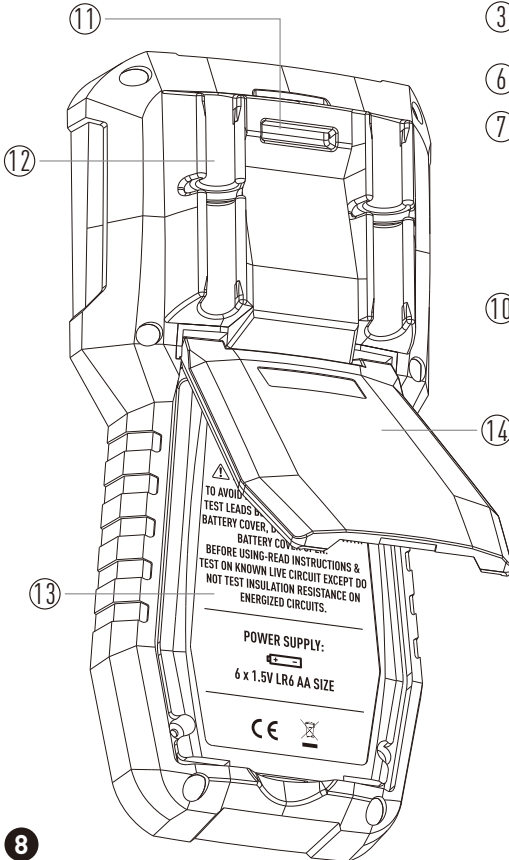

3-2. Description of the Display

- 1-Minimum Value
- 2-Zero Adjustment
- 3-Low Pass Filter
- 4-Data Hold
- 5-Auto Range
- 6-Maximum Value
- 7-Bar Graph
- 8-Main Display
- 9-Alternating Current
- 10-Direct Current
- 11-Minus Sign
- 12-Greater Than
- 13-Auto Power Off
- 14-Low Battery
- 15-Test Voltage
- 16-Test Lock
- 17-Current Transducer
- 18-Low Impedance Test Mode
- 19-Low Input Impedance
- 20-Sub Display
- 21-Frequency
- 22-Units of Measure List
- 23-Audible Continuity

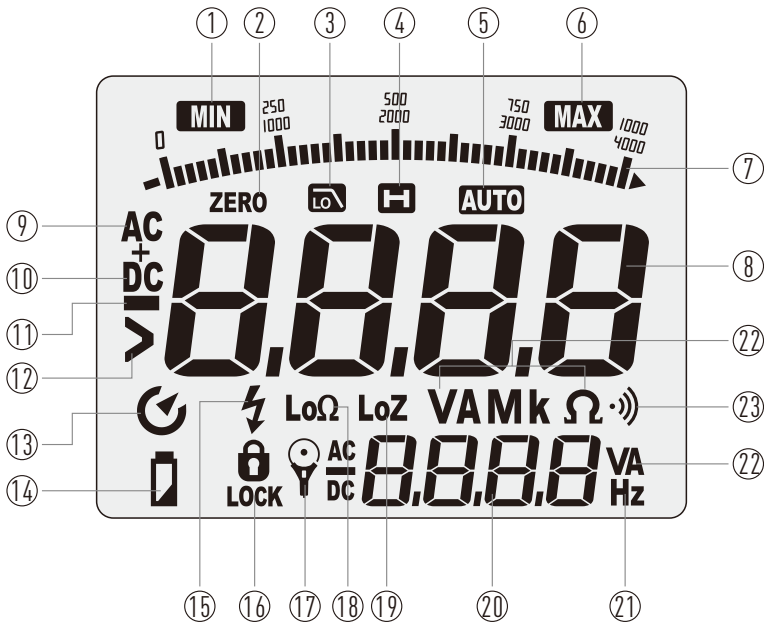

3-3.Button Function

3-3-1.RANGE Button

- Press the **RANGE** Button to activate the manual mode and to disable the Autorange function.
- The message “**Manual**” appears on the upper left part of the display instead of “**AUTO**”.
- In Manual mode, press the **RANGE** Button to change measuring range: The relevant decimal point will change its position, the **RANGE** Button is not active in positions $Lo\Omega$, $Lo\Omega$, $INSULATION$, $Lo Z$ Voltage.
- In Autorange mode, the instrument selects the most appropriate ratio for carrying out measurement.
- If a reading is higher than the maximum measurable value, the indication “**O.L**” appears on the display.
- Press and hold the **RANGE** Button for more than 1 second to exit the manual mode and restore the Autorange mode.
- Press the **RANGE** Button to select “30A, 300A, 3000A”.

3-3-2.Backlight Button

- Press and hold the **Backlight** Button for more than one second to turn the backlight on or off.
- The backlight will automatically turns off after approximately 3 minutes.

3-3-3.MAX/MIN Button

- When the **MAX/MIN** Button is pressed, the meter keeps track of the minimum and maximum value of the measurement for VAC, VDC, Continuity and Ohms.
- The first press of the **MAX/MIN** Button displays the MAX value, the second press displays the MIN value.
- To return to normal measuring mode, press and hold the **MAX/MIN** Button for more than one second.

3-3-4.MODE Button

- Momentarily press the **MODE** Button to select AC Voltage, LPF or Frequency , DC Voltage or AC+DC Voltage.
- The meter will automatically power OFF after 15 minutes of inactivity, to disable auto-power off, press and hold the **MODE** Button while powering on.
- Press and hold the **MODE** Button to select the low-pass filter mode.

3-3-5.HOLD Button

- Press the **HOLD** Button to hold the measurement on the display.
- Press again to release the display to return to live measuring (not for insulation resistance testing).

3-3-6.TEST Button

- With the test leads connected to the equipment under test, press and hold the **TEST** Button to begin an insulation resistance test.
- The lower-right display will show test voltage, and the main display will show the resistance.

3-3-7.LOCK Button

- For hands-free insulation resistance testing, use the **LOCK** Button feature.
- With the test leads connected to the equipment under test, press the **LOCK** Button for two seconds, and then press the **TEST** Button to begin the test.
- The lock icon will appear on the display and the meter will beep to indicate it is in lock mode.
- Press the **TEST** Button to end the test.

4. Operating Instructions

4-1. DC/AC+DC Voltage Measurement

⚠ CAUTION: The maximum input DC voltage is 1000V. Do not measure voltages exceeding the limits given in this manual. Exceeding voltage limits could result in electrical shocks to the user and damage to the instrument.

1. Set the function switch to the **V_{DC}/AC+DC** Position.
2. Insert the black test lead into the Input Terminal **COM** and the red test lead into the Input Terminal **V/HZ/3000A/INSULATION+**.
3. Position the red lead and the black lead respectively in the spots with positive and negative potential of the circuit to be measured.
4. The display shows the value of voltage.
5. If the display shows the message "O.L", select a higher range.
6. For AC+DC measurement, press the **MODE** Button to indicate "AC+DC" on the display.

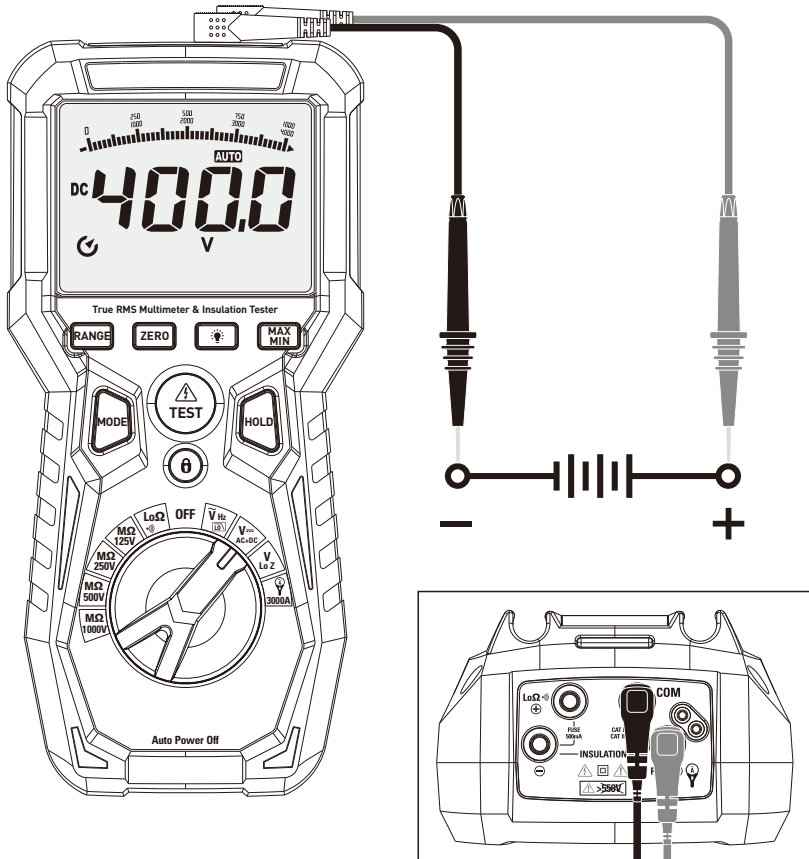

4-2.AC Voltage Measurement

⚠ CAUTION: The maximum input AC voltage is 1000V. Do not measure voltages exceeding the limits given in this manual. Exceeding voltage limits could result in electrical shocks to the user and damage to the instrument.

- 1.Set the function switch to the **V~/Hz/LPF** Position.
- 2.Insert the black test lead into the Input Terminal **COM** and the red test lead into the Input Terminal **V/HZ/3000A /INSULATION+**.
- 3.Position the black test probe tip and red test probe tip respectively in the spots of the circuit to be measured.
- 4.Read the AC voltage in the display.
- 5.If the display shows the message “**0.L**”, select a higher range.
- 6.Press the **MODE** Button to select measurements “**Hz**” in order to display the values of frequency input voltage.
- 7.Press the **MODE** Button to select low pass filter test.
- 8.Press and hold the **MODE** Button to indicate “**Lo**” on the display.

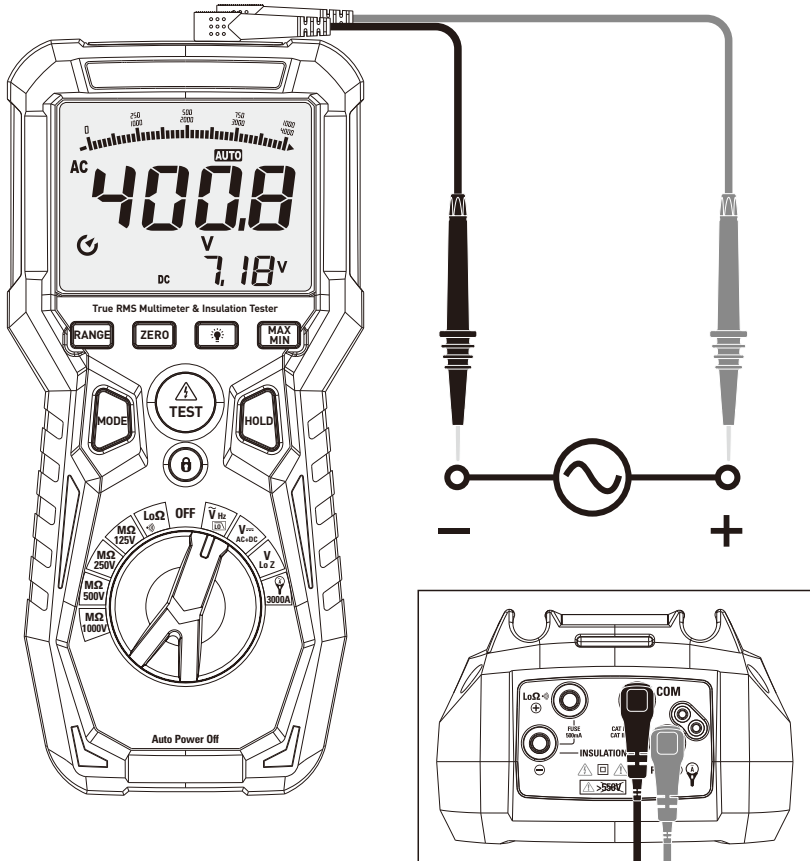

4-3. Low Z AC/DC Voltage Measurement

⚠ CAUTION: Observe all safety precautions when working on live voltage. Do not connect to circuits that exceed 1000V when the meter is set to Low z. Do not use Low Z when testing circuits that could be harmed by this function's low input impedance. Let the meter stabilize 15 minutes after using Lo Z.

- Low Z is used to check for "ghost" voltage.
- Ghost voltages are present when non-powered wires are in close proximity to wires powered wires.
- Capacitive coupling between wires make it appear that non-powered wires are connected to a real source of voltage.
- The Low Z setting places a load on the circuit, which greatly reduces the voltage reading when connected to ghost voltage.

1. Set the function switch to the **Low Z** Position.

2. Insert the black test lead into the Input Terminal **COM** and the red test lead into the Input Terminal **V/Hz/3000A /INSULATION+**.

3. Touch the test leads to the circuit under test.

4. If the display shows the message "**0.L**", select a higher range.

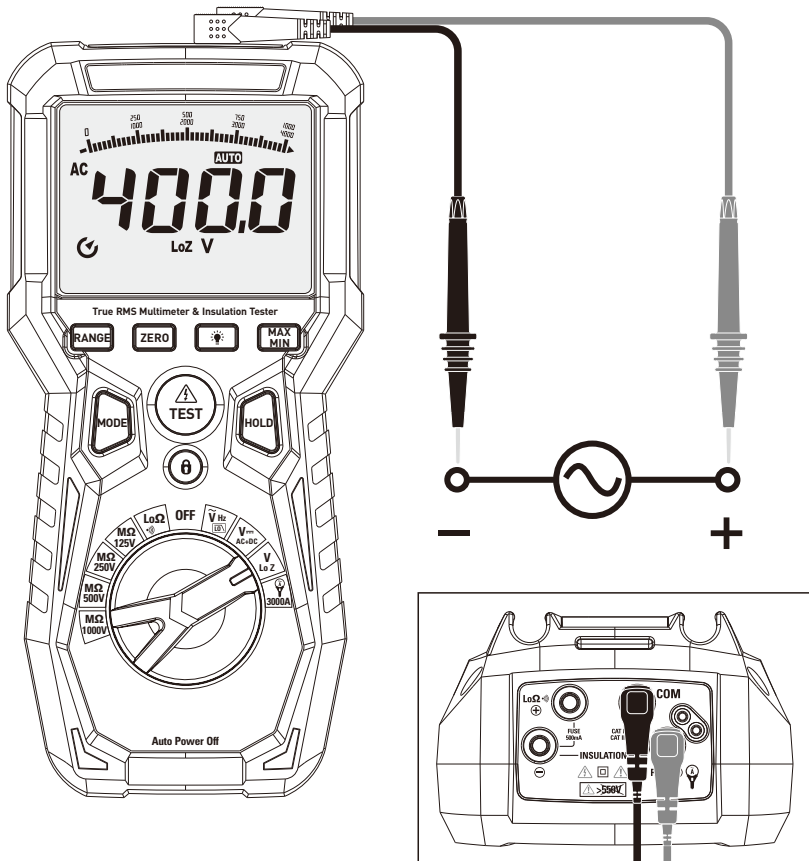

4-4. Resistance Measurement and Continuity Test

⚠ CAUTION: Before attempting any resistance measurement, cut off power supply from the circuit to be measured and make sure that all capacitors are discharged, if present.

1. Set the function switch to the **Lo Ω** Position.
2. Insert the black test lead into the Input Terminal **Ω** -/INSULATION- and the red test lead into the Input Terminal **Ω** +.
3. Position the test leads in the desired spots of the circuit to be measured.
4. The display shows the value of resistance.
5. If the display shows the message “**O.L**”, select a higher range.
6. The value of resistance (which is only indicative) is displayed in Ω and the instrument sounds if the value of resistance is $<30 \Omega$.

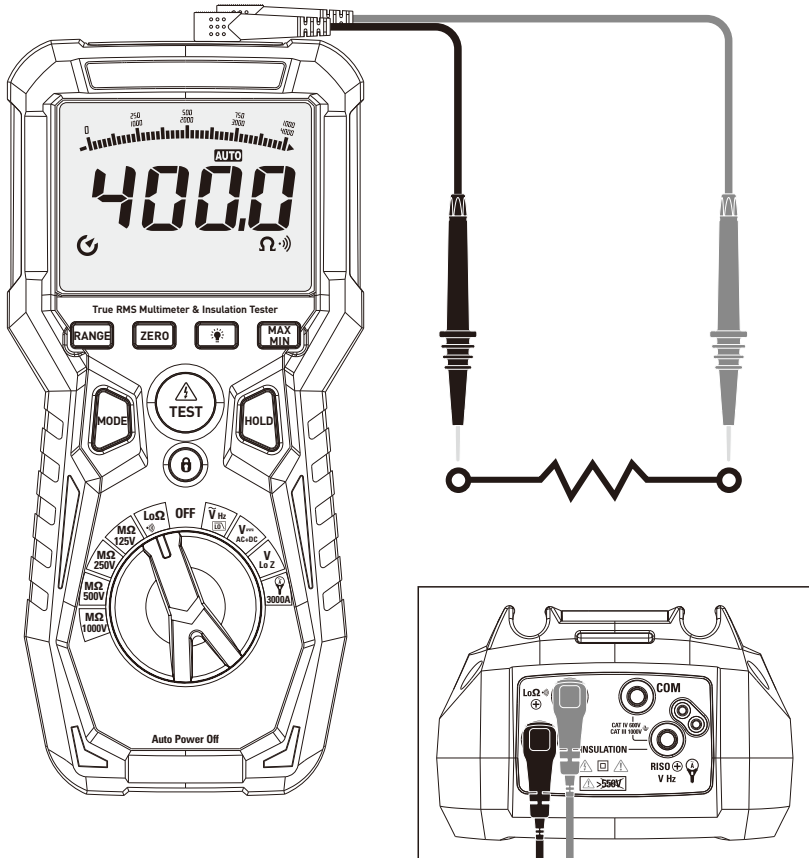

4-5.AC Current (with Current Transducer) Measurement

⚠ CAUTION: Maximum input AC current is 3000A (input VHz). Do not measure currents exceeding the limits given in this manual.

- 1.Set the function switch to the **3000A** Position.
- 2.Insert the black test lead into the Input Terminal **COM** and the red test lead into the Input Terminal **V/Hz/3000A /INSULATION+**.
- 3.Press the **RANGE** Button to select “30A, 300A, 3000A” AC Current measurement.
- 4.Select current Transducer Rang.
- 5.Press the lock catch to open jaw, fully enclose only one conductor, for optimum results, center the conductor in the jaw.
- 6.The meter LCD will display the reading.

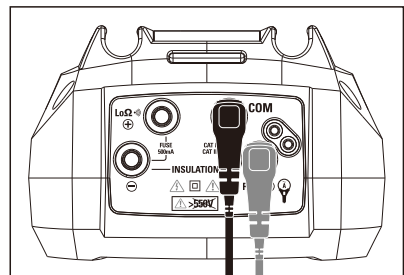
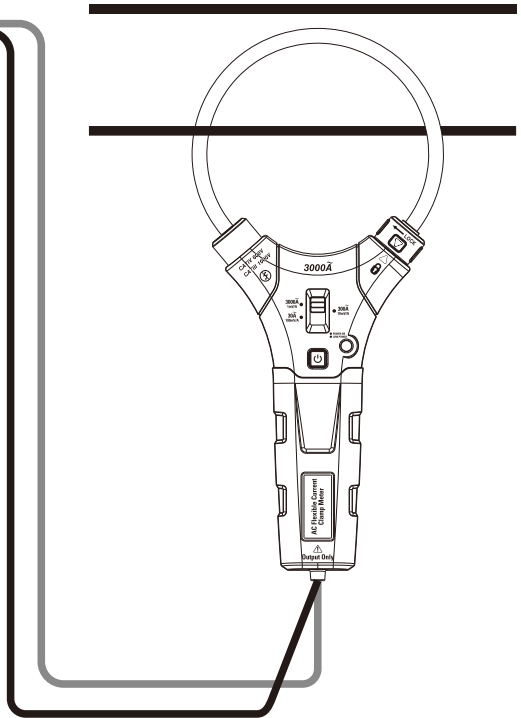
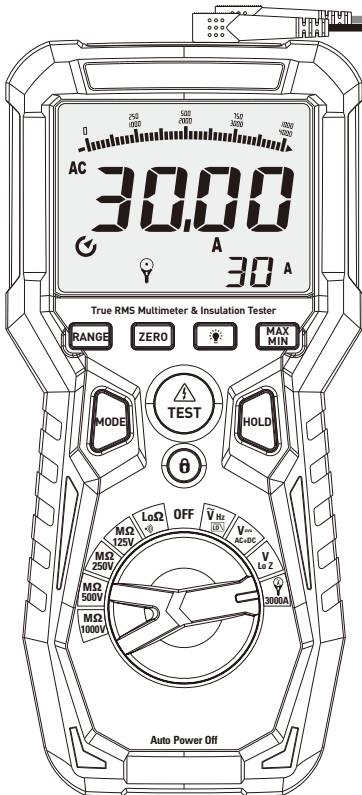

4-6. Insulation Resistance Measurement

⚠ CAUTION: Measurements can be adversely affected by impedances of additional operating circuits connected in parallel or by transient currents.

1. Insert the red cable into Input Terminal **INSULATION+**, and the black cable into Input Terminal **INSULATION-**, and rotate the function selector to the desired test voltage.

2. Choose from 125V, 250V, 500V or 1000V based on the compatibility with the device tested.

Note: Disconnect the circuit under test and isolate it from any stray resistance, Insulation test should only be performed on de-energized circuits.

3. Connect the Red and Black cable to the circuit under test, if there is a voltage in the circuit, a constant beep will sound and the Test Voltage symbol will be displayed, disconnect the circuit to proceed.

4. Press and hold the **TEST** Button to begin test, the lower right display shows test voltage, and the main display shows the resistance.

5. The measured insulation resistance is displayed on the main display in $M\Omega$, allow the reading to stabilize before recording the measurement, turning the function switch, at any time during the insulation test will end the testing process.

6. The circuit will discharge through the meter, keep the test leads connected until the circuit is completely discharged and the lower right display shows near zero volts.

Note: Measurements can be adversely affected by impedances of additional operating circuits connected in parallel or by transient currents.

Note: Overload "----" for insulation resistance measurements.

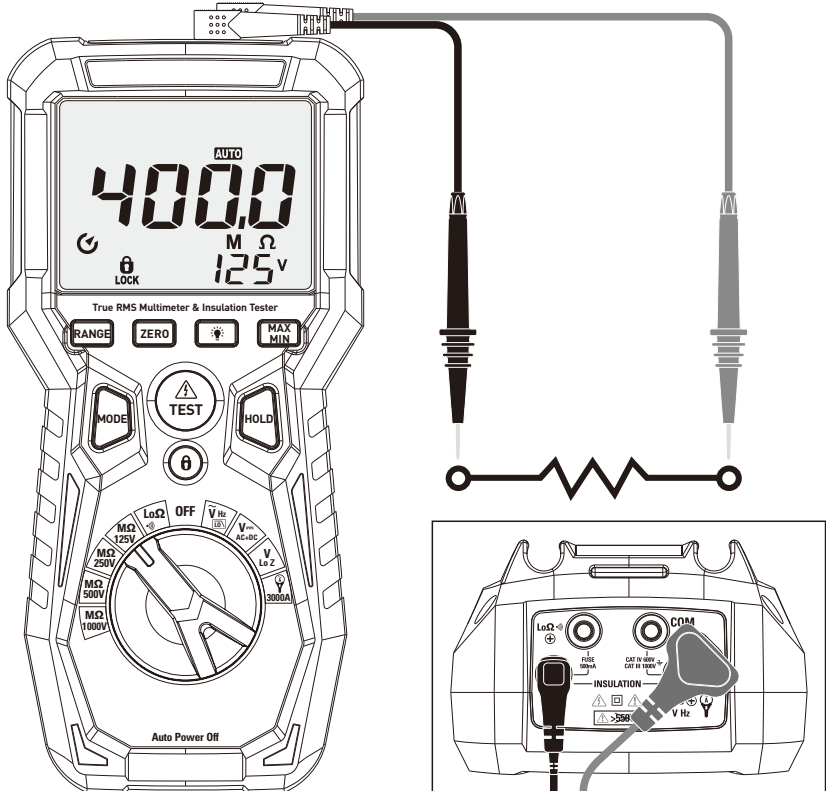

5. Maintenance

⚠ CAUTION:

- Only expert and trained technicians should perform maintenance operations.
- Before carrying out maintenance operations, disconnect all cables from the input terminals.
- Do not use the instrument in environments with high humidity levels or high temperatures, do not expose to direct sunlight.
- Always switch off the instrument after use.
- In case the instrument is not to be used for a long time, remove the battery to avoid liquid leaks that could damage the instrument's internal circuits.

5-1. The Internal Battery

- When the LCD displays symbol "🔋", it is necessary to replace the batteries.
- Refer to Figure and replace the batteries as follows:
 1. Turn the Meter off and remove the test leads from the terminals.
 2. Remove the battery door assembly by using a standard blade screwdriver to turn the battery door screw one-half turn counterclockwise.
 3. Replace the batteries 1.5V AA x 6.
 4. Reinstall the battery door assembly and secure it by turning the screw one-half turn clockwise.

WARNING: To avoid electric shock, disconnect the test leads from any source of voltage before removing the battery cover.

WARNING: To avoid electric shock, do not operate the meter until the battery cover is in place and fastened securely.

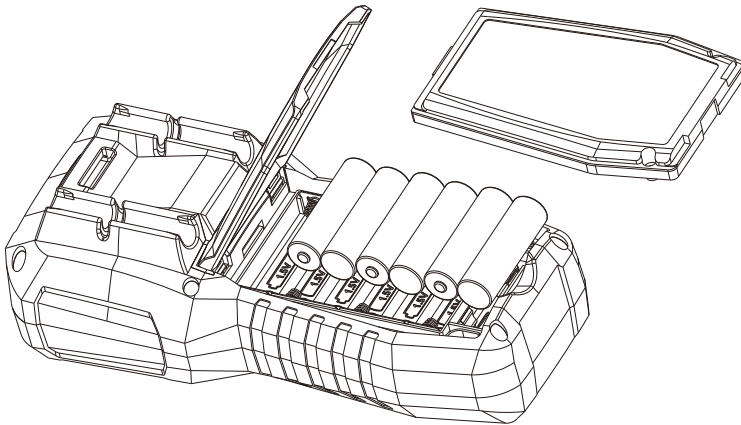

5-2.Replacement of Internal Fuses

Referring to Figure, examine or replace the Meter's fuses as follows:

- 1.Turn the Meter off and remove the test leads from the terminals.
- 2.Remove the battery door assembly by using a standard blade screwdriver to turn the battery door screw one-half turn counterclockwise.
- 3.Remove the fuse by gently prying one end loose, then sliding the fuse out of its bracket.
- 4.Install only specified replacement fuses.
- 5.Reinstall the battery door assembly and secure it by turning the screw one-half turn clockwise.

WARNING: To avoid electric shock, disconnect the test leads from any source of voltage before removing the meter cover.

WARNING: To avoid electric shock, do not operate your meter until the fuse cover is in place and fastened securely.

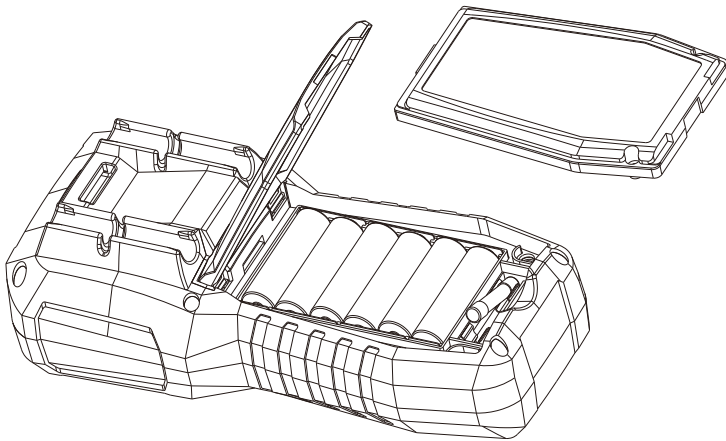

5-3.Cleaning the Instrument

- Use a soft and dry cloth to clean the instrument.
- Never use wet cloths, solvents, water, etc.

5-4.End of Life



WARNING: the symbol on the instrument indicates that the appliance and its accessories must be collected separately and correctly disposed of.

6. Specifications

6-1. Technical Specifications

Accuracy calculated as [%reading + (num. digits*resolution)] at 18 to 28°C; <75%HR.

Function	Range	Resolution	Accuracy	Input Impedance
DC Voltage	4.000V	0.001V	±(0.5% + 5 digits)	>10MΩ
	40.00V	0.01V		
	400.0V	0.1V	±(1.0% + 5 digits)	
	1000V	1V		

Protection against overcharge: 1000VDC/ACrms

Function	Range	Resolution	*Accuracy (50 to 60Hz)	*Accuracy (61 to 1kHz)
AC TRMS Voltage	4.000V	0.001V	±(0.9% + 5 digits)	±(3.0% + 5 digits)
	40.00V	0.01V		
	400.0V	0.1V	±(1.0% + 5 digits)	
	1000V	1V		

Protection against overcharge 1000VDC/ACrms.

(*)Accuracy specified from 10% to 100% of the measuring range, Input impedance: >9MΩ.

Distorted, pulsed, triangle or trapezia waveform Accuracy: (10%rdg + 10dgt).

Function	Range	Resolution	Accuracy (50 to 1kHz)	Input Impedance
AC+DC TRMS Voltage	4.000V	0.001V	±(3.0% + 20 digits)	>10MΩ
	40.00V	0.01V		
	400.0V	0.1V		
	1000V	1V		

Protection against overcharge: 1000VDC/ACrms

Function	Range	Resolution	Accuracy
AC/DC Voltage (Low Z)	4.000V	1mV	±(3.0% + 40 digits)
	40.00V	10mV	
	400.0V	0.1V	
	1000V	1V	

Protection against overcharge: 1000VDC/ACrms

Input Impedance: Approx. ~3kΩ

Function	Range	Transducer Ratio	Resolution	*Accuracy (50 to 1kHz)
AC Current (with Current Transducer)	30A*	100mV/1A	0.01A	±(1.2% + 10 digits)
	300A*	10mV/1A	0.1A	
	3000A*	1mV/1A	10A	

Protection against overcharge: 1000VDC/ACrms

(*) Accuracy specified from 5% to 100% of the measuring range

(*) Do not include the accuracy of current Transducer

* with Current Transducer (30A*/300A*/3000* Rang Corresponding Current Transducer Range)

Distorted, Pulsed, Triangle or Trapezia waveform Accuracy: (10%rdg + 10dgt)

Function	Range	Resolution	Accuracy	Buzzer
Resistance and	40.0Ω	0.1Ω	±(0.5% + 3 digits)	<40Ω
Continuity Test	400.0Ω	0.1Ω	±(2.5% + 8 digits)	

Protection against overcharge: 300VDC/ACrms

Continuity Beeper: Audible signal when resistance <40Ω .

Short circuit >200mA; Open circuit voltage 5.5V DC.

Function	Range	Resolution	Accuracy
Frequency (Electronic)	40.00Hz to 1kHz	0.01Hz to 1Hz	±(0.5%reading)

Protection against overcharge: 1000VDC/ACrms

Sensitivity: 2Vrms

Function	Terminal Voltage	Range	Resolution	Accuracy	Test Current
Insulation Resistances	125V (0%~20%)	0.125 to 4.000M Ω	0.001M Ω	\pm (2.5%+10)	1mA at load 125k Ω
		4.00 to 40.00M Ω	0.01M Ω	\pm (2%+10)	
		40.0 to 400.0M Ω	0.1M Ω	\pm (4%+5)	
		400 to 4000M Ω	1M Ω	\pm (5%+5)	
	250V (0%~20%)	0.250 to 4.000M Ω	0.001M Ω	\pm (2%+15)	1mA at load 250k Ω
		4.000 to 40.00M Ω	0.01M Ω	\pm (2%+10)	
		40.00 to 400.0M Ω	0.1M Ω	\pm (3%+5)	
		400.0 to 4000M Ω	1M Ω	\pm (4%+5)	
	500V (0%~20%)	0.500 to 4.000M Ω	0.001M Ω	\pm (2%+10)	1mA at load 500k Ω
		4.000 to 40.00M Ω	0.01M Ω	\pm (2%+10)	
		40.00 to 400.0M Ω	0.1M Ω	\pm (2%+5)	
		400.0 to 4000M Ω	1M Ω	\pm (4%+5)	
	1000V (0%~20%)	1.000 to 4.000M Ω	0.001M Ω	\pm (3%+10)	1mA at load 1M Ω
		4.000 to 40.00M Ω	0.01M Ω	\pm (2%+10)	
		40.00 to 400.0M Ω	0.1M Ω	\pm (2%+5)	
		400.0 to 4000M Ω	1M Ω	\pm (4%+5)	

Short Circuit <5mA.

Due to the alkaline battery charge, multiple tests so that the 1000 volt voltage through the 1M Ω resistor, generally maintain the test time of about 5 seconds.

Intrinsic Uncertainty (EN61557)

Code	Measurement Intrinsic	Operating Uncertainty	Maximum Uncertainty*
A	Insulation Resistance	See Electrical Specifications	<30%
A	Earth-Bond Resistance	See Electrical Specifications	<30%

Influence Variables and Uncertainties (EN61557)

Code	Variable	Range	% Within Range
E1	Position	\pm 90°	<5%
E2	Supply Voltage	7.21 to 9.13V	<5%
E3	Temperature	0 to 35°C	<5%

6-2. General Specifications

Safety

Safety	IEC EN 61010-1, 61010-2-030, 61010-2-033, 61326-1, 61557-1-2-4.
Insulation	Double Insulation
Pollution Level	2
Overvoltage Category	CAT IV 600V, CAT III 1000V
Max Operating Altitude	2000m (6562ft)

Mechanical Characteristics

Size (L x W x H)	175 x 85 x 55mm (7 x 3 x 2in)
Weight (Batteries included)	800g

Power Supply

Battery Type	6x1.5V AA batteries, 1200mAh
Low Battery Indication	symbol "⏻" on the display
Auto Power Off	after 15 minutes' idling (can be disabled)
Fuses	F500mA/1000V, 6 x 32mm

Display

Conversion	TRMS
Characteristics	LCD, 4000 dots, decimal sign, point backlight and bargraph
Sampling Frequency	3 times/s

Environmental Conditions for Use

Reference Temperature	18 to 28°C (64 to 82°F)
Operating Temperature	5 to 40°C (41 to 104°F)
Allowable Relative Humidity	<80 %RH
Storage Temperature	-20 to 60°C (-4 to 140°F)
Storage Humidity	<80 %RH

7. Accessories Provided

- Pair of Test Leads
- 6x1.5V AA Alkaline Batteries
- Carrying Bag
- User Manual

Warranty

Triplett / Jewell Instruments extends the following warranty to the original purchaser of these goods for use. Triplett warrants to the original purchaser for use that the products sold by it will be free from defects in workmanship and material for a period of (2) two years from the date of purchase. This warranty does not apply to any of our products which have been repaired or altered by unauthorized persons in any way or purchased from unauthorized distributors so as, in our sole judgment, to injure their stability or reliability, or which have been subject to misuse, abuse, misapplication, negligence, accident or which have had the serial numbers altered, defaced, or removed. Accessories, including batteries are not covered by this warranty.

Copyright © 2023 Triplett
www.triplett.com