

## INSTALLATION INSTRUCTIONS

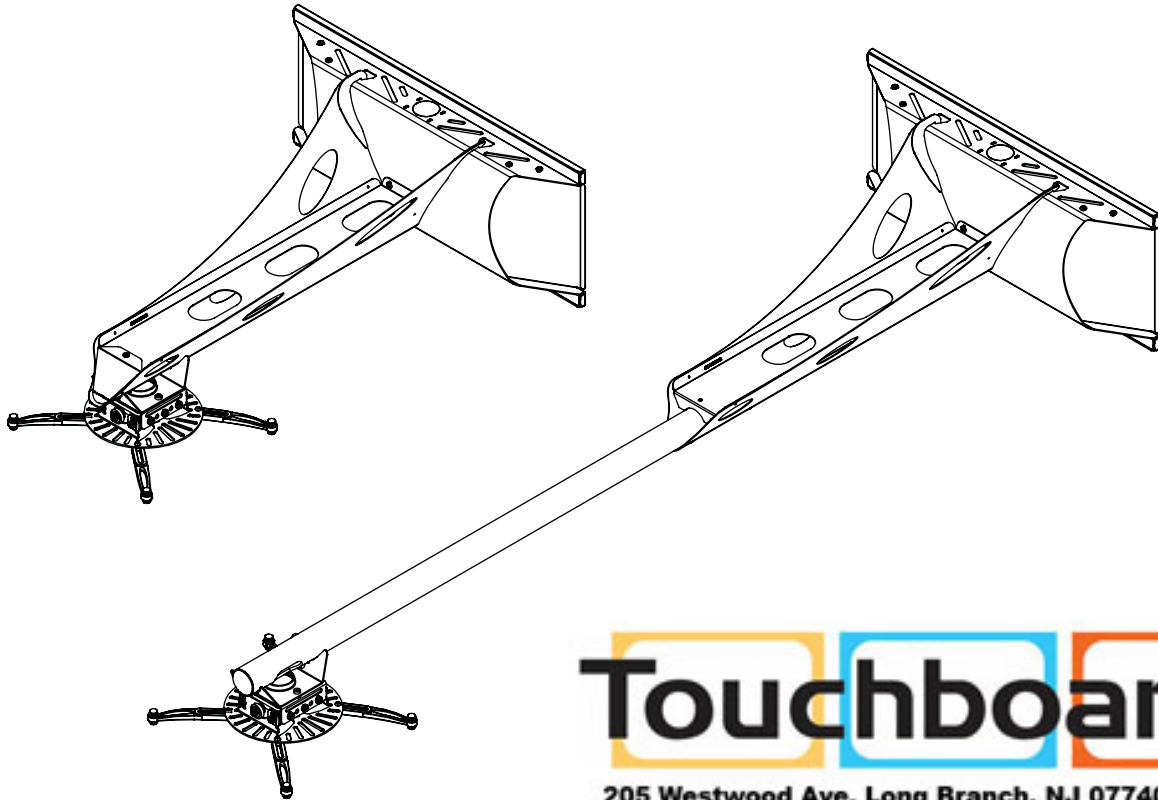

**Touchboards**

205 Westwood Ave, Long Branch, NJ 07740  
Phone: 866-94 BOARDS (26273) / (732)-222-1511  
Fax: (732)-222-7088 | E-mail: [sales@touchboards.com](mailto:sales@touchboards.com)

### UNI-ST/UNI-EXT Universal Short Throw Projector Arm

---

**NORTH AMERICA**  
3130 East Miraloma Avenue  
Anaheim, CA 92806 USA  
USA and Canada –  
Phone: 800-368-9700  
Fax: 800-832-4888

---

**EUROPE**  
Swallow House,  
Shilton Industrial Estate,  
Shilton, Coventry, England CV79JY  
Phone: +44 (0) 2476 614700  
Fax: +44 (0) 2476 614710



## Table of Contents

Warning Statements ..... 2

Parts List ..... 3

Installation Tools ..... 3

Determining the Installation Height ..... 4

Wood Stud Installation ..... 5

Solid Surface Installation ..... 6

Utilizing the Storage Feature ..... 7

Attaching the Projector Arm ..... 7

Throw Distance Calculation ..... 8

Upper Mounting Bracket Installation ..... 9

Extension Arm Installation ..... 10

Base Box Installation ..... 10

Cable Management ..... 11

Set Screw Installation (Optional) ..... 11

Technical Specifications ..... 12

Warranty ..... 13

### Warning Statements



PRIOR TO THE INSTALLATION OF THIS PRODUCT, THE INSTALLATION INSTRUCTIONS SHOULD BE READ AND COMPLETELY UNDERSTOOD. THE INSTALLATION INSTRUCTIONS MUST BE READ TO PREVENT PERSONAL INJURY AND PROPERTY DAMAGE. KEEP THESE INSTALLATION INSTRUCTIONS IN AN EASILY ACCESSIBLE LOCATION FOR FUTURE REFERENCE.



PREMIER MOUNTS DOES NOT WARRANT AGAINST DAMAGE CAUSED BY THE USE OF ANY PREMIER MOUNTS PRODUCT FOR PURPOSES OTHER THAN THOSE FOR WHICH IT WAS DESIGNED OR DAMAGE CAUSED BY UNAUTHORIZED ATTACHMENTS OR MODIFICATIONS, AND IS NOT RESPONSIBLE FOR ANY DAMAGES, CLAIMS, DEMANDS, SUITS, ACTIONS OR CAUSES OF ACTION OF WHATEVER KIND RESULTING FROM, ARISING OUT OF OR IN ANY MANNER RELATING TO ANY SUCH USE, ATTACHMENTS OR MODIFICATIONS.



THE SURFACE MUST BE CAPABLE OF SUPPORTING AT LEAST FIVE TIMES THE WEIGHT OF THE PROJECTOR. IF NOT, THE STRUCTURE MUST BE REINFORCED. THE MAXIMUM WEIGHT THAT CAN BE USED WITH THIS PRODUCT IS 75LBS. PROPER INSTALLATION PROCEDURE BY A QUALIFIED SERVICE TECHNICIAN, AS OUTLINED IN THE INSTALLATION INSTRUCTIONS, MUST BE ADHERED TO. FAILURE TO DO SO COULD RESULT IN SERIOUS PERSONAL INJURY, OR EVEN DEATH.



SAFETY MEASURES MUST BE PRACTICED AT ALL TIMES DURING THE ASSEMBLY OF THIS PRODUCT. USE PROPER SAFETY GEAR AND TOOLS FOR THE ASSEMBLY PROCEDURE TO PREVENT PERSONAL INJURY.



At least two qualified people should perform the assembly procedure. Injury and/or damage can result from dropping or mishandling the projector.



If mounting to studs, make sure that the mounting screws are anchored into the center of the studs. Use of an edge-to-edge stud finder is recommended.



Be aware of the mounting environment. If drilling and/or cutting into the mounting surface, always make sure that there are no electrical wires in wall. Cutting/drilling into an electrical line may cause serious injury.



Make sure there are no water lines inside the wall where the mount is to be located. Cutting/drilling into a water line may cause severe water damage to the mounting surface.



This product is intended for indoor use only. Use of this product outdoors could lead to product failure and personal injury.



Do not install near sources of high heat. Do not install on a structure that is prone to vibration, movement or chance of impact





Contact Premier Mounts with any questions  
(800) 368-9700  
techsupport@mounts.com





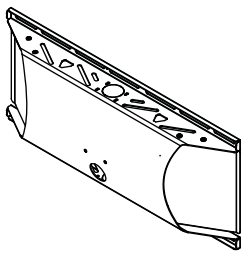
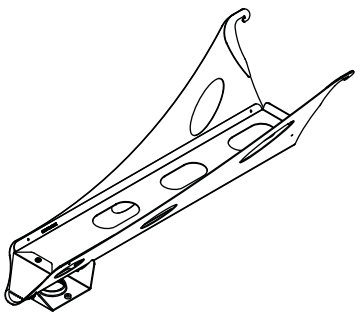
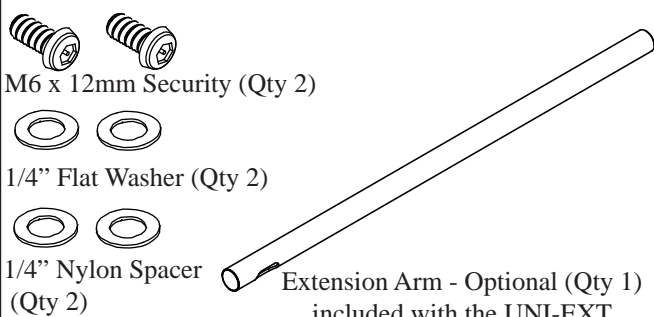
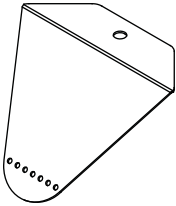
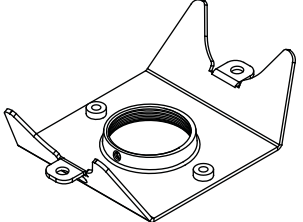
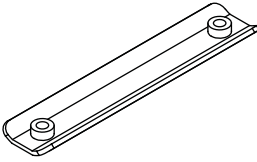
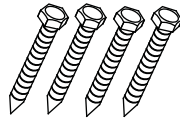
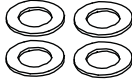

**Parts List**

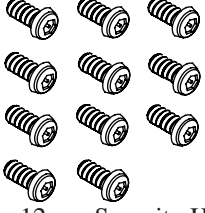
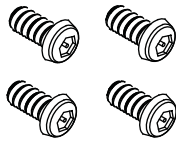
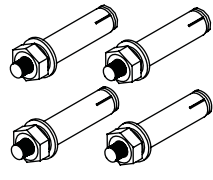
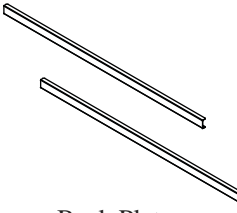
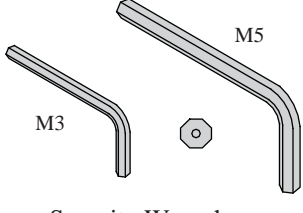
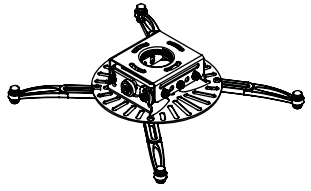

This mount is shipped with all proper installation hardware and components. Make sure that none of these parts are missing and/or damaged before beginning installation. If there are parts missing and/or damaged, please stop the installation and contact Premier Mounts (800) 368-9700.

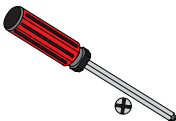
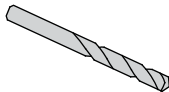
  Wall Plate (Qty 1)	 Arm Assembly (Qty 1)	<b>Extension Hardware Pack</b>  M6 x 12mm Security (Qty 2) 1/4" Flat Washer (Qty 2) 1/4" Nylon Spacer (Qty 2) Extension Arm - Optional (Qty 1) included with the UNI-EXT			
 End Cover (Qty 1)	 Upper Mounting Bracket (Qty 1)	 Inner Slide Plate (Qty 1)	 5/16 x 3" Lag Bolts (Qty 4)	 5/16 Flat Washers (Qty 4)	 Non-Security (Qty 1) Security (Qty 1) M6 Set Screws
 M5 x 12mm Security Head Screws (Qty 11)	 M6 x 12mm Security Head Screws (Qty 4)	 3/8" Concrete Wedge Anchors (Qty 4)	 Back Plate Covers (Qty 2)	 Security Wrenches (PDS-PLUS Hardware Pack)	
PDS-PLUS Projector Mount 					

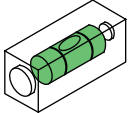
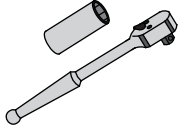
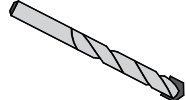
**Installation Tools (not supplied)**

	 Phillips Screwdriver	 1/4" Drill Bit	 Electronic Stud Finder	 Level
	 1/2" Socket and Socket Wrench	 3/8" Masonry Drill Bit	 Drill	



### Determining the Installation Height



**NOTE** In order to determine the installation height and throw distance, the PDS-PLUS projector bracket must be mounted to the projector. Please refer to the PDS-PLUS Installation Instructions prior to performing the following steps.



**NOTE** Refer to the projectors User's Manual to determine the offset of the projector lens to the top of the screen/whiteboard.

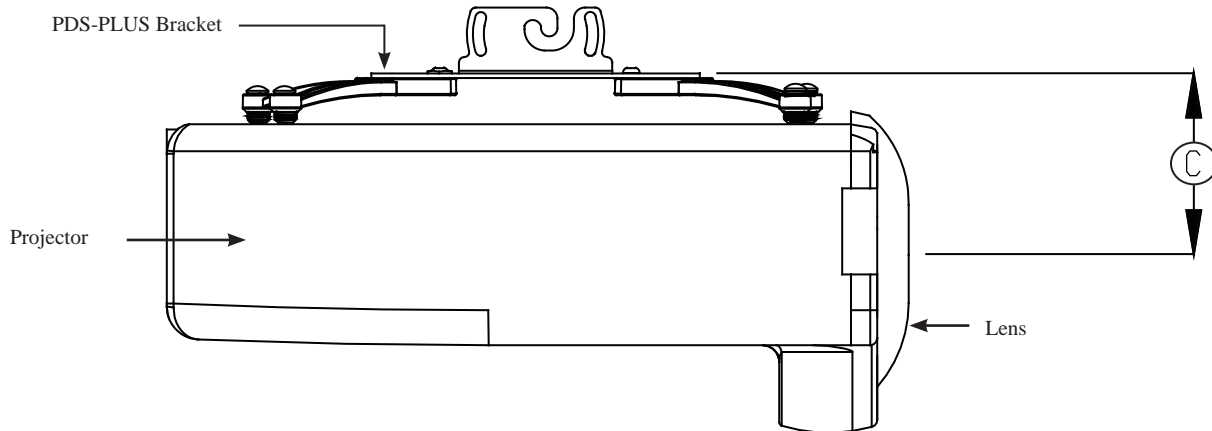

- Step 1.** Measure distance from center of lens to the top of the PDS-PLUS bracket.
- Step 2.** Add the distance from the ground to the top of the screen (A), the recommended offset from the projector manual (B), the measurement from Step 1 (C), and then add 1.5".  
(Example:  $A + B + C + 1.5'' = ?$ )
- Step 3.** Measure the calculated distance from the top edge of the viewable area of the screen/whiteboard and mark the wall. This mark will represent the lower edge of the wall plate.



Legend

- A -** Distance from ground to the top of the screen/whiteboard (viewable area).
- B -** Manufacturers recommended offset measurement. This measurement will be listed in the Users Manual.
- C -** Center of the lens to the top of the PDS-PLUS bracket.

Add 1.5" to the calculated total. This total distance will be the location for the bottom rail on the wall plate.



## Wood Stud Installation



Do NOT over-tighten lag bolts when attaching the mount to the wall. Improper installation may result in personal injury or damage to property.



DEAD CENTER MUST BE LOCATED ON THE STUD FOR CORRECT AND SAFE INSTALLATION.

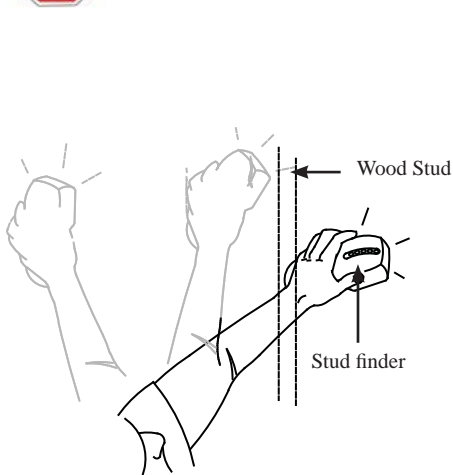

**Step 1.** Use an electronic stud finder (commercially available) to locate the center of the stud that is in the wall.

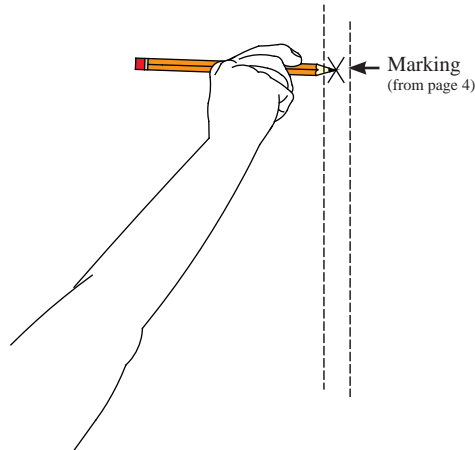

**Step 2.** Use a pencil to mark the first mounting hole, just above your height mark (from page 4).

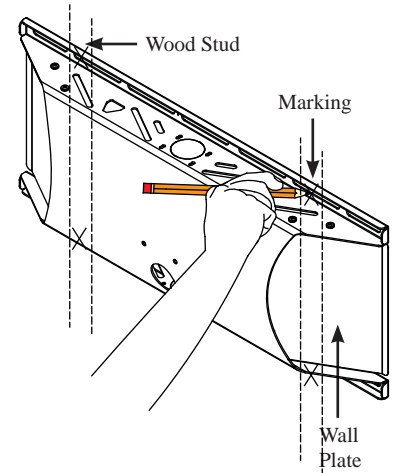

**Step 3.** Use the level to make sure the wall plate is level from top to bottom. After determining the desired viewing height, place the wall plate over the first hole and use a pencil to mark the rest of the holes.

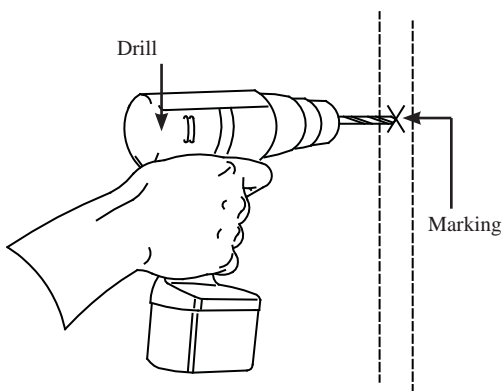

**Step 4.** Once the holes have been marked, use a 1/4" drill bit and portable drill to drill the pilot holes.

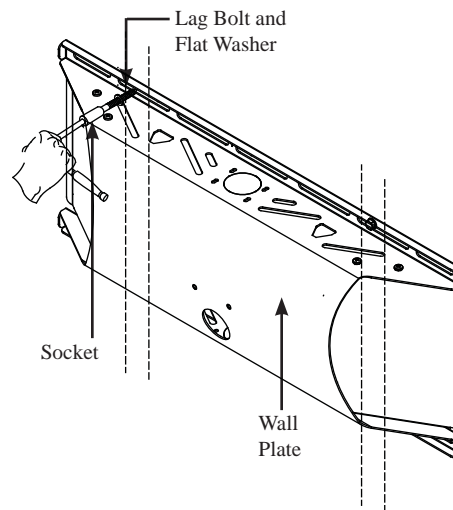

**Step 5.** After the pilot holes have been drilled, use four (4) 5/16" x 3" lag bolts and four (4) flat washers to mount the wall plate to the wooden stud. Use a 1/2" socket and socket wrench to finish this step.

**Step 6.** Insert and gently tap the wall plate covers into place.

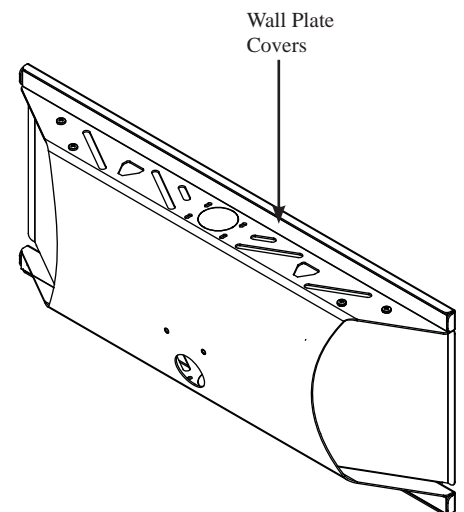

**Completed Installation**



### Solid Surface Installation

**NOTE** Concrete drill bits are commercially available.

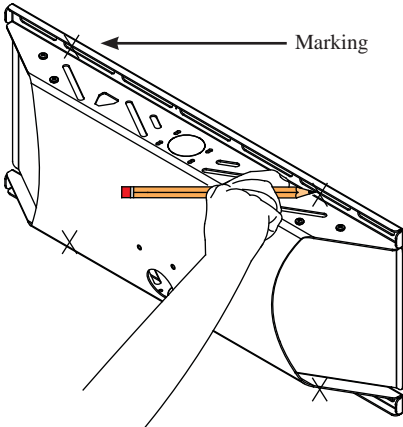

- Step 1.** Place the wall plate against the wall and use a level to make sure the wall plate is level from top to bottom.
- Step 2.** Use a pencil to mark the location of the mounting holes.

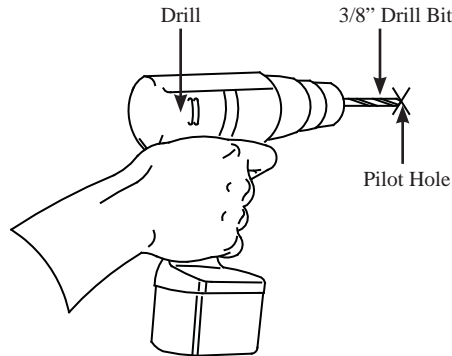

**Step 3.** Use a 3/8" drill bit to drill the mounting holes where the marks were made with a pencil.

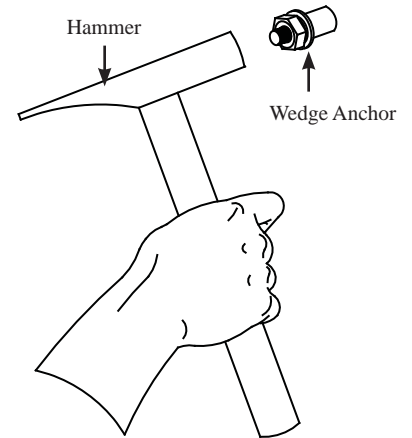

- Step 4.** Once the holes have been drilled, place the concrete wedge anchors into the hole. Using a hammer, gently tap into place.
- Step 5.** Once the wedge anchors have been inserted into the mounting holes, remove the nut and flat washer from the wedge anchor.

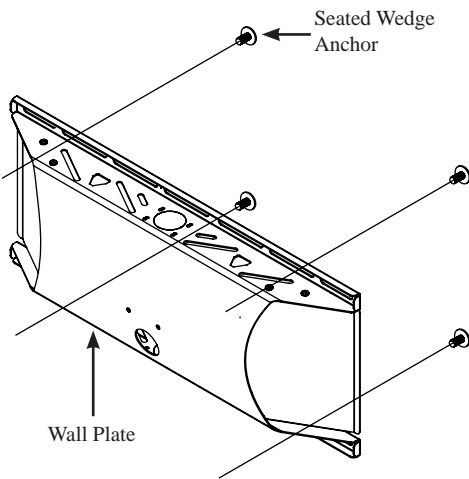

**Step 6.** Place the wall plate over the wedge anchors once the wedge anchors have been correctly inserted into the mounting surface.

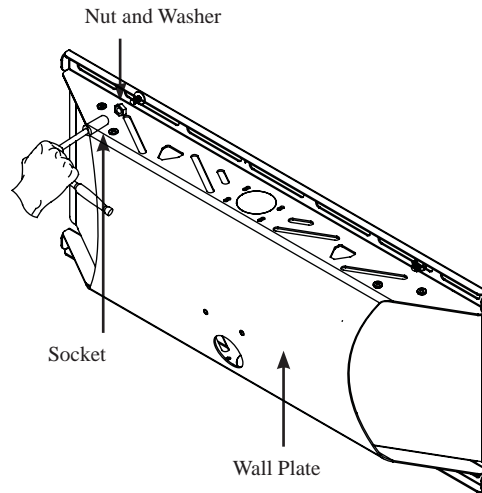

- Step 7.** Place the flat washer and nut onto the wedge anchor and tighten using a socket and socket wrench. Do not overtighten.
- Step 8.** Insert and gently tap the wall plate covers into place.

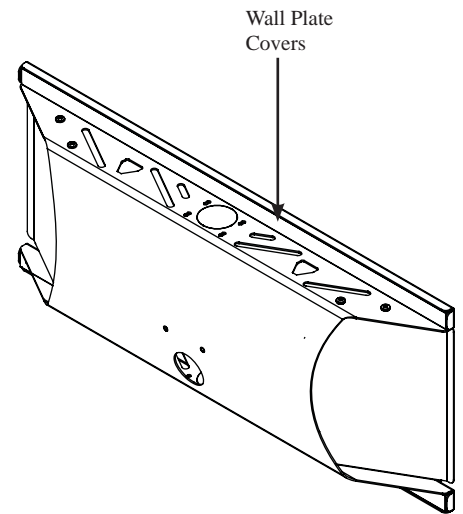

**Completed Installation**



## Utilizing the Storage Feature

The storage feature may be used to store electronic components. There is an accessible door on each side of the storage enclosure. It may be securely held shut with the use of four (4) M5 x 12mm security head screws. It may be easiest to pre-wire all cables down the arm (or extension) at this time (see Page 11).

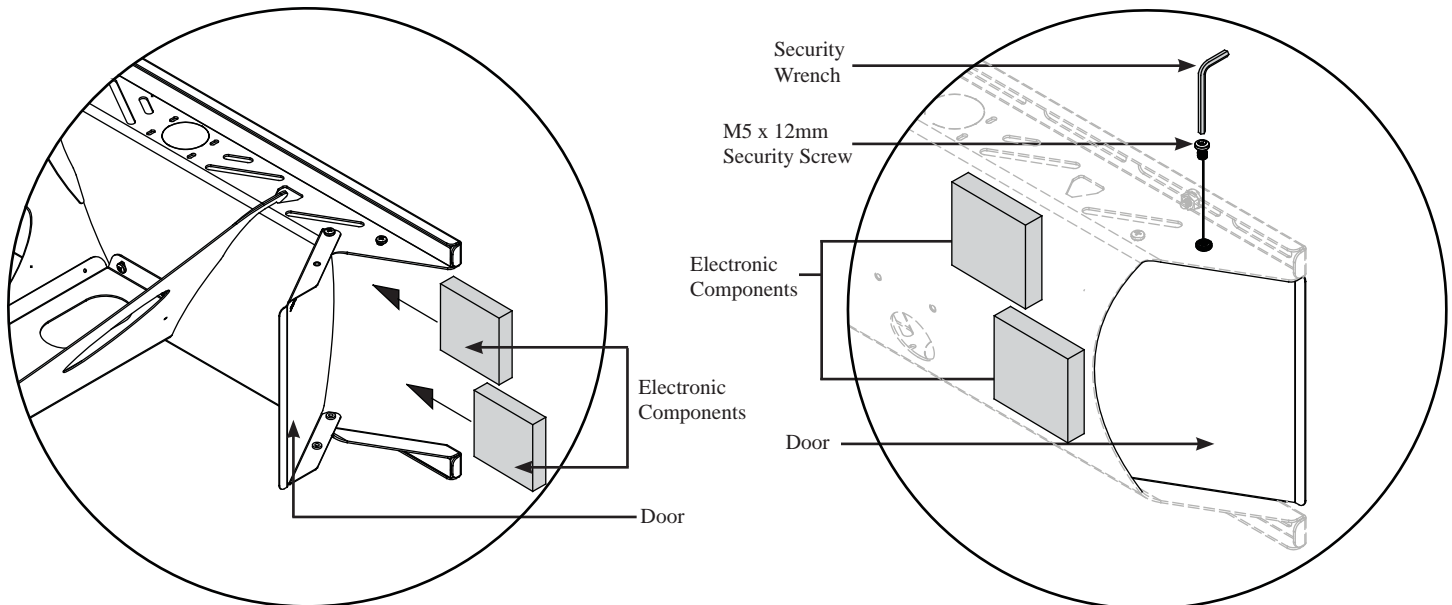

**Step 1.** Open the storage door that is located on the side of the wall plate.

**Step 2.** Place the electronic components inside the storage enclosure.

**Step 3.** Make all electronic connections at this time.

**Step 4.** Close the storage door and secure using two (2; 1 upper and 1 lower) M5 x 12mm security head screws. Tighten using a security wrench. Repeat this process for the other side as well.

## Attaching the Projector Arm

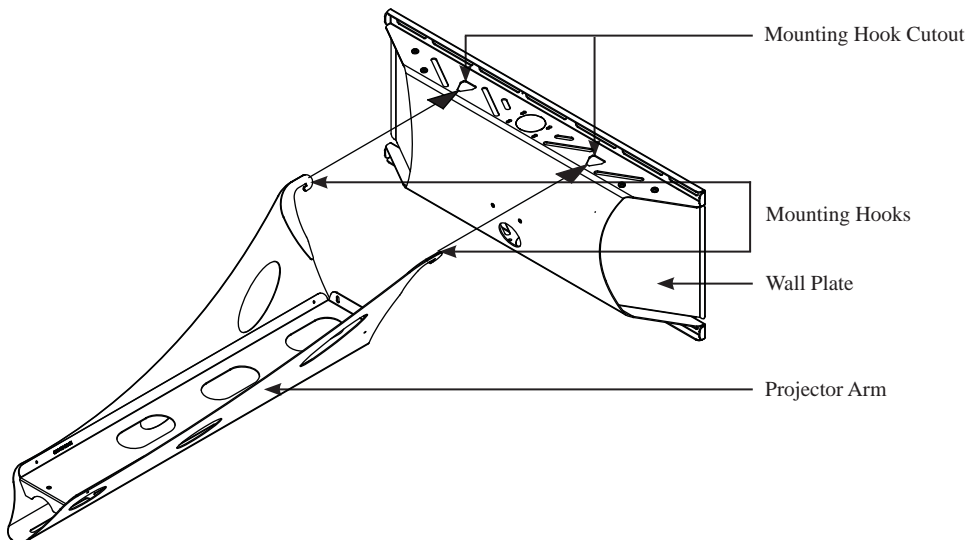

**Step 1.** Locate the mounting hook cutout on the top of the wall plate.

**Step 2.** Tilt the arm slightly and gently insert the mounting hooks into the mounting hook cutouts.

**Step 3.** Slowly lower and let the projector arm rest against the wall plate.



MAKE SURE THE PROJECTOR ARM IS FULLY SEATED BEFORE RELEASING THE UNIT.

WARNING

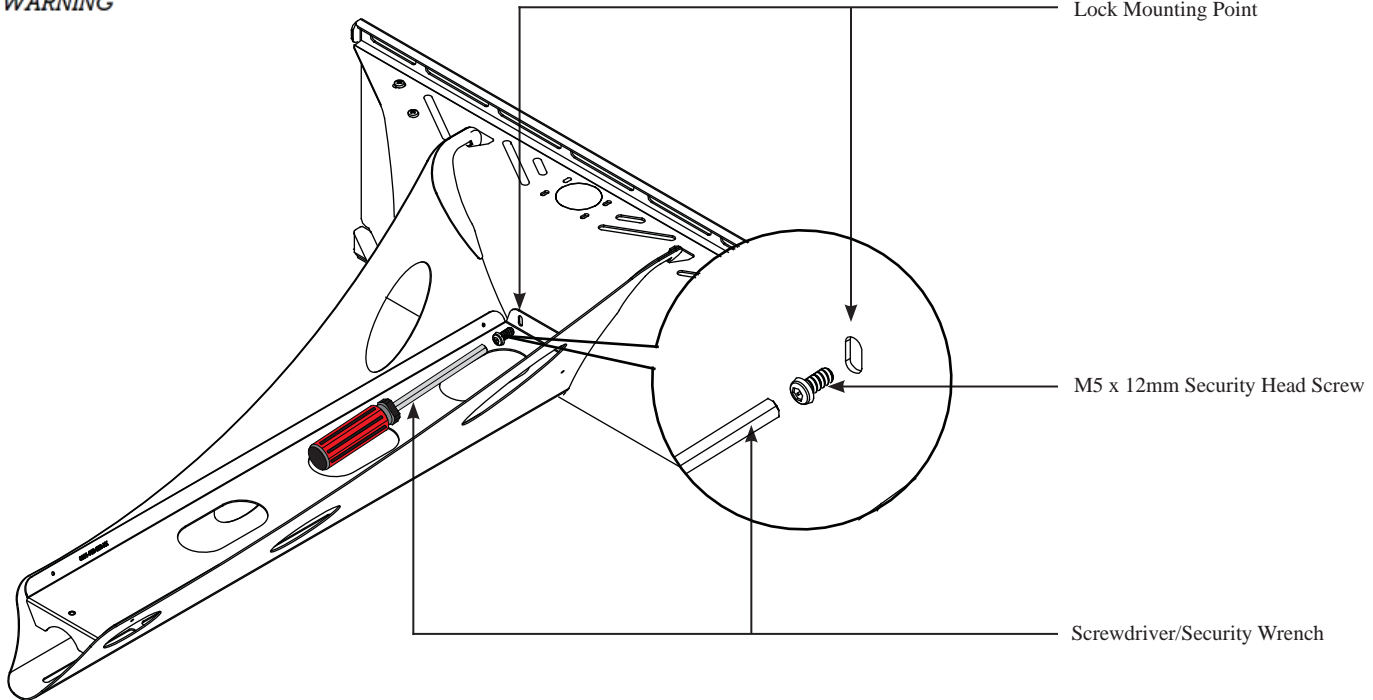

**Step 4.** Locate the two (2) lock mounting points on the projector arm. These two points will be aligned with the lock mounting points on the wall plate.

**Step 5.** Using a security wrench, insert and tighten two (2) M5 x 12mm security head screws.



DO NOT OVERTIGHTEN THE SCREWS.

WARNING

### Throw Distance Calculation



**NOTE** Please review the Operator's Manual that came packaged with your projector before attaching the upper mounting bracket. The correct throw distance (the distance from the projector to the screen) must be determined prior to mounting the projector.

**Step 1.** Refer to the projectors Users Manual to determine the distance from the lens to the front of the screen.

**Step 2.** Measure the distance from the front of the lens to the center of the PDS-PLUS (see diagram).

#### Front Mounted Lens

For front-mounted lenses, add distance (Y) to distance listed in projector Users Manual.

#### Rear Mounted Lens

For rear-mounted lenses, subtract distance (Y) from the distance listed.

**Step 4.** Use a tape measure to mark the appropriate distance on the UNI-STA/UNI-EXT. This will be where the center of the mounting bracket will be located.

#### Calculations

X = Manufacturers recommended throw distance

Z = Distance from wall to face of whiteboard/screen

Front Lens Throw Distance =  $(X + Y + Z)$

Rear Lens Throw Distance =  $(X - Y + Z)$

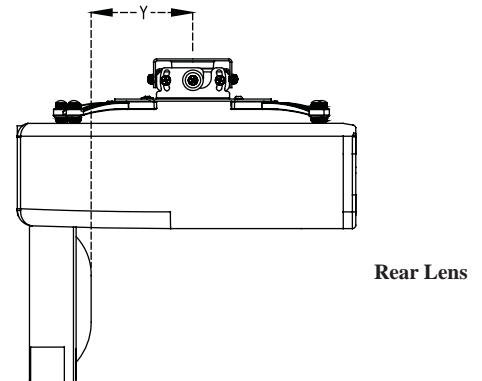
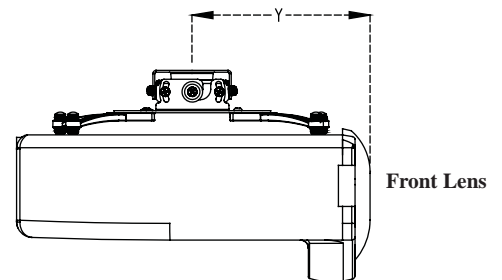

**NOTE** If installing UNI-EXT, please refer to Page 10 before continuing.





## Upper Mounting Bracket Installation

- Step 1.** Insert the inner slide plate into the projector arm.
- Step 2.** Determine which adjustment slot will be best for the projector placement.
- Step 3.** Raise the upper mounting bracket into position.
- Step 4.** Align the mounting holes of the upper projector plate with the mounting holes of the inner slide plate.
- Step 5.** Secure and finger-tighten two (2) M6 x 12mm security head screws.

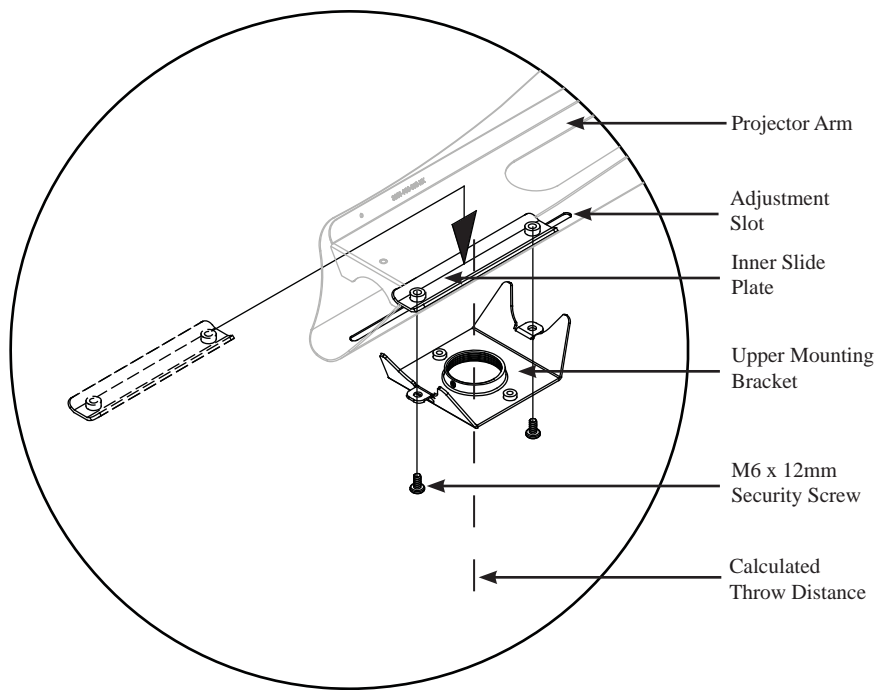

- Step 6.** Once the correct throw distance has been determined, use the security wrench (supplied) to tighten the mounting screws. Do not overtighten the screws.

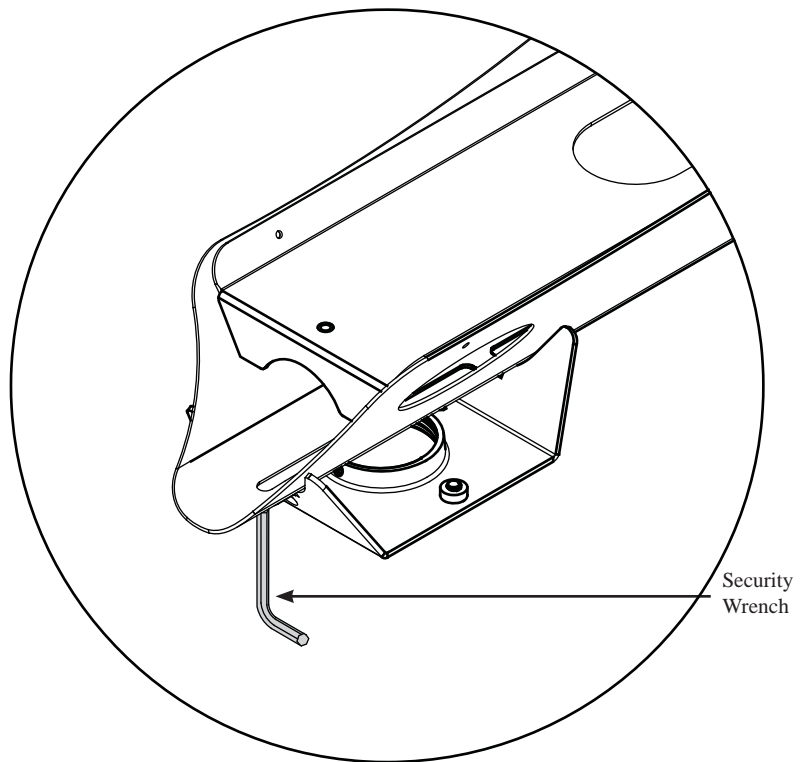



## Extension Arm Installation (Optional)



**NOTE** Please see the Operator's Manual to determine the correct throw distance (the distance from the projector to the screen) must be determined prior to mounting the projector.



**WARNING**

If the extension arm was purchased at a later date, the end cover must be removed prior to installing the extension arm.

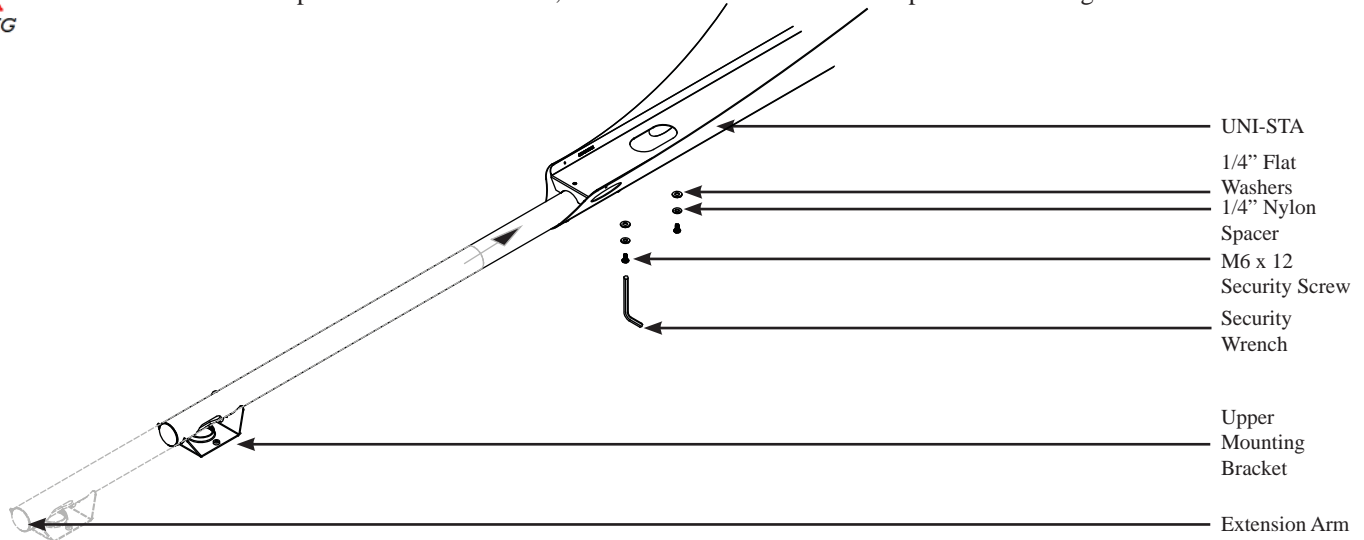

**Step 1.** Slide the extension arm into the open end of the UNI-STA (the front of the mount).

**Step 2.** Attach the upper mounting bracket directly to the extension using two (2) M6 x 12mm set screws (see page 8).

**Step 3.** Adjust length so that the center of the upper mounting bracket matches the throw distance calibration.

**Step 4.** Line up the mounting holes on the extension arm with the mounting slots on the UNI-STA.

**Step 5.** Using a screwdriver, insert and tighten two (2) M6 x 12mm security head screws, 1/4" flat washers and 1/4" nylon spacers.

**Step 6.** Attach the PDS-PLUS (see page 10).

## Base Box Installation



**NOTE** Please review the Operator's Manual that came packaged with the PDS-PLUS before attaching the PDS-PLUS to the upper mounting bracket.

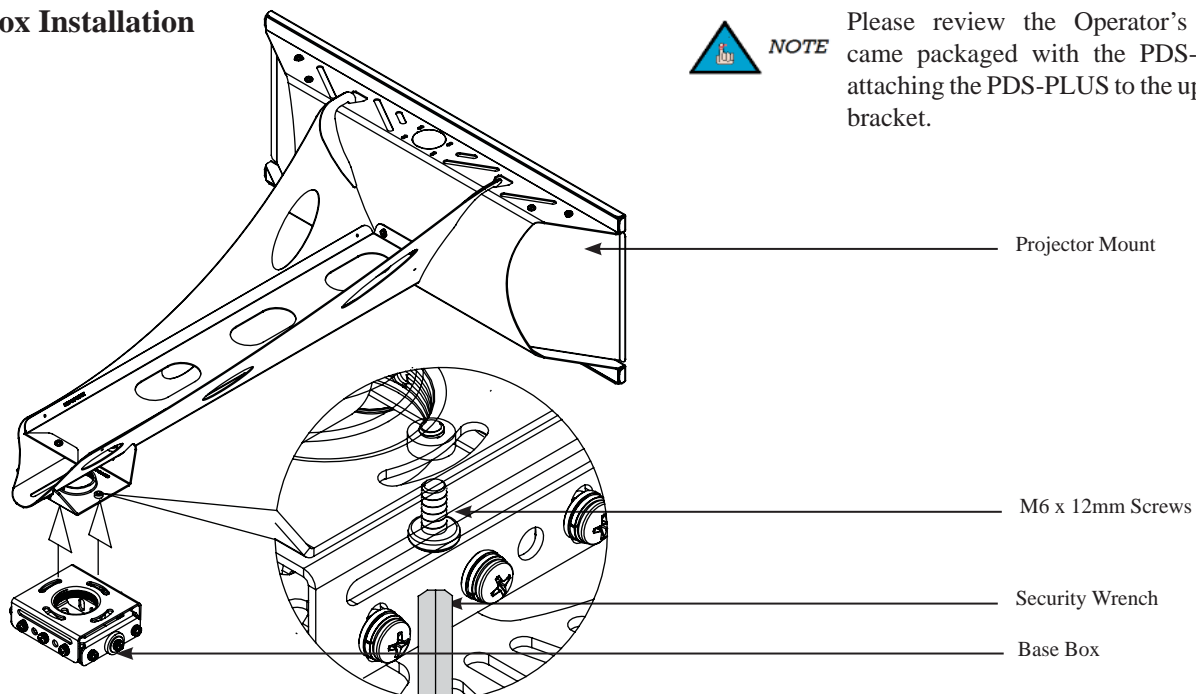

**Step 1.** Raise the base box projector mount to the upper mounting bracket.

**Step 2.** Align the two (2; one each side) mounting holes.

**Step 3.** Using a screwdriver/security wrench, insert and tighten two (2) M6 x 12mm security head screws. Do not over tighten the screws.

**Step 4.** Attach the projector to the base box, referring to the PDS-PLUS Installation Instructions for final adjustments.



## Cable Management

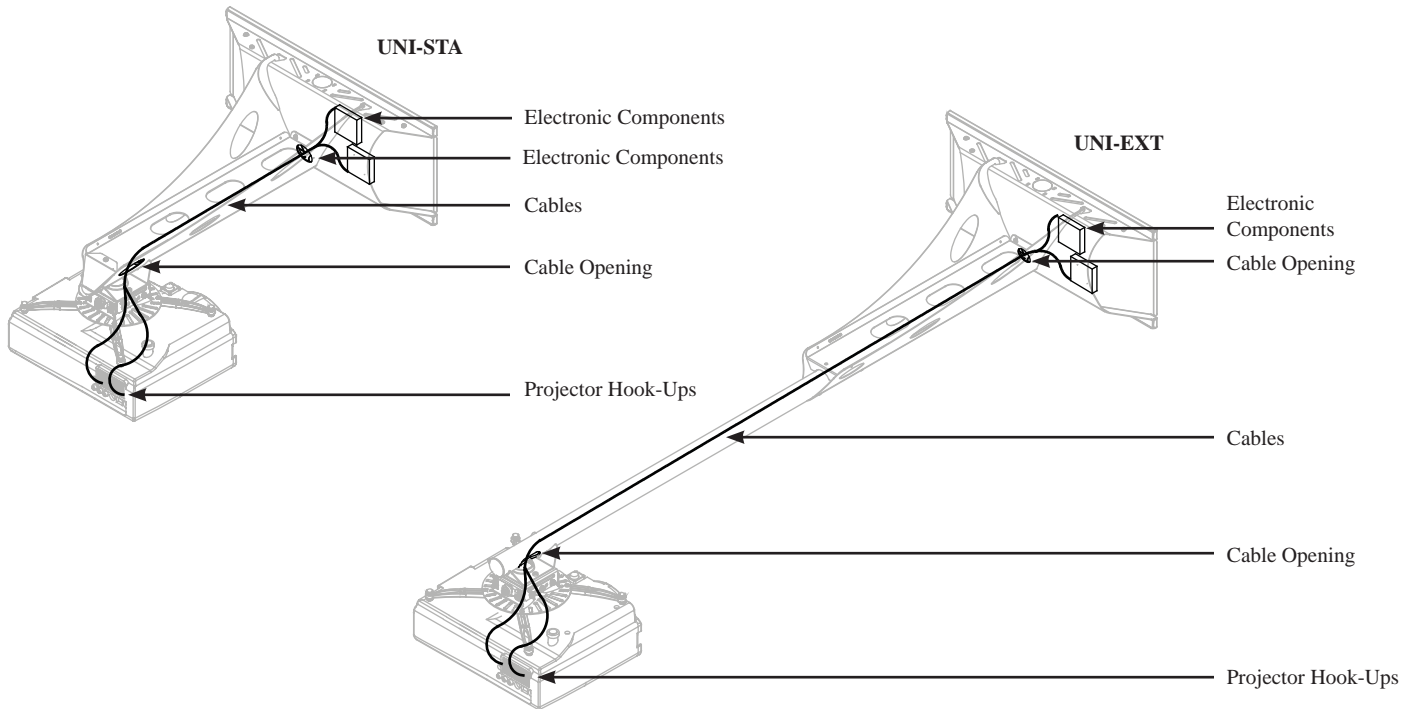

**Step 1.** The cable access holes are located at the end of the short throw mount and on the wall plate.

**Step 2.** Route the cables through one end of the UNI-STA/UNI-EXT and out the other end.

## Set Screw Installation (Optional)

The M6 set screw will be used in conjunction with any standard 1-1/2" NPT or CLS (sold separately).

**Step 1.** Thread in CLS or any 1-1/2" NPT until securely fastened.

**Step 2.** Thread in one (1) M6 x 6mm set screw.

**Step 3.** Use an M3 security wrench to tighten the M6 set screw (included in the PDS-PLUS hardware).

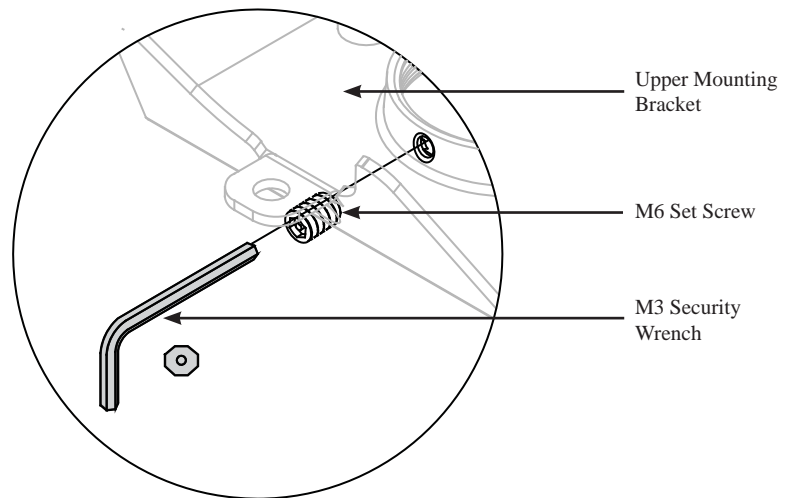



### Technical Specifications

All measurements are in inches(mm).

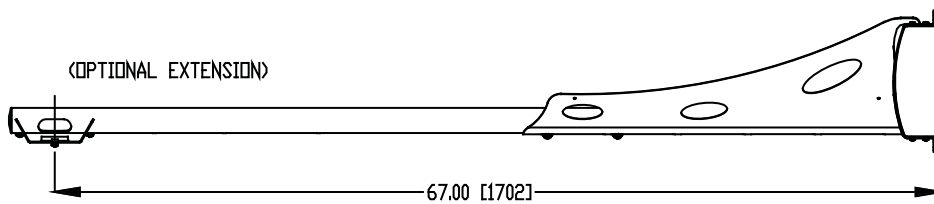
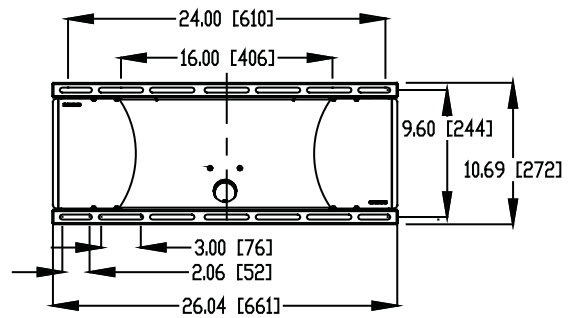
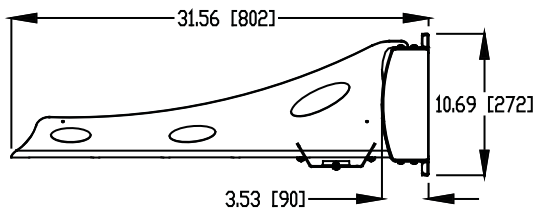
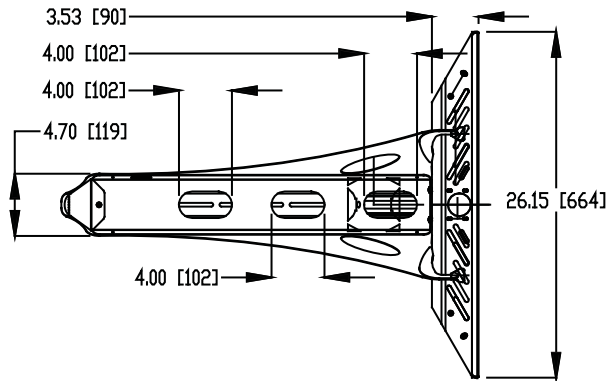

MAXIMUM DISTANCE FROM WALL

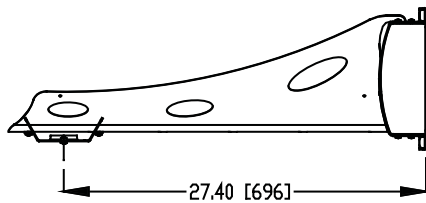

MINIMUM DISTANCE FROM WALL

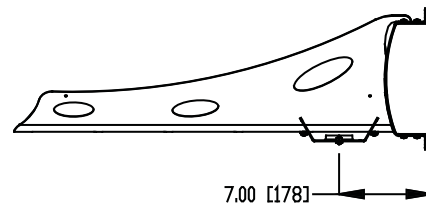



## Warranty

### PREMIER MOUNTS LIMITED LIFETIME WARRANTY

#### What and Who is Covered by this Limited Warranty and for How Long

Premier Mounts warrants this product to be free from defects in material and workmanship for the lifetime of the original owner of this product. The limited warranty is valid only for the original purchaser of the product.

#### What Premier Mounts Will Do

At the sole option of Premier Mounts, Premier Mounts will repair or replace any product or product part that is defective. If Premier Mounts chooses to replace a defective product or part, a replacement product or part will be shipped to you at no charge, but you must pay any labor costs.

#### What is Not Covered; Limitations

PREMIER MOUNTS DISCLAIMS ANY LIABILITY FOR DAMAGE TO MOUNTS, ADAPTERS, DISPLAYS, PROJECTORS, OTHER PROPERTY, OR PERSONAL INJURY RESULTING, IN WHOLE OR IN PART, FROM IMPROPER INSTALLATION, MODIFICATION, USE OR MISUSE OF ITS PRODUCTS.

PREMIER MOUNTS DISCLAIMS ALL OTHER WARRANTIES, EXPRESS OR IMPLIED, INCLUDING WARRANTIES OF MERCHANTABILITY AND FITNESS FOR A PARTICULAR PURPOSE. PREMIER MOUNTS IS NOT RESPONSIBLE FOR INCIDENTAL OR CONSEQUENTIAL DAMAGES, INCLUDING BUT NOT LIMITED TO, INABILITY TO USE ITS PRODUCTS OR LABOR COSTS FOR REMOVING AND REPLACING DEFECTIVE PRODUCTS OR PARTS. SOME STATES DO NOT ALLOW THE EXCLUSION OR LIMITATION OF INCIDENTAL OR CONSEQUENTIAL DAMAGES, SO THE ABOVE LIMITATION OR EXCLUSION MAY NOT APPLY TO YOU.

#### What Customers Must Do for Limited Warranty Service

If you discover a problem that you think may be covered by the warranty you MUST REPORT it in writing to the address below within thirty (30) days. Proof of purchase (an original sales receipt) from the original consumer purchaser must accompany all warranty claims. Warranty claims must also include a description of the problem, the purchaser's name, address, and telephone number. General inquiries can be addressed to Premier Mounts Customer Service at 1-800-368-9700. Warranty claims will not be accepted over the phone or by fax.

Premier Mounts  
Attn: Warranty Claim  
3130 East Miraloma Ave.  
Anaheim, CA 92806

#### How State Law Applies

THIS WARRANTY GIVES YOU SPECIFIC LEGAL RIGHTS, AND YOU MAY ALSO HAVE OTHER RIGHTS WHICH VARY FROM STATE TO STATE.



205 Westwood Ave, Long Branch, NJ 07740  
Phone: 866-94 BOARDS (26273) / (732)-222-1511  
Fax: (732)-222-7088 | E-mail: sales@touchboards.com