



EAGLE X

XTENDED LIFE COMBUSTION & SYSTEM ANALYZERS™



Eagle & Eagle X Owners Manual



XTENDED LIFE
CO SENSOR

THIS CHANGES EVERYTHING

EAGLE & EAGLE X OVERVIEW

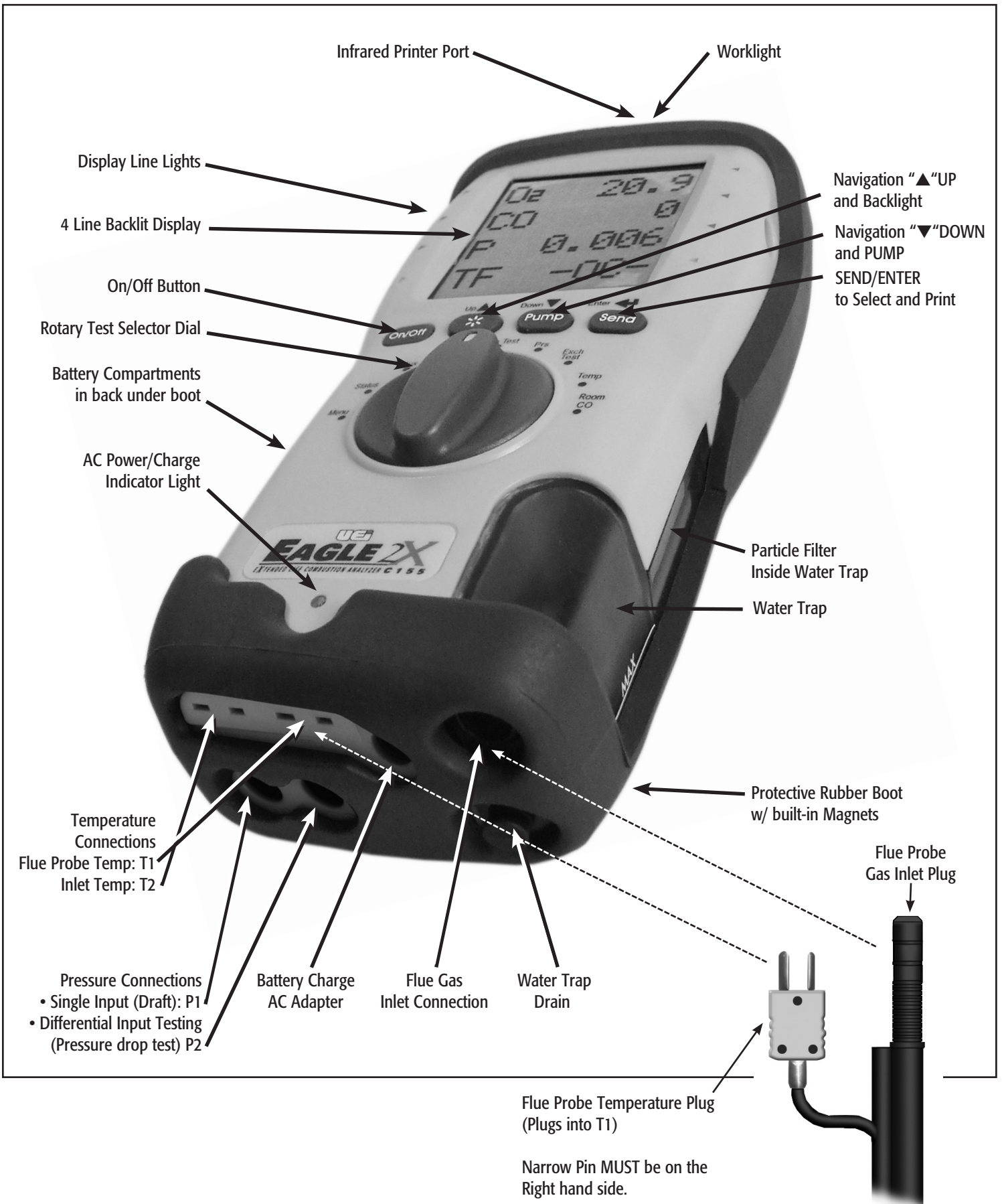

Infrared Printer Port

Worklight

Display Line Lights

4 Line Backlit Display

On/Off Button

Rotary Test Selector Dial

Battery Compartments in back under boot

AC Power/Charge Indicator Light

Navigation "▲" UP and Backlight

Navigation "▼" DOWN and PUMP

SEND/ENTER to Select and Print

Particle Filter Inside Water Trap

Water Trap

Protective Rubber Boot w/ built-in Magnets

Temperature Connections
Flue Probe Temp: T1
Inlet Temp: T2

Flue Probe Gas Inlet Plug

Pressure Connections
• Single Input (Draft): P1
• Differential Input Testing (Pressure drop test) P2

Battery Charge AC Adapter

Flue Gas Inlet Connection

Water Trap Drain

Flue Probe Temperature Plug (Plugs into T1)

Narrow Pin MUST be on the Right hand side.

DISPLAY PARAMETERS ON UEI COMBUSTION ANALYZERS

- TF = **Flue Temperature:** Calculate net temperature in °F or °C.
 - Shows ambient temp after fresh air calibration and '- □ □ -' when probe is disconnected.
- T = **Net Temperature:**
 - Differential of flue temperature minus ambient (or inlet) temperature
 - Differential of T1 - T2
- TΔ = **Temperature Differential:**
- O2 = **Oxygen:** O2 percentage displayed
- CO = **Carbon Monoxide:** CO ppm (parts per million) displayed.
 - '- - - -' or '- □ □ -' is displayed if there is a fault with the CO sensor or the instrument has not been zeroed correctly, switch off instrument and try again.
- CO2 = **Carbon Dioxide:**
 - EAGLE (C125 & C127) Calculated from the fuel selected and the measured O2 level
 - EAGLE (C125 & C127) Will display '- - - -' or '- □ > -' if the O2 level is too high to calculate CO2 or in fresh air.
 - Calculated value is only displayed during the combustion test.
 - EAGLE X (C155 & C157) Direct measurement CO2 ppm (parts per million) displayed.
- X = **Excess Air:**
 - Indicated as 'XAIR %' on the printout
 - A calculated percentage of O2 above the theoretical level required for complete combustion.
 - Is required to completely burn the fuel due to poor mixing and assisting in venting flue gases
 - Only displays a reading during combustion test.
 - '- - - -' or '- □ > -' is displayed in fresh air.
- EFF = **Efficiency:**
 - Calculated based on gas readings, net temperature and fuel selected.
 - Value is combustion efficiency, not appliance efficiency.
- Δ = **Loss:**
 - Total losses calculated from Combustion Theory. A summation of the next three parameters
 - Dry %: Calculated heat lost turning the Carbon in the fuel to Carbon Dioxide (CO2)
 - Wet %: Calculated heat lost turning the Hydrogen in the fuel into water (H2O)
 - CO Loss %: Calculated loss due to partially burnt Carbon.
 - Any CO in the flue has the potential to be turned into CO2 releasing and losing more heat up the flue.
- COA = **Carbon Monoxide Air-Free:** Referenced to an oxygen level of 0%.
 - **Do not confuse this reading with the actual CO reading** as detailed above.
 - See the Combustion Efficiency Calculation sections for more details.
- AIRB = **Air Inlet:**
 - Temperature used to calculate the NET temperature.
- CO/CO2 = **CO/CO2 Ratio:** The ratio of measured CO divided by CO2.
 - It gives an indication of:
 - How good a gas sample the instrument is reading.
 - How clean the boiler is running.
 - Example: A new or clean domestic boiler will display a ratio of less than 0.004, a unit in need of cleaning 0.004 - 0.008 and a unit needing a major overhaul will show at least 0.008.
 - Only displays a reading during combustion test. '- - - -' is displayed while in fresh air.
- □ = **Draft Pressure**
- P = **Pressure**
- NO = **Nitric Oxide:**
- -PO- = **Pump Off:**
 - Measured gases will display this when pump is off.
- -□> = **High O2 level:**
 - Calculated values will display this when O2 levels are greater than 18%
 - Values are calculated with fuel choice and the O2 readings
- -□□- = **Probe Not Connected:**
 - Temperature values will display this when the probe is not connected or is open
 - Press and hold the "PUMP" button to Zero the pressure sensor in selector positions that display measured or calculated values "Aux" & "Flue Test".
- N/F = **Not Found:**
 - Displayed when not available or not installed ie: NO on a C155 or C125.

NOTE: See page 8 for complete auxiliary display listings.

Getting Started

SAFETY NOTES



Before using this meter, read all safety information carefully.
“WARNING” is used to indicate conditions or actions that may pose physical hazards to the user.
“CAUTION” is used to indicate conditions or actions that may damage this instrument.



WARNING!

This analyzer extracts combustion gases that may be toxic in relatively low concentrations. These gases are exhausted from the back of the instrument. This instrument must only be used in well-ventilated locations. It must only be used by trained and competent persons after due consideration of all the potential hazards.

PREFLIGHT CHECKLIST

- Clean particle filter
- Water trap and probe line are empty of water
- Power on and zero
- All hose and thermocouple connections are properly secured
- Flue gas probe is sampling ambient FRESH air
- Water trap is fitted correctly to the instrument
- Flue temperature plug is connected
- Inlet temperature probe is connected if required
- Setting Inlet Temperature
 - Turn on and zero the analyzer with out the flue probe connected to use ambient temperature
 - Connect flue probe thermocouple to T1 during zero countdown to store probe tip temperature as inlet (ducted system)

ANALYZER CONNECTIONS

NOTE: Take care when inserting the temperature probes as the pins are polarized. Insert with the smaller pin (+) to the right.



WARNING!

Turning the pump off while the probe is in the flue will leave toxic gases inside the analyzer. Once data has been printed or copied it is advisable to purge the unit with fresh air as soon as possible. Use the GAS ZERO function (Eagle X only) to purge the analyzer of excess gases. To do this on a standard Eagle remove the probe from the flue and turn ON the pump. Always allow the readings to return to zero (20.9 for O₂) prior to shutting the unit off. The meter will not switch off until the CO reading is below 20 ppm.



WARNING!

The probe will be hot from flue gases. Remove the probe from the flue and allow it to cool naturally. Do not immerse the probe in water, as this will be drawn into the analyzer and damage the pump and sensors. Once the probe is removed from the flue and the readings have returned to ambient levels hold down “On/Off” and switch off the analyzer. The instrument will count down from 30 to switch off. If you pressed “On/Off” by mistake, pressing “Send” will return you to normal operation.

POST FLIGHT

- (1) Remove the probe from the flue and allow the analyzer to purge with fresh air until readings return to zero.
 - O₂ to 20.9%, CO to Zero (*Be careful as the probe tip will be HOT*)
- (2) Drain water trap
- (3) Check particle filter



Drain water trap by unplugging the drain plug and shake to get excess water out.



Check particle filter for dirt and any other sediment and replace if necessary.

QUICK START GUIDE .



GETTING STARTED



Turn Power on in area of fresh air and allow to countdown

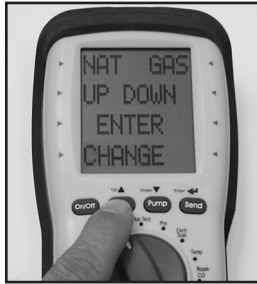

Rotate test selector to Fuel. Press "▲"UP or "▼"DOWN to scroll and select desired fuel. Top line is selected fuel.



Connect flue probe thermocouple connector to T1, and connect flue probe to water trap as shown above. Use optional probe with T2 for inlet temperature.

WORKLIGHT AND DISPLAY



After the Analyzer has zeroed turn test selector to appropriate test screen. Press "▲"UP at any point to turn on the backlit display and worklight. NOTE: backlight does not work in the fuel menu or during purge.

GAS ZERO (EAGLE X SERIES ONLY)

Re-Zero the analyzer in fresh air if needed for different fuel type or after large temperature rise.



Rotate test selector to Menu.

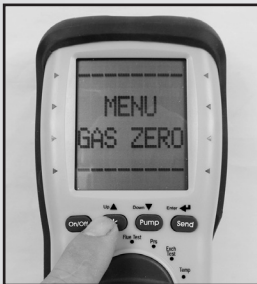

Press "▲" UP Button to GAS ZERO and press ENTER.



Make sure Analyzer is in fresh air and press ENTER.

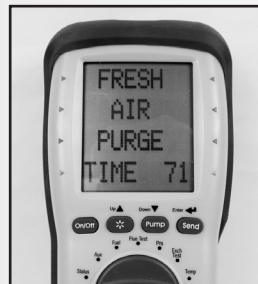

Analyzer will then Zero This takes 90 seconds.

NOTE: The Eagle X will automatically initiate Gas Zero if required for continued accurate results.

BASIC CO/COMBUSTION ANALYSIS

Best results are obtained at Steady State Efficiency (SSE). Allow equipment adequate warm-up time prior to testing.

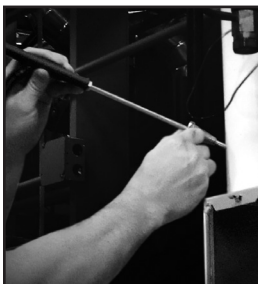

Insert Flue Probe in stack. Adjust the cone so the end of the probe is approximately at the center of the stack (4" stack adjust cone to approx 2" from end of probe.)



Rotate test selector to "Flue Test" and begin testing.



Press and Hold the "▲" UP button to toggle between fuel test screens 1 and 2. Flue Test Pg.1: O2, CO, Draft (P) and TF. Flue Test Pg. 2: CO2, NO, Efficiency and Excess Air. (NO: upgrade available on Eagle 2 and 2X. NO: comes standard on Eagle 3 and 3X.)



Make any adjustments as needed for proper combustion and wait for analyzer to display any change in the readings. (repeat if necessary)



Once complete, remove probe from the stack and allow the analyzer to purge in fresh air until CO sensor readings return to ZERO and O2 reads 20~21% (20.9%). Continue to the next test or turn off your analyzer if finished. NOTE: print and store functions may be used at any point during testing.

NOTE: you will have to drill a hole at least 3/8". Use a high temp silicone to seal after testing.

DIFFERENTIAL TEMPERATURE TEST

This test is useful for quick checks of temperature rise, and differential/delta T along with other HVAC temperature applications.

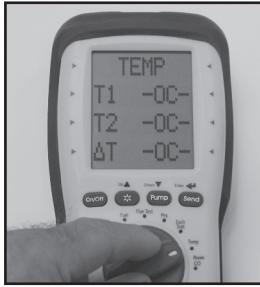

Rotate test selector to Temp



Connect flue probe thermocouple or accessory thermocouple connector to T1. Connect accessory thermocouple probe to T2. Compatible with any K-Type thermocouple probe or clamp.

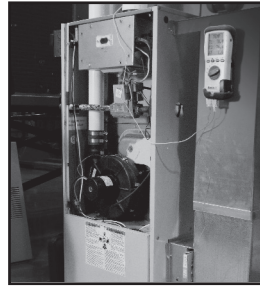

Place thermocouples in test locations to start testing.



Observe T1, T2 and Differential/delta T.



Press "SEND" to print results or hold "SEND" to Log.

HIGH RESOLUTION MANOMETER DRAFT & STATIC PRESSURE TEST

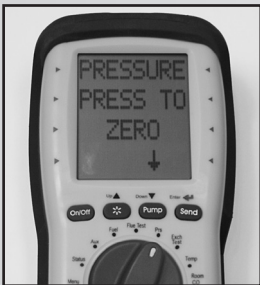

Rotate test selector to Prs (Pressure)

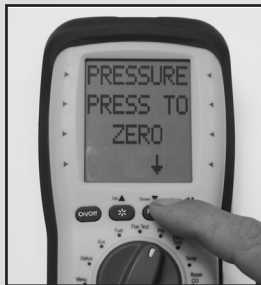

Press and hold "▼" DOWN button to zero pressure sensor.



Connect true draft hose and probe into P1. Use P2 for Differential. Place probe tip in stack to measure draft. Connect static pressure hose to P1 and P2 to measure differential pressure..



Place true draft hose and probe tip in flue to measure draft. You can also use the combustion draft probe for measuring pressure.



Press "SEND" to print results or hold "SEND" to Log.

PRINTING AND STORING RESULTS

Combustion Flue Testing, Pressure (Draft) Differential or Temperature Testing selector positions

Print and Log easily from the following test screens: Flue test, Pressure/Draft/Differential, temperature and Auxiliary (Eagle X only).

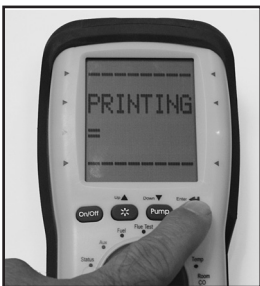

Press "SEND" to start the printout of results from any test screen.

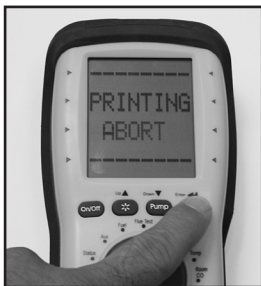

Press "SEND" again during printing to cancel.



Press and hold "SEND" to log the current readings.

PRINTING LOGGED RESULTS

To view logged results rotate the test selector to "MENU" scroll to the "REPORT" screen and select desired test. Select "VIEW" and scroll to desired log and view results. Press "SEND" to print.

HIGH CO ALERT

At 400PPM CO the screen will display HIGH CO and the indicator light will flash and analyzer will beep several times. Above 2000PPM Screen will display HIGH CO REMOVE PROBE, the indicator light will flash and pump will pulse. Press SEND/ENTER to continue testing or remove probe to allow analyzer to purge.

CO ROOM TEST

Great for checking for ambient CO and back drafting situations.



No probes or hose connections required for this test. Place handset in the area to be tested. Rotate test selector to Room CO



Press the PUMP button to start the test. CO readings will be logged every 2 minute for a 30 minute time span



To view results rotate test selector to "MENU" and select "REPORT" Scroll to "ROOM CO" and press "SEND".



Press "SEND" to VIEW results.



Press "SEND" again to print.

HEAT EXCHANGER TEST

There are many methods to test heat exchanger integrity. One of these is to observe the Excess Air, O₂ and CO readings both before and after the blower turns on. If the heat exchanger is sealed your O₂ and CO readings should remain fairly stable. A breach in the heat exchanger may allow fresh air to be forced into the flue after the blower turns on due to a pressure increase in the plenum. The result may be a rise in the measured O₂ in the stack gas and an increase in the Excess Air. In some sealed systems the fresh air drawn in through the breach may reduce the combustion air available leading to an increase in the CO reading. If either of these situations are present it is probable that there is a problem with the Heat Exchanger which may require additional testing and inspection.

NOTE: Many cracks are invisible to borescopes or the naked eye, and only open or separate from pressure or temperature changes during operations.



Rotate test selector to Exch Test. Call for heat on the system. Observe and wait for O₂ readings to stabilize.



Prior to the blower turning on, and after readings have stabilized, press the SEND button. This will store the Pre-Blower test segment.

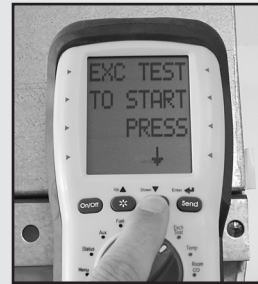

After the blower turns on press PUMP to start the Post-Blower test.

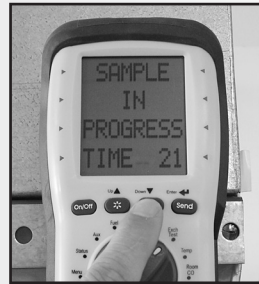

The meter will wait 30 seconds and then record the Post-Blower values for CO, O₂ and Excess Air. Test results will automatically be stored to exchange reports. Report includes both Pre and Post Blower test segments.



To view test results rotate test selector to "MENU" go to the "REPORT" screen and select EXCH. Select "VIEW" and scroll to desired log. Press "SEND" to print.

AUX SETTING

Programmable Auxiliary screen allows for Tech selectable test parameters to be chosen.



Rotate test selector to "MENU" scroll "▲"UP or "▼"DOWN to SCREEN. Press "SEND".



Scroll "▲"UP or "▼"DOWN to AUX. Press "SEND".

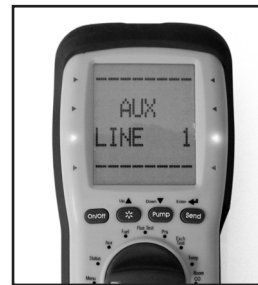

Scroll "▲"UP or "▼"DOWN to select the LINE you wish to change. Press "SEND". (LINE 1 shown)

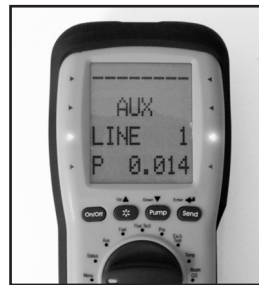

Scroll "▲"UP or "▼"DOWN to select the function you wish to display. Press "SEND". (Pressure shown)

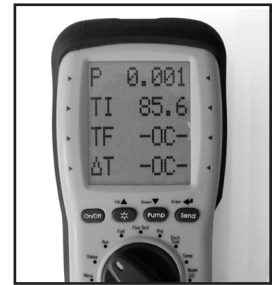

Rotate selector to "AUX" to view. Pressure is now shown in line 1 along with T₁, T₂ and Differential/delta T.

MAIN MENU NAVIGATION

Use the "▲"UP or "▼"DOWN buttons to scroll through the MAIN MENU or OPTIONS. Press "SEND" to select displayed screen choice. NOTE: Rotate the selector off menu at any time to EXIT. Selections will NOT be saved unless you press "SEND"

PRESS "▲"UP to scroll through menu items in this order.

MAIN MENU	press "▲" SUB MENU	press "▲" OPTIONS	Notes
SETUP	SET TIME		Use to set current time.
	SET DATE		Use to set current date.
	C < - - > F	°F or °C	Use to select temperature scale.
	LANGUAGE	ENGLISH FRENCH SPANISH	Use to select language.
	EXIT		Return to main menu.
GAS ZERO (EagleX ONLY)	RESET GAS ZERO		Press "SEND" to start. Automatically returns to main menu.
PRESSURE	SMOOTH	ON/OFF	Use to change screen update rate.
	RESOLVE	HIGH LOW	Use to select display resolution.
	PS UNITS	In H2O mbar mmH2O Pa kPa PSI mmHg hPa	Use to select desired unit of measure. Choose between: inches H2O (water gauge) millibar millimeters of H2O Pascals Kilopascals Pounds per square inch Millimeters of mercury Hecto pascals
	EXIT		Return to main menu.
REPORT	COMB'N PRESSURE EXCH TEMP ROOM CO	VIEW DEL ALL	When viewing reports: -Press "▲"UP or "▼"DOWN to select report #. -Press and hold "▲"UP or "▼"DOWN to change the displayed lines in VIEW. -Press SEND to print current viewed report. -Press and hold SEND to exit view.
	EXIT		Return to Sub Menu.
	EXIT		Return to main menu.
SCREEN	CONTRAST	00~20	Use to change screen contrast.
	AUX	LINE 1	-Select parameter displayed for each line.
		LINE 2	-Press "▲"UP to choose between:
		LINE 3	ΔT Temp differential
		LINE 4	CO Carbon Monoxide
	P Pressure	TIME (shows time)	
	X Excess Air	DATE (shows date)	
	Efn Efficiency	∇ Losses	
	NO NO	R CO/CO2 Ratio	
	COa CO Air Free	CO2 Carbon Dioxide	
	BAT Battery Level	O2 Oxygen	
	D Draft	TI Inlet Temp (T1)	
		TF Flue Temp (T2)	
EXIT		Return to Sub Menu.	
HEADER	HEADER1	Customize header information	
	HEADER2	Screen shows (*OUR COMPANY NAME & _ _ _ _) -Press UP or DOWN to scroll through letters and symbols to choose, press ENTER.	
EXIT		Return to Sub Menu.	
EXIT		Return to main menu.	
SERVICE	Used by technicians to calibrate combustion gas sensors.		

WHERE TO TEST

AIR CONDITIONING / HEAT PUMP

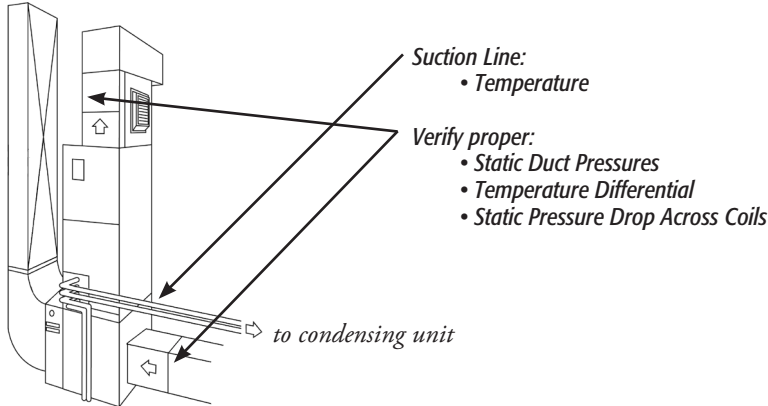

BOILER & WATER HEATERS & HIGH EFFICIENCY MODULATING HOT WATER SYSTEMS

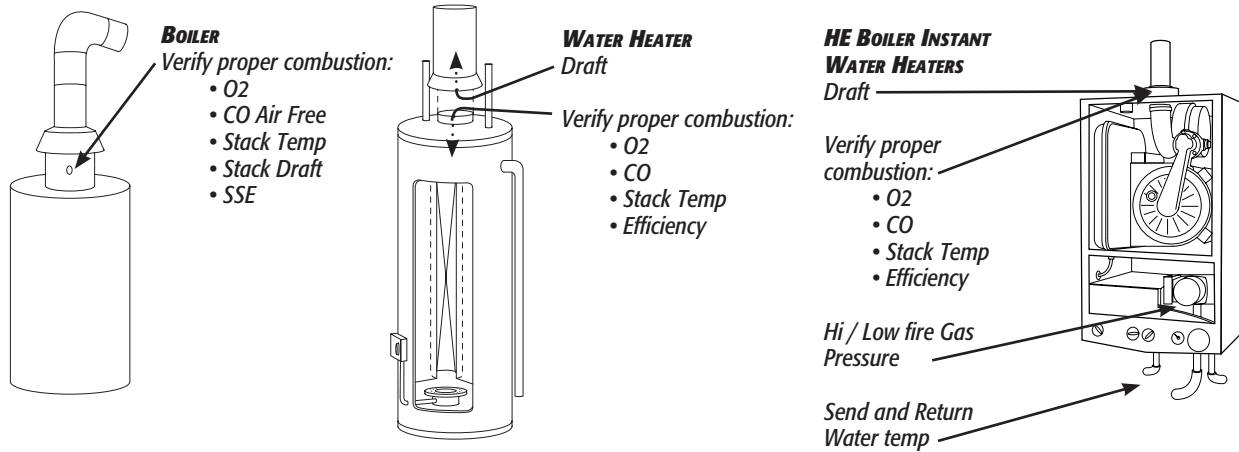

FURNACES: 80%

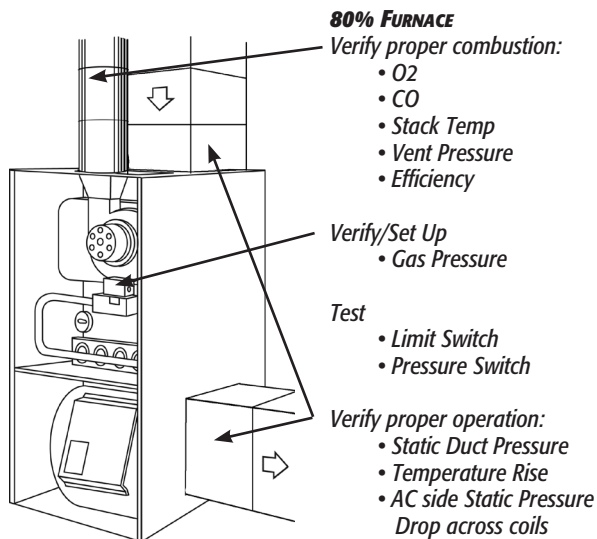

FURNACES: 90%

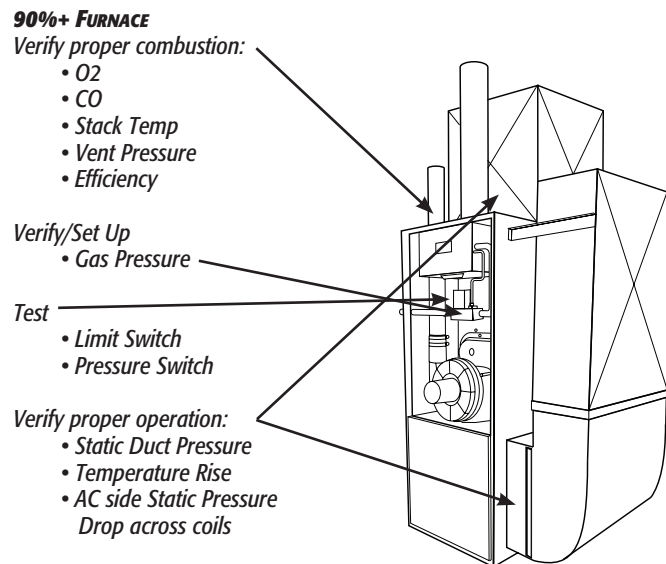

FURNACES (CONTINUED): ATMOSPHERIC, GAS & OIL

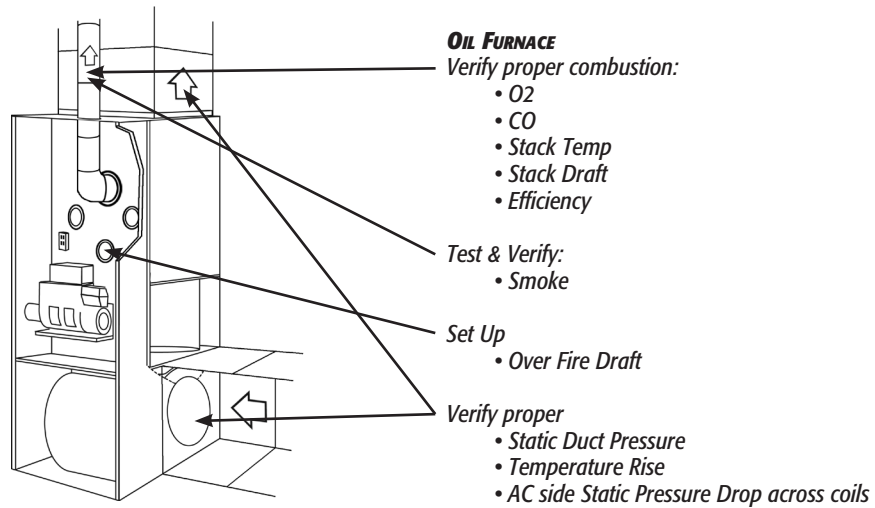
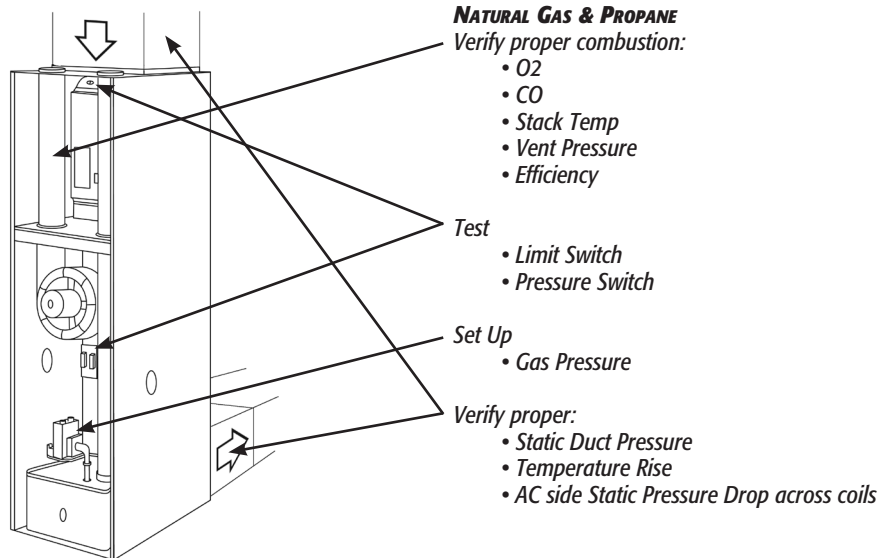
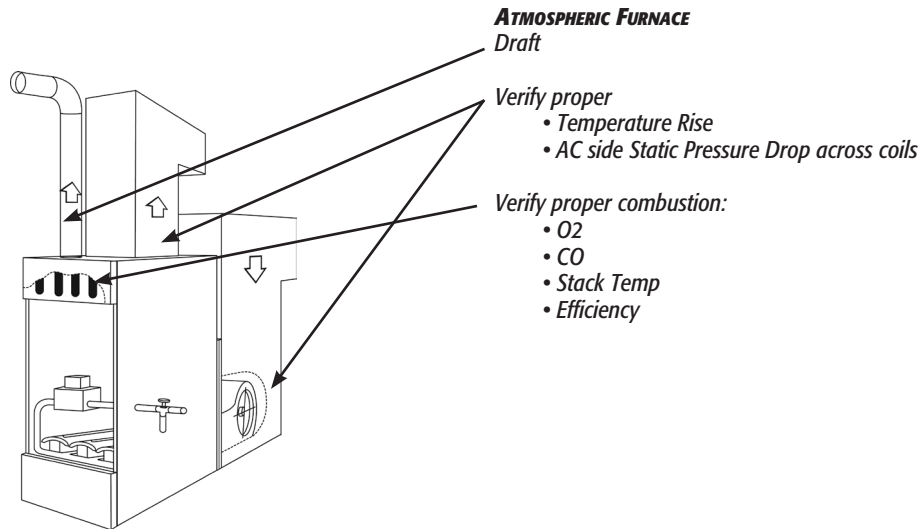

OTHER IMPORTANT FACTORS RELATING TO COMBUSTION

- The three T's of combustion
 - Time
 - Amount of time that the fuel and oxygen are together in the combustion chamber
 - Temperature
 - How high the temperature is determines the rate of oxidation, or speed of the combustion
 - Turbulence
 - How well the fuel and air are mixed
- These three factors are all interrelated, and will move your results along the combustion curves.

COMBUSTION MEASUREMENT TERMS

Other parameters measured include net temperature, draft and efficiency.

Net Temperature

Net temperature is the difference between the combustion air entering the combustion chamber and the flue gas temperature past the heat exchange. This is used to determine how efficient the system is extracting heat from the combustion process in addition to the performance of the combustion process. On sealed systems that have ducted inlet air for combustion air, the net temperature must compare this air stream temperature with the flue gases. If the appliance simply uses room air for the combustion air, our analyzers have an internal temperature sensor in the handset, so it will use this temperature when calculating net temperature.

The most accurate results for efficiency are obtained when measuring flue gases at the point where flue temperature (not flame temperature) is the highest.

Draft

Draft is the difference between the ambient pressure level and the pressure level in the flue. This is created either by the natural buoyancy of the hot gases created in combustion lifting, or by an inducer fan that assists the flow of flue gases up the stack. Most combustion equipment will specify the amount of draft that is required for proper operation.

Draft helps draw combustion air into the combustion chamber, and also helps in mixing the fuel and oxygen. Without proper draft, the combustion process can spill poisonous by-products into the space where the appliance is located. This can be a risk to those in the area, or create a danger to residents or employees working near the combustion equipment.

Efficiency

Efficiency is a measure of how well the fuel is burned to create heat, and how well the generated heat is captured for the intended use.

The information used to create this value are based on the fuels heating value, the heat lost up the flue and the gas components in the flue gas. The original method to determine efficiency included many manual methods and lookup charts. As an example you would measure the CO₂ level and the stack temperature and then reference a slide scale that would give you the relative efficiency number. UEi's electronic combustion analyzers perform the measurements on a continuous basis, and can calculate the efficiency as adjustments are being made. Combine this with a printout and you are able to provide a before and after comparison of the combustion equipment in relatively little time as part of normal servicing.

version has been ignored. This loss is subtracted from the efficiency.

CO AIR FREE

Certain standards (ANSI Z21.1) for Carbon Monoxide are stated in terms of air-free. Air-free refers to the concentration of CO in combustion gases undiluted with flue, or other gases containing little CO. This value is computed using an equation that takes into account the O₂ concentration of the flue gas.

- If 5% O₂ is measured (O_{2m}) in the flue then the CO gas value will be recalculated as if 0% were measured. The equation for air-free is as follows:
 - CO_{af} = CO PPM x [(20.9) / (20.9 - O_{2m})]
- In our example if a reading of 325 PPM were measured then the air-free value would be calculated as follows:
 - CO_{af} = 325 PPM x [(20.9) / (20.9 - 5)] CO_{af} = 325 PPM x [(20.9) / (15.9)] CO_{af} = 427

We may be given a limit on our gas range by the local authority, which stated that we must not emit more than 400-PPM Carbon Monoxide air-free. In the example we would be breaking the limit and corrective action should be taken to reduce the level of CO. Air-free values prevent false readings being submitted, e.g. allowing more air into the boiler will increase the oxygen level in the flue and dilute any toxic gas reading. Air-free referencing gives readings as if they were undiluted.

COMBUSTION EFFICIENCY CALCULATIONS

This identifies three sources of loss associated with fuel burning:

- Losses due to flue gasses:
 - Dry Flue gas loss, Moisture and hydrogen,
 - Sensible heat of water vapor, Unburned gas
- Losses due to refuse:
 - Combustible in ash, riddling and dust
- Other losses:
 - Radiation, convection, conduction other unmeasured losses

Net efficiency calculations assume that the energy contained in the water vapor (formed as a product of combustion and from wet fuel) is recovered and the wet loss term is zero. Gross efficiency calculations assume that the energy contained in the water vapor is not recovered. Since the fuel air mixture is never consistent there is the possibility of unburned/partially unburned fuel passing through the flue. This is represented by the unburned carbon loss. Losses due to combustible matter in ashes, riddling, dust and grit, radiation, convection and conduction are not included.

Efficiency Calculation:

- Known Data Fuel:
 - Q_{gr} = Gross Calorific Value (kJ/kg)
 - Q_{net} = Net Calorific Value (kJ/kg)
 - K₁ = Constant based on Gross or Net Calorific ••
- Known Data Value:
 - K_{1g} = (255 x %Carbon in fuel) / Q_{gr}
 - K_{1n} = (255 x %Carbon in fuel) / Q_{net}
 - K₂ = % max theoretical CO₂ (dry basis)
 - K₃ = % Wet Loss
 - H₂ = % Hydrogen
 - H₂O = % Water
- Measured Data:
 - T_f = Flue Temperature
 - T_i = Inlet Temperature
 - O_{2m} = % Oxygen in flue gas
 - O_{2r} = Oxygen reference %
- Calculated data:
 - T_{net} = Net Temperature
 - % CO₂ content in flue gas
 - % Dry Flue Gas losses
 - % Wet losses
 - % Unburned carbon loss
 - % Efficiency
- T_{net} = Flue Temperature - Inlet Temperature (or ambient)
- Dry flue gas loss %
 - = 20.9 x K₁ x (T_{net}) / K₂ x (20.9 - O_{2m})
- Wet loss %
 - = 9 x H₂ + H₂O / Q_{gr} x [2488 + 2.1T_f - 4.2 T_i]
- Simplified
 - = [(9 x H₂ + H₂O) / Q_{gr}] x 2425 x [1 + 0.001 T_{net}]
- Wet loss %
 - = K₃(1+0.001xT_{net})
- Where K₃
 - = [(9 x H₂ + H₂O) / Q_{gr}] x 2425
- Net Efficiency %
 - = 100 - dry flue gas losses
 - = 100 - 20.9 x K_{1n} x (T_{net}) / K₂ x (20.9 - O_{2m})
- Gross Efficiency %
 - = 100 - {dry flue gas losses + wet losses}
 - = 100 - {[20.9 x K_{1g} x (T_{net}) / K₂ x (20.9 - O_{2m})] + [K₃ x (1 + 0.001 x T_{net})]}
- Excess Air
 - = [20.9 / (20.9 - O_{2m}) - 1] x 100
- CO₂%
 - = [(20.9 - O_{2m}) x K₂ / 20.9]
- Unburned
 - = K₄ x CO / (CO + CO₂)
 - Note: CO scaled in % fuel Loss %
- Where K₄
 - = 70 for coke
 - = 65 for anthracite
 - = 63 for Bituminous coal
 - = 62 for coal tar fuel
 - = 48 for liquid petroleum fuel
 - = 32 for natural gas

The formula for K₄ is based on the gross calorific value Q_{gr}. To obtain the loss based on net calorific value multiply by Q_{gr}/Q_{net}. Since this loss is usually small this con-

GENERAL MAINTENANCE

GENERAL MAINTENANCE

- Calibrate your instrument annually to ensure it meets original performance specifications
- Keep your instrument dry. If it gets wet, wipe dry immediately. Liquids can degrade electronic circuits
- Whenever practical, keep the instrument away from dust and dirt that can cause premature wear
- Although your instrument is built to withstand the rigors of daily use, it can be damaged by severe impacts. Use reasonable caution when using and storing the meter

PERIODIC SERVICE



WARNING!

Repair and service of this instrument is to be performed by qualified personnel only. Improper repair or service could result in physical degradation of the instrument. This could alter the protection from personal injury this meter provides to the operator. Perform only those maintenance tasks that you are qualified to do.

ANNUAL RE-CALIBRATION

While the sensor has an expected life of more than two years in normal use it is recommended that the analyzer is re-calibrated at least annually, This is so that long-term drift on the sensor and electronics can be eliminated. Local regulations may require more frequent re-calibration and users should check with appropriate authorities to ensure they comply with relevant guidelines.

CLEANING



Periodically clean your instruments case using a damp cloth. DO NOT use abrasive, flammable liquids, cleaning solvents, or strong detergents as they may damage the finish, impair safety, or effect the reliability of the structural components.

EMPTYING & CLEANING THE IN-LINE WATER TRAP



The in-line water trap should be checked and emptied on a regular basis. Water vapor will condense in the probe line, which may cause the water trap to fill suddenly if the probe is moved. Care should be taken at all times.

Carefully remove the rubber plug from the bottom of the water-trap housing. Dispose of the condensate in a suitable drain, care must be taken as it could be acidic. If condensate spills onto the skin or clothing, clean off immediately using fresh water, seek medical advice if problems occur. Ensure plug is replaced before performing combustion tests. Note: O₂ reading will be high if the Water Trap Plug is not in place.

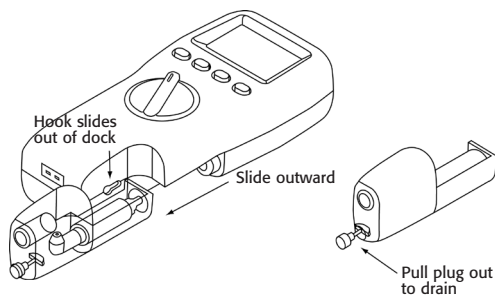

CHANGING THE PARTICLE FILTER

This is a very important part of the analyzer and should be changed regularly. It prevents dust and dirt particles from entering the pump and sensors that will cause damage. The filter **MUST** be changed when it appears discolored on the inner surface.

Remove water-trap assembly from the analyzer as shown above. Remove the filter and plastic holder from the housing. Discard the filter element but keep the holder to fit to the new filter. Clean the inside of the filter housing with a suitable soft cloth. Fit the holder onto the new filter element and then insert into the housing. Refit the housing onto the analyzer.

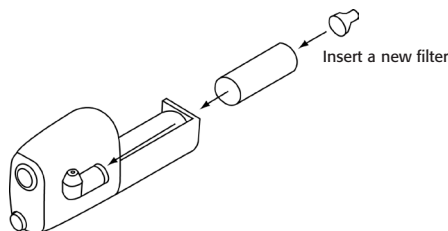

BATTERIES REPLACEMENT

This meter has been designed for use with both alkaline and rechargeable Nickel Metal Hydride (NiMH) batteries. No other types are recommended. The analyzer is supplied with 4 “AA” size alkaline batteries.

These should be installed into the instrument as shown in the diagram to the right and indicated on the back of the unit.



CAUTION!

Take great care when installing the batteries to observe correct polarity. Always check the meter for operation immediately after installing new batteries.

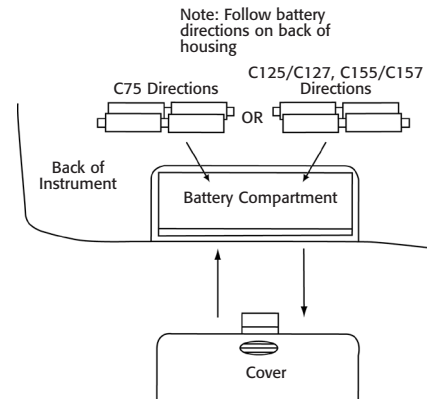

USING RE-CHARGEABLE BATTERIES

The battery charger must only be used when NiMH batteries are fitted. Alkaline batteries *are not* re-chargeable. Attempting to recharge alkaline batteries may result in damage to the product and may create a fire risk.

BATTERY CHARGING

Ensure that you use the correct charger. This unit uses a 9V DC regulated charger.

Ensure that the batteries are fitted in the correct manner, and then charge for at least 16 hours. Subsequent charges should be overnight. NiMH batteries may be charged at any time, even for short periods to conduct testing.



WARNING!

Under NO circumstance should you expose batteries to extreme heat or fire as they may explode and cause injury. Always dispose of old batteries promptly in a manner consistent with local disposal regulations.

ELECTROMAGNETIC COMPATIBILITY (EMC)

This product has been tested for compliance with the following generic standards: EN 50081-1, EN 50082-1 and is certified to be compliant.

The European Council Directive 89/336/EEC requires that electronic equipment does not generate electromagnetic disturbances that exceed defined levels and has an adequate level of immunity to enable it to be operated as intended.

Since there are many electrical products in use that pre-date this Directive and may emit electromagnetic radiation in excess of the standards defined in the Directive there may be occasions where it would be appropriate to check the analyzer prior to use. The following procedure should be adopted.

- Go through the normal start up sequence in the location where the equipment is to be used
- Switch on all localized electrical equipment that might be capable of causing interference
- Check that all readings are as expected (a level of disturbance in the readings is acceptable)
- If not, adjust the position of the instrument to minimize interference or switch off, if possible, the offending equipment for the duration of the test

At the time of writing this manual (July 2009) Uei is not aware of any field based situation where such interference has ever occurred and this advice is only given to satisfy the requirements of the Directive.

EAGLE SPECIFICATIONS

	C125	C127	C155	C157
Temperature Measurement				
Flue Temp Range	20~2400°F (-29~1315°C)			
Inlet Temperature (probe - T2)	20~2400°F (-29~1315°C)			
Inlet Temperature (ambient)	32~112°F (0~50°C)			
Net Temperature (_T)**	20~2400°F (-29~1315°C)			
Resolution	0.1°C/F			
Flue (T1, Inlet T2 & _T) Accuracy	±(0.3% rdg +3.6°F(2°C))			
Inlet Temperature Accuracy	±(0.3% rdg +1.8°F(1°C))			
Gas Measurement				
Oxygen	0~21%*	0~21%*	0~21%**	0~21%**
O2 resolution / accuracy	0.1% / ±0.2%	0.1% / ±0.2%	0.1% / ±0.3%	0.1% / ±0.3%
Carbon Monoxide (CO)	0~2000 ppm (4000 max 15 min)*			
CO resolution / accuracy	1ppm/ ±10ppm<100ppm ±5% rdg>100ppm			
Carbon Dioxide (CO2)	0~30%**	0~30%**	0~20%*	0~20%*
CO2 resolution / accuracy	0.1% / ±0.3%	0.1% / ±0.3%	0.1% / ±0.3%	0.1% / ±0.3%
Efficiency**	0~99.9%**	0~99.9%**	0~99.9%**	0~99.9%**
Efficiency resolution/accuracy	0.1% / ±3%	0.1% / ±3%	0.1% / ±3%	0.1% / ±3%
Excess Air**	0~250%**	0~250%**	0~250%**	0~250%**
Excess Air resolution/accuracy	0.1% / ±3%	0.1% / ±3%	0.1% / ±3%	0.1% / ±3%
CO/CO2 ratio**	0~0.999	0~0.999	0~0.999	0~0.999
CO/CO2 resolution/accuracy	0.001 / ± 5% rdg	0.001 / ± 5% rdg	0.001 / ± 5% rdg	0.001 / ± 5% rdg
Nitric Oxide (NO1)	-	-0~100 ppm	-	0~100 ppm
NO1 resolution/accuracy	-	±2 ppm<30ppm	-	±2 ppm<30ppm
	-	±5 ppm<100 ppm	-	±5ppm<100 ppm
Pressure (Differential)				
	Range		Accuracy	
	±0.08" wc (±0.2mBar)		±0.002" wc (±0.005mBar)	
	±0.4" wc (±1mBar)		±0.01" wc (±0.03mBar)	
	±32" wc (±80mBar)		±3% rdg	
Pressure Resolution				
	0.001" wc < 9.999" wg			
	0.01" wc >10.00" wg			
	0.001mBar<24.999mBar			
	0.01mBar > 25 mBar			

* Measured at STP (standard temperature and pressure)

** Calculated value

EAGLE & EAGLE X LIMITED WARRANTY

The Eagle Combustion Analyzers (C75, C125, C127) are warranted to be free from defects in materials and workmanship for a period of three years (two years on sensors) from the date of purchase. Eagle X (C155, C157) are each warranted for five years including sensors.

If within the warranty period your instrument should become inoperative from such defects, the unit will be repaired or replaced at UEi's option. This warranty covers normal use and does not cover damage which occurs in shipment or failure which results from alteration, tampering, accident, misuse, abuse, neglect or improper maintenance (calibration). Batteries and consequential damage resulting from failed batteries are not covered by warranty.

Any implied warranties, including but not limited to implied warranties of merchantability and fitness for a particular purpose, are limited to the express warranty. UEi shall not be liable for loss of use of the instrument or other incidental or consequential damages, expenses, or economic loss, or for any claim or claims for such damage, expenses or economic loss. A purchase receipt or other proof of original purchase date will be required before warranty repairs will be rendered. Instruments out of warranty will be repaired (when repairable) for a service charge. Contact UEi for specific warranty and service information. This warranty gives you specific legal rights. You may also have other rights which vary from state to state.

USA: 1.800.547.5740 • Fax: 503.643.6322
CANADA: 1-877-475-0648 • Fax: 604.278.8299
WWW.UEITEST.COM