









visidec®

Visidec Freestanding | Dual vertical VFS-DV

-  Suits 75x75 & 100x100mm (opt. 200x100mm support)*
-  Freestanding desk mount
-  Suits displays up to 12kgs (26.5lbs)
-  Holds two displays
-  Tool-less tilt & pan adjustment
-  Quick Release mounting head
-  Allows height adjustment
-  Adjustable screen orientation

The Visidec Freestanding Dual Vertical is a compact and durable desk stand that holds two monitors with individual height adjustability. The minimal footprint and integrated cable management help ensure a flexible and clutter-free work environment. Detachable display mounting heads support a wide variety of VESA compatible monitors with Quick Release for easy installation / maintenance and Quick Shift for easy adjustment. The heads feature a ball joint that allows tilt/ pan adjustment and landscape to portrait screen rotation. Integrated tension control ensures touch-screen support and the product ships with security screws to deter unauthorized screen removal.



Product key features:

- ✕ Holds two displays, each up to 450mm (17") high and 12kgs (26.5lbs) in weight
- ✕ Made from strong die cast aluminum with a steel base
- ✕ Ball joint mechanism allows +/-20° of tilt and pan adjustment as well as 360° screen rotation
- ✕ Integrated tension control for touch-screen compatibility
- ✕ Provides up to 736mm (29") of display height adjustment with tool-less Quick Shift operation
- ✕ Quick release mounting heads enable easy display installation and replacement with security screws to deter unauthorized removal.
- ✕ Small 422mm (16.25") wide by 305mm (12") deep footprint
- ✕ Provides a choice of internal and external cable management
- ✕ Comes with display mounting hardware



Quick Release mechanism for easy display attachment/removal with a security feature.



Quick Shift donut for easy vertical adjustment

Strong die cast aluminium construction with sturdy steel base

Height adjustable

Small foot print



Internal & external cable management

Ball joint with tension control allows tilt, pan and rotation



Atdec Global www.atdec.com.au
Atdec North America www.atdec.com

* Also supports 200x100mm via optional adaptor plate

Product information, single unit

Product Code	Load capacity	Material	Color
VFS-DV	12kg (26.5lbs) per display	Extruded anodized aluminium construction with a steel base and plastic trim.	Silver

Package information, single unit

Size	Ship weight	UPC code	Contents
81cm x 33cm x 10cm (32" x 13.25" x 3.75")	5.4kg (12.4lbs)	881493005112	Stand, mounting heads (x2), security screws (x2) & display mounting hardware

Package information, master pack

Size	Ship weight	UPC	Units per master pack
82cm x 34cm x 21cm (32.5" x 14" x 8.75")	12kg (26.6lbs)	881493005167	2

Technical drawings

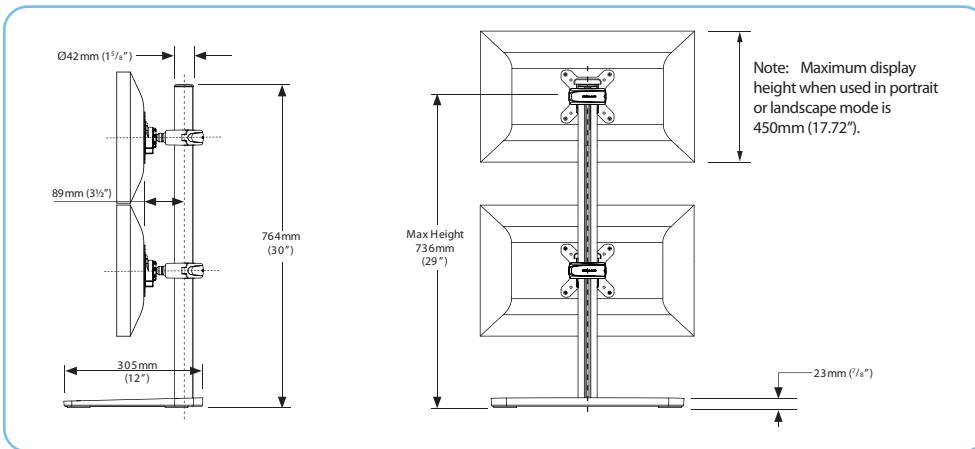

Base Dimensions

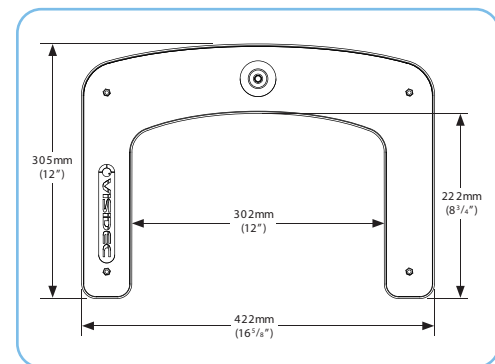

Optional Accessories

AC-AP-2010	200x100 Adaptor Plate
------------	-----------------------

Other models in this range

VFS-DH	Freestanding Dual Vertical
VFS-Q	Freestanding 2 X 2 Quad

Included VESA attachment

