

Color Video Camera

Technical Manual



EVI-D100/D100P

Table of Contents

Features	3
Connection	4
Locations of Controls	5
Basic Functions	7
Overview of Functions	7
Initial Values and Backup	11
Memory (Position preset) Function	12
Mode Condition	13
Command List	18
VISCA/RS-232C Commands	18
EVI-D100/P Commands	25
D30/D31 Mode	40
Overview	40
Switching the Mode	40
Accepting or Sending Back Commands	41
Translating Parameters	42
Specifications	46
Precautions	48

Features

- The CCD features 380,000 effective picture elements for the EVI-D100 and 440,000 for the EVI-D100P, which enables high-resolution shooting.
- In addition to high-speed pan/tilt action, improvement of the noise reduction mechanism lets you use the Color Video Camera for a variety of purposes.
- VISCA lets you operate your Color Video Camera from a computer.
- Up to six combinations of the camera's position and status can be memorized.
- A multi-function Remote Commander is provided.
- Thanks to the D30/D31 emulation function, you can control your Color Video Camera using the same commands as those used for the EVI-D30/D31.

Connection

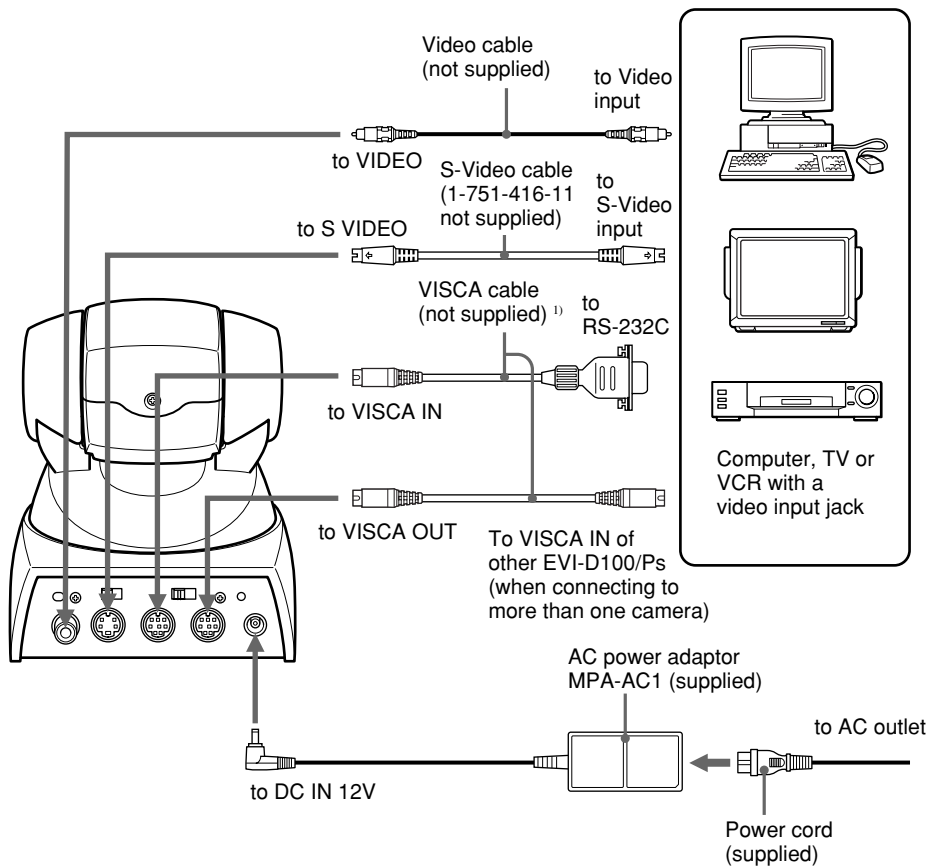

- 1) When the camera is connected to a computer with a VISCA cable (RS-232C, cross type), you can operate the camera with the computer. To obtain a cable, consult the dealer where you bought your camera.

Locations of Controls

Main Unit

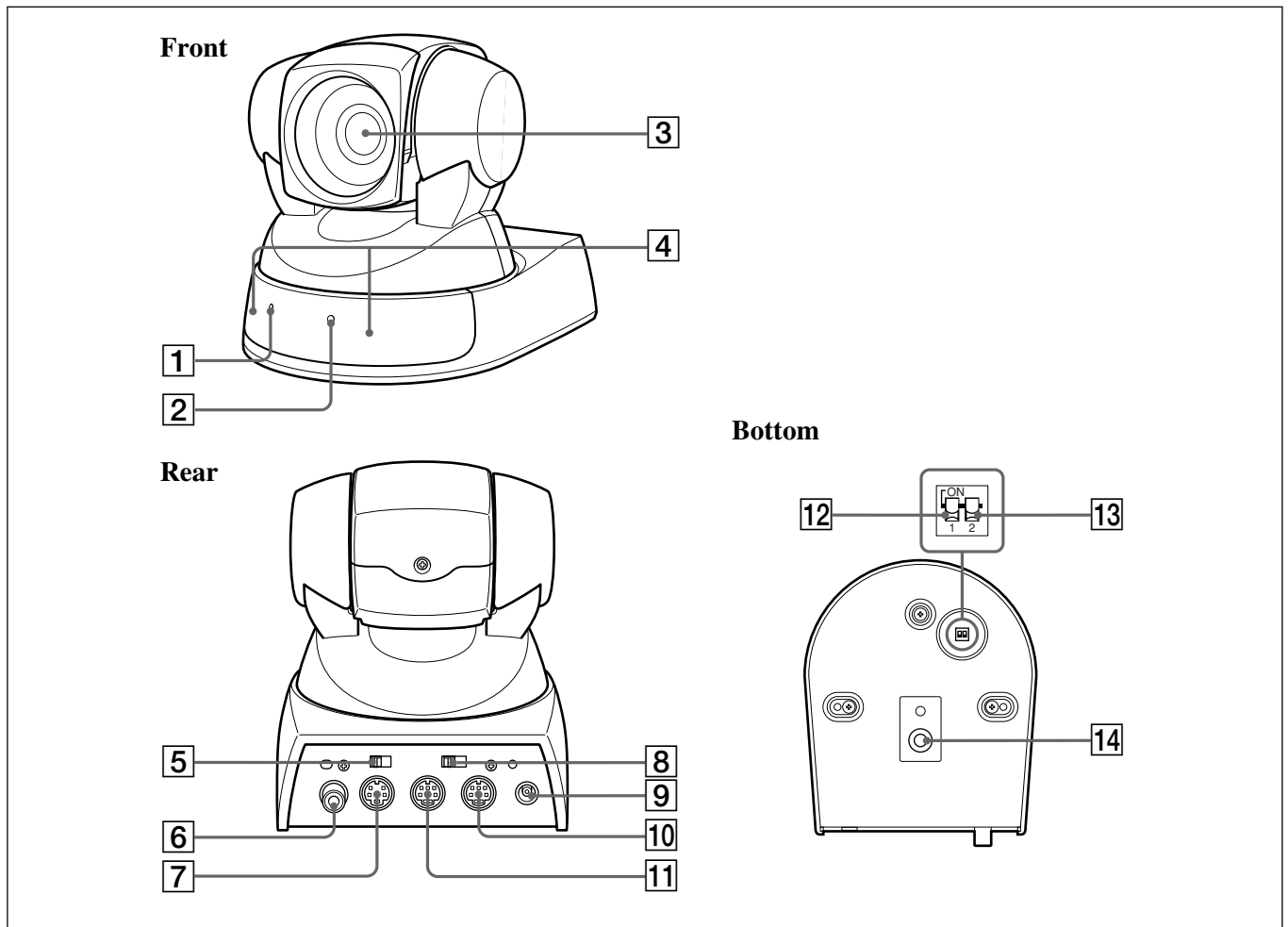

- 1 POWER lamp
- 2 STANDBY lamp
- 3 Lens
- 4 Sensor for the remote commander
- 5 BACKUP switch
- 6 VIDEO jack
- 7 S VIDEO jack
- 8 IR SELECT switch
- 9 DC IN 12 V jack

- 10 VISCA OUT jack
- 11 VISCA IN jack
- 12 IR SELECT switch
Set this switch to ON to allow the camera output signals transmitted from the Remote Commander to the Color Video Camera via the VISCA OUT jack to be output. When you don't intend to do so, set it to OFF.

- 13 D30/D31 mode switch
Set this switch to ON to enable you to operate the Color Video Camera using the VISCA commands for the EVI-D30/D31. When you don't intend to do so, set it to OFF.

Note

You cannot use some of the commands of the EVI-D30/D31 even if you set this switch to ON.

- 14 Tripod hole

Remote Commander

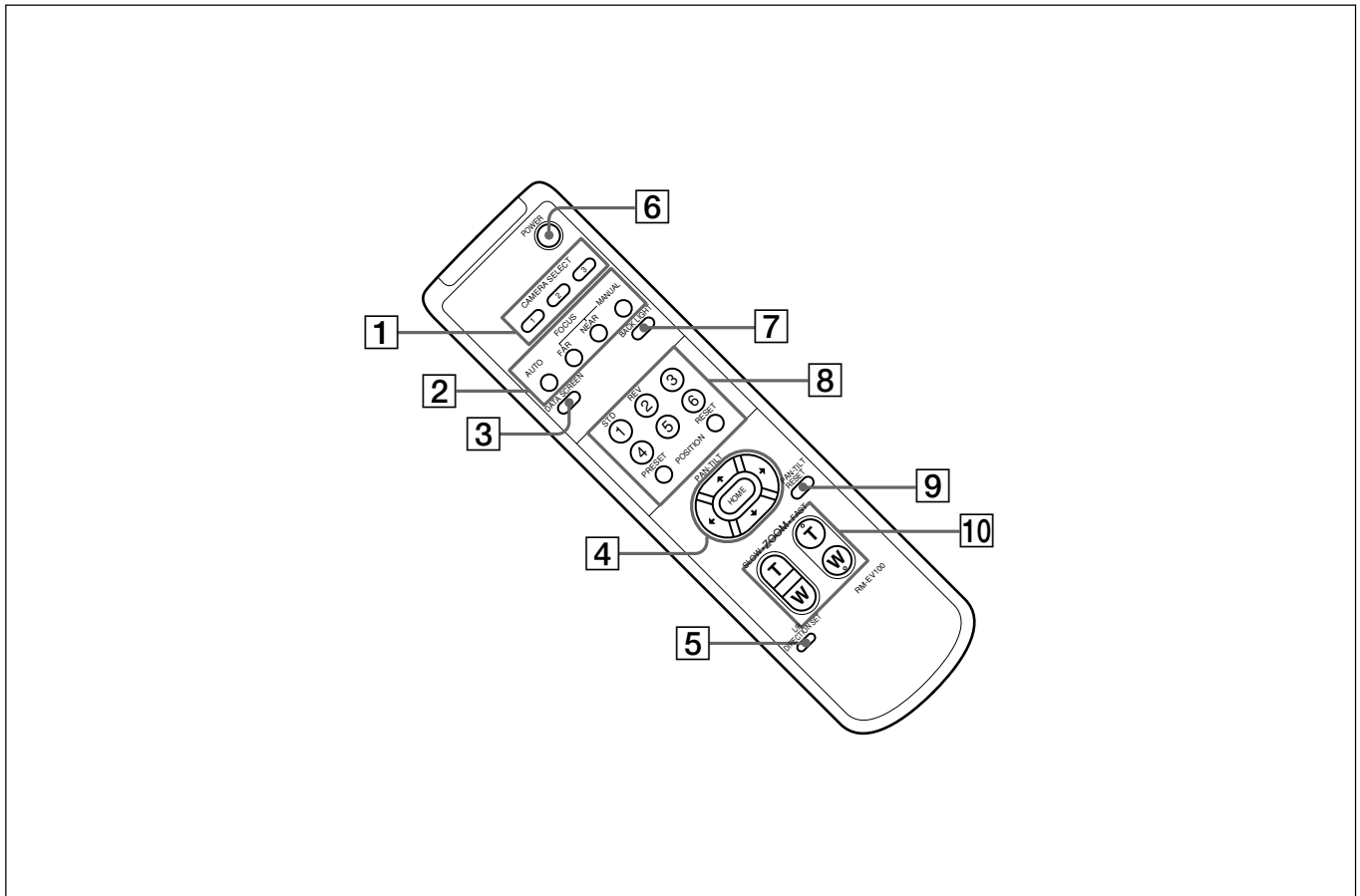

1 CAMERA SELECT buttons

2 FOCUS buttons

AUTO button
 FAR button
 NEAR button
 MANUAL button

3 DATA SCREEN button

4 PAN-TILT button

Arrow buttons
 HOME button

5 L/R DIRECTION SET button

6 POWER switch

7 BACK LIGHT button

8 POSITION buttons

Numeric buttons (Button 1 also works as the STD button. Button 2 also works as the REV button.)
 PRESET button
 RESET button

9 PAN-TILT RESET button

10 ZOOM buttons

SLOW T button
 SLOW W button
 FAST T button
 FAST W button

Basic Functions

Overview of Functions

Zoom

The EVI-D100/P uses an 10× optical zoom lens. And its digital zoom function allows you to zoom up to 40×.

- **Optical 10×, f = 3.1 to 31 mm (F 1.8 to F 2.9)**

The horizontal angle of view is approximately 65 degrees (wide end) to 6.6 degrees (tele end).

Digital zoom increases the picture element size and reduces the resolution.

Extended control of zoom:

- Direct zoom position
- Zoom speed selection (8 speeds)
- Digital zoom can be switched ON/OFF

Focus

The minimum focus distance is 100 mm at the optical wide end and 600 mm at the optical tele end, and is independent of the digital zoom.

The AutoFocus (AF) function automatically adjusts the focus position to maximise the high frequency content of the picture in a center measurement area, taking into consideration the high luminance and strong contrast components.

Note

AVOID 24-hour continuous use of the autofocus. This may cause lens malfunction.

All of these settings are performed via RS-232C control. If the RS-232C is not used, white balance, iris and gain adjustments will be carried out automatically, and the shutter speed will be fixed at 1/60 seconds for the EVI-D100 and 1/50 seconds for the EVI-D100P.

Extended control of focus:

- Direct focus position
- Minimum focus distance limitation
- Manual focus speed selection (8 speeds)
- AutoFocus can be set to High or Low mode
- One Push AF can be achieved in manual focus mode

- **HIGH AF**

High reaction speed of the AF. Use this mode when shooting fast moving objects. Recommended as the optimum mode for normal NON-CONTINUOUS use.

- **LOW AF**

Better focus stability. In low luminance conditions, the AF discontinues operation even when brightness changes, enabling stable images.

White Balance

- **Auto**

Auto Tracing White Balance with limitations on R and B gain (3000 to 7500 K), to avoid fixing single color scenes as 'white'

- **ATW**

Auto Tracing White balance (2000 to 10000 K)

- **Indoor**

3200 K

- **Outdoor**

5800 K

- **One Push WB**

One Push White Balance ¹⁾

- **Manual WB**

Manual control of R and B gain, 256 steps each

1) The One Push White Balance mode is a fixed white balance mode that may be automatically readjusted only at the request of the user (One Push Trigger), assuming that a white subject, in correct lighting conditions, and occupying more than 1/2 of the image, is submitted to the camera.

Selecting the One Push White Balance mode recalls the white balance data computed at the last One Push Trigger, if the BACKUP switch is set to ON and the camera has been connected to an AC outlet. The data is erased when the camera is disconnected from the AC outlet. Adjust the One Push White Balance again on the next time it is used.

Automatic Exposure Mode

This mode is set to "Full Auto" at shipment. Altogether 9 modes are available, including this one.

- **Full Auto**

Auto Iris and Gain, Fixed Shutter (EVI-D100: 1/60 sec., EVI-D100P: 1/50 sec.)

- **Shutter Priority**¹⁾

Variable Shutter Speed, Auto Iris and Gain (1/4 (EVI-D100) or 1/3 (EVI-D100P) to 1/10,000 sec., 20 steps, std. shutter: 16 steps, slow shutter: 4 steps)

- **Iris Priority**

Variable Iris (F1.8 to Close, 18 steps), Auto Gain and Shutter speed

- **Gain Priority**

Variable Gain (-3 dB to 18 dB, 8 steps), Auto Iris and Fixed Shutter

- **Manual**

Variable Shutter, Iris and Gain

- **Bright**

Variable Iris and Gain (Close to F2.0, 17 steps at 0 dB: F1.8, 7 steps from 0 to 18 dB)

- **Iris Auto**

Variable Gain and Shutter speed

- **Shutter Auto**

Variable Iris and Gain

- **Gain Auto**

Variable Iris and Shutter speed

1) Flicker can be eliminated by setting shutter to

→ 1/100s for NTSC models used in countries with a 50 Hz power supply frequency

→ 1/120s for PAL models used in countries with a 60 Hz power supply frequency

AE – Shutter priority

The shutter speed can be set freely by the user to a total of 20 steps – 16 high speeds and 4 low speeds. When the slow shutter is set, the speed can be 1/30s (1/25s), 1/15s (1/12s), 1/8s (1/6s), 1/4s (1/3s) for NTSC (PAL) models. The picture output is read at a normal rate from the memory. The memory is updated at a low rate from the CCD. AF capability is low.

In high speed mode, the shutter speed can be set up to 1/10,000s.

The iris and gain are set automatically, according to the brightness of the subject.

Data	NTSC	PAL
13	10000	10000
12	6000	6000
11	4000	3500
10	3000	2500
0F	2000	1750
0E	1500	1250
0D	1000	1000
0C	725	600
0B	500	425
0A	350	300
09	250	215
08	180	150
07	125	120
06	100	100
05	90	75
04	60	50
03	30	25
02	15	12
01	8	6
00	4	3

AE – Iris priority

The iris can be set freely by the user to 18 steps between F1.8 and Close.

The gain and shutter speed are set automatically, according to the brightness of the subject.

Data	Setting value	Data	Setting value
11	F1.8	08	F8
10	F2	07	F9.6
0F	F2.4	06	F11
0E	F2.8	05	F14
0D	F3.4	04	F16
0C	F4	03	F19
0B	F4.8	02	F22
0A	F5.6	01	F28
09	F6.8	00	CLOSE

AE – Gain priority

The gain can be set freely by the user to 8 steps between -3 dB and +18 dB.

The shutter speed is fixed and the iris is set automatically, according to the brightness of the subject.

Data	Setting value
07	18 dB
06	15 dB
05	12 dB
04	9 dB
03	6 dB
02	3 dB
01	0 dB
00	-3 dB

AE – Manual

The shutter speed (20 steps), iris (18 steps) and gain (8 steps) can be set freely by the user.

AE – Bright

The bright control function adjusts both gain and iris using an internal algorithm, according to a brightness level freely set by the user. Exposure is controlled by gain when dark, and by iris when bright.

As both gain and iris are fixed, this mode is used when exposing at a fixed camera sensitivity. Only when the AE mode is set to “Full Auto” or “Shutter Priority,” can you switch the mode to “Bright.”

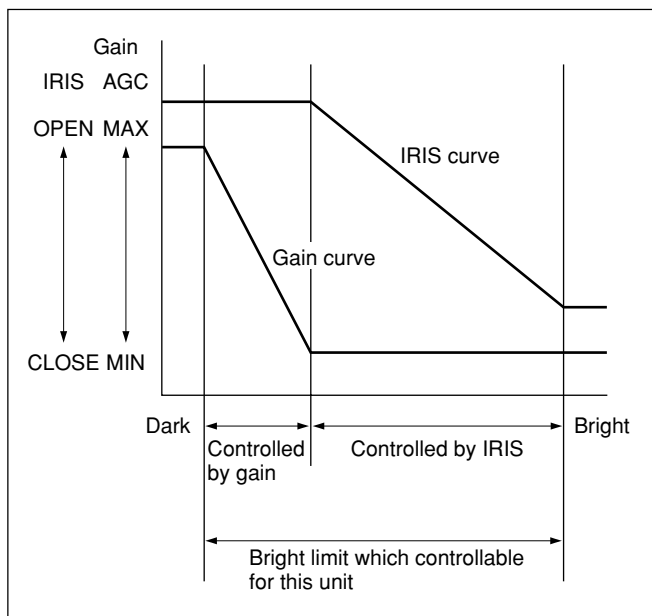

Data	Iris	Gain	Data	Iris	Gain
17	F1.8	18 dB	0B	F4.8	0 dB
16	F1.8	15 dB	0A	F5.6	0 dB
15	F1.8	12 dB	09	F6.8	0 dB
14	F1.8	9 dB	08	F8	0 dB
13	F1.8	6 dB	07	F9.6	0 dB
12	F1.8	3 dB	06	F11	0 dB
11	F1.8	0 dB	05	F14	0 dB
10	F2	0 dB	04	F16	0 dB
0F	F2.4	0 dB	03	F19	0 dB
0E	F2.8	0 dB	02	F22	0 dB
0D	F3.4	0 dB	01	F28	0 dB
0C	F4	0 dB	00	CLOSE	0 dB

When switching from the Shutter Priority mode to the Bright mode, the shutter speed set in the Shutter Priority mode is maintained. After that, you can set the shutter speed as you wish, independent of the Bright mode control.

AE – Shutter Auto

The iris and gain are set freely by the user, and the shutter speed changes automatically according to the brightness of the subject. Slow shutter is disabled.

AE – Iris Auto

The gain and shutter speed are set freely by the user, and the iris changes automatically according to the brightness of the subject.

AE – Gain Auto

The iris and shutter speed are set freely by the user, and the gain changes automatically according to the brightness of the subject.

Exposure Compensation

Exposure compensation is a function which offsets the internal reference brightness level used in the AE mode, by steps of 1.5 dB.

Data	Step	Setting value
0E	7	10.5 dB
0D	6	9 dB
0C	5	7.5 dB
0B	4	6 dB
0A	3	4.5 dB
09	2	3 dB
08	1	1.5 dB
07	0	0 dB
06	-1	-1.5 dB
05	-2	-3 dB
04	-3	-4.5 dB
03	-4	-6 dB
02	-5	-7.5 dB
01	-6	-9 dB
00	-7	-10.5 dB

Aperture Control

Aperture control is a function which adjusts the enhancement of the edges of objects in the picture. There are 16 levels of adjustment, starting from “no enhancement.” When shooting text, this control may help by making them sharper.

Back Light Compensation

When the background of the subject is too bright, or when the subject is too dark due to shooting in the AE mode, back light compensation will make the subject appear clearer.

Picture Effect

It consists of the following functions.

- **Pastel:** Pastel Image
- **Neg. Art:** Negative/Positive Reversal
- **Sepia:** Sepia Image
- **Black White:** Monochrome Image
- **Solarize:** Enhanced Contrast
- **Mosaic:** Mosaic Image
- **Slim:** Vertical Stretch
- **Stretch:** Horizontal Stretch

Digital Effect

Digital Effect consists of the following functions. They are all executed via the field memory.

- **Still:** Moving Image on Still Image
- **Flash:** Continuous Still Image
- **Lumi.:** Moving Images on Binaried Still Image
- **Trail:** Afterimage Lag of Moving Subject

Others

Mirror image

The video output from the camera can be reversed left and right using this function.

Freeze

This function captures an image in the field memory of the camera so that this image can be output continuously.

Memory (Position preset)

Using the position preset function, 6 sets of camera shooting conditions can be stored and recalled. This function allows the desired zoom position, focus (auto, manual positions), white balance, shutter speed, bright control, iris, gain, exposure compensation, back light compensation, and aperture to be set instantaneously without having to adjust them individually each time. It also memorizes the settings for digital zoom on/off, slow shutter auto/manual.

Backup

Backs up the contents memorized by the memory (position preset) function and the camera functions when the power is turned OFF. The BACKUP switch can be switched as follows.

- **ON side**
Backs up for about one year when the internal battery is fully recharged.
(Full recharge takes about 48 hours in power ON state.)
- **OFF side**
No back up. The switch is set to OFF at shipment.
(All settings return to initial values when the power is turned on the next time.)

Slow shutter – Auto/Manual

When set to “Auto,” ensures that the slow shutter is set automatically when the brightness drops. Effective only when the AE mode is set to “Full Auto.” Set to “Slow Shutter Manual” at shipment.

Initial Values and Backup

Initial values of functions of the EVI-D100/P are indicated in the “Initial values” column.

An ○ in the “Backed up/Not backed up” column indicates that the setting is memorized in the camera.

An × indicates that it is not.

Category	Mode/Position	Initial values	Backed up/Not backed up (○: Backed up, ×: Not backed up)
Pan/Tilt	Pan/Tilt Position	Home position	○
	Pan/Tilt Limit Position	movable-range maximum	○
Zoom	Zoom Position	Wide end	○
	Digital Zoom On/Off	On	○
Focus	Focus Mode Auto/Manual	Auto	○
	AF Sens High/Low	High	○
	Focus Position	—	○
	Near Limit	Near end	○
WB	WB Mode	Auto	○
	R/B Gain	—	○
AE	AE Mode	Full Auto	○
	Slow Shutter Auto/Manual	Manual	○
	Shutter Position	—	○
	Iris Position	—	○
	Gain Position	—	○
	Bright Position	—	○
	ExpComp On/Off	Off	○
	ExpComp Position	±0	○
Back Light On/Off	Off	○	
Aperture	Aperture Gain	5	○
Effect	Wide Mode	Off	×
	LR Reverse On/Off	Off	×
	Freeze On/Off	Off	×
	Picture Effect Mode	Off	×
	Digital Effect Mode	Off	×
	Digital Effect Level	0	×
OSD	Datascreen On/Off	Off	×
IR	IR_Receive On/Off	On	○ ¹⁾
	IR_ReceiveReturn On/Off	Off	○ ¹⁾
AutoPowerOff	Auto Power Off Timer	0	○ ¹⁾
Memory	Position Preset Data	—	○
VISCA	VISCA Address	1	× ^{1),2)}

1) The data items are backed up regardless of the BACKUP switch setting when you turn the power off using a VISCA command or the Remote Commander (standby mode).

2) When the camera is in the D30/D31 mode, the VISCA address is backed up.

Memory (Position Preset) Function

You can save the camera settings and pan/tilt position using the supplied Remote Commander or the VISCA commands. Six channels are available.

Data items saved in memory in the Color Video Camera

Category	Mode/Position
Pan/Tilt	Pan/Tilt Position
Zoom	Zoom Position
	Digital Zoom On/Off
Focus	Focus Mode Auto/Manual
	Focus Position
WB	WB Mode
	R/B Gain
AE	AE Mode
	Slow Shutter Auto/Manual
	Shutter Position
	Iris Position
	Gain Position
	Bright Position
	ExpComp On/Off
	ExpComp Position
	Back Light On/Off
Aperture	Aperture Gain

Mode Condition

Mode Condition 1

Command	Mode	Power OFF	Initializing ¹⁾	IFC ²⁾	Other status
Address Set		○	○	○	○
IF_Clear		○	○	○	○
Power On		○	×	×	○
Power Off		○	×	×	○
AutoPowerOff setting		×	×	×	○
IR_Receive On/Off		○	○	×	○
IR_ReceiveReturn On/Off		○	○	×	○
CAM_DeviceTypeInq/VersionInq		○	○	○	○
CAM_PowerInq/Pantilt Mode Inq		○	○	○	○
BlockInquiry		○	○	○	○
InquiryCommand (etc.)		×	○	○	○

1) Initializing: The period from the instant you connect the camera to an AC outlet to the instant the camera outputs a video signal. Or the period between sending the Cam_PowerOn command and receiving the Completion message.

2) IFC: The period between sending the IF_Clear command and receiving the Reply Packet.

Mode Condition 2 (Zoom)

Command	Mode	Power OFF	Initializing	IFC	Freeze On	Tele/Wide adjustment		Zoom Direct execution	Memory Recall execution
						VISCA	RC ¹⁾		
Zoom Tele/Wide/Stop	VISCA	×	×	×	×	○	○	×	×
	RC	×	×	×	×	×	○	×	×
Zoom Direct		×	×	×	○	○	○	○	×
D-Zoom On/Off		×	×	×	○	○	○	○	×

1) RC: Remote Commander

Mode Condition 3 (Focus)

Command	Mode	Power OFF	Initializing	IFC	Freeze On	AF ON	Far/Near adjustment		Focus Direct execution	Memory Recall execution
							VISCA	RC		
Focus Far/Near/Stop	VISCA	X	X	X	X	X	○	○	X	X
	RC	X	X	X	X	X	X	○	X	X
Focus Direct		X	X	X	○	X	○	○	○	X
Focus Mode Auto/Manual		X	X	X	X	○	○	○	○	X
One Push AF Trigger		X	X	X	X	X	X	X	X	X
Focus Infinity		X	X	X	X	○	○	○	X	X
AF Sens High/Low		X	X	X	○	○	○	○	○	○
Focus Near Limit		X	X	X	○	○	○	○	○	X

Mode Condition 4 (White Balance)

Command	Mode	Power OFF	Initializing	IFC	Freeze On	Memory Recall execution	White Balance mode					
							Auto	Indoor	Outdoor	One Push	ATW	Manual
White Balance mode setting Auto/Indoor/Outdoor/ OnePushWB/ATW/Manual		X	X	X	X	X	○	○	○	○	○	○
		X	X	X	X	X	X	X	X	X	X	X
One Push WB Trigger		X	X	X	X	X	X	X	X	X	X	X
R/B Gain Reset/Up/Down/Direct		X	X	X	X	X	X	X	X	X	X	○

Mode Condition 5 (Auto Exposure)

Mode Command	Power OFF	Initializing	IFC	Freeze On	Memory Recall execution	Auto Exposure mode									
						Full Auto	Manual	Shutter Pri	Iris Pri	Gain Pri	Shutter Auto	Iris Auto	Gain Auto	Bright	
AE mode setting Full Auto/Manual/ Shutter Pri/Iris Pri/ Gain Pri/ Shutter Auto/ Iris Auto/Gain Auto	X	X	X	X	X	O	O	O	O	O	O	O	O	O	O
AE mode setting Bright	X	X	X	X	X	O	X	O	X	X	X	X	X	X	X
Slow Shutter Auto/Manual	X	X	X	X	X	O	O	O	O	O	O	O	O	O	O
Shutter Reset/Up/Down/ Direct ²⁾	X	X	X	X	X	X	O	O	X	X	X	O	O	O	X ¹⁾
Iris Reset/Up/Down/ Direct	X	X	X	X	X	X	O	O	O	X	X	X	O	O	X
Gain Reset/Up/Down/ Direct	X	X	X	X	X	X	O	O	X	O	O	X	X	X	X
Bright Reset/Up/Down/ Direct	X	X	X	X	X	X	O	O	X	X	X	X	X	X	O
ExpComp On/Off	X	X	X	X	X	O	O	O	O	O	O	O	O	O	O
ExpComp Reset/Up/Down/ Direct ³⁾	X	X	X	X	X	O	O	O	O	O	O	O	O	O	O
Back Light On/Off	X	X	X	X	X	O	X	X	X	X	X	X	X	X	X

1): O only when the AE mode turns "Shutter Pri" into "Bright"

2): While activating a Digital Effect function, you cannot set functions related to Slow Shutter.

3): X when the Exposure Compensation function is set to off

Mode Condition 6 (Effect Setting, etc.)

Command	Mode	Power OFF	Initializing	IFC	Freeze On	Memory Recall execution	Slow Shutter activated	Digital Effect activated
Aperture Reset/Up/Down/Direct		X	X	X	X	X	O	O
Wide Off/Cinema/16:9Full		X	X	X	X	O	O	O
LR_Reverse On/Off		X	X	X	X	O	O	O
Freeze On/Off		X	X	X	O	X	O	X
Picture Effect Off/Pastel/NegArt/Sepia/B&W/ Solarize/Mosaic/Slim/Stretch		X	X	X	X	O	O	O
Digital Effect Off/Still/Flash/Lumi./Trail		X	X	X	X	O	X	O
Digital Effect Level		X	X	X	X	O	O	O
Datascreen On/Off		X	X	X	O	O	O	O

Mode Condition 7 (Pan/Tilt, Memory Function)

Command	Mode		Power OFF	Initializing	IFC	Freeze On	Zoom	Focus (manual) adjustment	Pan/Tilt movement				Memory Recall execution		Position detection error
	Transmit device								Up/Down/Left/Right/UpLeft/UpRight/DownLeft/DownRight	Absolute Position	Relative Position	Home	Reset	VISCA	
Pan-tiltDrive Up/Down/Left/Right/UpLeft/UpRight/DownLeft/DownRight	VISCA		X	X	X	O	Common	Common	VISCA	VISCA	RC	X	X	X	O
	RC		X	X	X	O			VISCA	VISCA	RC	X	X	X	O
Pan-tiltDrive Stop	VISCA		X	X	X	O			VISCA	VISCA	RC	X	X	X	O
Pan-tiltDrive AbsolutePosition	VISCA		X	X	X	O			VISCA	VISCA	RC	X	X	X	X
Pan-tiltDrive RelativePosition	VISCA		X	X	X	O			VISCA	VISCA	RC	X	X	X	O
Pan-tiltDrive Home	VISCA		X	X	X	O			VISCA	VISCA	RC	X	X	X	X
	RC		X	X	X	O			VISCA	VISCA	RC	X	X	X	X
Pan-tiltDrive Reset	VISCA		X	X	X	O			VISCA	VISCA	RC	X	X	X	O
	RC		X	X	X	O			VISCA	VISCA	RC	X	X	X	O
Pan-tiltDrive LimitSet	VISCA		X	X	X	O			VISCA	VISCA	RC	X	X	X	X
Pan-tiltDrive LimitClear	VISCA		X	X	X	O			VISCA	VISCA	RC	X	X	X	X
Memory Set	Common		X	X	X	X		X	VISCA	VISCA	RC	X	X	X	X
Memory Reset	Common		X	X	X	X		X	VISCA	VISCA	RC	X	X	X	X
Memory Recall	VISCA		X	X	X	X ¹⁾		X ²⁾	VISCA	VISCA	RC	X	X	O	X
	RC		X	X	X	X ¹⁾		X ²⁾	VISCA	VISCA	RC	X	X	O	X

1): O while the camera operates in the Tele/Wide zoom mode

2): O while the camera operates in the Far/Near focus mode

Command List

VISCA¹⁾/RS-232C Commands

Use of RS-232C control software which has been developed based upon this command list may cause malfunction or damage to hardware and software. Sony Corporation is not liable for any such damage.

Overview of VISCA

In VISCA, the side outputting commands, for example, a computer, is called the controller, while the side receiving the commands, such as an EVI-D100/P, is called the peripheral device. The EVI-D100/P serves as a peripheral device in VISCA. In VISCA, up to seven peripheral devices like the EVI-D100/P can be connected to one controller using communication conforming to the RS-232C standard. The parameters of RS-232C are as follows.

- Communication speed: 9600 bps
- Data bits : 8
- Start bit : 1
- Stop bit : 1
- Non parity
- MSB first

Flow control using XON/XOFF and RTS/CTS, etc., is not supported.

Peripheral devices are connected in a daisy chain. As shown in Fig. 1, the actual internal connection is a one-direction ring, so that messages return to the controller via the peripheral devices. The devices on the network are assigned addresses.

The address of the controller is fixed at 0. The addresses of the peripheral devices are 1, 2, 3 ... in order, starting from the one nearest the controller. The address of the peripheral device is set by sending address commands during the initialization of the network.

The VISCA devices each have a VISCA IN and VISCA OUT connector.

Set the DTR input (the S output of the controller) of VISCA IN to H when controlling VISCA equipment from the controller.

Fig. 1 VISCA network configuration

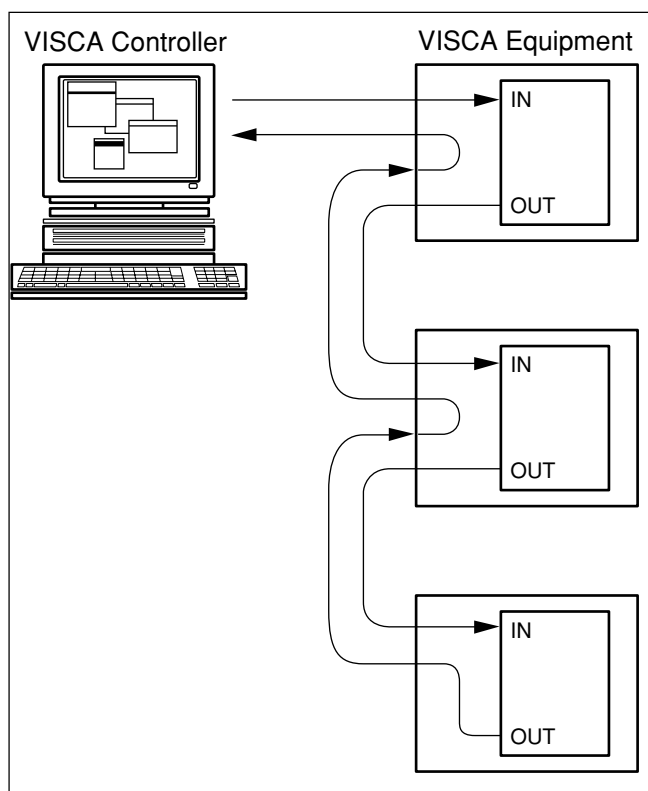

1) VISCA is a protocol which controls consumer camcorders developed by Sony. "VISCA" is a trademark of Sony Corporation.

VISCA Communication Specifications

VISCA packet structure

The basic unit of VISCA communication is called a packet (Fig. 2). The first byte of the packet is called the header and comprises the sender's and receiver's addresses. For example, the header of the packet sent to the EVI-D100/P assigned address 1 from the controller (address 0) is hexadecimal 81H. The packet

sent to the EVI-D100/P assigned address 2 is 82H. In the command list, as the header is 8X, input the address of the EVI-D100/P at X. The header of the reply packet from the EVI-D100/P assigned address 1 is 90H. The packet from the EVI-D100/P assigned address 2 is A0H.

Some of the commands for setting EVI-D100/P units can be sent to all devices at one time (broadcast). In the case of broadcast, the header should be hexadecimal 88H.

When the terminator is FFH, it signifies the end of the packet.

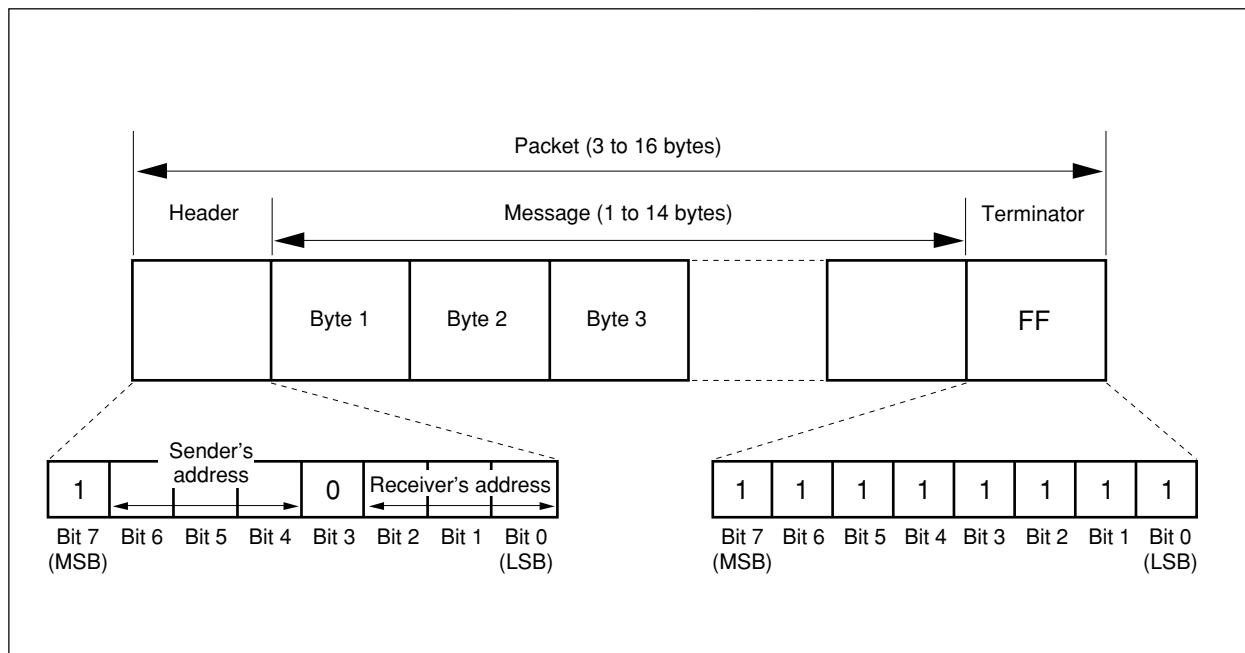

Fig.2 Packet structure

Command and inquiry

● Command

Sends operational commands to the EVI-D100/P.

● Inquiry

Used for inquiring about the current state of the EVI-D100/P.

	Command Packet	Note
Inquiry	8X QQ RR ... FF	QQ ¹⁾ = Command/Inquiry, RR ²⁾ = category code

¹⁾ QQ = 01 (Command), 09 (Inquiry)

²⁾ RR = 00 (Interface), 04 (camera 1), 06 (Pan/Tilter)

X = 1 to 7: EVI-D100/P address

Responses for commands and inquiries

● ACK message

Returned by the EVI-D100/P when it receives a command. No ACK message is returned for inquiries.

● Completion message

Returned by the EVI-D100/P when execution of commands or inquiries is completed. In the case of inquiry commands, it will contain reply data for the inquiry after the 3rd byte of the packet. If the ACK message is omitted, the socket number will contain a 0.

	Reply Packet	Note
Ack	X0 4Y FF	Y = socket number
Completion (commands)	X0 5Y FF	Y = socket number
Completion (Inquiries)	X0 5Y ... FF	Y = socket number

X = 9 to F: EVI-D100/P address + 8

● Error message

When a command or inquiry command could not be executed or failed, an error message is returned instead of the completion message.

Error Packet	Description
X0 6Y 01 FF	Message length error (>14 bytes)
X0 6Y 02 FF	Syntax Error
X0 6Y 03 FF	Command buffer full
X0 6Y 04 FF	Command cancelled
X0 6Y 05 FF	No socket (to be cancelled)
X0 6Y 41 FF	Command not executable

X = 9 to F: EVI-D100/P address + 8, Y = socket number

Socket number

When command messages are sent to the EVI-D100/P, it is normal to send the next command message after waiting for the completion message or error message to return. However to deal with advanced uses, the EVI-D100/P has two buffers (memories) for commands, so that up to two commands including the commands currently being executed can be received. When the EVI-D100/P receives commands, it notifies the sender which command buffer was used using the socket number of the ACK message.

As the completion message or error message also has a socket number, it indicates which command has ended. Even when two command buffers are being used at any one time, an EVI-D100/P management command and some inquiry messages can be executed.

The ACK message is not returned for these commands and inquiries, and only the completion message of socket number 0 is returned.

Command execution cancel

To cancel a command which has already been sent, send the IF_Clear command as the next command. To cancel one of any two commands which have been sent, use the cancel message.

	Cancel Packet	Note
Cancel	8X 2Y FF	Y = socket number

X = 1 to 7: EVI-D100/P address, Y = socket number

The Command canceled error message will be returned for this command, but this is not a fault. It indicates that the command has been canceled.

VISCA Device Setting Command

Before starting control of the EVI-D100/P, be sure to send the Address command and the IF_Clear command using the broadcast function.

For VISCA network administration

● Address

Sets an address of a peripheral device. Use when initializing the network, and receiving the following network change message.

● Network Change

Sent from the peripheral device to the controller when a device is removed from or added to the network. The address must be re-set when this message is received.

	Packet	Note
Address	88 30 01 FF	Always broadcasted.
Network Change	X0 38 FF	
X = 9 to F: EVI-D100/P address + 8		

VISCA interface command

● IF_Clear

Clears the command buffers in the EVI-D100/P and cancels the command currently being executed.

	Command Packet	Reply Packet	Note
IF_Clear	8X 01 00 01FF	X0 50 FF	
IF_Clear (broadcast)	88 01 00 01 FF	88 01 00 01 FF	
X = 1 to 7: EVI-D100/P address (For inquiry packet)			
X = 9 to F: EVI-D100/P address +8 (For reply packet)			

VISCA interface and inquiry

● IF_DeviceTypeInq

Returns information on the VISCA interface.

Inquiry	Inquiry Packet	Reply Packet	Description
IF_DeviceTypeInq	8X 09 00 02 FF	Y0 50 GG GG HH HH JJ JJ KK FF	GGGG = Vender ID (0020: Sony) HHHH = Model ID 0402: EVI-D30/D31 (When the D30/D31 mode is set to ON) 040D: EVI-D100/P JJJJ = ROM revision KK = Maximum socket # (02)

X = 1 to 7: EVI-D100/P address (For inquiry packet)

X = 9 to F: EVI-D100/P address +8 (For reply packet)

Pin assignment

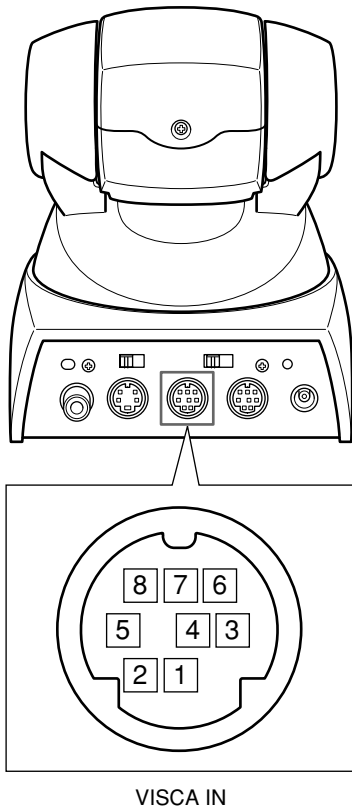

No	Pins	Signals
1	DTR	DataTransmission Ready (OUTPUT)
2	DSR	Data Set Ready (INPUT)
3	TXD	Transmit Data (OUTPUT)
4	GND	Ground
5	RXD	Receive Data (INPUT)
6	GND	Ground
7	IR OUT	IR Commander Signal (OUTPUT)
8	N.C.	No Connection

IR OUT outputs the signals of the Remote Commander at 0 to 5 V when the IR OUT switch is set to ON. When the switch is set to OFF, signals input to the VISCA IN jack are output through the VISCA OUT jack.

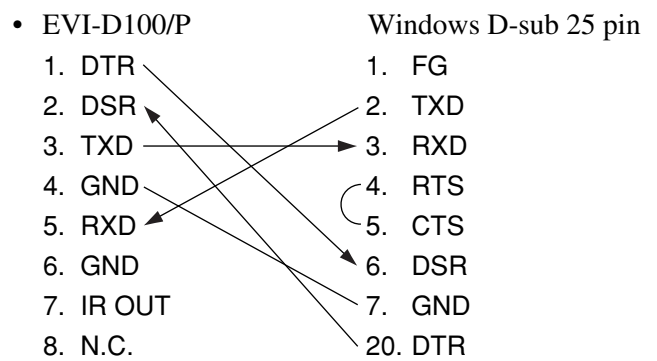
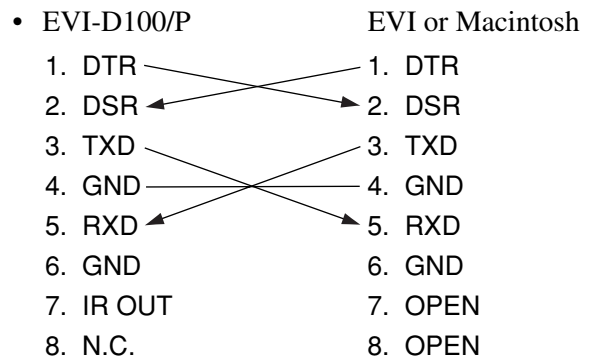
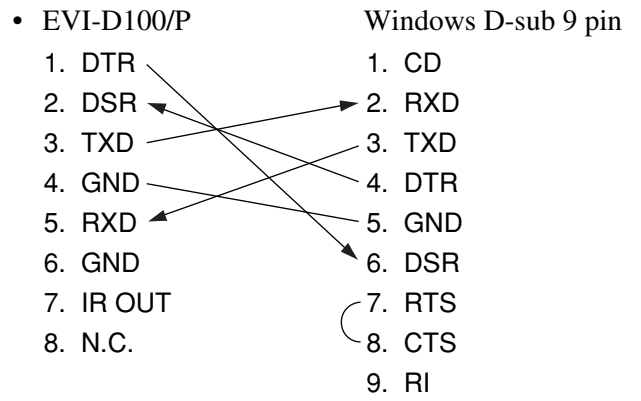

VISCA Command/ACK Protocol

Command	Command Message	Reply Message	Comments
General Command	81 01 04 38 02 FF (Example)	90 41 FF (ACK)+90 51 FF (Completion) 90 42 FF 90 52 FF	Returns ACK when a command has been accepted, and Completion when a command has been executed.
	81 01 04 38 FF (Example)	90 60 02 FF (Syntax Error)	Accepted a command which is not supported or a command lacking parameters.
	81 01 04 38 02 FF (Example)	90 60 03 FF (Command Buffer Full)	There are two commands currently being executed, and the command could not be accepted.
	81 01 04 08 02 FF (Example)	90 61 41 FF (Command Not Executable) 90 62 41 FF	Could not execute the command in the current mode.
Inquiry Command	81 09 04 38 FF (Example)	90 50 02 FF (Completion)	ACK is not returned for the inquiry command.
	81 09 05 38 FF (Example)	90 60 02 FF (Syntax Error)	Accepted an incompatible command.
Address Set	88 30 01 FF	88 30 02 FF	Returned the device address to +1.
IF_Clear(Broadcast)	88 01 00 01 FF	88 01 00 01 FF	Returned the same command.
IF_Clear (For x)	8x 01 00 01 FF	z0 50 FF (Completion)	ACK is not returned for this command.
Command Cancel	8x 2y FF	z0 6y 04 FF (Command Canceled)	Returned when the command of the socket specified is canceled. Completion for the command canceled is not returned.
		z0 6y 05 FF (No Socket)	Returned when the command of the specified socket has already been completed or when the socket number specified is wrong.

VISCA Camera-Issued Messages

ACK/Completion Messages

	Command Messages	Comments
ACK	z0 4y FF (y:Socket No.)	Returned when the command is accepted.
Completion	z0 5y FF (y:Socket No.)	Returned when the command has been executed.

z = Device address + 8

Error Messages

	Command Messages	Comments
Syntax Error	z0 60 02 FF	Returned when the command format is different or when a command with illegal command parameters is accepted.
Command Buffer Full	z0 60 03 FF	Indicates that two sockets are already being used (executing two commands) and the command could not be accepted when received.
Command Canceled	z0 6y 04 FF (y:Socket No.)	Returned when a command which is being executed in a socket specified by the cancel command is canceled. The completion message for the command is not returned.
No Socket	z0 6y 05 FF (y:Socket No.)	Returned when no command is executed in a socket specified by the cancel command, or when an invalid socket number is specified.
Command Not Executable	z0 6y 41 FF (y:Socket No.)	Returned when a command cannot be executed due to current conditions. For example, when commands controlling the focus manually are received during auto focus.

Network Change Message

	Command Message	Comments
Network Change	z0 38 FF	Issued when power is being routed to the camera, or when the VISCA device is connected to or disconnected from the VISCA OUT jack.

EVI-D100/P Commands

EVI-D100/P Command List (1/4)

Command Set	Command	Command Packet	Comments
AddressSet	Broadcast	88 30 01 FF	
IF_Clear	Broadcast	88 01 00 01 FF	
CommandCancel		8x 2p FF	p: Socket No. (=1 or 2)
CAM_Power	On	8x 01 04 00 02 FF	Power ON/OFF (Standby)
	Off (Standby)	8x 01 04 00 03 FF	
CAM_AutoPowerOff	Direct	8x 01 04 40 0p 0q 0r 0s FF	Auto Power Off pqrs: Power Off Timer 0000 (Timer Off) to FFFF (65535min) Initial value: 0000 The power automatically turns off if the camera does not receive any VISCA commands or any signals from the Remote Commander for the duration you set in the timer.
CAM_Zoom	Stop	8x 01 04 07 00 FF	Zoom control
	Tele (Standard)	8x 01 04 07 02 FF	
	Wide (Standard)	8x 01 04 07 03 FF	
	Tele (Variable)	8x 01 04 07 2p FF	p = Speed parameter, 0 (Low) to 7 (High), 8 steps
	Wide (Variable)	8x 01 04 07 3p FF	
	Direct	8x 01 04 47 0p 0q 0r 0s FF	pqrs: Zoom Position Optical zoom: 0000 (wide) to 4000 (tele) Digital zoom: 4000 (×1) to 7000 (×4)
	D-Zoom On	8x 01 04 06 02 FF	Digital zoom ON/OFF
	D-Zoom Off	8x 01 04 06 03 FF	
CAM_Focus	Stop	8x 01 04 08 00 FF	Focus control
	Far (Standard)	8x 01 04 08 02 FF	
	Near (Standard)	8x 01 04 08 03 FF	
	Far (Variable)	8x 01 04 08 2p FF	p = Speed parameter, 0 (Low) to 7 (High), 8 steps
	Near (Variable)	8x 01 04 08 3p FF	
	Direct	8x 01 04 48 0p 0q 0r 0s FF	pqrs: Focus Position 1000 (Far) to 8400 (Near)
	Auto Focus	8x 01 04 38 02 FF	AF ON/OFF
	Manual Focus	8x 01 04 38 03 FF	
	Auto/Manual	8x 01 04 38 10 FF	
	One Push Trigger	8x 01 04 18 01 FF	One push AF trigger
	Infinity	8x 01 04 18 02 FF	Forced infinity
	AF Sens High	8x 01 04 58 02 FF	AF sensitivity High/Low
	AF Sens Low	8x 01 04 58 03 FF	
	Near Limit	8x 01 04 28 0p 0q 0r 0s FF	pqrs: Focus Near Limit Position 1000 (Far) to 8400 (Near)
CAM_WB	Auto	8x 01 04 35 00 FF	Normal Auto
	Indoor	8x 01 04 35 01 FF	Indoor mode
	Outdoor	8x 01 04 35 02 FF	Outdoor mode
	One Push WB	8x 01 04 35 03 FF	One push WB mode
	ATW	8x 01 04 35 04 FF	Auto tracing white balance
	Manual	8x 01 04 35 05 FF	Manual control mode
	One Push Trigger	8x 01 04 10 05 FF	One push WB trigger
CAM_RGain	Reset	8x 01 04 03 00 FF	Manual control of R Gain
	Up	8x 01 04 03 02 FF	
	Down	8x 01 04 03 03 FF	
	Direct	8x 01 04 43 0p 0q 0r 0s FF	pqrs: R Gain 0000 to 00ff, 256 steps

EVI-D100/P Command List (2/4)

Command Set	Command	Command Packet	Comments
CAM_BGain	Reset	8x 01 04 04 00 FF	Manual control of B Gain
	Up	8x 01 04 04 02 FF	
	Down	8x 01 04 04 03 FF	
	Direct	8x 01 04 44 0p 0q 0r 0s FF	pqrs: B Gain 0000 to 00ff, 256 steps
CAM_AE	Full Auto	8x 01 04 39 00 FF	Automatic exposure mode
	Manual	8x 01 04 39 03 FF	Manual control mode
	Shutter Priority	8x 01 04 39 0A FF	Shutter priority automatic exposure mode
	Iris Priority	8x 01 04 39 0B FF	Iris priority automatic exposure mode
	Gain Priority	8x 01 04 39 0C FF	Gain priority automatic exposure mode
	Bright	8x 01 04 39 0D FF	Bright mode (Manual control)
	Shutter Auto	8x 01 04 39 1A FF	Automatic shutter mode
	Iris Auto	8x 01 04 39 1B FF	Automatic iris mode
CAM_SlowShutter	Auto	8x 01 04 5A 02 FF	Slow shutter Auto/Manual
	Manual	8x 01 04 5A 03 FF	
CAM_Shutter	Reset	8x 01 04 0A 00 FF	Shutter setting
	Up	8x 01 04 0A 02 FF	
	Down	8x 01 04 0A 03 FF	
	Direct	8x 01 04 4A 0p 0q 0r 0s FF	pqrs: Shutter Position 0000 (NTSC 1/4, PAL 1/3) to 0013 (1/10000 sec.), 20 steps
CAM_Iris	Reset	8x 01 04 0B 00 FF	Iris setting
	Up	8x 01 04 0B 02 FF	
	Down	8x 01 04 0B 03 FF	
	Direct	8x 01 04 4B 0p 0q 0r 0s FF	pqrs: Iris Position 0000(close) to 0011(F1.8), 18 steps
CAM_Gain	Reset	8x 01 04 0C 00 FF	Gain setting
	Up	8x 01 04 0C 02 FF	
	Down	8x 01 04 0C 03 FF	
	Direct	8x 01 04 4C 0p 0q 0r 0s FF	pqrs: Gain Position 0000(-3 dB) to 0007(+18 dB), 8 steps
CAM_Bright	Reset	8x 01 04 0D 00 FF	Bright setting
	Up	8x 01 04 0D 02 FF	
	Down	8x 01 04 0D 03 FF	
	Direct	8x 01 04 4D 0p 0q 0r 0s FF	pqrs: Bright Position 0000 (close,0 dB) to 0017(F1.8,+18 dB), 24 steps at 3 dB
CAM_ExpComp	On	8x 01 04 3E 02 FF	Exposure compensation ON/OFF
	Off	8x 01 04 3E 03 FF	
	Reset	8x 01 04 0E 00 FF	Exposure compensation amount setting
	Up	8x 01 04 0E 02 FF	
	Down	8x 01 04 0E 03 FF	
	Direct	8x 01 04 4E 0p 0q 0r 0s FF	pqrs: ExpComp Position 0000(-10.5 dB) to 000E(10.5 dB), 15 steps at 1.5 dB
CAM_BackLight	On	8x 01 04 33 02 FF	Back light compensation ON/OFF
	Off	8x 01 04 33 03 FF	

EVI-D100/P Command List (3/4)

Command Set	Command	Command Packet	Comments
CAM_Aperture	Reset	8x 01 04 02 00 FF	Aperture control
	Up	8x 01 04 02 02 FF	
	Down	8x 01 04 02 03 FF	
	Direct	8x 01 04 42 0p 0q 0r 0s FF	pqrs: Aperture Gain 0000 to 000f, 16 steps, Initial value: 5
CAM_Wide	Off	8x 01 04 60 00 FF	Wide mode setting
	Cinema	8x 01 04 60 01 FF	
	16:9 Full	8x 01 04 60 02 FF	
CAM_LR_Reverse	On	8x 01 04 61 02 FF	Mirror image ON/OFF
	Off	8x 01 04 61 03 FF	
CAM_Freeze	On	8x 01 04 62 02 FF	Still image ON/OFF
	Off	8x 01 04 62 03 FF	
CAM_PictureEffect	Off	8x 01 04 63 00 FF	Picture effect setting
	Pastel	8x 01 04 63 01 FF	
	NegArt	8x 01 04 63 02 FF	
	Sepia	8x 01 04 63 03 FF	
	B&W	8x 01 04 63 04 FF	
	Solarize	8x 01 04 63 05 FF	
	Mosaic	8x 01 04 63 06 FF	
	Slim	8x 01 04 63 07 FF	
Stretch	8x 01 04 63 08 FF		
CAM_DigitalEffect	Off	8x 01 04 64 00 FF	Digital effect setting
	Still	8x 01 04 64 01 FF	
	Flash	8x 01 04 64 02 FF	
	Lumi.	8x 01 04 64 03 FF	
	Trail	8x 01 04 64 04 FF	
	EffectLevel	8x 01 04 65 pp FF	pp: Effect Level 00 to 18(Flash,Trail), 00 to 20 (Still, Lumi.)
CAM_Memory	Reset	8x 01 04 3F 00 0p FF	p: Memory Number (= 0 to 5)
	Set	8x 01 04 3F 01 0p FF	
	Recall	8x 01 04 3F 02 0p FF	
Datascreen	On	8x 01 06 06 02 FF	Display ON/OFF
	Off	8x 01 06 06 03 FF	
	On/Off	8x 01 06 06 10 FF	
IR_Receive	On	8x 01 06 08 02 FF	IR(remote controller) receive ON/OFF
	Off	8x 01 06 08 03 FF	
	On/Off	8x 01 06 08 10 FF	
IR_ReceiveReturn	On	8x 01 7D 01 03 00 00 FF	IR(remote controller) receive message ON/OFF
	Off	8x 01 7D 01 13 00 00 FF	

EVI-D100/P Command List (4/4)

Command Set	Command	Command Packet	Comments
Pan-tiltDrive	Up	8x 01 06 01 VV WW 03 01 FF	VV: Pan speed 01 to 18
	Down	8x 01 06 01 VV WW 03 02 FF	WW: Tilt Speed 01 to 14
	Left	8x 01 06 01 VV WW 01 03 FF	YYYY: Pan Position FA60 to 05A0 (center 0000)
	Right	8x 01 06 01 VV WW 02 03 FF	ZZZZ: Tilt Position FE98 to 0168 (center 0000)
	UpLeft	8x 01 06 01 VV WW 01 01 FF	
	UpRight	8x 01 06 01 VV WW 02 01 FF	
	DownLeft	8x 01 06 01 VV WW 01 02 FF	
	DownRight	8x 01 06 01 VV WW 02 02 FF	
	Stop	8x 01 06 01 VV WW 03 03 FF	
	AbsolutePosition	8x 01 06 02 VV WW 0Y 0Y 0Y 0Y 0Z 0Z 0Z 0Z FF	
	RelativePosition	8x 01 06 03 VV WW 0Y 0Y 0Y 0Y 0Z 0Z 0Z 0Z FF	
	Home	8x 01 06 04 FF	
	Reset	8x 01 06 05 FF	
Pan-tiltLimitSet	LimitSet	8x 01 06 07 00 0W 0Y 0Y 0Y 0Y 0Z 0Z 0Z 0Z FF	W: 1 UpRight, 0 DownLeft YYYY: Pan Limit Position FA60 to 05A0 (center 0000)
	LimitClear	8x 01 06 07 01 0W 07 0F 0F 0F 07 0F 0F 0F FF	ZZZZ: Tilt Limit Position FE98 to 0168 (center 0000)

EVI-D100/P Inquiry Command List (1/2)

InquiryCommand	CommandPacket	InquiryPacket	Comments
CAM_PowerInq	8x 09 04 00 FF	y0 50 02 FF	On
		y0 50 03 FF	Off (Standby)
CAM_AutoPowerOffInq	8x 09 04 40 FF	y0 50 0p 0q 0r 0s FF	pqrs: PowerOff Timer
CAM_DZoomModeInq	8x 09 04 06 FF	y0 50 02 FF	Digital Zoom On
		y0 50 03 FF	Digital Zoom Off
CAM_ZoomPosInq	8x 09 04 47 FF	y0 50 0p 0q 0r 0s FF	pqrs: Zoom Position
CAM_FocusModeInq	8x 09 04 38 FF	y0 50 02 FF	Auto Focus On
		y0 50 03 FF	Auto Focus Off
CAM_FocusPosInq	8x 09 04 48 FF	y0 50 0p 0q 0r 0s FF	pqrs: Focus Position
CAM_AFMModeInq	8x 09 04 58 FF	y0 50 02 FF	AF Sens High
		y0 50 03 FF	AF Sens Low
CAM_FocusNearLimitInq	8x 09 04 28 FF	y0 50 0p 0q 0r 0s FF	pqrs: Focus Limit Position
CAM_WBModeInq	8x 09 04 35 FF	y0 50 00 FF	Auto
		y0 50 01 FF	Indoor
		y0 50 02 FF	Outdoor
		y0 50 03 FF	OnePush
		y0 50 04 FF	ATW
		y0 50 05 FF	Manual
CAM_RGainInq	8x 09 04 43 FF	y0 50 0p 0q 0r 0s FF	pqrs: R Gain
CAM_BGainInq	8x 09 04 44 FF	y0 50 0p 0q 0r 0s FF	pqrs: B Gain
CAM_AEModeInq	8x 09 04 39 FF	y0 50 00 FF	Full Auto
		y0 50 03 FF	Manual
		y0 50 0A FF	Shutter Priority
		y0 50 0B FF	Iris Priority
		y0 50 0C FF	Gain Priority
		y0 50 0D FF	Bright
		y0 50 1A FF	Shutter Auto
		y0 50 1B FF	Iris Auto
		y0 50 1C FF	Gain Auto
CAM_SlowShutterModeInq	8x 09 04 5A FF	y0 50 02 FF	Auto
		y0 50 03 FF	Manual
CAM_ShutterPosInq	8x 09 04 4A FF	y0 50 0p 0q 0r 0s FF	pqrs: Shutter Position
CAM_IrisPosInq	8x 09 04 4B FF	y0 50 0p 0q 0r 0s FF	pqrs: Iris Position
CAM_GainPosInq	8x 09 04 4C FF	y0 50 0p 0q 0r 0s FF	pqrs: Gain Position
CAM_BrightPosInq	8x 09 04 4D FF	y0 50 0p 0q 0r 0s FF	pqrs: Bright Position

EVI-D100/P Inquiry Command List (2/2)

InquiryCommand	CommandPacket	InquiryPacket	Comments
CAM_ExpCompModeInq	8x 09 04 3E FF	y0 50 02 FF	On
		y0 50 03 FF	Off
CAM_ExpCompPosInq	8x 09 04 4E FF	y0 50 0p 0q 0r 0s FF	pqrs: ExpCompPosition
CAM_BackLightModeInq	8x 09 04 33 FF	y0 50 02 FF	On
		y0 50 03 FF	Off
CAM_ApertureInq	8x 09 04 42 FF	y0 50 0p 0q 0r 0s FF	pqrs: Aperture Gain
CAM_WideModeInq	8x 09 04 60 FF	y0 50 00 FF	Off
		y0 50 01 FF	Cinema
		y0 50 02 FF	16:9 Full
CAM_LR_ReverseModeInq	8x 09 04 61 FF	y0 50 02 FF	On
		y0 50 03 FF	Off
CAM_FreezeModeInq	8x 09 04 62 FF	y0 50 02 FF	On
		y0 50 03 FF	Off
CAM_PictureEffectModeInq	8x 09 04 63 FF	y0 50 00 FF	Off
		y0 50 01 FF	Pastel
		y0 50 02 FF	NegArt
		y0 50 03 FF	Sepia
		y0 50 04 FF	B&W
		y0 50 05 FF	Solarize
		y0 50 06 FF	Mosaic
		y0 50 07 FF	Slim
		y0 50 08 FF	Stretch
CAM_DigitalEffectModeInq	8x 09 04 64 FF	y0 50 00 FF	Off
		y0 50 01 FF	Still
		y0 50 02 FF	Flash
		y0 50 03 FF	Lumi.
		y0 50 04 FF	Trail
CAM_DigitalEffectLevelInq	8x 09 04 65 FF	y0 50 pp FF	pp: Effect Level
CAM_MemoryInq	8x 09 04 3F FF	y0 50 0p FF	p: Last Access Memory No.
DatascreeInq	8x 09 06 06 FF	y0 50 02 FF	On
		y0 50 03 FF	Off
Pan-tiltModeInq	8x 09 06 10 FF	y0 50 pq rs FF	pqrs: Pan/Filter Status
Pan-tiltMaxSpeedInq	8x 09 06 11 FF	y0 50 ww zz FF	ww = Pan Max Speed zz = Tilt Max Speed
Pan-tiltPosInq	8x 09 06 12 FF	y0 50 0w 0w 0w 0w 0z 0z 0z 0z FF	www = Pan Position zzzz = Tilt Position
VideoSystemInq	8x 09 06 23 FF	y0 50 00 FF	NTSC
		y0 50 01 FF	PAL
CAM_DeviceTypeInq / VersionInq	8x 09 00 02 FF	y0 50 gg gg hh hh jj kk FF	gggg = Vender ID (0001:Sony) hhhh = Model ID jjjj = ROM Version kk = Socket Number (=2)
IR_ReceiveReturn		y0 07 7D 01 04 00 FF	Power ON/OFF
		y0 07 7D 01 04 07 FF	Zoom tele/wide
		y0 07 7D 01 04 38 FF	AF On/Off
		y0 07 7D 01 04 33 FF	CAM_Backlight
		y0 07 7D 01 04 3F FF	CAM_Memory
		y0 07 7D 01 06 01 FF	Pan_tiltDrive

EVI-D100/P Block Inquiry Command List

Lens control system inquiry commands (1/2) Command Packet 8x 09 7E 7E 00 FF

Byte	Bit	Comments
0	7	y0
	6	
	5	
	4	
	3	
	2	
	1	
	0	
1	7	50
	6	
	5	
	4	
	3	
	2	
	1	
	0	
2	7	0
	6	0
	5	0
	4	0
	3	Zoom Position (HH)
	2	
	1	
	0	
3	7	
	6	0
	5	0
	4	0
	3	Zoom Position (HL)
	2	
	1	
	0	
4	7	
	6	0
	5	0
	4	0
	3	Zoom Position (LH)
	2	
	1	
	0	
5	7	
	6	0
	5	0
	4	0
	3	Zoom Position (LL)
	2	
	1	
	0	

Byte	Bit	Comments
6	7	0
	6	0
	5	0
	4	0
	3	Focus Near Limit (H)
	2	
	1	
	0	
7	7	
	6	0
	5	0
	4	0
	3	Focus Near Limit (L)
	2	
	1	
	0	
8	7	
	6	0
	5	0
	4	0
	3	Focus Position (HH)
	2	
	1	
	0	
9	7	
	6	0
	5	0
	4	0
	3	Focus Position (HL)
	2	
	1	
	0	
10	7	
	6	0
	5	0
	4	0
	3	Focus Position (LH)
	2	
	1	
	0	
11	7	
	6	0
	5	0
	4	0
	3	Focus Position (LL)
	2	
	1	
	0	

Lens control system inquiry commands (2/2) Command Packet 8x 09 7E 7E 00 FF

Byte	Bit	Comments
12	7	0
	6	0
	5	0
	4	0
	3	0
	2	0
	1	0
	0	0
13	7	0
	6	0
	5	0
	4	0
	3	0
	2	AF Sens 1:High 0:Low
	1	Digital Zoom 1:On 0:Off
	0	Focus Mode 1:Auto 0:Manual
14	7	0
	6	0
	5	0
	4	0
	3	0
	2	0
	1	Focus Command 1:Executing 0: Stopped
	0	Zoom Command 1:Executing 0: Stopped
15	7	FF
	6	
	5	
	4	
	3	
	2	
	1	
	0	

Camera control system inquiry commands (1/2) .. Command Packet 8x 09 7E 7E 01 FF

Byte	Bit	Comments
0	7	y0
	6	
	5	
	4	
	3	
	2	
	1	
	0	
1	7	50
	6	
	5	
	4	
	3	
	2	
	1	
	0	
2	7	0
	6	0
	5	0
	4	0
	3	R Gain (H)
	2	
	1	
	0	
3	7	
	6	0
	5	0
	4	0
	3	R Gain (L)
	2	
	1	
	0	
4	7	
	6	0
	5	0
	4	0
	3	B Gain (H)
	2	
	1	
	0	
5	7	
	6	0
	5	0
	4	0
	3	B Gain (L)
	2	
	1	
	0	

Byte	Bit	Comments
6	7	0
	6	0
	5	0
	4	0
	3	0
	2	WB Mode 0:Auto 1:Indoor 2:Outdoor 3:OnePushWB 4:ATW 5:Manual
	1	
	0	
7	7	0
	6	0
	5	0
	4	0
	3	Aperture Gain
	2	
	1	
	0	
8	7	
	6	0
	5	0
	4	Exposure Mode 00:Full Auto 03:Manual 0A:ShutterPriority 0B:IrisPriority 0C:GainPriority 0D:Bright 1A:ShutterAuto 1B:IrisAuto 1C:GainAuto
	3	
	2	
	1	
	0	1A:ShutterAuto 1B:IrisAuto 1C:GainAuto
9	7	0
	6	Gain Command 1:Valid 0:Invalid
	5	Iris Command 1:Valid 0:Invalid
	4	Shutter Command 1:Valid 0:Invalid
	3	Bright Command 1:Valid 0:Invalid
	2	Back Light 1:On 0:Off
	1	Exposure Comp. 1:On 0:Off
	0	Slow Shutter 1:Auto 0:Manual
10	7	0
	6	0
	5	0
	4	Shutter Position
	3	
	2	
	1	
	0	
11	7	0
	6	0
	5	0
	4	0
	3	Iris Position
	2	
	1	
	0	

Camera control system inquiry commands (2/2) .. Command Packet 8x 09 7E 7E 01 FF

Byte	Bit	Comments
12	7	0
	6	0
	5	0
	4	0
	3	0
	2	Gain Position
	1	
	0	
0		
13	7	0
	6	0
	5	0
	4	Bright Position
	3	
	2	
	1	
	0	
14	7	0
	6	0
	5	0
	4	0
	3	Exposure Comp. Position
	2	
	1	
	0	
0		
15	7	FF
	6	
	5	
	4	
	3	
	2	
	1	
	0	

Other inquiry commands (1/2) Command Packet 8x 09 7E 7E 02 FF

Byte	Bit	Comments
0	7	y0
	6	
	5	
	4	
	3	
	2	
	1	
	0	
1	7	50
	6	
	5	
	4	
	3	
	2	
	1	
	0	
2	7	0
	6	0
	5	0
	4	0
	3	0
	2	0
	1	0
	0	Power 1:On 0:Off
3	7	0
	6	0
	5	0
	4	0
	3	Freeze 1:On 0:Off
	2	LR Reverse 1:On 0:Off
	1	Wide 16:9 Full 1:On 0:Off
	0	Wide Cinema 1:On 0:Off
4	7	0
	6	0
	5	0
	4	0
	3	0
	2	Data screen 1:On, 0:Off
	1	0
	0	0
5	7	0
	6	0
	5	0
	4	0
	3	0
	2	Picture Effect Mode
	1	0:Off 1:Pastel 2:Neg.Art 3:Sepia 4:B&W
	0	5:Solarize 6:Mosaic 7:Slim 8:Stretch

Byte	Bit	Comments
6	7	0
	6	0
	5	0
	4	0
	3	0
	2	Digital Effect Mode 0:Off 1:Still 2:Flash 3:Lumi. 4:Trail
	1	
	0	
7	7	0
	6	0
	5	0
	4	Digital Effect Level
	3	
	2	
	1	
	0	
8	7	0
	6	0
	5	0
	4	0
	3	0
	2	0
	1	0
	0	0
9	7	0
	6	0
	5	0
	4	0
	3	0
	2	0
	1	0
	0	0
10	7	0
	6	0
	5	0
	4	0
	3	0
	2	0
	1	0
	0	0
11	7	0
	6	0
	5	0
	4	0
	3	0
	2	0
	1	0
	0	0

Other inquiry commands (2/2) Command Packet 8x 09 7E 7E 02 FF

Byte	Bit	Comments
12	7	0
	6	0
	5	0
	4	0
	3	0
	2	0
	1	0
	0	System 1:PAL 0:NTSC
13	7	0
	6	0
	5	0
	4	0
	3	0
	2	0
	1	0
	0	0
14	7	0
	6	0
	5	0
	4	0
	3	0
	2	0
	1	0
	0	0
15	7	FF
	6	
	5	
	4	
	3	
	2	
	1	
	0	

VISCA Command Setting Values

Exposure control

		NTSC	PAL
Shutter Speed	13	10000	10000
	12	6000	6000
	11	4000	3500
	10	3000	2500
	0F	2000	1750
	0E	1500	1250
	0D	1000	1000
	0C	725	600
	0B	500	425
	0A	350	300
	09	250	215
	08	180	150
	07	125	120
	06	100	100
	05	90	75
	04	60	50
	03	30	25
	02	15	12
	01	8	6
	00	4	3
Iris	11	F1.8	
	10	F2	
	0F	F2.4	
	0E	F2.8	
	0D	F3.4	
	0C	F4	
	0B	F4.8	
	0A	F5.6	
	09	F6.8	
	08	F8	
	07	F9.6	
	06	F11	
	05	F14	
	04	F16	
	03	F19	
	02	F22	
	01	F28	
00	CLOSE		
Gain	07	18 dB	
	06	15 dB	
	05	12 dB	
	04	9 dB	
	03	6 dB	
	02	3 dB	
	01	0 dB	
	00	-3 dB	

		NTSC	PAL
Bright	17	F1.8	18 dB
	16	F1.8	15 dB
	15	F1.8	12 dB
	14	F1.8	9 dB
	13	F1.8	6 dB
	12	F1.8	3 dB
	11	F1.8	0 dB
	10	F2	0 dB
	0F	F2.4	0 dB
	0E	F2.8	0 dB
	0D	F3.4	0 dB
	0C	F4	0 dB
	0B	F4.8	0 dB
	0A	F5.6	0 dB
	09	F6.8	0 dB
	08	F8	0 dB
	07	F9.6	0 dB
	06	F11	0 dB
	05	F14	0 dB
	04	F16	0 dB
03	F19	0 dB	
02	F22	0 dB	
01	F28	0 dB	
00	CLOSE	0 dB	
Exposure Comp.	0E	7	10.5 dB
	0D	6	9 dB
	0C	5	7.5 dB
	0B	4	6 dB
	0A	3	4.5 dB
	09	2	3 dB
	08	1	1.5 dB
	07	0	0 dB
	06	-1	-1.5 dB
	05	-2	-3 dB
	04	-3	-4.5 dB
	03	-4	-6 dB
	02	-5	-7.5 dB
	01	-6	-9 dB
00	-7	-10.5 dB	

Zoom values and focal length (for reference)

Zoom values	Focal length ¹⁾ (mm)
0000h	3.1
0E6Dh	4.65
188Eh	6.2
2507h	9.3
2B82h	12.4
3130h	15.5
352Eh	18.6
385Dh	21.7
3B48h	24.8
3E01h	27.9
4000h	31
5000h	41.3
6000h	62
7000h	124

1) Values when an object is 2 m away from the front surface of the lens

Focus values (Focus Near limit values) and object distance (for reference)

Focus value (limit value)	Object distance ¹⁾ (m)
1161h	20
116Dh	18
122Ah	16
123Ch	14
12F3h	12
13C2h	10
151Eh	8
1536h	6
1844h	4
226Fh	2
3F2Ah	1.5
40AAh	1
62C9h	0.5
82C1h	0.1

1) Distance between the front surface of the lens and an object

Lens control

Zoom Position	0000 (Optical Wide end)	to	4000 (Optical Tele end)
	4000 (Digital Zoom ×1)	to	7000 (Digital Zoom ×4)
Focus Position	1000 (Far)	to	8400 (Near)
Focus Near Limit	1000 (Far)	to	8400 (Near)

Note: The lower one byte is fixed at 00.

Others

R,B gain		00~FF
Aperture		00~0F
Effect Level (Digital Effect Level)	STILL	00~20
	FLASH	00~18
	LUMI.	00~20
	TRAIL	00~18

Pan/Tilter Status Code List

P	Q	R	S	
0---	----	0---	---1	Pan has reached the left endpoint.
0---	----	0---	--1-	Pan has reached the right endpoint.
0---	----	0---	-1--	Tilt has reached the top endpoint.
0---	----	0---	1---	Tilt has reached the bottom endpoint.
0---	----	--00	----	Pan is normal.
0---	----	--01	----	Pan has a position detection error.
0---	----	--10	----	Pan has a mechanical problem.
0---	--00	0---	----	Tilt is normal.
0---	--01	0---	----	Tilt has a position detection error.
0---	--10	0---	----	Tilt has a mechanical problem.
0---	00--	0---	----	No movement command
0---	01--	0---	----	Pan-Tilt is moving.
0---	10--	0---	----	Pan-Tilt operation is completed.
0---	11--	0---	----	Pan-Tilt operation failed.
0-00	----	0---	----	Not initialized
0-01	----	0---	----	Initializing
0-10	----	0---	----	Initialization completed
0-11	----	0---	----	Initialization failed

(-: Optional)

D30/D31 Mode

Overview

The D30/D31 mode allows you to control the EVI-D100/P using VISCA commands for the EVI-D30/D31.

Most of the VISCA commands for the EVI-D100/P correspond to one for the EVI-D30/D31. However, some of the VISCA commands for the EVI-D100/P are different from those for the EVI-D30/D31 in definitions of parameters.

When you send those commands to an EVI-D100/P whose D30/D31 mode is set to ON, the camera translates the parameters for the EVI-D30/D31 to those for the EVI-D100/P and executes the command. The following parameters are subject to translation.

- Zoom speed
- Zoom position
- Focus position
- Shutter speed
- Pan-tilt speed
- Pan-tilt position

Notes

- Even if you set the D30/D31 mode to ON, the EVI-D100/P may not emulate the EVI-D30/D31 perfectly. This is caused by differences in hardware between the two models.
- The functions that are provided with the EVI-D30/D31 but not with the EVI-D100/P cannot be executed.

Switching the Mode

You can switch the D30/D31 mode ON or OFF by switching the D30/D31 mode switch at the bottom of the EVI-D100/P. To change the D30/D31 mode setting, move the D30/D31 mode switch to ON or OFF while the camera's power is off or the camera is in standby mode. Then, turn the power on by connecting the camera to an AC outlet or by using the VISCA commands or the Remote Commander. If you change the switch setting while the camera's power is on, the mode of the camera will not change.

At the moment you turn the D30/D31 mode on or off, the data backed up in the camera is erased and the settings return to their initial values.

Accepting or Sending Back Commands

When accepting commands

Type of command		D30/D31 mode on	D30/D31 mode off
Common to both the D30/D31 and D100/P	Common parameters	Accepts as is	
	Different parameters	Translates the D30/D31's parameters to those of the D100/P	Accepts as is
	CAM_Memory Reset	Memorized data items are erased and camera settings return to initial values	Memorized data items are erased
Only for the D100/P		Refuses and sends back the NotExecutable message	Accepts as is
Only for the D30/D31		Refuses and sends back the NotExecutable message	Refuses and sends back the SyntaxError message

When accepting inquiry commands

Type of command		D30/D31 mode on	D30/D31 mode off
Common to both the D30/D31 and D100/P	Common parameters	Sends back parameters common to both the D30/D31 and D100/P	
	Different parameters	Sends back the D30/D31's parameters translated from those of the D100/P	Sends back the D100/P's parameters
Only for the D100/P		Refuses and sends back the NotExecutable message	Sends back the D100/P's parameters
Only for the D30/D31		Refuses and sends back the NotExecutable message	Refuses and sends back the SyntaxError message

Translating Parameters

Zoom speed

Cameras	Parameters
EVI-D30/D31	02h (Min. speed) to 07h (Max. speed)
EVI-D100/P	00h (Min. speed) to 07h (Max. speed)

Translation of commands

Accepted parameters	Translation
00h, 01h	Translates to 02h
Values greater than 02h	Accepts as is

Zoom position

Cameras	Parameters
EVI-D30/D31	0000h (WIDE) to 03FFh (TELE)
EVI-D100/P	0000h (WIDE) to 7000h (TELE, digital 4x)

Translation of commands

Accepted parameters	Translation
0000h to 03FFh	Translates within a range of 08D0h to 5700h

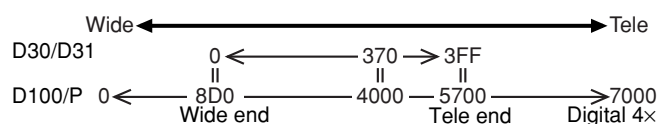

The EVI-D100/P translates the parameters to let the camera obtain the same zoom position that is defined by the D30/D31's parameter.

The digital zoom function is always set to ON.

However, when you use the CAM_Zoom Tele/Wide command or the Remote Commander, the available zoom range is equal to the zoom range of the EVI-D100/P (0000h to 7000h).

Translation when answering inquiry commands

Parameters	Translation
0000h to 7000h	Translates within a range of 0000h to 03FFh

The D100/P's parameters are translated to those of the D30/D31.

However, even if the zoom position value is less than 08D0h (closer to the wide side), the camera sends back 0000h to the controller. On the other hand, even if that value is greater than 5700h (closer to the telephoto side), the camera sends back 03FFh.

Focus position

Cameras	Parameters
EVI-D30/D31	1000h (FAR) to 9FFFh (NEAR, 1 cm)
EVI-D100/P	1000h (FAR) to 8400h (NEAR, 10 cm)

Translation of commands

Accepted parameters	Translation
Values less than 8400h	Accepts as is
Values greater than 8400h	Translates to 8400h

The actual focus position does not match the value that is defined by the D30/D31's parameters.

Translation when answering inquiry commands

Parameters	Translation
1000h to 8400h	Sends back parameters as is

During the period from the instant the camera accepts the CAM_Focus Direct command at a value greater than 8400h to the instant the camera accepts another command to define the focus position, it sends back the current D30/D31 parameters.

Shutter speed

Translation of commands

The EVI-D100/P translates the D30/D31's parameters to D100/P parameters in accordance with the table below.

NTSC

EVI-D30			EVI-D100	
Parameters	Shutter speed		Parameters	Shutter speed
0000h	(1/60)	➔	0004h	(1/60)
0001h	(1/60)	➔	0004h	(1/60)
0002h	(1/75)	➔	0004h	(1/60)
0003h	(1/90)	➔	0005h	(1/90)
0004h	(1/100)	➔	0006h	(1/100)
0005h	(1/125)	➔	0007h	(1/125)
0006h	(1/150)	➔	0007h	(1/125)
0007h	(1/180)	➔	0008h	(1/180)
0008h	(1/215)	➔	0008h	(1/180)
0009h	(1/250)	➔	0009h	(1/250)
000Ah	(1/300)	➔	0009h	(1/250)
000Bh	(1/350)	➔	000Ah	(1/350)
000Ch	(1/425)	➔	000Ah	(1/350)
000Dh	(1/500)	➔	000Bh	(1/500)
000Eh	(1/600)	➔	000Bh	(1/500)
000Fh	(1/725)	➔	000Ch	(1/725)
0010h	(1/850)	➔	000Ch	(1/725)
0011h	(1/1000)	➔	000Dh	(1/1000)
0012h	(1/1250)	➔	000Dh	(1/1000)
0013h	(1/1500)	➔	000Eh	(1/1500)
0014h	(1/1750)	➔	000Eh	(1/1500)
0015h	(1/2000)	➔	000Fh	(1/2000)
0016h	(1/2500)	➔	000Fh	(1/2000)
0017h	(1/3000)	➔	0010h	(1/3000)
0018h	(1/3500)	➔	0010h	(1/3000)
0019h	(1/4000)	➔	0011h	(1/4000)
001Ah	(1/6000)	➔	0012h	(1/6000)
001Bh	(1/10000)	➔	0013h	(1/10000)

PAL

EVI-D31			EVI-D100P	
Parameters	Shutter speed		Parameters	Shutter speed
0000h	(1/50)	➔	0004h	(1/50)
0001h	(1/60)	➔	0004h	(1/50)
0002h	(1/75)	➔	0005h	(1/75)
0003h	(1/90)	➔	0006h	(1/100)
0004h	(1/100)	➔	0006h	(1/100)
0005h	(1/120)	➔	0007h	(1/120)
0006h	(1/150)	➔	0008h	(1/150)
0007h	(1/180)	➔	0008h	(1/150)
0008h	(1/215)	➔	0009h	(1/215)
0009h	(1/250)	➔	0009h	(1/215)
000Ah	(1/300)	➔	000Ah	(1/300)
000Bh	(1/350)	➔	000Ah	(1/300)
000Ch	(1/425)	➔	000Bh	(1/425)
000Dh	(1/500)	➔	000Bh	(1/425)
000Eh	(1/600)	➔	000Ch	(1/600)
000Fh	(1/725)	➔	000Ch	(1/600)
0010h	(1/850)	➔	000Dh	(1/1000)
0011h	(1/1000)	➔	000Dh	(1/1000)
0012h	(1/1250)	➔	000Eh	(1/1250)
0013h	(1/1500)	➔	000Eh	(1/1250)
0014h	(1/1750)	➔	000Fh	(1/1750)
0015h	(1/2000)	➔	000Fh	(1/1750)
0016h	(1/2500)	➔	0010h	(1/2500)
0017h	(1/3000)	➔	0010h	(1/2500)
0018h	(1/3500)	➔	0011h	(1/3500)
0019h	(1/4000)	➔	0011h	(1/3500)
001Ah	(1/6000)	➔	0012h	(1/6000)
001Bh	(1/10000)	➔	0013h	(1/10000)

Translation when answering inquiry commands

The EVI-D100/P translates its parameters to the D30/D31's parameters and sends them back. However, during the period from the instant the camera accepts the CAM_Shutter Direct command to the instant the camera accepts another CAM_Shutter or CAM_AE command, it sends back the current D30/D31 parameters.

Pan/tilt speed

The actual speed that is defined by the parameters corresponds to that of the EVI-D30/D31.

When the camera accepts commands such as Pan-tiltDrive Home, Reset, or CAM_Memory Recall, the operation speed is equal to the speed when the D30/D31 mode is OFF.

Pan

Parameters	Speed (deg/sec)		
	D100/P		D30/D31
01h	2.0	➔	3.3
02h	2.4	➔	6.7
03h	3.0	➔	10.0
04h	3.7	➔	13.3
05h	4.7	➔	16.7
06h	6.1	➔	20.0
07h	7.4	➔	23.3
08h	9.1	➔	26.7
09h	11	➔	30.0
0Ah	14	➔	33.3
0Bh	18	➔	36.7
0Ch	22	➔	40.0
0Dh	27	➔	43.3
0Eh	34	➔	46.7
0Fh	42	➔	50.0
10h	52	➔	53.3
11h	65	➔	56.7
12h	81	➔	60.0
13h	100	➔	63.3
14h	125	➔	66.7
15h	155	➔	70.0
16h	190	➔	73.3
17h	240	➔	76.7
18h	300	➔	80.0

Tilt

Parameters	Speed (deg/sec)		
	D100/P		D30/D31
01h	2.0	➔	2.5
02h	2.4	➔	5.0
03h	3.0	➔	7.5
04h	3.7	➔	10.0
05h	4.7	➔	12.5
06h	6.1	➔	15.0
07h	7.4	➔	17.5
08h	9.1	➔	20.0
09h	11	➔	22.5
0Ah	14	➔	25.0
0Bh	18	➔	27.5
0Ch	22	➔	30.0
0Dh	27	➔	32.5
0Eh	34	➔	35.0
0Fh	42	➔	37.5
10h	52	➔	40.0
11h	65	➔	42.5
12h	81	➔	45.0
13h	100	➔	47.5
14h	125	➔	50.0

Pan/tilt position

Pan position

Cameras	Parameters
EVI-D30/D31	FC90h (-100 degrees) to 0370h (+100 degrees)
EVI-D100/P	FA60h (-100 degrees) to 05A0h (+100 degrees)

Tilt position

Cameras	Parameters
EVI-D30/D31	FED4h (-25 degrees) to 012Ch (+25 degrees)
EVI-D100/P	FE98h (-25 degrees) to 0168h (+25 degrees)

Translation of commands

Accepting parameters	Translation
Pan position	Multiplies received parameters by 18/11
Tilt position	Multiplies received parameters by 6/5

D30/D31		D100/P	
Pan/Tilt		Pan	Tilt
FC90h	➔	FA60h	-
...		...	-
FED4h	➔	FE15h	FE98h
...	
FFFDh	➔	FFFBh	FFFCh
FFFEh	➔	FFFDh	FFFEh
FFFFh	➔	FFFEh	FFFFh
0000h	➔	0000h	0000h
0001h	➔	0002h	0001h
0002h	➔	0003h	0002h
0003h	➔	0005h	0004h
0004h	➔	0007h	0005h
0005h	➔	0008h	0006h
0006h	➔	000Ah	0007h
0007h	➔	000Bh	0008h
0008h	➔	000Dh	0009h
0009h	➔	000Fh	000Bh
000Ah	➔	0010h	000Ch
000Bh	➔	0012h	000Dh
...	
012Ch	➔	01EBh	0168h
...		...	-
0370h	➔	05A0h	-

Translation when answering inquiry commands

The camera sends back values that are calculated by inverse conversion performed when the camera accepts commands.

Note

Repetitive use of the Relative position command may increase the variance that is accumulated from translation.

Example

When you execute the Relative position command 88 times, one step after another to turn the camera to the right side:

Cameras	Results
EVI-D30/D31	Turns to the right side by 10 degrees.
EVI-D100/P whose D30/D31 mode is ON	Turns to the right side by 12.2 degrees.

Specifications

System

Video signal	EVI-D100: NTSC Color, JEITA standards EVI-D100P: PAL Color, CCIR standards
Picture element	1/4 inch color CCD (Total picture elements: EVI-D100: Approx. 410,000 EVI-D100P: Approx. 470,000) (Effective picture elements: EVI-D100: Approx. 380,000 EVI-D100P: Approx. 440,000)
Lens	10× (Optical), 40× (Digital) f=3.1 to 31 mm, F1.8 to F2.9 Horizontal angle: 6.6 degrees to 65 degrees
Minimum object distance	WIDE end : 100 mm TELE end : 600 mm
Minimum illumination	3.5 lx (F1.8)/with 50 IRE
Illumination range	3.5 to 100,000 lx
Shutter speed	EVI-D100: 1/4 to 1/10,000 s (VISCA control) EVI-D100P: 1/3 to 1/10,000 s (VISCA control)
Horizontal resolution	NTSC : 470 TV (WIDE end) PAL : 460 TV (WIDE end)
Video S/N	50 dB
Pan/tilt action	Horizontal: ±100 degrees Maximum speed: 300 degrees/s, Vertical: ±25 degrees Maximum speed: 125 degrees/s (in 5/72 (0.07) degree increments)

Input/output terminals

Video output	RCA pin jack (1), 1V _{pp} , 75 ohm unbalanced Synchronization: negative
--------------	---

S video output	4 pin mini DIN (1)
Input/output control terminals	RS-232C (input: 1, output: 1), 8 pin mini DIN, 9600 bps Data: 8 bit Stop bit: 1
Power terminal	JEITA type4

General

Input voltage	DC 12 V (DC 10.8 to 13 V)
Current consumption	1.1 A (at 12 V DC)
Operating temperature	0 °C to 40 °C (32 °F to 104 °F)
Storage temperature	- 20 °C to 60 °C (- 4 °F to 140 °F)
Dimensions	Video camera: 113 × 120 × 132 mm (4 1/2 × 4 3/4 × 5 1/4 in.) (w/h/d) Remote Commander: 56 × 26 × 210 mm (2 1/4 × 1 1/16 × 8 3/8 in.) (w/h/d)
Mass	Video camera: 860 g (1 lb 14 oz.) Remote Commander: 109 g (3.8 oz.)
Installation angle	±15 degrees to a horizontal surface

Supplied accessories

AC power adaptor (1)
Power cord (1)
Remote Commander (1)
Velcro tape (3 sets)
Operating Instructions (1)

Design and specifications are subject to change without notice.

Dimensions

Front

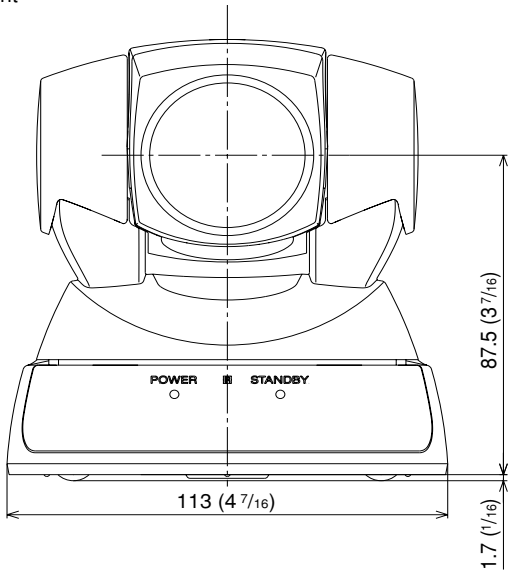

Right side

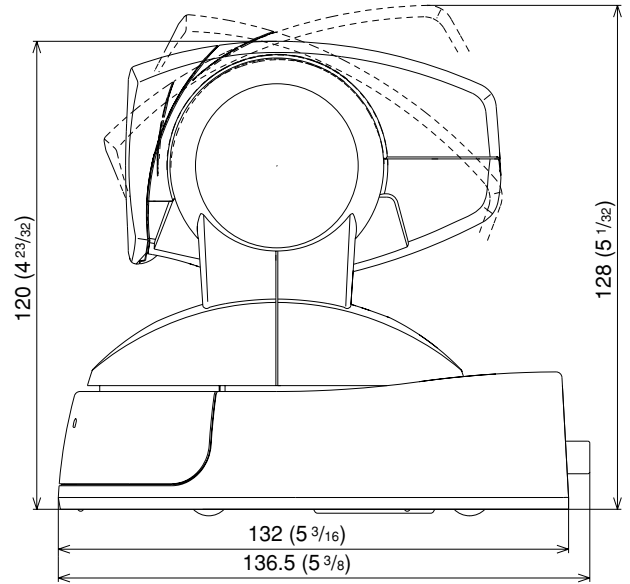

Top

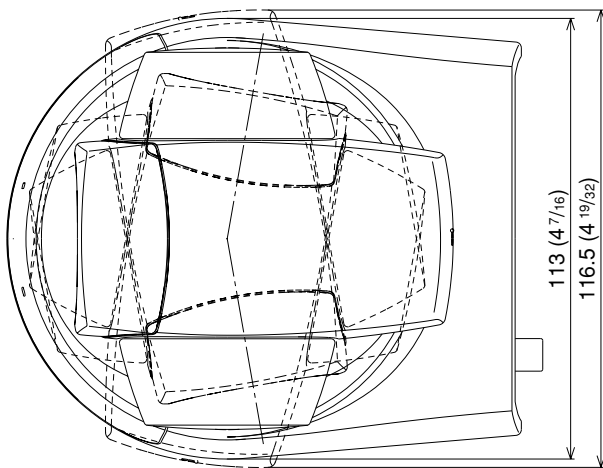

Bottom

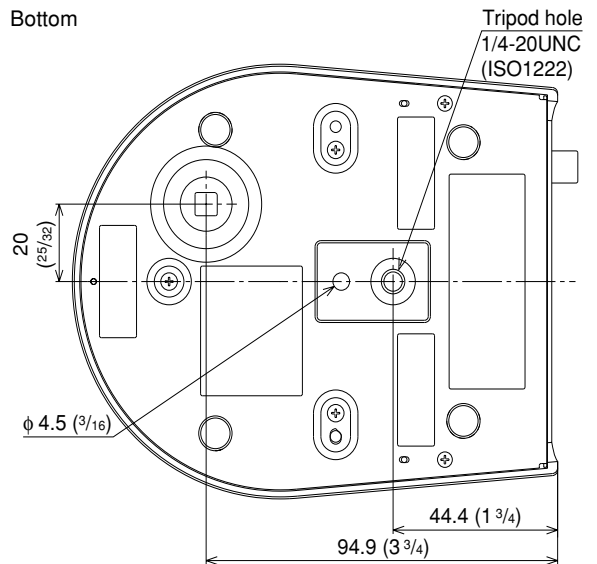

Unit: mm (inches)

Precautions

Software

Use of the demonstration software developed by Sony Corporation or use of the software with customer developed application software may damage hardware, the application program or the camera. Sony Corporation is not liable for any damages under these conditions.

Operation

Start the camera control software on your computer after you turn on the camera and the image is displayed.

Operation and storage locations

Do not shoot images that are extremely bright (e.g., light sources, the sun, etc.) for long periods of time. Do not use or store the camera in the following extreme conditions:

- Extremely hot or cold places (operating temperature 0 °C to +40 °C (32 °F to 104 °F))
- Close to generators of powerful electromagnetic radiation such as radio or TV transmitters
- Where it is subject to fluorescent light reflections
- Where it is subject to unstable (flickering, etc.) lighting conditions
- Where it is subject to strong vibration

Care of the unit

Remove dust or dirt on the surface of the lens with a blower (commercially available).

Other

Do not apply excessive voltage. (Use only the specified voltage.) Otherwise, you may get an electric shock or a fire may occur.

In case of abnormal operation, contact your authorized Sony dealer or the store where you purchased the product.