



VADDIO™ WIDESHOT™ WALLVIEW™ SR

Wide Angle HD Point of View Camera System with a 82.2° Horizontal Field of View Manual Lens and the Quick-Connect™ SR Interface

Model Number 999-6910-000 (North America)

Model Number 999-6910-001 (International)

Touchboards

205 Westwood Ave, Long Branch, NJ 07740
Phone: 866-94 BOARDS (26273) / (732)-222-1511
Fax: (732)-222-7088 | E-mail: sales@touchboards.com



Inside Front Cover - Blank



TABLE OF CONTENTS

- Overview 4
- Unpacking: 5
 - Front View with Feature Call-outs 5
 - Image: WideSHOT HD PTZ Camera 5
 - Setting the WideSHOT Lens 6
 - Image: WideSHOT Focus Knob Removal 6
 - Image: Adjusting the HD Varifocal Optical Zoom Lens 6
 - Rear Panel Connections with Feature Call-outs 7
 - Image: WideSHOT HD Camera 7
- Quick-Connect SR Interface 8
 - Image: Rear Panel with Feature Call-outs 8
- First Time Set-up: 8
 - Step By Step Installation Instructions: 9
- Framing the WideSHOT's Video Shot 10
 - Drawing: A Small Conference Room (10' wide x 12' long) with a WideSHOT HD camera 10
 - Drawing: A Bigger, Small Conference Room (12' wide x 16' long) with WideSHOT HD 10
 - Image: Basic Wiring Configuration 11
- IR SHOT Commander Remote Control 12
 - Image: Vaddio IR SHOT Commander Hand-held IR remote 12
- Compliance and CE Declaration of Conformity - WideSHOT 13
- Warranty Information 14
 - WideSHOT WallVIEW SR General Specifications: 15
- Appendix 1: Pin-outs for WideSHOT Camera 16
 - Table EZCamera Power & HD Video RJ-45 Connector Pin-outs 16
- Appendix 2: Pin-outs for Quick-Connect SR Interface 16
 - Table: DE-15 - YPbPr Pin-Out 16
- Appendix 3: Communication Specification 17
 - WideSHOT Command List 17
 - WideSHOT Inquiry List 18
- Appendix 4: WideSHOT OSD Menu Tree 19

OVERVIEW:

The Vaddio WideSHOT HD camera wide angle, manual lens camera produces amazing results for small and huddle room applications where the distance between the camera and the subject is limited. The WideSHOT camera was designed as a low cost, high value, manual pan/tilt camera with a super wide-angle lens that can be set to provide the best image possible in a small environment. To that end, the WideSHOT camera sports a lens with 82.2° wide horizontal field of view with a user adjustable iris, focus and varifocal zoom of approximately 3X (3.3mm to 10.5mm). With the 3X zoom capability, even the “big” small rooms can be covered too.

Like the ZoomSHOT™, the WideSHOT is a camera with a unique genealogy. Designed from the ground up, the WideSHOT camera uses the Vaddio EZCamera™ Cat-5 wiring standard for video, power and control. Using HSDS™ (high speed differential) video outputs over Cat-5 cable, the WideSHOT supplies a wide range of video resolutions that are selectable from the rear panel; from 480p/59.94-YPbPr up to and including 1080p/60. The HSDS processing allows delivery of the HD video signals up to 150' (45.72m).

Choose between three (3) IR frequencies for the Vaddio IR Shot Commander remote controller to allow multiple cameras to be locally IR controlled with a single remote. The WideSHOT also has an OSD (on screen display) for easy set-up and basic image control that's accessible with the IR remote. Two (2) camera configuration presets can be programmed and recalled via the remote or RS-232 and IR signal forwarding is also included.

WideSHOT is paired with the tried-and-true Quick-Connect SR Interface in this package which represents an exceptional value and a very low price. So relax, for the next small room design, try a WideSHOT Wide-angle HD Camera.



Image: WideSHOT HD Camera



Image: WideSHOT Rear Panel

Intended Use:

Before operating the device, please read the entire manual thoroughly. The system was designed, built and tested for use indoors with the power supply provided. The use of a power supply, other than the one provided, or outdoor operation has not been tested and could damage the device and/or create a potentially unsafe operating condition.

Important Safeguards:

Read and understand all instructions before using. Do not operate any device if it has been dropped or damaged. In this case, a Vaddio technician must examine the product before operating. To reduce the risk of electric shock, do not immerse in water or other liquids and avoid extremely humid conditions.



Use only the power supply provided with the system. Use of any unauthorized power supply will void any and all warranties.



Please do not use “pass-thru” type RJ-45 connectors. These pass-thru type connectors do not work well for professional installations and can be the cause of intermittent connections which can result in the RS-232 control line failing and locking up, and/or compromising the HSDS (high speed differential) signals. For best results please use standard RJ-45 connectors and test all cables for proper pin-outs prior to use and connection to Vaddio product.

Save These Instructions:

The information contained in this manual will help you install and operate your product. If these instructions are misplaced, Vaddio keeps copies of Specifications, Installation and User Guides and most pertinent product drawings for the Vaddio product line on the Vaddio website. These documents can be downloaded from www.vaddio.com free of charge.

UNPACKING:

Carefully remove the product and all of the included parts from the packaging. Identify the following parts for each camera:

WideSHOT WallVIEW SR Camera System (North America):

Part Number: 999-6910-000

- One (1) WideSHOT HD Wide-Angle Camera (998-6910-000)
- One (1) Vaddio IR SHOT Commander Remote
- One (1) Quick-Connect SR Interface
- One (1) 3-Position Phoenix-type Connector for IR Forwarding
- One (1) 24 VDC, 2.0 A Power Supply with Power Cord for North America
- One (1) Thin Profile Wall Mount with Mounting Hardware
- One (1) EZCamera™ Control Adapter (RJ-45-F to DB-9-F)
- Documentation



WideSHOT WallVIEW SR Camera System (International):

Part Number: 999-6910-001

- One (1) WideSHOT HD Camera (998-6910-000)
- One (1) Vaddio IR SHOT Commander Remote
- One (1) Quick-Connect SR Interface
- One (1) 3-Position Phoenix-type Connector for IR Forwarding
- One (1) 24 VDC, 2.0 A Power Supply
- One (1) Euro Power Cable
- One (1) UK Power Cable
- One (1) Thin Profile Wall Mount with Mounting Hardware
- One (1) EZCamera™ Control Adapter (RJ-45-F to DB-9-F)
- Documentation



Front View with Feature Call-outs

Image: WideSHOT HD PTZ Camera



- 1) Lens:** 3.3mm to 10.5mm Varifocal HD Zoom Lens (16:9), 82.2° wide end , 27.4° tele end (approx. 3X zoom)
- 2) IR Sensor and Power/Tally LED:** The IR sensor for the IR SHOT Commander remote is located here. Below it is a light pipe where a blue LED power and a red LED tally reside. Both light up to produce purple.
- 3) Focus Knob Retention Screw:** Remove screw and knob to manually set zoom and iris (see next page).
- 4) The Yoke:** For manual pan and tilt. Tilt range is $\pm 30^\circ$ and Pan is limited to the service loop of the cabling.
- 5) Logo:** Really Cool Logo Badge (RCLB). The RCLB is affixed to the base in a recessed ovoid area.
- 6) The Aluminum Base and Steel Cylindrical Body:** Please don't drop it on your foot, it's fairly substantial.

Setting the WideSHOT Lens

Image: WideSHOT Focus Knob Removal

You may ask, “Why would anyone want to remove the focus knob?” The answer is directly correlated with the quality of this wide-angle HD lens. It is not a plastic “webcam”, but instead it is an exceptional quality glass lens, rated up to 3-megapixel with a 3.3mm to 10.5mm precision varifocal optical zoom lens with manual iris and manual focus controls.

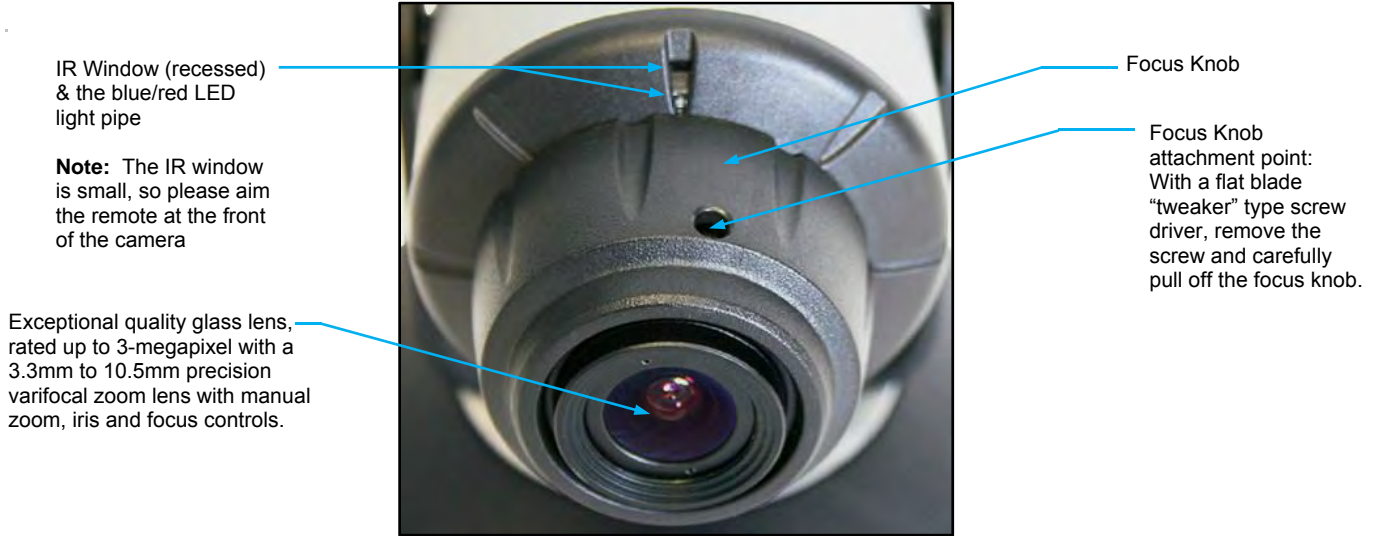

Image: Adjusting the HD Varifocal Optical Zoom Lens

After removing the focus knob screw and carefully sliding off the “snug” focus knob, the lens controls are exposed and available for adjustment. The controls are as follows:

- 1) **The Optical Zoom Control:** By carefully untightening the knurled screw a half turn on the innermost ring, adjust the ring to either the wide (W) or tele (T) direction. The focus ring, now without knurled adjustment screw (screw taken out to remove the focus knob) will need to be adjusted as the zoom is changed. Experiment with the zoom range to fit the application. A full 82.2° may be too wide in some cases and tailoring the zoom to 65° to 70° may fit the room better. After setting the control, tighten the knurled screw.
- 2) **The Manual Iris Control:** After setting the zoom range and focusing on the subject’s at the distance that the camera will be used, the iris can be adjusted to limit the amount of light that the image sensor receives, which in turn gives an increased depth of field for focusing on the people in front of the camera. The “O” stands for open and the “C” stands for closed. Experiment with the iris to achieve the best results for the application. After setting the control, tighten the knurled screw.
- 3) **The Focus Control:** The outermost ring is the focus control and can be adjusted to the near (N) or far (F) side. Set the focus ring to the approximate position and reattach the focus knob with the knurled screw when finished.



Rear Panel Connections with Feature Call-outs

Image: WideSHOT HD Camera

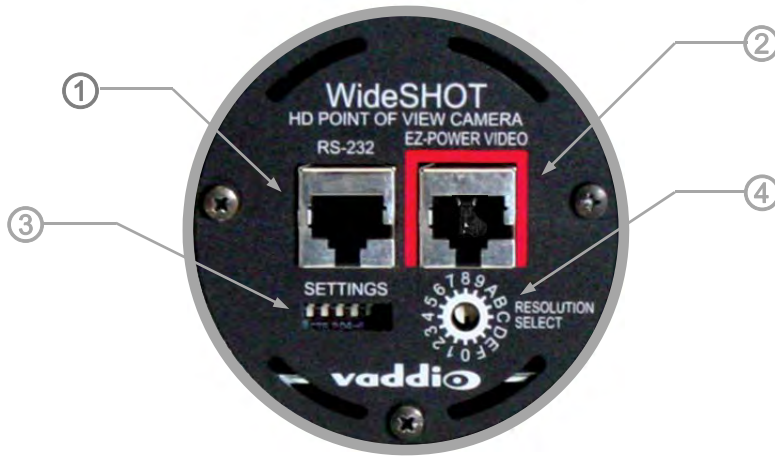

1) RS-232 & IR Out: The RS-232 accepts modified VISCA protocol for camera control, as well as transmits IR signaling received by the front IR receiver, which can be transmitted to third party devices

2) EZ Power/Video Port:

This RJ-45 connector is only used with the Quick-Connect SR, Quick-Connect DVI-D/HDMI SR Interface, Quick-Connect USB and USB Mini Interfaces to supply power and return HSDS (differential) video from the camera over Cat-5 cable up to distance of 150' (45.72m).

3) Dip Switch Settings:

Settings for IR remote frequency, IR receiver on/off, image flip, test bars and defaults can be configured on these switches. See the Switch Settings page for additional information. The dip switch settings are as follows:

Dip Switch	Function
1	Up = IR1, Down = IR2
2	Up = IR 1 or 2, Down = IR3
3	Up=IR ON, Down = IR OFF
4	Up = Normal Image, Down = Image Flip
5	Test Bars
6	Update Position - Leave UP unless updating firmware
All Down	Reset to Defaults - with power cycle



4) HD Video Select:

A rotary switch allows the user to choose the video output resolution for the camera. After setting or changing the resolution, reboot the camera to ensure proper operation. If an unassigned rotary selection position is chosen (3, 9, A, B, C or D), the camera will output a medium grey video privacy mask. The HD Video Select Rotary Switch Settings are as follows:

Rotary	Resolutions	Rotary	Resolutions
0	720p/59.94	8	576p/59.94
1	1080i/59.94	9	--
2	1080p/59.94	A	--
3	--	B	--
4	720p/50	C	--
5	1080i/50	D	--
6	1080p/50	E	1080p/29.97
7	480p/59.94	F	1080p/25



Point the notch in the switch stem to assign the rotary position (the camera is on Position 1 1080i/59.94).

Important Notes:

- 1) For IP or USB 2.0 Streaming, use position "0" (720p/59.94) for best results
- 2) Set the rotary switch to an unassigned position and a medium grey privacy mask is displayed.

QUICK-CONNECT SR INTERFACE

Image: Rear Panel with Feature Call-outs

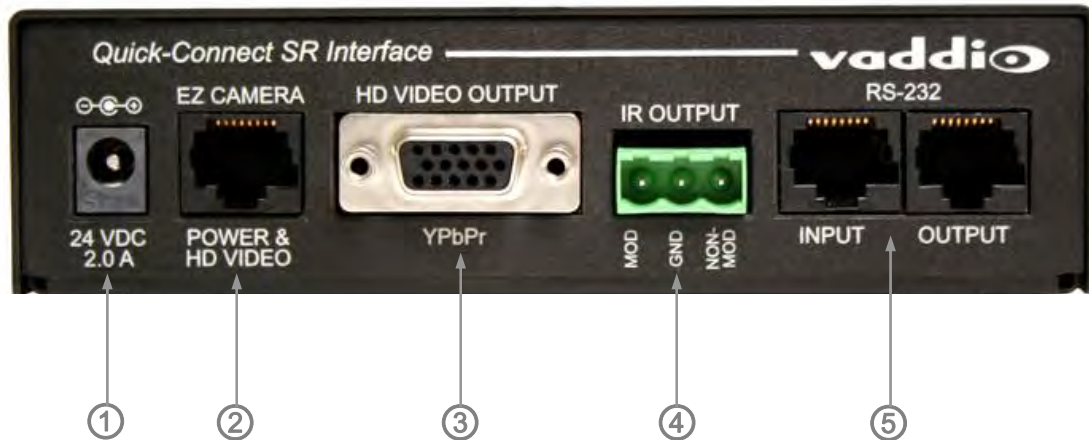

1) Power Input:

5.5mm OD x 2.5mm ID coaxial connector for the provided PowerRite 24 VDC, 2.0 Amp power supply.

2) EZCamera Power & HD Video:

A single Cat-5 connection between the EZCAMERA POWER & HD VIDEO RJ-45 connector and the camera's EZ Power HD Video Port on the HD-19 camera extends power and video. Power is fed to the camera and HSDS video is returned from the camera on the same Cat-5.

3) HD Video Output:

DE-15 connector outputs the YPbPr analog component HD video, which was extended from the camera over Cat-5 cable. SD video resolutions (Y/C and CVBS formats) are not supported by the Quick-Connect SR Interface, however analog component SD video is supported.

4) IR Output:

With the IR pass-thru turned ON (see camera dip switch settings), IR from third-party IR remote controls can be sent through the WideSHOT camera to third-party equipment, such as hardware videoconferencing codecs. IR can be used as either modulated (through the air) or non-modulated (wired) signals).

5) RS-232 Input & Output Jacks:

These RJ-45 connectors allow an external controller to route through the Quick-Connect SR for ease of cabling.

FIRST TIME SET-UP

The WideSHOT was designed to be very easy to use and operate. There is documentation at the back of this manual for pin-outs of the connectors on the Quick-Connect SR Interface and WideSHOT HD camera.

Before Installing:

- Choose the camera mounting location by paying close attention to camera viewing angles, lighting conditions, possible line of site obstructions, and checking for in-wall obstructions where the camera is to be mounted. Always pick a mounting location that will optimize the performance of the camera.
- The Thin Profile Wall Mount for the WideSHOT can be mounted directly to a 1-gang wall box or can be mounted using only dry wall anchors.
- For Power/Video and RS-232 signals, use standard Cat-5 cable (568B termination and real RJ-45 connectors) from the EZ-POWER VIDEO and RS-232 ports on the back of the WideSHOT camera to the Quick-Connect SR Interface. The EZ-POWER VIDEO jack on the camera is highlighted **red** as a reminder that there is 24 VDC power on that Cat-5 cable.

Step By Step Installation Instructions:

Step 1: After determining the optimum location of the camera, route, mark and test the two Cat-5 cables from the camera to the Quick-Connect SR Interface located at the head-end. The two Cat-5 cables should feed-through the hole located on the rear flange of the supplied Thin Profile Wall Mount. The bracket can be mounted to a 1-gang wall box. If the mount is to be mounted on a 1-gang wall box, use the screws supplied with the wall box cover plate to attach the Thin Profile Wall Mount. If mounting to the drywall with wall anchors, use two quality wall anchors (provided). Level the mount and tighten the mounting screws.



Step 2:

Using the HD VIDEO SELECT rotary switch and CAMERA SETTINGS dip switches on the back of the camera, set up the camera's output resolution and functional preferences. There are tables on previous pages that identify the choices...maybe keep these tables handy for future use...or you can easily look them up on the Vaddio website (vaddio.com) when needed.

Switches to set on the camera:

- Set the desired HD Resolution with the rotary selection switch.
- Set the IR frequency of the camera (if it is to respond to the IR remote control).
- Set the image orientation (normal or flipped).

On the WideSHOT camera, the remote will basically navigate through the OSD menus since the camera's zoom, iris and focus are manual.

Step 3: Follow the sample wiring diagram for connecting the Cat-5 cables to the WideSHOT and Quick-Connect SR Interface (yep, on the next page, but read and understand the rest of these instructions especially the next note).



NOTE: Check all Cat-5e cables for continuity in advance of the final connection. Label the Cat-5e cables. Plugging the EZ POWER HD VIDEO cable into the wrong RJ-45 may cause damage to the camera system and void the warranty. For premise cabling, please use real RJ-45 connectors and crimpers. Please don't use the pull through or EZ type of RJ-45 connectors.

Step 4: Place the camera onto the camera mount and use the provided ¼"-20 screws to secure the camera to the mount. To dress the cabling, push the extra cable back into the wall opening.

Step 5: Connect the Vaddio 24 VDC, 2.0 Amp power supply to a power outlet and to the Quick Connect SR Interface. Power will travel down the Power/Video Cat. 5 cable to the camera. The camera will boot up and in a few seconds, HSDS (differential) video will travel back down the Cat-5 cable and be ready to accept control information from the IR remote control or other camera controller.



To insure proper continuity of control and operation of the cameras, the RS-232 controller (control system or joystick) should be powered on after the camera.

Touchboards

205 Westwood Ave, Long Branch, NJ 07740
 Phone: 866-94 BOARDS (26273) / (732)-222-1511
 Fax: (732)-222-7088 | E-mail: sales@touchboards.com

FRAMING THE WIDESHOT'S VIDEO SHOT

When framing the shot with a WideSHOT Camera, consider and review the following elements:

- The area should be well lit and without reflective surfaces. For wall surfaces, use a flat paint or wall coverings to minimize audio reflections. Use neutral colors, for example; pale grey, pale blue or beige that are easy for any camera to process.
- Avoid white and black or a stark contrast color pallet, avoid placing a big old white board in the background, and avoid complex décor in view of the camera (modern art). Avoid glass, chrome, mirrors, and glass on table tops to minimize the lighting and audio reflections.
- Always avoid having a window in the camera shot as sunlight can be disruptive of camera performance. Window treatments are a must for rooms with windows to achieve evenly lit space without direct sunlight.
- Never position the camera so that any ceiling lights are in the video frame. No one sits anywhere near the ceiling and direct lighting in the frame can be problematic for the automatic functions of the camera.

The bottom line is simple, give the camera a chance to work well in the room and excellent video is the result.

There are many room set up primers available on today's internet for reference.

Drawing: A Small Conference Room (10' wide x 12' long) with a WideSHOT HD camera

WideSHOT set at the wide end (82.2°).

The WideSHOT HD camera set to the full wide end of 82.2° is an excellent choice for small (huddle) conferencing rooms that range from 8' (2.44m) to 12' (3.66m) in width x depth.

In this example, the table front is 4' (1.22m) away from the camera and the WideSHOT can easily capture all of the meeting participants from this distance

The WideSHOT can be manually zoomed into a tighter shot for a conference room with fewer participants as well.

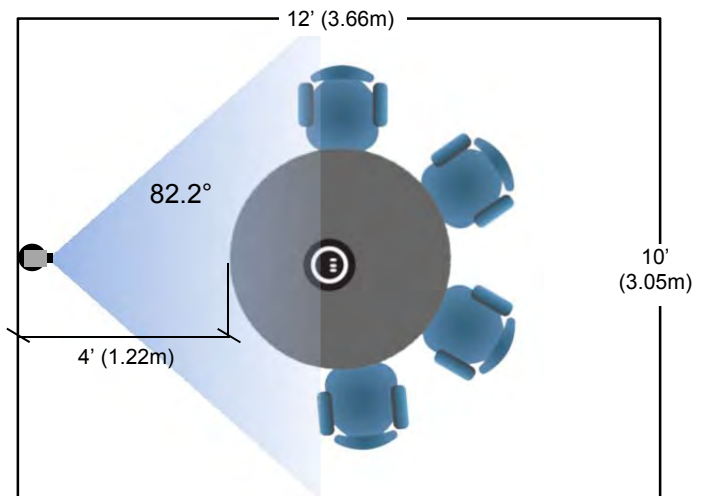

Drawing: A Bigger, Small Conference Room (12' wide x 16' long) with WideSHOT HD

WideSHOT set at the wide end 82.2° - Lt. Blue

WideSHOT reset to approx. 58° - Red

The WideSHOT HD camera set to the full wide end of 82.2°, in this example, is too wide for this room and will not render any real detail such as facial expressions and other mannerisms of the meeting participants.

The WideSHOT can be zoomed into a tighter shot (58° or tighter - rose colored viewing angle) allowing all the subjects in this room be seen on camera while still providing the details needed for effective visual communications.

Please see the **Setting the WideSHOT Lens** section on page 6.

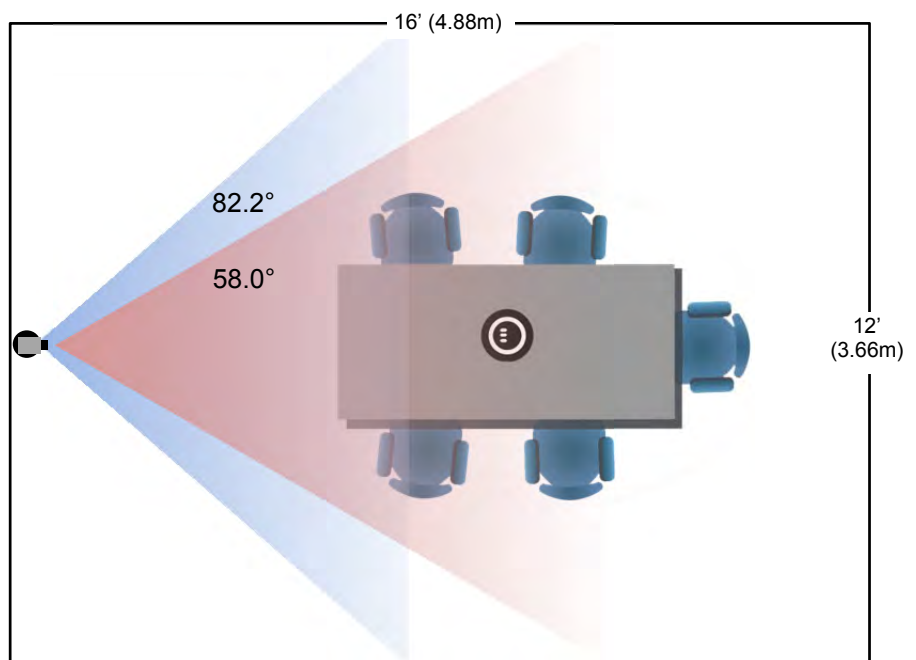

Image: Basic Wiring Configuration



IR SHOT COMMANDER REMOTE CONTROL

Spatially Efficient IR Remote Controller for ZoomSHOT™ and WideSHOT™ Camera Systems

The Vaddio IR SHOT Commander was designed to work with the Vaddio ZoomSHOT and WideSHOT camera systems and is compatible with the PowerVIEW™, ClearVIEW™ cameras and the WallVIEW™ camera system packages. The Vaddio IR SHOT Commander is compatible with the following Vaddio camera packages:

- ZoomSHOT and WideSHOT Camera Systems (shipped with these products)
- Vaddio ClearVIEW HD-18, HD-19, HD-20, PowerVIEW HD-22, HD-30 and REVEAL™ HD-18 (limited functionality)

The Vaddio IR Shot Commander is also compatible with the Sony® EVI series and the BRC series PTZ cameras.

Basic Instructions:

- Pick the IR Frequency to match the dip switch setting of the camera. Operate the remote (but not too fast).
- **Note:** The Pan/Tilt/Zoom controls are not used with the manual lens of the WideSHOT HD Camera.

Image: Vaddio IR SHOT Commander Hand-held IR remote

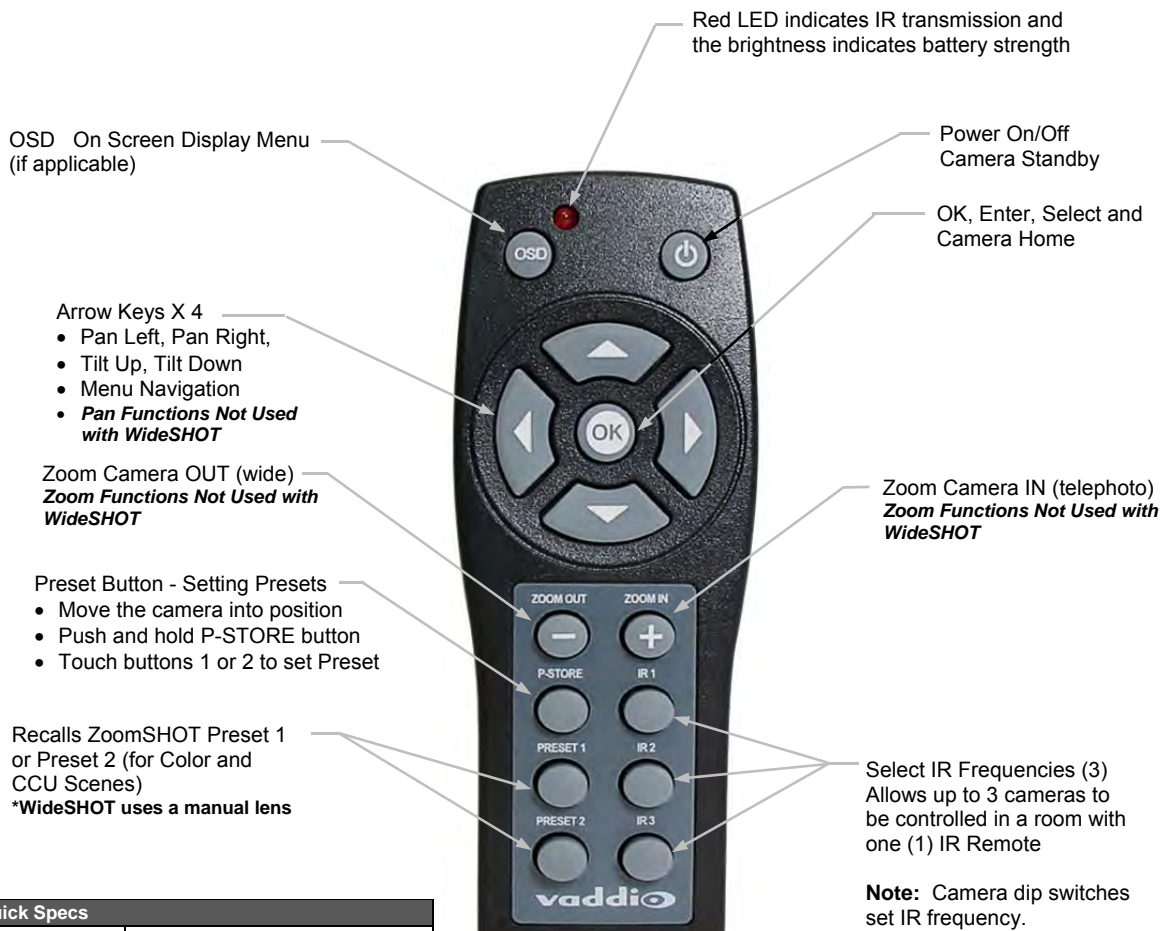

Quick Specs	
IR Range	20' to 30' (6m to 9m)
Batteries	2 x AAA (Batteries not shipped with 998-2101-001)
Keys (buttons)	15 Silicone Rubber Keys
Dimensions L x W x H	4.53" (115mm) x 1.57" (40mm) x 1.1" (28mm)
LED Indicator	Red LED Illuminates when transmitting IR, Brightness indicates battery strength
Compatible Cameras	Ships with ZoomSHOT and WideSHOT. Compatible with all Vaddio ClearVIEW, PowerVIEW cameras (limited function set) and most Sony BRC & EVI cameras, but with limited functionality

COMPLIANCE AND CE DECLARATION OF CONFORMITY - WIDESHOT

Compliance testing was performed to the following regulations:

- | | |
|---|---------|
| • FCC Part 15 (15.107, 15.109), Subpart B | Class A |
| • ICES-003, Issue 4: 2004 | Class A |
| • EN 55022 A: 2006 + A1: 2007 | Class A |
| • KN22 2008 (CISPR 22: 2006) | Class A |
| • KN24 2008 (CISPR 24: 1997 + A1: 2000 + A2: 2002) | Class A |
| • EMC Directive 2004/108/EC | Class A |
| • EN 55024: A2: 2003 | Class A |



FCC Part 15 Compliance

This equipment has been tested and found to comply with the limits for a Class A digital device, pursuant to Part 15, Subpart B, of the FCC Rules. These limits are designed to provide reasonable protection against harmful interference when the equipment is operated in a commercial environment. This equipment generates, uses, and can radiate radio frequency energy and, if not installed and used in accordance with the instruction manual, may cause harmful interference to radio communications. Operation of this equipment in a residential area is likely to cause harmful interference in which case the user will be required to correct the interference at his/her own expense.

Operation is subject to the following two conditions: (1) This device may not cause interference, and (2) This device must accept any interference including interference that may cause undesired operation of the device. Changes or modifications not expressly approved by Vaddio can affect emission compliance and could void the user's authority to operate this equipment.



ICES-003 Compliance

This digital apparatus does not exceed the Class A limits for radio noise emissions from digital apparatus set out in the Radio Interference Regulations of the Canadian Department of Communications.

Le présent appareil numérique n'émet pas de bruits radioélectriques dépassant les limites applicables aux appareils numériques de la classe A prescrites dans le Règlement sur le brouillage radioélectrique édicté par le ministère des Communications du Canada.



European Compliance

This product has been evaluated for Electromagnetic Compatibility under the EMC Directive for Emissions and Immunity and meets the requirements for a Class A digital device. In a domestic environment this product may cause radio interference in which case the user may be required to take adequate measures.

Standard(s) To Which Conformity Is Declared:

EMC Directive 2004/108/EC

EN 55022 A: 2006 + A1: 2007(CISPR 22:2005/A1:2005)

EN 55024: A2: 2003

- EN 61000-4-2: 1995 + Amendments A1: 1998 + A2: 2001
- EN 61000-4-3: 2006 + A1: 2008
- EN 61000-4-4: 2004 + Corrigendum 2006
- EN 61000-4-5: 2006
- EN 61000-4-6: 2009
- EN 61000-4-8: 2010
- EN 61000-4-11: 2004

KN24 2008 (CISPR 24: 1997 + A1: 2000 + A2: 2002)

- EN 61000-4-2
- EN 61000-4-3
- EN 61000-4-4
- EN 61000-4-5
- EN 61000-4-6
- EN 61000-4-8
- EN 61000-4-11

IEC 60950-1:2005 (2nd Edition); Am 1:2009

EN 60950-1:2006+A11:2009+A1:2010+A12:2011

Class A

Immunity

Electrostatic Discharge

Radiated Immunity

Electrical Fast Transients

Surge Immunity

Conducted Immunity

Power Frequency Magnetic Field

Voltage Dips, Interrupts and Fluctuations

IT Immunity Characteristics

Electrostatic Discharge

Radiated Immunity

Electrical Fast Transients

Surge Immunity

Conducted Immunity

Power Frequency Magnetic Field

Voltage Dips, Interrupts and Fluctuations

Safety

Safety

WARRANTY INFORMATION

(See Vaddio Warranty, Service and Return Policies posted on vaddio.com for complete details):

Hardware* Warranty: Two (2) year limited warranty on all parts and labor for Vaddio manufactured products. Vaddio warrants its manufactured products against defects in materials and workmanship for a period of two years from the day of purchase, to the original purchaser, if Vaddio receives notice of such defects during the warranty. Vaddio, at its option, will repair or replace products that prove to be defective. Vaddio manufactures its hardware products from parts and components that are new or equivalent to new in accordance with industry standard practices.

Exclusions: The above warranty shall not apply to defects resulting from improper or inadequate maintenance by the customer, customers applied software or interfacing, unauthorized modifications or misuse, mishandling, operation outside the normal environmental specifications for the product, use of the incorrect power supply, modified power supply or improper site operation and maintenance. OEM products and products manufactured by other companies are excluded and are covered by the manufacturer's warranty.

Vaddio Customer Service: Vaddio will test, repair, or replace the product or products without charge if the unit is under warranty. If the product is out of warranty, Vaddio will test then repair the product or products. The cost of parts and labor charge will be estimated by a technician and confirmed by the customer prior to repair. All components must be returned for testing as a complete unit. Vaddio will not accept responsibility for shipment after it has left the premises.

Vaddio Technical Support: Vaddio technicians will determine and discuss with the customer the criteria for repair costs and/or replacement. Vaddio Technical Support can be contacted through one of the following resources: e-mail support at support@vaddio.com or online at vaddio.com.

Return Material Authorization (RMA) Number: Before returning a product for repair or replacement request an RMA from Vaddio's technical support. Provide the technician with a return phone number, e-mail address, shipping address, product serial numbers and original purchase order number. Describe the reason for repairs or returns as well as the date of purchase. See the General RMA Terms and Procedures section for more information. RMA's are valid for 30 days and will be issued to Vaddio dealers only. End users must return products through Vaddio dealers. Include the assigned RMA number in all correspondence with Vaddio. Write the assigned RMA number clearly on the shipping label of the box when returning the product. All products returned for credit are subject to a restocking charge without exception.

Voided Warranty: The warranty does not apply if the original serial number has been removed or if the product has been disassembled or damaged through misuse, accident, modifications, use of incorrect power supply, use of a modified power supply or unauthorized repair.

Shipping and Handling: Vaddio will not pay for inbound shipping transportation or insurance charges or accept any responsibility for laws and ordinances from inbound transit. Vaddio will pay for outbound shipping, transportation, and insurance charges for all items under warranty but will not assume responsibility for loss and/or damage by the outbound freight carrier. If the return shipment appears damaged, retain the original boxes and packing material for inspection by the carrier. *Contact your carrier immediately.*

Products not under Warranty: Payment arrangements are required before outbound shipment for all out of warranty products.

Other General Information:

Care and Cleaning

Do not attempt to take this product apart at any time. There are no user-serviceable components inside.

- Do not spill liquids in the product
- Keep this device away from food and liquid
- For smears or smudges on the product, wipe with a clean, soft cloth
- Use a lens cleaner on the lens - not a hanky
- Do not use any abrasive chemicals.

Operating and Storage Conditions:

Do not store or operate the device under the following conditions:

- Temperatures above 40°C (104°F) or temperatures below 0°C (32°F)
- High humidity, condensing or wet environments
- In inclement weather
- In swimming pools or under waterfalls
- Dry environments with an excess of static discharge
- In orbit (vacuum issue)
- Under severe vibration

WideSHOT WallVIEW SR General Specifications:

WideSHOT Camera System	
Part Numbers	WideSHOT WallVIEW 999-6910-000 (North America) WideSHOT WallVIEW 999-6910-001 (International)
Image Sensor	1/3-Type Progressive Scan CMOS Sensor with 1.3 Megapixels
Video Output Resolutions	HD: 1080/59.94/50/30/25, 1080i/59.94/50, 720p/59.94/50 SD: 480p/59.94 & 576p/50
Lens/ Focal Length	Approx. 3X Optical Zoom, 3.3mm to 10.0mm manual focus
Horizontal Viewing Angle	82.2° Wide End to 3.2° Tele End, 27.4° Tele End - 16:9 Format
Video S/N Ratio	>50 dB
Minimum Illumination	0.2 LUX (1/30 Shutter Speed) Color
Serial Control Protocol	RS-232 (Modified VISCA)
Manual Pan/Tilt Range	Pan: Limited to service loop of cabling, yoke and base are mechanical only Tilt: ± 30° Invertible for Ceiling Mount
Preset Positions	Manual
Tally Light	Red LED available through RS-232 Control
Camera Connectors	Two (2) RJ-45 Jacks: <ul style="list-style-type: none"> EZ-Power VIDEO RJ-45 Jack for use with Quick-Connect - Supplies power to the camera and returns differential HD video from the camera RS-232 RJ-45 Jack (RS-232 Communication and IR Out (with Quick-Connect -SR Interfaces)
HD Video Select	16-Position Rotary Switch: Used to set HD Video Resolution Output
Camera Settings	6-Position Dip Switch: For IR Freq., Baud Rate 9600, Image Flip & Test Bars 16-Position Rotary Switch for Output Resolution Settings
Thin Profile Wall Mount	535-2000-237 (Provided with WideSHOT WallVIEW Systems) Black powder coating, Sized to fit on 1-gang wall box or drywall mounting
User Controls	IR SHOT Commander with OSD for set-up and RS-232
Materials & Weight	Aluminum & Steel, Weight = 2.45643 lbs. (1.1142179kg)
Dimensions:	Tube: 3.5" (88.9mm) Diameter x 5.125" (130.175mm) Long (including front bezel and focus knob) Base: 5.5" (139.7mm) Diameter Overall Height: 5.5" (139.7mm) Tall
Quick-Connect SR Interface	
Connectors	<ul style="list-style-type: none"> Power Connector: 5.5mm OD, 2.5mm ID coaxial connector Power/Video RJ-45: Supplies power to, and differential HD video from the camera Video Output: DE-15 connector for HD Analog Component (YPbPr) video only (No SD Support) IR Output: Transmits modulated or non-modulated IR signals received from the camera's IR receiver RS-232 IN RJ-45: Accepts RS-232 from ProductionVIEW or other external control systems RS-232 OUT RJ-45: Sends RS-232 from Quick-Connect SR to the camera
Power Supply	24 VDC, 2.0 Amp
Dimensions (H x W x D)	1/3 Rack Size - 1.6" (40.64mm) H x 5.5" (139.7mm) W x 3.25" (82.5500000000001mm) D
Weight	0.45 lbs. (0.20411657 kg)
Accessory	Rack Mount Adapter: 998-6000-002 - Holds three (3) Quick-Connect SR Interfaces

Planet in Front Page Header: Venus (filtered for detail)

APPENDIX 1: PIN-OUTS FOR WIDESHOT CAMERA
Table EZCamera Power & HD Video RJ-45 Connector Pin-outs

WideSHOT EZPOWER HD VIDEO PORT

Pin	YPbPr
1	Power+
2	Power-
3	Y+
4	PB+
5	PB -
6	Y -
7	PR+
8	PR-

**EZ POWER
HD VIDEO**

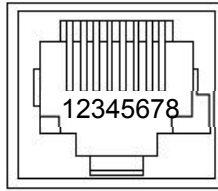

Important Note: The EZ POWER HD VIDEO RJ-45 Connector is for use with the **Quick-Connect SR, Quick-Connect DVI/HDMI SR, Quick-Connect USB and USB Mini Interfaces ONLY** (568B Wiring Standard). The video signals are differential (HSDS™) and can only be received by the interfaces above.

WideSHOT Camera RS-232 Port

Pin #	Function
Pin - 1	N/A
Pin - 2	N/A
Pin - 3	N/A
Pin - 4	IR Output (Diff Signal to Quick-Connect SR Only)
Pin - 5	IR Ground (Diff Signal to Quick-Connect SR Only)
Pin - 6	Digital GND
Pin - 7	RXD (from TXD of control source)
Pin - 8	TXD (to RXD of control source)

RS-232

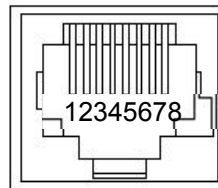

APPENDIX 2: PIN-OUTS FOR QUICK-CONNECT SR INTERFACE
Table: DE-15 - YPbPr Pin-Out

Pin	YPbPr
1	Pr
2	Y
3	Pb
4	-
5	-
6	Pr GND
7	Y GND
8	Pb GND
9	-
10	GND
11	-
12	-
13	-
14	-
15	-

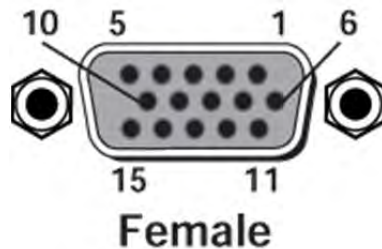

APPENDIX 3: COMMUNICATION SPECIFICATION

Communication Speed: 9600 bps (default)
 Start bit: 1
 Stop bit: 1
 Data bits: 8
 Parity: None
 No Flow control

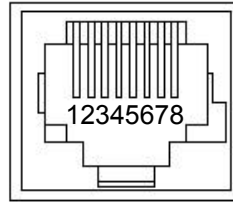

Pin #	RJ-45 RS-232 and IR Out Pins
1)	Unused
2)	Unused
3)	Unused
4)	IR Output (Diff Signal to Quick-Connect SR)
5)	IR Ground (Diff Signal to Quick-Connect SR)
6)	GND (GND of IR Short Range - Pin 3)
7)	RXD (from TXD of control source)
8)	TXD (to RXD of control source)

NOTE: The Vaddio WideSHOT Control Protocol is similar, but not identical to the Sony® VISCA™ command set in order to be compatible with several popular control devices. Not all VISCA commands are supported and there are many WideSHOT specific commands in the following Command and Inquiry Lists.

WideSHOT Command List

Command Set	Command	Command Packet	Comments
Address Set	Broadcast	88 30 01 FF	Address Set (Daisy chain)
IF Clear	Broadcast	88 01 00 01 FF	IF Clear
Command Cancel		8x 2p FF	p:socket number(1,2)
CAM_Power	On Off(Standby)	8x 01 04 00 02 FF 8x 01 04 00 03 FF	Power On/Off
CAM_WB	Auto Manual	8x 01 04 35 00 FF 8x 01 04 35 05 FF	Normal Auto Manual White Balance
CAM_RGain	Reset Up Down Direct	8x 01 04 03 00 FF 8x 01 04 03 02 FF 8x 01 04 03 03 FF 8x 01 04 43 00 0p 0q 0r FF	pqr: Red (0x0-0x010) Default 8
CAM_BGain	Reset Up Down Direct	8x 01 04 04 00 FF 8x 01 04 04 02 FF 8x 01 04 04 03 FF 8x 01 04 44 00 0p 0q 0r FF	pqr: Blue (0x0-0x010) Default 8
CAM_AE	Full Auto Manual	8x 01 04 39 00 FF 8x 01 04 39 03 FF	Auto Exposure Mode Manual Control Mode
CAM_Aperture	Reset Up Down Direct	8x 01 04 02 00 FF 8x 01 04 02 02 FF 8x 01 04 02 03 FF 8x 01 04 42 00 0p 0q 0r FF	pqr: Sharpness (0x0-0x010) Default 8
CAM_Bright	Reset Up Down Direct	8x 01 04 0D 00 FF 8x 01 04 0D 02 FF 8x 01 04 0D 03 FF 8x 01 04 4D 00 00 0p 0q FF	pqr: Bright (0x0-0x0010) Default 8
CAM_IDWrite		8x 01 04 22 0p 0q 0r 0s FF	pqr: 0x0000 – 0xFFFF
Tally	On Off	8x 01 7E 01 0A 00 02 FF 8x 01 7E 01 0A 00 03 FF	
BLK.Enhance	Pedestal	8x 01 7E 53 00 0p 0q 0r FF	pqr: Contrast (0x0-0x010) Default 8
CRM.Enhance	Chroma	8x 01 7E 55 00 0p 0q 0r FF	pqr: Saturation (0x0-0x010) Default 8
DNR.Enhance	Noise Reduction	8x 01 7E 58 00 0p 0q 0r FF	pqr: Noise reduction (0x0- 0x010) Default 0
AGC.Enhance	AGC Mode	8x 01 7E 59 00 FF 8x 01 7E 59 01 FF 8x 01 7E 59 02 FF	Low Auto Default High
CAM_Shutter	Reset Up Down Direct	8x 01 04 0A 00 FF 8x 01 04 0A 02 FF 8x 01 04 0A 03 FF 8x 01 04 4A 00 00 0p FF	p: Shutter Speed (0-8) Default 8

WideSHOT Inquiry List

Inquiry Command	Command	Response Packet	Comments
CAM_PowerInq	8x 09 04 00 FF	y0 50 02 FF y0 50 03 FF	On Off(Standby)
CAM_WBModelInq	81 09 04 35 FF	y0 50 00 FF y0 50 05 FF	Auto Manual
CAM_AEModelInq	8x 09 04 39 FF	y0 50 00 FF y0 50 03 FF	Auto Exposure Mode Manual Control Mode
CAM_IDInq	8x 09 04 22 FF	y0 50 0p 0q 0r 0s FF	pqrs:0x0000 – 0xFFFF
CAM_ApertureInq	8x 09 04 42 FF	y0 50 00 0p 0q 0r FF	pqr: Sharpness (0x00-0x010)
CAM_RGain	8x 09 04 43 FF	y0 50 00 0p 0q 0r FF	pqr: Red (0x00-0x010)
CAM_BGain	8x 09 04 44 FF	y0 50 00 0p 0q 0r FF	pqr: Blue (0x00-0x010)
CAM_Bright	8x 09 04 4D FF	y0 50 00 0p 0q 0r FF	pqr: Bright (0x00-0x010)
CAM_ShutterPosInq	8x 09 04 4A FF	y0 50 00 00 00 0p FF	p: Shutter Speed (0-8)
TallyInq	8x 09 7E 01 0A FF	y0 50 02 FF y0 50 03 FF	On Off
BLK.Enhance	8x 09 7E 53 FF	y0 50 00 0p 0q 0r FF	pqr: Contrast (0x00-0x010)
CRM.Enhance	8x 09 7E 55 FF	y0 50 00 0p 0q 0r FF	pqr: Saturation (0x00-0x010)
DNR.Enhance	8x 09 7E 58 FF	y0 50 00 0p 0q 0r FF	pqr: Noise reduction (0x00- 0x010)
AGC.Enhance	8x 09 7E 59 FF	y0 50 00 FF y0 50 01 FF y0 50 02 FF	Low Auto High

Shutter Speeds: 0:1/7680, 1:1/3840, 2:1/1920, 3:1/960, 4:1/480, 5:1/240, 6:1/120, 7:1/60, 8:Auto

Notes:

- The Camera module does not support an Auto White Balance option. The selection (Manual/Auto) resets the Red and Blue Gain to defaults.
- Auto White Balance inquiry will return “Auto” if Red and Blue are at default levels, manual if not.
- The Camera module does not support an Auto Exposure option. The Auto selection will reset Contrast, Saturation, Brightness, and shutter speed to defaults.
- Auto Exposure inquiry will return Auto if Contrast, Saturation, Brightness, and shutter are at defaults. Manual if not.

APPENDIX 4: WIDESHOT OSD MENU TREE

Menu	Controls	Range/Modes	Default	Notes
PICTURE	BRIGHTNESS	0-16	8	
	CONTRAST	0-16	8	
	SHARPNESS	0-16	8	Detail
	BKLEVEL (Black Level)	0-16	8	Pedestal Adjustment
	NR (Noise Reduction)	0-16	0	Image Position (side to side)
	HFLIP (Horizontal Flip)	OFF - ON	OFF	To invert camera image H
	VFLIP (Vertical Flip)	OFF - ON	OFF	To invert camera image V
	RETURN			Return to Main Menu
COLOR	REDGAIN	0-16	8	
	GREENGAIN	0-16	8	
	BLUEGAIN	0-16	8	
	REDGREEN	0-16	8	Combination Color Adjustment
	REDBLUE	0-16	8	Combination Color Adjustment
	BLUEGREEN	0-16	8	Combination Color Adjustment
	SATURATION	0-16	8	Chroma
	RETURN			Return to Main Menu
DAY/NIGHT	MODE (not used)	BW - AUTO - COLOR	COLOR	Auto mode automatically drops from Color to B/W when the light level is to low - NOT USED
	DELAY (Time)	0S - 5S - 10S	5S	NOT USED
	RETURN			Return to Main Menu
EXPOSURE	SHUTTER	0-16	8	
	AGC	LOW - AUTO - HIGH	AUTO	Automatic Gain Control
	ANTICR	OFF - AUTO - ON	AUTO	Anti-Color Rolling/Hunting
	AUTOIRIS	OFF - ON	OFF	Lens has Manual Iris
	RETURN			Return to Main Menu
SPECIAL	TITLE	OFF - ON	OFF	
	PAL/NTSC	PAL - NTSC	NTSC	Set to NTSC 50/60 - North America Set to PAL 50/60 - International
	FPS (Frames/Second)	50/60 - 25/30	50/60	Don't use 25/30 unless necessary
	DEFAULT (Sets to Defaults)	Enter		
	RESET (Restarts Camera)	Enter		
	VERSION (Software Version)	201X-XXXX		Firmware build info
	RETURN			Return to Main Menu
EXIT	Exit			Exists OSD Mode

Touchboards

205 Westwood Ave, Long Branch, NJ 07740
Phone: 866-94 BOARDS (26273) / (732)-222-1511
Fax: (732)-222-7088 | E-mail: sales@touchboards.com

vaddio

Toll Free: 800-572-2011 • Phone: 763-971-4400 • FAX: 763-971-4464
www.vaddio.com