



NovoPRO

Wireless Presentation & Collaboration System



User Manual

Version 2.1



205 Westwood Ave, Long Branch, NJ 07740
Phone: 866-94 BOARDS (26273) / (732)-222-1511
Fax: (732)-222-7088 | E-mail: sales@touchboards.com

Table of Contents

1. GETTING STARTED.....	6
1.1 Package contents	6
1.2 Setting up your NovoPRO device.....	7
1.2.1 How to connect your NovoPRO device.....	7
1.2.2 The NovoPRO Home Screen.....	8
1.3 Software download and installation.....	9
2. NETWORK SETUP.....	12
2.1 Hotspot mode	12
2.2 Client mode.....	13
2.2.1 Ports used by NovoPRO	14
3. MAKING A PRESENTATION	16
3.1 Presenting with Windows and Mac PC	16
3.1.1 Step 1: Setup presentation session parameters.....	17
3.1.2 Step 2: Connect to your NovoPRO device.....	18
3.1.3 Step 3: Make a presentation.....	19
3.1.4 Step 4: Presentation management	20
3.1.4.1 Set Moderator mode (<i>Corporate Edition</i> only)	20
3.1.4.2 Role assignment	20
3.1.4.3 Role change, screen preview, and four-way split screen.....	21
3.1.4.4 Pause, resume, and disconnect.....	24
3.1.4.5 Lock/Unlock students' tablets (<i>Education Edition</i> only)	24
3.1.4.6 Terminate session (<i>Education Edition</i> only)	25
3.1.4.7 Polling (<i>Education Edition</i> only)	25
3.1.4.8 Voting (<i>Education Edition</i> only).....	29
3.2 Presenting with iPad.....	31
3.2.1 Step 1: Connect to your NovoPRO device.....	31
3.2.1.1 Connect to your NovoPRO device automatically via QR Code.....	31
3.2.1.2 Connect to your NovoPRO device manually	33

3.2.2 Step 2: Make a presentation.....	36
3.2.2.1 My Note (<i>Education Edition</i> only)	37
3.2.2.2 Presenting an image.....	41
3.2.2.3 Presenting a document (local storage)	43
3.2.2.4 Presenting a document (with Dropbox).....	45
3.2.2.5 Presenting with a browser	48
3.2.2.6 Annotation	50
3.2.2.7 Screenshot and share.....	51
3.2.3 Step 3: Presentation management	53
3.2.3.1 Set Moderator mode (<i>Corporate Edition</i> only)	53
3.2.3.2 Role assignment	54
3.2.3.3 Role change, screen preview, and four-way split screen.....	55
3.2.3.4 Pause, resume, and disconnect.....	58
3.2.3.5 Reset	59
3.2.3.6 Lock/Unlock students' tablets (<i>Education Edition</i> only)	60
3.2.3.7 Terminate session (<i>Education Edition</i> only).....	61
3.3 Presenting with Android tablet	61
3.3.1 Step 1: Connect to your NOVOPRO device	62
3.3.1.1 Connect to your NovoPRO device automatically via QR Code.....	62
3.3.1.2 Connect to your NovoPRO device manually	64
3.3.2 Step 2: Make a presentation.....	66
3.3.2.1 My Note (<i>Education Edition</i> only)	67
3.3.2.2 Presenting an image.....	69
3.3.2.2 Presenting a document (local storage)	71
3.3.2.3 Presenting a document (with Dropbox).....	73
3.3.2.4 Presenting with a browser	75
3.3.2.5 Annotation	77
3.3.2.6 Screenshot and share.....	78
3.3.3 Step 3: Presentation management	79
3.3.3.1 Set Moderator mode (<i>Corporate Edition</i> only)	79
3.3.3.2 Role assignment	79
3.3.3.3 Role change, screen preview, and four-way split screen.....	81
3.3.3.4 Pause, resume, and disconnect.....	83
3.3.3.5 Reset and rename local device	85
3.3.3.6 Lock/unlock students' tablets (<i>Education Edition</i> only).....	86
3.3.3.7 Terminate session (<i>Education Edition</i> only).....	86
3.4 Presenting with Chromebook	87

3.4.1 Step1: Connect to your NovoPRO device	87
3.4.2 Step 2: Make a presentation.....	89
3.4.3 Step 3: Presentation management	89
3.4.3.1 Role assignment	89
3.4.3.2 Role change, screen preview, and four-way split screen.....	90
3.4.3.3 Pause, resume, and disconnect.....	93
3.5 Presenting with the NovoPRO device	94
3.6 User groups	97
3.6.1 Two Ways to organize a group	97
3.6.2 Create a User Group file.....	98
3.6.3 Manage an existing User Group file.....	100
3.6.4 Installing and operating the User Group file	101
3.7 Video file and YouTube streaming.....	104
3.7.1 Application features.....	105
3.7.2 Streaming local video files	105
3.7.3 Streaming YouTube video	106
3.7.4 Video controls	107
4. ADVANCED FEATURES	108
4.1 Moderator credentials	108
4.2 File sharing	112
4.2.1 Opening File Sharing in NovoPRO DesktopStreamer Windows/Mac PC.....	112
4.2.2 Using File Sharing to share a file with participants.....	112
4.2.3 Using File Sharing to share a desktop screenshot PC	114
4.2.4 Receiving a file to your PC with NovoPRO DesktopStreamer.....	114
4.2.5 Troubleshooting and rules to remember with DesktopStreamer PC.....	115
4.2.6 How to send and receive files using NovoPresenter	116
4.2.7 Send a screenshot with Send Screen in NovoPresenter PC.....	118
4.2.8 Receiving files in NovoPresenter	119
4.2.9 Troubleshooting and rules to remember with NovoPresenter PC.....	119
4.3 Remote manager.....	120
4.3.1 Software setup	120
4.3.2 Adding devices	120
4.3.3 Removing a device	121

4.3.4 Refreshing device list	121
4.3.5 Managing device settings.....	121
4.3.6 Uploading a logo	122
4.3.7 Updating firmware	123
4.3.8 Setting moderator credentials	123
4.4 Responding with Voting (iOS, Android, Chromebook)	124
4.4.1 Answering Voting questions with Android phone and tablet	124
4.4.2 Answering Voting questions in iOS (iPhone, iPad).....	125
4.4.3 Answering Voting questions with Chromebook	126
4.5 iOS device mirroring	127
4.6 Android device mirroring	129
5. DEVICE CONFIGURATION	133
5.1 Configure NovoPRO system locally.....	133
5.2 Configure NovoPRO system remotely	136
5.3 Custom configuration file	137
5.3.1 Create and install custom configuration file.....	137
5.3.2 Download and open NovoPROConfig.xml template file.....	138
5.3.3 Fill in the values for personal configuration	138
5.3.4 Add a home-screen logo (optional)	138
5.3.5 Copy and install files	139
5.4 Wi-Fi reconnection	139
6. SPECIFICATIONS.....	140
7. TROUBLESHOOTING.....	141
8. SAFETY INFORMATION.....	143
9. COPYRIGHT INFORMATION	144
10. INDEX.....	145

1. Getting Started

1.1 Package contents

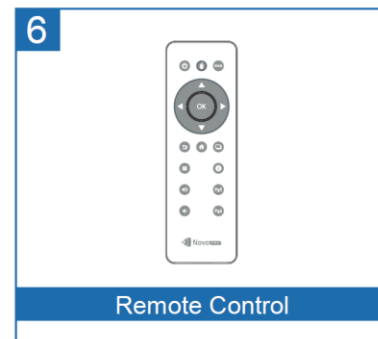
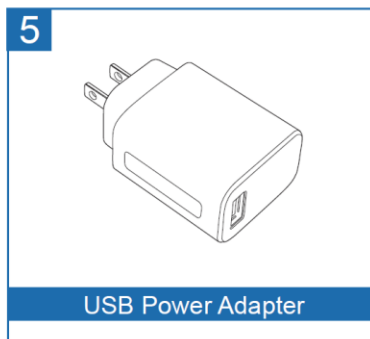
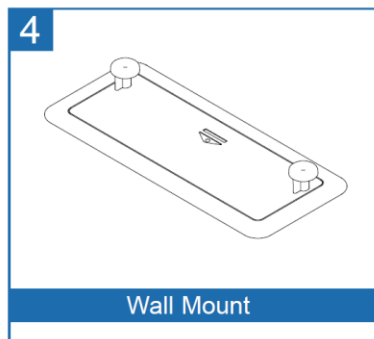
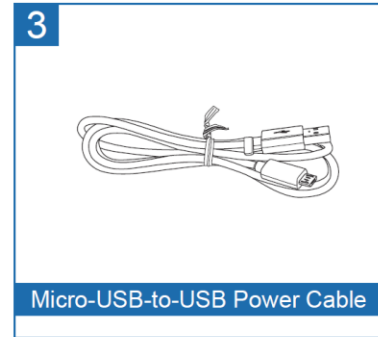
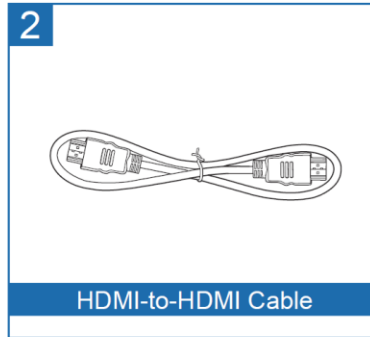

1.2 Setting up your NovoPRO device

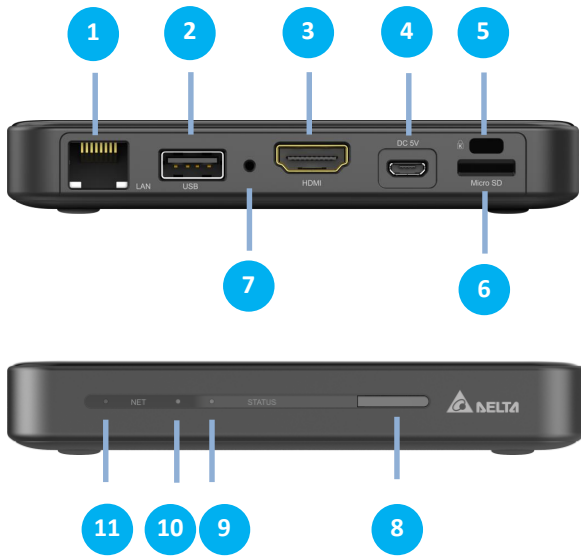

1	RJ45 (Ethernet) Port
2	USB Port
3	HDMI Port
4	DC Power Jack
5	Kensington® Security Slot
6	microSD Card Slot
7	Reset button
8	IR Receiver
9	System Power On (Green)
10	System Standby mode (Red)
11	Network activities

1.2.1 How to connect your NovoPRO device

1. **Video/Audio connection:** Connect the HDMI port to a TV/projector’s HDMI input port using a HDMI-to-HDMI cable (item (2) in “Package Contents.”)
2. **Power:** Connect the Micro-USB port to a power outlet using a Micro-USB-to-USB power cable and a USB power adapter (items (3) and (5) in “Package Contents.”)
3. At this stage the NovoPRO’s green LED power indicator should be illuminated.
(See above illustration for Power LED location.)

Note: In this manual, your NovoPRO will also be referred to as NovoPRO for short.

Note: You may connect an optional USB mouse or a memory drive to the USB port.

Note: The microSD slot supports microSD cards up to 32 GB in FAT32 and NTFS file formats.

1.2.2 The NovoPRO Home Screen

The NovoPRO device will power up with the below display after the step 1 and 2 listed above. This display is referred to as “NovoPRO home screen” or just “home screen” in this document. The home screen is generated by the presentation management software, in the NovoPRO device, which is also known as *remote viewer*.

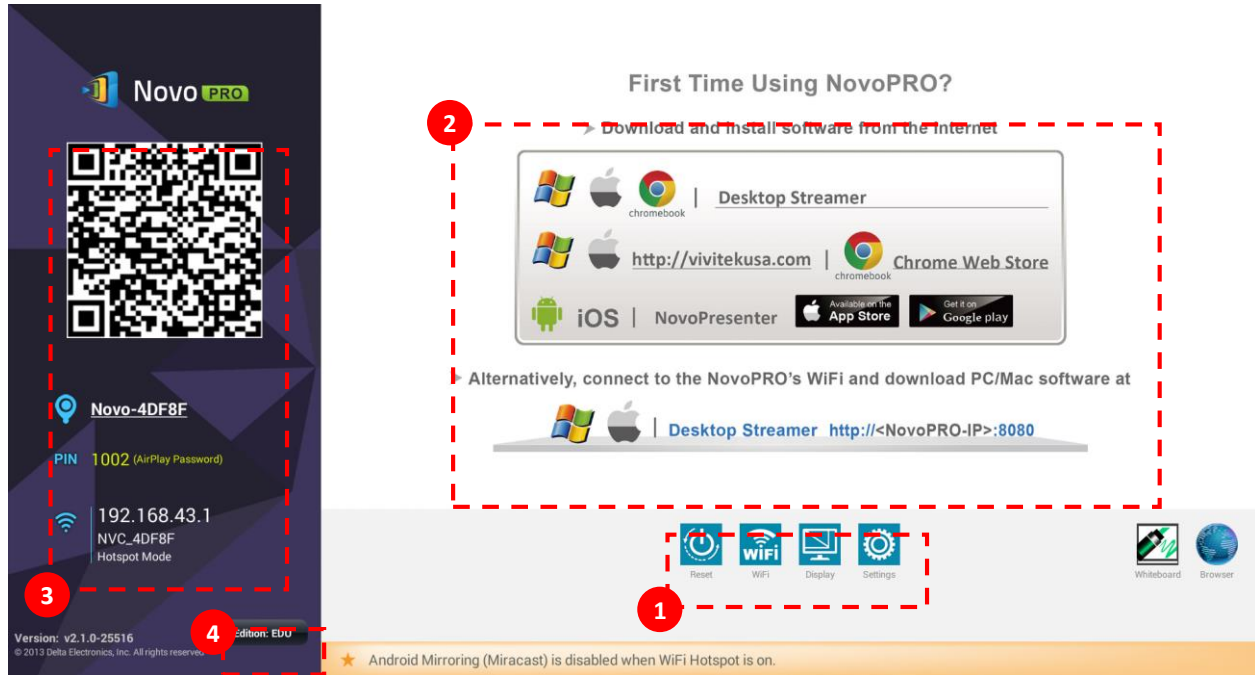

1 Presentation Setup

NovoPRO is default at WiFi Hotspot mode with its SSID name displayed at the home screen (e.g. NVC_4DF8F in box 3). Alternatively, you can connect the NovoPRO to your existing network via a wireless connection and/or a wired connection. You can change WiFi setting via “WiFi” Button. You can also change display setting via “Display” button and other general settings via “Settings” button. For detailed information, please refer to the section 5.1 NovoPRO System Configuration.

2 Software Installation

Windows/Mac Users: Enter the URL displayed on the home screen under “Desktop Streamer” into your web browser and follow the instructions in the next section.

iPad/Android Users: Follow the instructions in the next section.

Chomebook Users: Follow the instructions in the next section.

3 Connection

- Windows/Mac Users: Launch the installed Novo Desktop Streamer application and input the IP address of the NovoPRO device, and PIN (if required) shown on the home screen.
- iPad/Android Devices: Launch the installed *NovoPresenter* App, and then scan the QR code shown on the upper left corner of the NovoPRO home screen or manually input the IP address (and PIN if required) into your *NovoPresenter* App and connect.
- Chromebook Users: Launch the installed *Novo Desktop Streamer* App and input the IP address of NovoPRO device, and PIN (if required) shown on the home screen.

4 Select the Application Edition (optional)

Connect a USB mouse to your NovoPRO. Click the on-screen edition display area to set your NovoPRO to either *Corporate Edition* or *Education Edition*.

The main differences between these two editions are as follows:

Corporate Edition: During a presentation, all *participants* can project screen contents directly onto the NovoPRO screen. One of the *participants* can become the *moderator* to conduct attendance. For more information on the *moderator*, refer to the **Presentation Management** section for your respective device

Education Edition: During a presentation, the *moderator* can preview the screen of any *participant* without needing to first obtain permission, lock the *participants'* tablets, and terminate the session. For more information on the screen preview function refer to the **Presentation Management** section for your respective device.

Note: This manual primarily references the Corporate Edition for instructional examples. Special notes will accompany instructions that are specific to the Education Edition.

1.3 Software download and installation

The NovoPRO device supports connections of up to 64 concurrent *participants* across a mix of PC, Chromebook and tablet devices if it is connected to your existing network (Hotspot mode only supports up to 8 concurrent participants). Each *participant's* device will need to set up a connection through the presentation application, *Remote Viewer*, residing on the NovoPRO to make a presentation. You will need to download and install the following application software:

- On Windows PC - [Novo Desktop Streamer](#)
- On Mac PC - [Novo Desktop Streamer](#)
- On Chromebook – [Novo Desktop Streamer](#)
- On iOS tablet – [NovoPresenter](#)
- On Android tablet – [NovoPresenter](#)

Note: Throughout the document, these five presentation applications and the *NovoPRO Remote Viewer* software are highlighted in *italics type*.

Downloading the presentation software for Windows PC and Mac PC

Enable Wi-Fi on the computer, and click the wireless network icon . Select the NovoPRO SSID on the NovoPRO home screen (for example, NVC_4DF8F) and click Connect or Join. Ignore all security warnings.

Launch your preferred Web browser on your PC and enter the URL displayed on the NovoPRO home screen. For the example home screen shown above, you would enter <http://192.168.43.1:8080> into the address line of the browser. The following screen will be displayed on your browser.

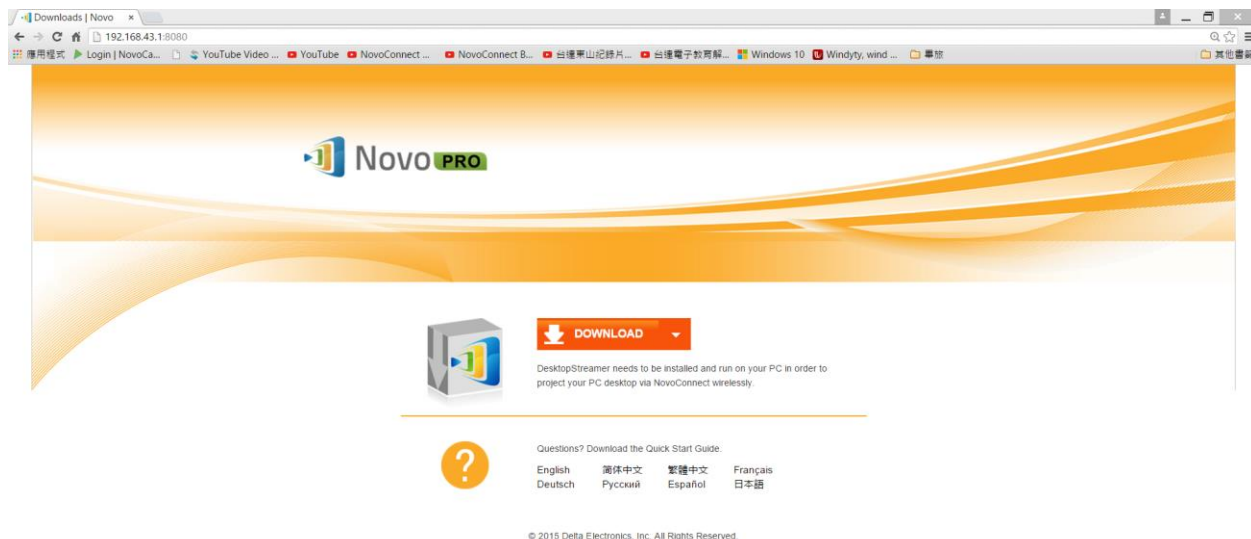

Select the appropriate operating system from the drop-down menu and then click the **DOWNLOAD** button to download the Novo Desktop Streamer software to your PC.

Installing the application software for Windows PC and Mac PC

Install either *Desktop_Streamer_Setup_Windows.exe* (for MS Windows based computers) or *Desktop_Streamer_Setup_Mac.exe* (for Macintosh computers) by double clicking the downloaded file on your computer. Follow the installation instructions on the PC to complete the installation and allow all security permissions for Novo Desktop Streamer and all of its subcomponents.

The computer is now ready to make a wireless presentation with your NovoPRO.

Downloading and installing the presentation software for Android and iOS tablet devices

On iOS tablets, the iOS version of *NovoPresenter* is required. You can download and install it from the Apple App Store.

On Android tablets, the Android version of *NovoPresenter* is required. You can download and install it from the Google Playstore.

Downloading and installing the presentation software for Chromebook devices

On Chromebook, a *Novo Desktop Streamer* App is required. You can download and install it from the Google Chrome Web Store.

Once you have downloaded and installed the presentation software, you are ready to make a wireless presentation from your PC/Chromebook/tablet device.

2. Network Setup

Depending on where your presentation content is located and the number of *participants* in the presentation, you may select one of the following connection modes from the NovoPRO home screen.

A) Client Mode – for when your content is residing in a private cloud or the Internet cloud, and the number of *participants* is more than eight

B) Hotspot Mode – for when your content is residing on your PC or tablet, and the number of *participants* is eight or fewer

C) Neither – for when your content is stored on your microSD card

The NovoPRO defaults to start up in Wi-Fi Hotspot mode, which is the most direct way to create a wireless presentation without using a Wi-Fi access point (AP) or connecting to a wired network. If this is your preferred mode, go to section 2.1 “Hotspot Mode” for steps on making a presentation.

If you would prefer to make your presentation through an existing network (either wireless or wired), please refer to section 2.2 “Client Mode” in this chapter.

2.1 Hotspot mode

Right out of the box, NovoPRO’s Wi-Fi is set to function as a Wi-Fi Hotspot and will stay in this configuration until you alter it. The default SSID for the Wi-Fi hotspot is “NVC_XXXXX”, where “XXXXX” is a device-generated string of characters and numbers. A USB mouse is required for the following steps.

If you alter your settings and then choose to revert to Hotspot Mode, on the NovoPRO home screen, select **WiFi-> Hotspot Mode->Apply**.

For a PC to connect to the NovoPRO Hotspot, click the network icon  on task bar. Select the SSID of the NovoPRO device shown on the home screen (for example, NVC_DC9AB) and click **Connect**.

For a Mac to connect to the NovoPRO hotspot, click the network icon . Select the SSID of the NovoPRO device shown on the home screen (for example, NVC_DC9AB) and click **Join**. Ignore any security warnings.

For a tablet to connect to the NovoPRO hotspot, enable Wi-Fi and go to the Wi-Fi AP list. Select the SSID of the NovoPRO device shown on the home screen (for example, NVC_DC9AB).

For a Chromebook to connect to the NOVOPRO hotspot, click the network icon . Select the SSID of the NovoPRO device shown on the home screen (for example, NVC_DC9AB) and click **Connect**.

Note: When operating in Hotspot Mode, all participating presentation devices must be connected to the same NovoPRO Wi-Fi hotspot.

Note: Up to eight simultaneous participants are supported in Hotspot Mode.

2.2 Client mode

Please consult your organization IT administrator on how to connect a NovoPRO device into to the existing network securely.

Generally speaking, in this mode, the NovoPRO device functions as a client to join an existing network. You can connect your NovoPRO to a Wi-Fi AP for wireless connectivity or an Ethernet Switch for wired network connectivity. A mouse is required for the following steps.

Wireless Network

On the home screen of the NovoPRO, first select **WiFi->Connect to WiFi -> Config->Wireless & Networks-> Wi-Fi (ON)**, and then select the desired Wi-Fi AP SSID (the name associate with the Wi-Fi network). Enter a password if prompted.

Wired Network

Once being connected to a wired network via the NovoPRO's RJ45 port, it should automatically get an IP address from your organization's DHCP server.

Both wired and wireless network

NovoPRO can even be connected to both your organization's wired network and wireless network simultaneously. This function is extremely useful for some organizations with "guest" wireless network setup for external visitors. In such a case, the NovoPRO's RJ45 port is connected to a wired EMPLOYEE network for organization internal employee to securely access it; at the same time NovoPRO's WiFi is configured to connect to a GUEST network to allow external visitors to access it. The following graph describes such a network setup scenario.



By doing so, you still keep the GUEST and EMPLOYEE networks separated, and at the same time, the NovoPRO device is available to both your guest users and employees.

Notes on Network Security: Inside the NovoPRO device, the WiFi section is completely separated from the Ethernet section, namely, there is no network routing between these two sections. Therefore, users connecting to the WiFi section will not be able to access any resource on the Ethernet at all, and vice versa. In short, security is not compromised in this configuration.

2.2.1 Ports used by NovoPRO

NovoPRO is a TCP/IP-network-based device, and the communications between a NovoPro device and its client devices (e.g. laptops, tablets, etc.) are achieved through several TCP and UDP ports. The following table summarizes all the port numbers being used.

Port Number	Type	Description
20121	TCP	Port to transfer commands and status reports between the NovoPRO unit and users' devices. (For example, laptops/tablets use this port to establish "connection" to the NovoPRO unit.)
20122	TCP	Port to enable "Remote Mouse" functionality
20123	TCP	Port to transfer screen image
20124	UDP	Port to send discovery message (so that the NovoPRO unit can be discoverable by laptops/tablets.)
20125	TCP	Port to transfer preview image
20126	TCP	Port to transfer AV-streaming's command data
20127	TCP	Port to transfer AV-streaming's audio data

20128	TCP	Port to transfer AV-streaming's video data
20129	TCP	Port to transfer voting/polling data
20130	TCP	Port for video streaming service
20131	TCP	Port for file transfer service
20141	UDP	Port for device management

To enable successful operations of a NovoPro device, the above ports should not be blocked by your network's firewall.

3. Making a Presentation

The NovoPRO device supports up to 64 concurrent *participants* across a mix of PC, Chromebook and tablet devices. To make a presentation, each *participant's* device will need to connect to the NovoPRO and join the presentation group hosted by the NovoPRO. There are four key features that help facilitate smooth collaboration and coordination of presentations using the NovoPRO:

- 1) A *participant* list is included with the individuals' roles indicated by clear graphical representation.
- 2) A specific capability is defined for each role.
- 3) The split screen for simultaneous presentation of multiple participants.
- 4) Annotation tools allow participants to highlight, draw or make notations on the display screen.

3.1 Presenting with Windows and Mac PC

Launch Presentation Application

Launch the *Novo Desktop Streamer* Application by double clicking the  icon. Once launched, the *Novo Desktop Streamer* will appear as follows.

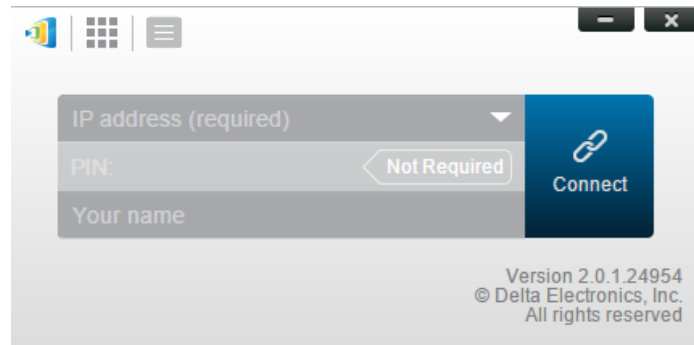



To make a presentation, follow the steps listed below:

- Step 1: Setup presentation session parameters
- Step 2: Connect to your *NovoPRO* device
- Step 3: Make a presentation
- Step 4: Manage the presentation

3.1.1 Step 1: Setup presentation session parameters

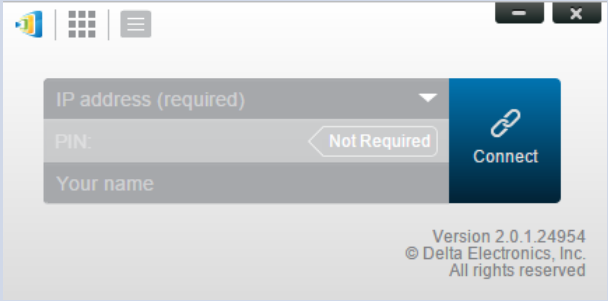
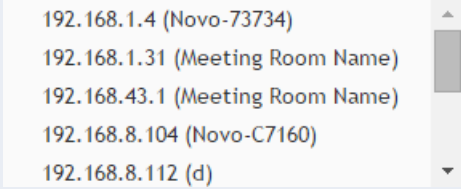
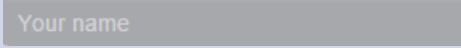
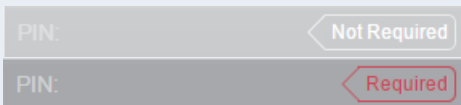
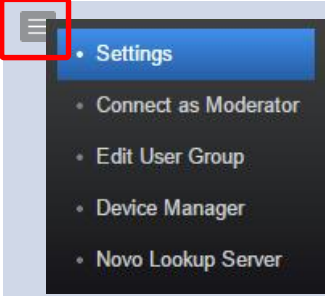
Before clicking the connection button , some presentation session parameters should be setup as shown below.

Function	Description
	<p>The first popup window of <i>Novo Desktop Streamer</i> Application.</p>
	<p>Manually enter the IP address shown on the NovoPRO home screen, or select an IP address entry from the drop-down menu that matches the IP address shown on the NovoPRO home screen.</p>
	<p>(Optional) Manually enter a name for this computer to be identified in the presentation group among other <i>participants</i>. Example: Kevin (Note: If a name is not entered in this field, the default name of your device will be used.)</p>
	<p>If PIN is required for a presentation group, check the “PIN required” box and enter the four-digit PIN shown on the home screen.</p>
	<p>Click  to expand the Settings tab to access additional settings options.</p>

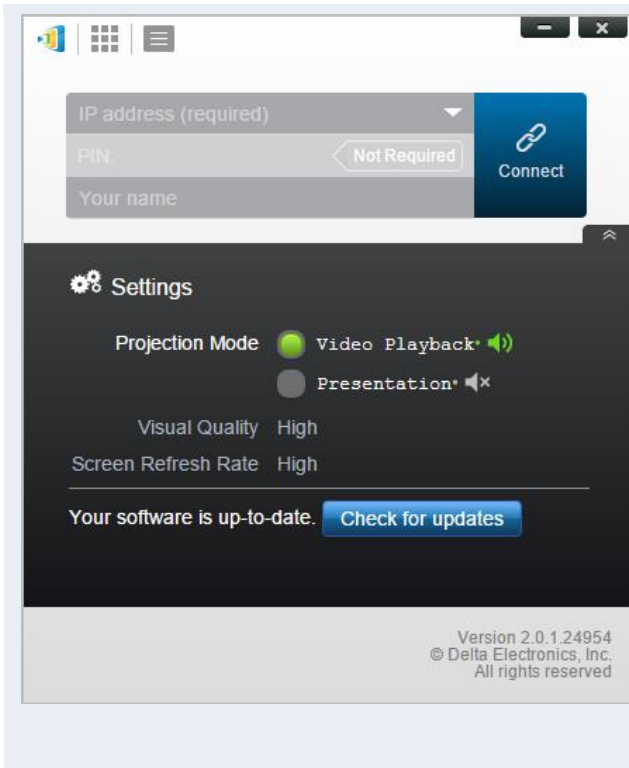

1. Projection Mode:

Video Playback: Select this option for a higher frame rate screen mirroring and to turn on audio transmission.

Presentation: Select this option for document presentation or browser content presentation. The audio will be automatically set to off. Two additional drop-down configurations, *Visual Quality* and *Screen Refresh Rate*, will be enabled.

2. Visual Quality:

High: This setting yields the best visual quality but has the most latency and may result in longer video delay.

Normal: This setting yields the normal visual quality with the normal CPU consumption.

3. Screen Refresh Rate:

High: This setting yields the enhanced visual quality but results in higher CPU consumption.





Normal: This setting yields the normal visual quality with the normal CPU consumption.

4. Check for updates:

Click to check whether *Novo Desktop Streamer* is the latest. If not, initiate an upgrade process.

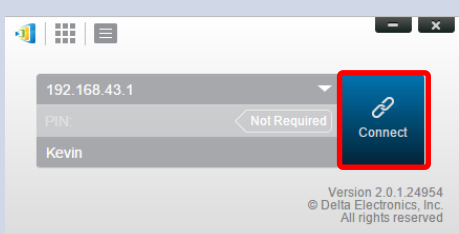
3.1.2 Step 2: Connect to your NovoPRO device

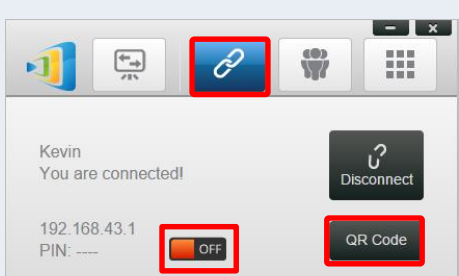
Once you have setup presentation session parameters, you are ready to start or join a presentation group with your *NovoPRO*.

Function	Description
	<p>Connect to your <i>NovoPRO</i> device.</p> <p>Click the  button. If you are the first <i>participant</i>, this will start a presentation group on your <i>NovoPRO</i>. If you are not the first <i>participant</i>, you will be joining a presentation group.</p>
	<p>After your <i>Desktop Streamer</i> is connected successfully to your <i>NovoPRO</i>, you will see the connection tab light up .</p> <p>If you are the first <i>participant</i>, you will see that your PC's on-screen display is wirelessly mirrored on your projector or TV display. You can also slide the PIN requirement switch to OFF or ON to enable the use of an access PIN code for the presentation group.</p>



If you are the first *participant* you may allow other users to join the presentation group via QR code by clicking **QR Code** to display the QR code and session information windows for others to quickly connect to your *NovoPRO*.

Please note that your PC screen resolutions may change to match projector resolution. After disconnecting from the NovoPRO device, the original screen resolution will be restored. This will occur for all PCs in the same presentation group.

3.1.3 Step 3: Make a presentation

Once you have started/joined a presentation group you can make a presentation with the contents stored on your PC, local network, or the Internet. Your desktop screen will be mirrored to the NovoPRO display regardless of the applications you are running on your PC.



There may be situations in which you want to write, highlight, mark, record video or cut-and-paste portions of your presentation materials directly on the desktop screen. DELTA Electronics, Inc. provides a simple-to-use tool for all of these functions – *NovoScreenote*.

NovoScreenote is a simple yet powerful screen annotation and recording software with the following features:

- (*Education* Edition only) Write, type or draw on the desktop screen over any running application such as MS Office, a PDF reader, a photo viewer or a video player.
- Save or email your annotations.
- Record the whole session as a video clip.

You can download the Windows PC or Mac PC versions of *NovoScreenote* from <http://www.deltaww.com/EduSolution>.

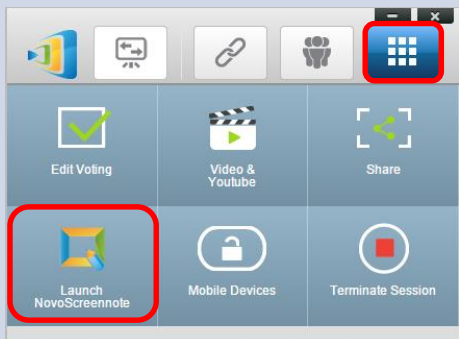



After you have installed *NovoScreenote*, you can launch it from your Novo Desktop Streamer.

Function	Description
	<p>Launch NovoScreennote:</p> <p>Click the  tab to bring up the toolbar page, then click Launch NovoScreennote.</p>

3.1.4 Step 4: Presentation management

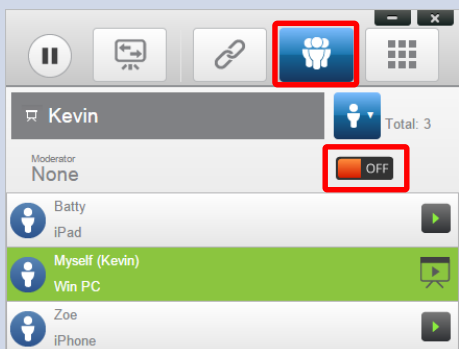
3.1.4.1 Set Moderator mode (*Corporate Edition only*)

This feature is only available in the Corporate Edition. It allows anyone to enter moderator mode, but the preview function has been disabled. It works with both PCs and tablets.

Function	Description
	<p>Set the moderator mode:</p> <p>Click the  tab and click the Moderator On/Off switch to turn the moderator function on or off</p> <p> OFF : The moderator mode is off.</p> <p> ON : The moderator mode is on.</p>
	<p>Manage presentations or make a presentation:</p> <p>After the moderator mode is turned on, the moderator will now have the authority to manage attendance or make a presentation in split screen.</p>

3.1.4.2 Role assignment









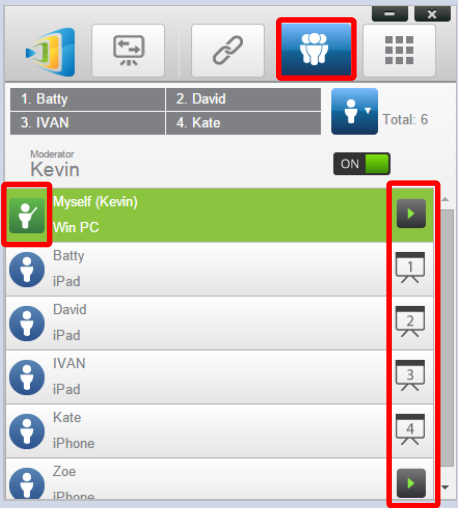

There are three roles in a presentation group, the *moderator*, the *presenter*, and the *participant*.

The first *participant* to start the presentation group is assigned the *moderator* role. Subsequent individuals that join are assigned the *participant* role.

At first, the *moderator* is defaulted to assume the *presenter* role until he hands over the *presenter* role to another *participant*.

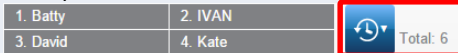
To show all current *participants* who have joined the presentation group, click the  tab.

(Note: For Education Edition all participants will automatically allow screen preview.)

Function	Description
	<p>Click the  tab to show the participant list.</p> <ul style="list-style-type: none">  indicates the current <i>moderator</i>.  indicates a <i>participant</i>.  indicates the current <i>presenter</i>.  indicates the current <i>presenter</i> that is being presented in the indicated split-screen box number (#1-4) (the icon shown here is for a <i>presenter</i> that is presenting in Box #1). <p>For the <i>Education Edition</i>, all participants will automatically allow screen preview.</p>
<p>Example 1:</p>  <p>Example 2:</p> 	<p>Indicate the names of the presenters, the participant list sorting method, and the total number of <i>participants</i>.</p> <p>For the participant list sorting method,  indicates that the list is sorted by participants' name in reverse alphabetical order.  Indicates that the list is sorted by the presentation group join time (most recent on top).</p> <p>Toggle between  or  to change the participant list sorting method.</p> <p>Example 1: Kevin is the only <i>presenter</i>. The participant list is sorted by participants' name in reverse alphabetical order. There are currently 6 <i>participants</i>.</p> <p>Example 2: Batty, Ivan, David and Kate are 4 <i>presenters</i>. The participant list is sorted by the presentation group join time (most recent on top). And there are currently 6 <i>participants</i>.</p>

3.1.4.3 Role change, screen preview, and four-way split screen

(Note: For Education Edition all participants will automatically allow screen preview.)

Function	Description
	<p>Role change: change a participant to a moderator</p> <p>Click the  tab to list all participants. If you want to transfer <i>moderator</i> role to another <i>participant</i>, please move your mouse cursor to that participant's  icon, and click the icon.</p> <p><i>Please note: only the moderator is allowed for this operation.</i></p>
<p>The <i>moderator's</i> screen:</p>  <p>The <i>participant's</i> screen:</p> 	<p>A dialog box pops up to ask for your confirmation. You have 20+ seconds to click the Yes button to accept or click the No button to reject the requested <i>role change</i>.</p> <p>At the same time, a dialog box will appear on that <i>participant's</i> screen to ask for his/her confirmation. The <i>participant</i> has 20+ seconds to click the Yes button to accept or click the No button to reject the requested role change.</p>
	<p>Role change: change to be a sole presenter</p> <p>Click the  tab to list all participants. If you want to promote one participant to be a presenter, please move your mouse cursor to that participant's  icon, and click the icon. A bigger icon window pops up, and please click the middle part illustrated below to pass presentation role to that participant.</p> 
	<p>When a <i>participant</i> is asked to be a <i>presenter</i>, a dialog box will appear on the <i>participant's</i> screen. The <i>participant</i> has 20+ seconds to click the Yes button to accept or click the No button to reject the requested role change.</p>

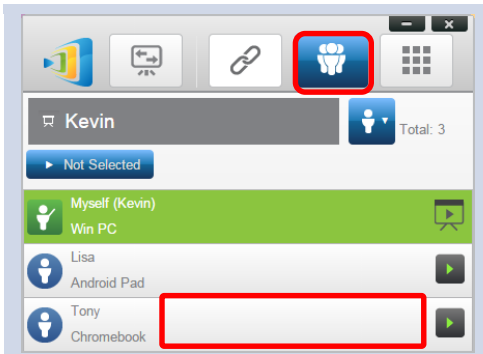

To perform screen preview (Education edition only):

1. Click the  tab to view the *participant* list.
(Note: Only the *moderator* can preview the *participant's* screen.)
2. Move your mouse over to one participant's button and click the middle part of that button.

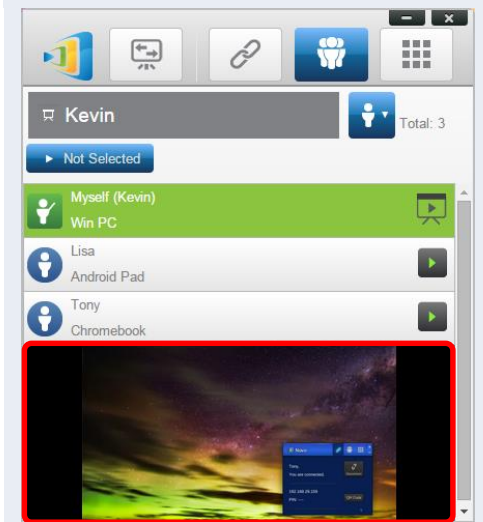

That participant's screen will be shown under his/her name.

You can click the middle of the button to close screen preview.

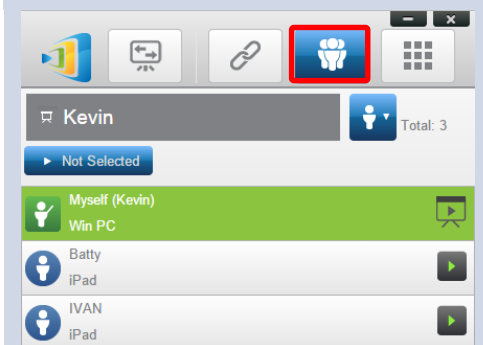

To perform a four-way split screen presentation:

Click the  tab to view the *participant* list.
(Note: only the *moderator* can designate a four-way split screen presentation.)

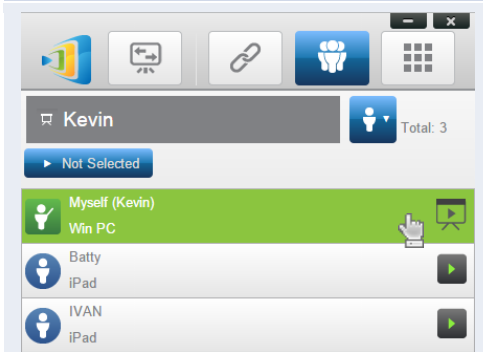

1. Move cursor over to highlight *participant* Kevin.



2. Click on a numbered box to assign a *presenter's* on-screen display to the corresponding presentation screen (numbers 1-4).

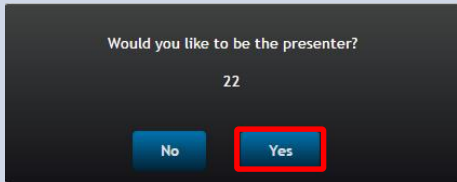

In the dialog box, we see that Kevin has received a request to assume the *presenter* role.

After Kevin clicks **Yes** to accept being a *presenter*, Kevin's screen will appear in one of the four quarters of the four-way split screen.



3.1.4.4 Pause, resume, and disconnect

(Note: For Education Edition all participants will automatically allow screen preview.)

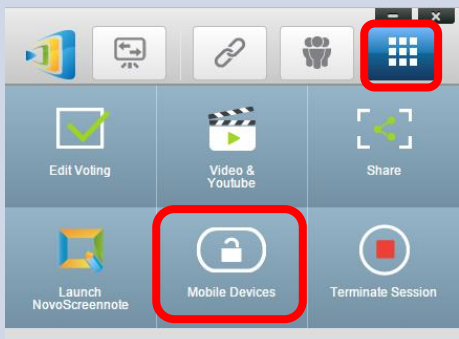

Function	Description
	<p>To pause/resume a presentation:</p> <p>Click the tab to bring up the presentation control page.</p>
	<p>Pausing and resuming a presentation:</p> <p>Move your mouse cursor onto the tab. Toggle between and to pause and resume a presentation respectively.</p>
	<p>To disconnect from a presentation group:</p> <p>Click the button to exit the presentation group.</p> <p>If the <i>moderator</i> exits a presentation group without handing over the <i>moderator</i> role, all <i>participants</i> will receive a message prompting them to take over the <i>moderator</i> role. The first to respond to the prompt will assume the <i>moderator</i> role.</p>

3.1.4.5 Lock/Unlock students' tablets (*Education Edition* only)

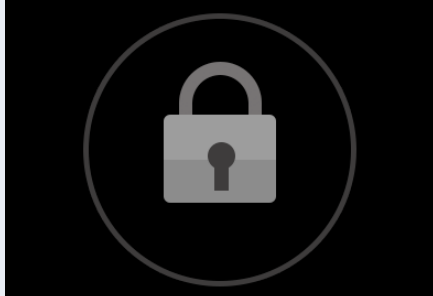
This feature for PCs and tablets allows teachers to lock down student tablets. This feature is only available in the *Education Edition*.

Function	Description
	<p>To lock/unlock mobile devices:</p> <p>Click the  tab to bring up the toolbar page, then click Mobile Devices to lock or unlock mobile devices.</p> <p> : mobile devices are unlocked.</p> <p> : mobile devices are locked.</p>
	<p>Mobile device locked:</p> <p>A lock icon will pop up on all mobile device' screens to show that the screen has been locked.</p>

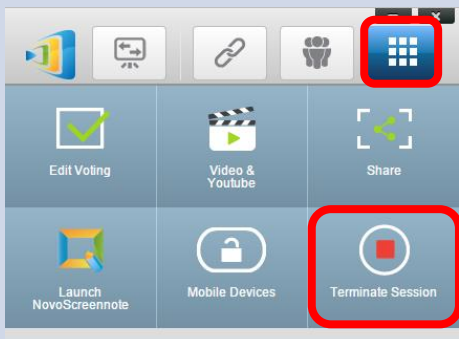
3.1.4.6 Terminate session (*Education Edition only*)

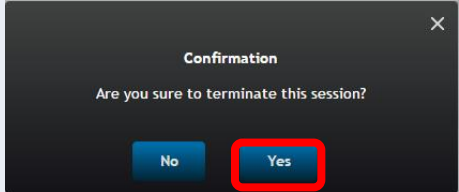
Function	Description
	<p>To terminate the session:</p> <p>Click the  tab to bring up the toolbar page, then click Terminate Session.</p>
	<p>Confirmation:</p> <p>Click Yes to terminate the session. All devices will be disconnected.</p>

3.1.4.7 Polling (*Education Edition only*)

Polling allows moderators or teachers to create sets of questions or quizzes to present to a group or class when used with the Voting feature.

Creating a quiz or question set with voting

1. Click on the “Tools” tab and select “Edit Voting.” This will open the Voting window.

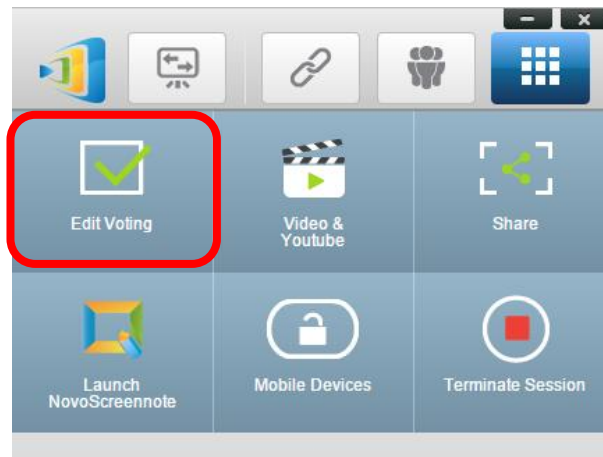

2. To create a new question set or quiz, select “New.” This will open a set of windows to create the first question.

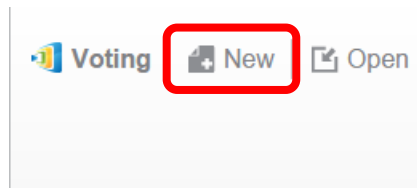

3. Enter the text of your question by clicking on the top text window. If the question is a multiple choice question, you can list the possible answers in this area below the question. Be sure to list the possible answers as “A.”, “B. “, “C.,” etc.

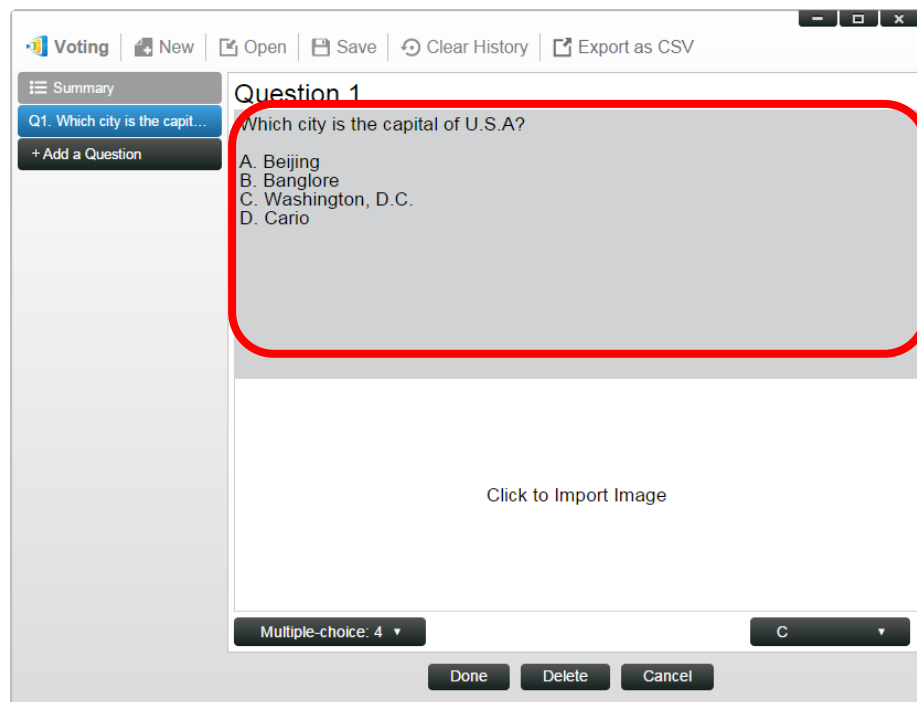

- If you wish to include an image with your question, click on the window below the text window. This will allow you to locate an image on your computer.

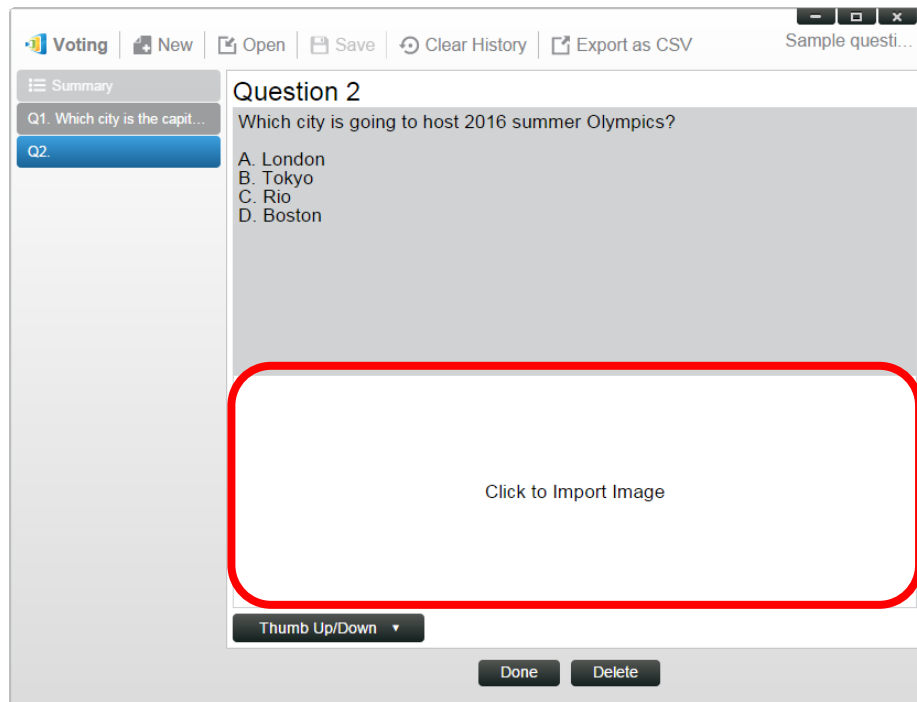

- Select the image (.png, .jpeg, .jpg) and click "Open." The image should now appear in the window below your question.

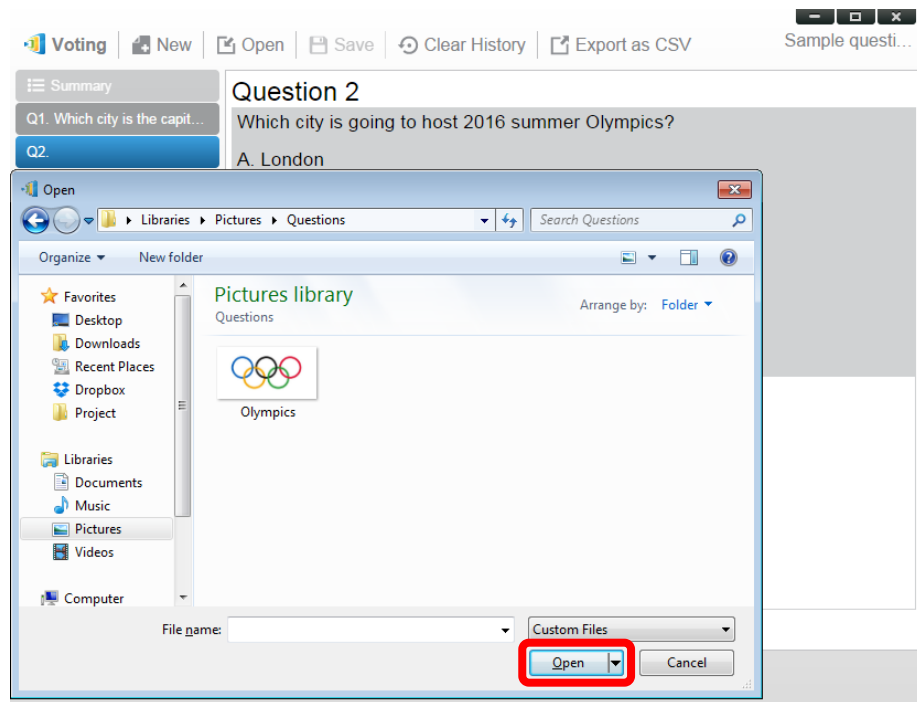

- Choose the type of question from the "Type" pull-down menu.

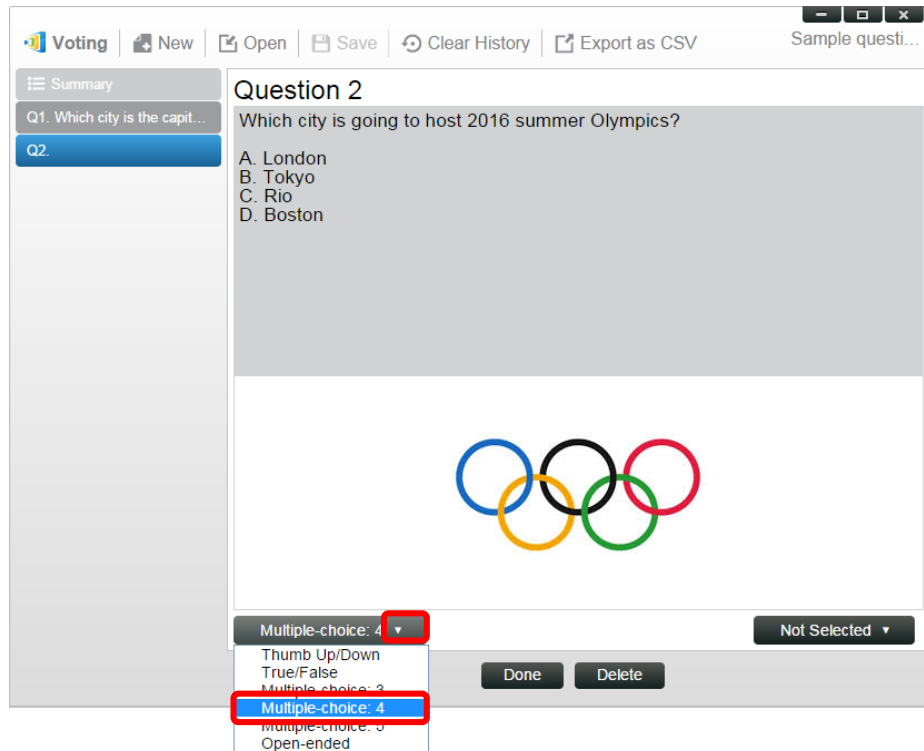

7. Select the correct answer from the “Answer” pull-down menu. If the question is a type where there is no correct answer (such as an opinion poll), you can choose “Not Selected”. Open-ended question have no answer selection option.

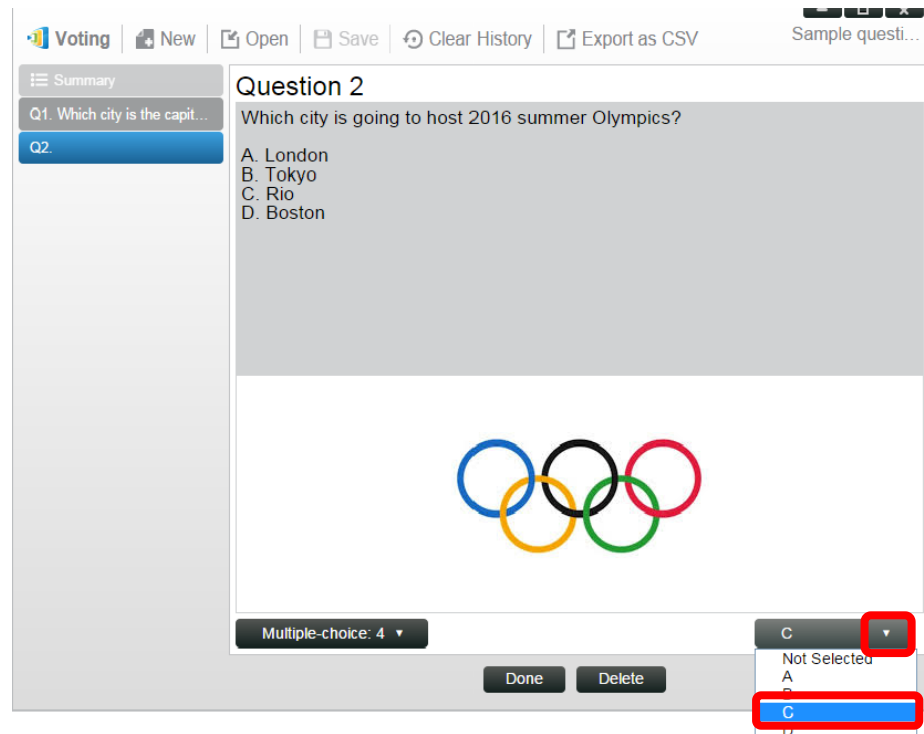

8. To add another question, click on the “+ Question” button in the lower left corner.



- When the group of questions or quiz is complete, save it by clicking the “Save” tab.

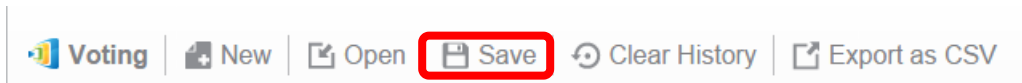

- Name your quiz and select a save location on your computer. This will create a database (.db) file that can be opened, edited or administered through the Voting feature.
- You can also create a CSV file of your poll or quiz by clicking “Export as CSV.”

3.1.4.8 Voting (*Education Edition only*)

- Voting allows a moderator or teacher to administer a poll or test created with the polling function to members of a group or students in a class.
- Voting allows group participants or students to respond to questions from their devices.
- Moderators or teachers can monitor results in real time.

Asking questions with Voting (Windows PC and Mac only)

- Click on the “Tools” tab and select “Edit Voting.” This will open the Voting window.

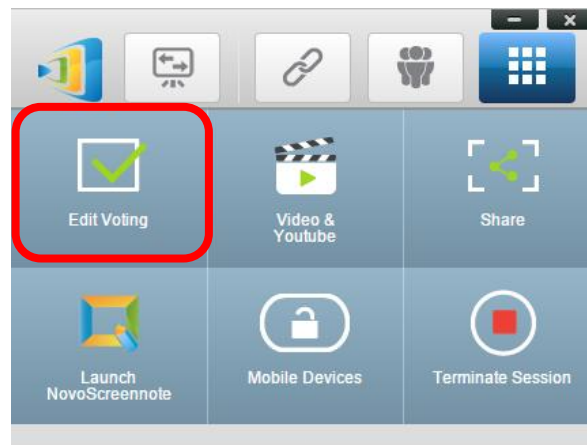

- Open a pre-made set of questions or create a new one by following the steps in the Polling section.
- Select a question and click “Start” to send that question to the participants or students. The question will appear on the screens of their devices.

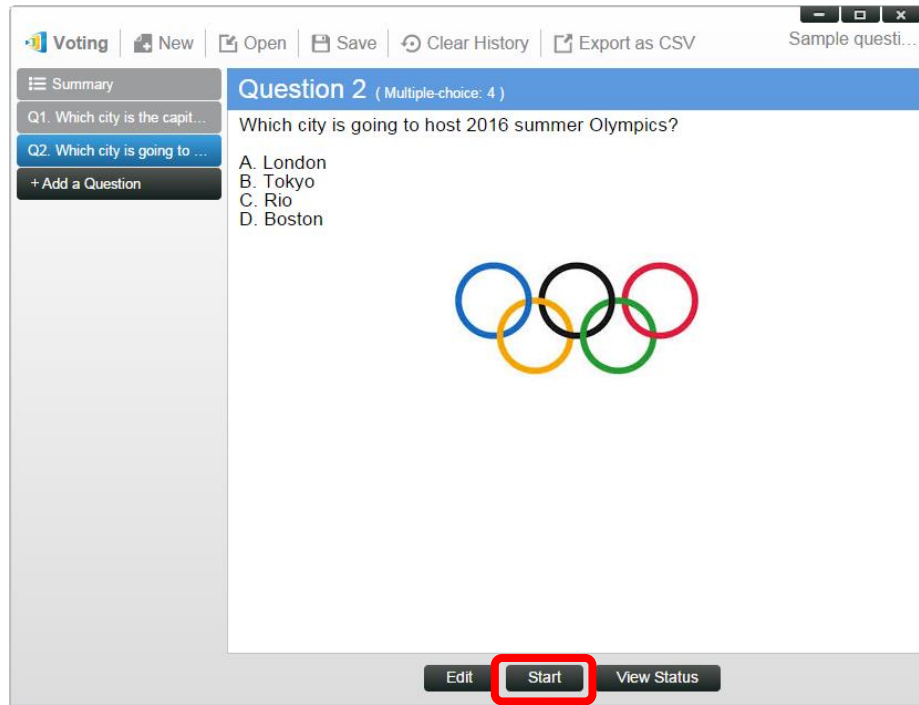

- As the students or participants answer the questions, the teacher or moderator can monitor the results by clicking the “View Status” button. With the status window open, the moderator can see how many students have responded to the question, as well as how each participant responded.

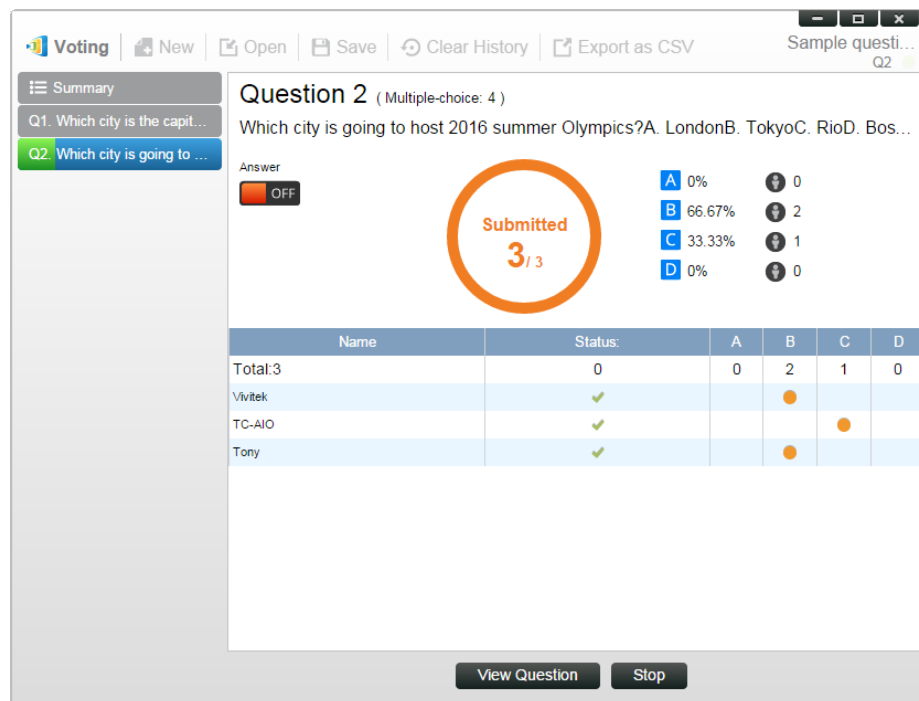

- To return to the question, click “View Question.”
- To send another question to the class, select a new question from the poll and click “Start.”

3.2 Presenting with iPad

The iOS version of the *NovoPresenter* app (pictured in the image below) enables an iPad device to connect to the NovoPRO and make a presentation.



Launch Presentation Application

Launch the *NovoPresenter* application by selecting the *NovoPresenter* app icon  on your iPad. The *NovoPresenter* app will launch.

To make a presentation, follow the steps below:

Step 1: Connect to your NovoPRO device

Step 2: Make a presentation

Step 3: Manage the presentation

3.2.1 Step 1: Connect to your NovoPRO device

There are two ways to connect to your NovoPRO device:

1. Connect to your NovoPRO device automatically via QR code.
2. Connect to your NovoPRO device manually.

3.2.1.1 Connect to your NovoPRO device automatically via QR Code

This is the default NovoPRO connection option which allows you to connect to your NovoPRO automatically without any manual configurations. After launching the *NovoPresenter* app, tap the



tab (as seen in the screenshot below) and access the connection options.

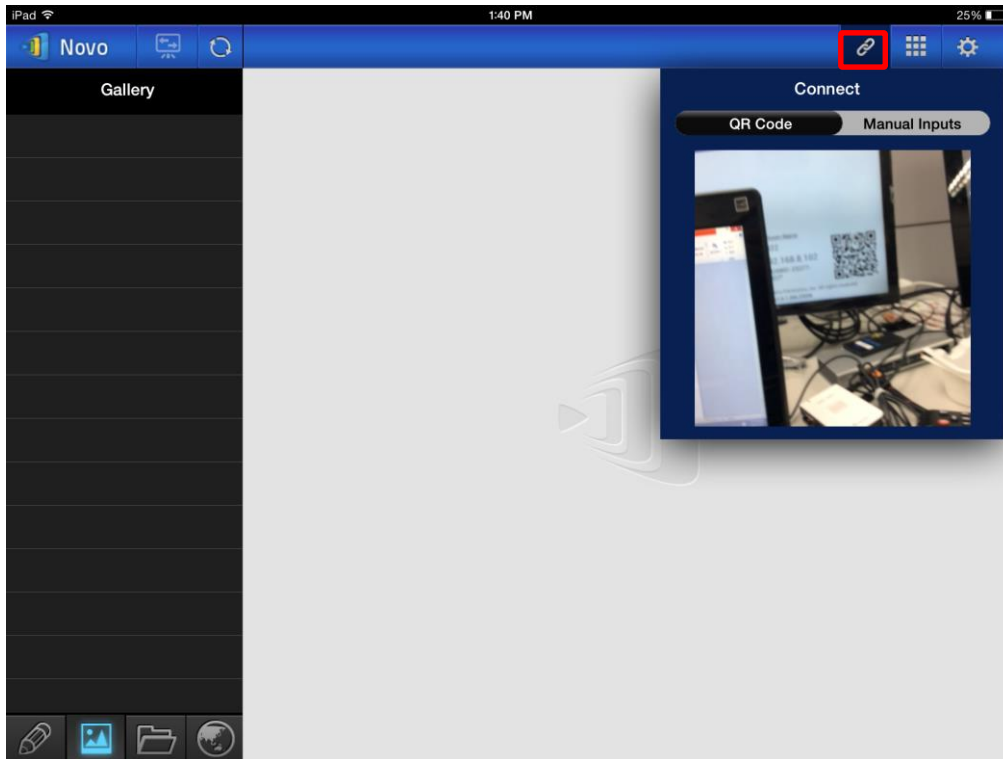

Function	Description
	<p>Connect to the NovoPRO automatically via QR Code:</p> <p>The QR Code / Manual Inputs switch will be in the QR Code position by default (if not, just tap the switch once).</p> <p>Aim your tablet's camera at the QR code containing login information, which can be found on your NovoPRO home screen or on the screen of the device connected to your NovoPRO. Under normal circumstances, <i>NovoPresenter</i> will automatically login to your NovoPRO.</p> <p>Should automatic login fail, follow the manual configuration option in section 3.2.1.2 Connect to your NovoPRO device manually.</p>

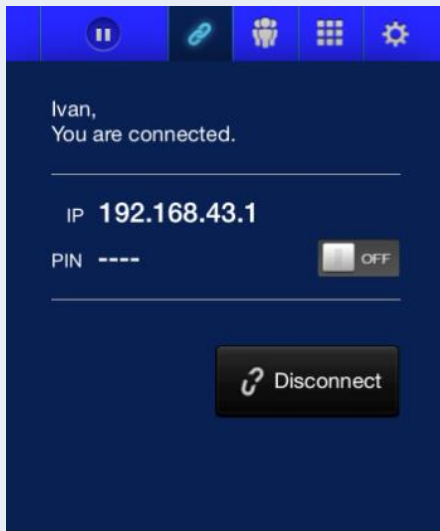

Confirm connection:

After your *NovoPresenter* app on your iPad is connected successfully to your NovoPRO, the connection tab will light up blue .

If you are the first *participant*, you will see that your iPad's on-screen display is wirelessly mirrored on your projector or TV display. You can slide the PIN requirement switch to **OFF** or **ON** to disable or enable usage of a PIN code.

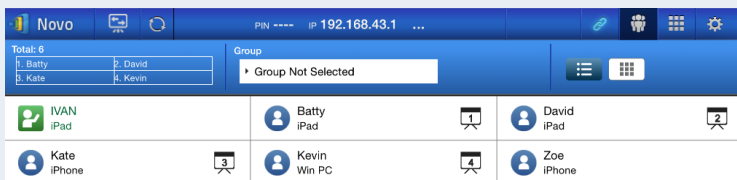

View participants list:

You can tap the  tab to see the current participant list.

Example: There are a total of six *participants* in the presentation group shown at left. The *moderator* is Ivan. However, Ivan is not making a presentation at the moment because he has assigned Batty, David, Kate, and Kevin to be the four *presenters*.

3.2.1.2 Connect to your NovoPRO device manually

If you need to configure login information manually before connecting to your NovoPRO, this is the preferred connection option. After launching the *NovoPresenter* app, tap the  tab (as seen in the screenshot below) to access the configuration options.

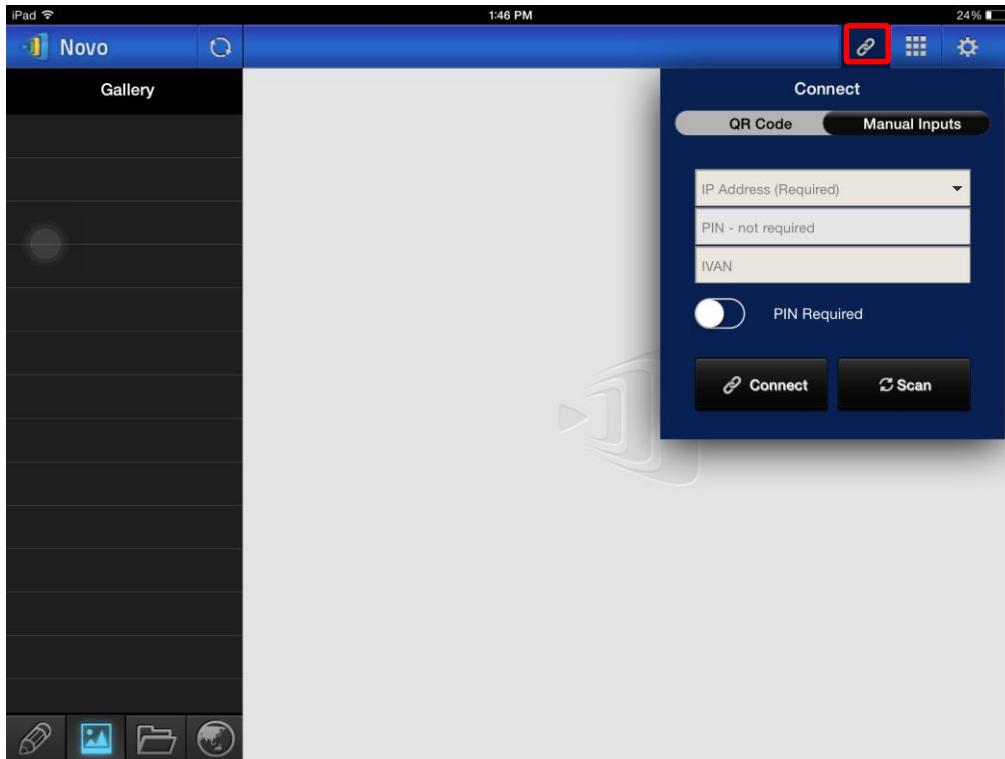

(Note: For Education Edition all participants will automatically allow screen preview.)

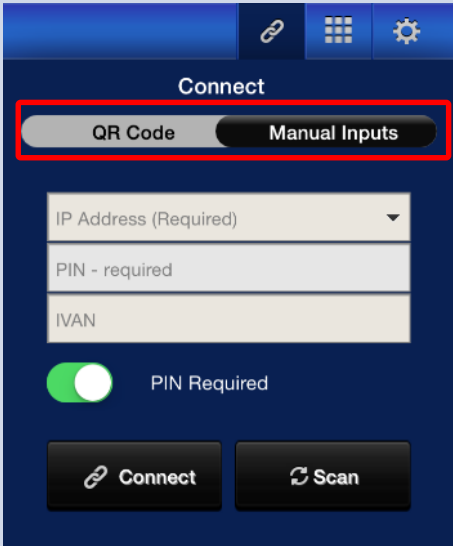
Function	Description
	<p>Manual configuration option: Toggle the QR Code / Manual Inputs switch to the Manual Inputs position.</p>

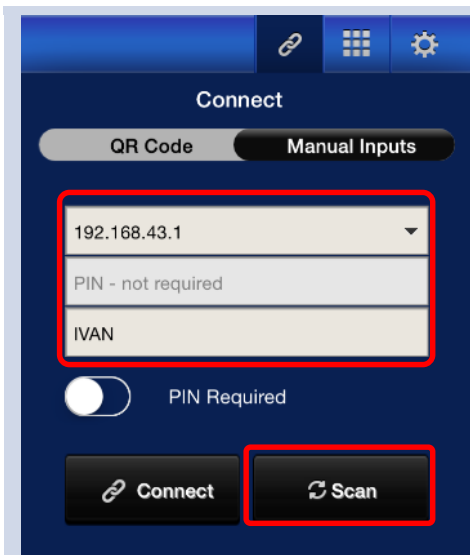

IP Address:

Manually enter the IP address shown on your NovoPRO home screen here, or select an entry from the drop down menu that matches the IP address shown on your NovoPRO home screen.

You can tap the **Scan** button to scan the IP addresses of all available NovoPROs within the same subnet. Select the drop-down menu to see the available NovoPROs within your area.

Example: 192.168.43.1.

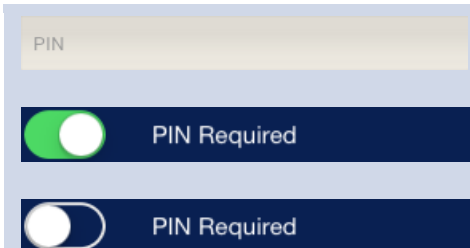

PIN:

If a PIN code is required to connect to the NovoPRO, slide the **PIN Required** switch to the ON position and enter the PIN shown on the NovoPRO home screen. If the PIN code is not required, slide the **PIN Required** switch to the OFF position.

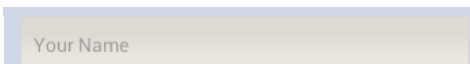

Your Name:

(Optional) Manually enter a name for this tablet to be identified by in the presentation group among the other *participants*.

Example: Jennifer.

(Note: If a name is not entered in this field, the default name for your device will be used.)

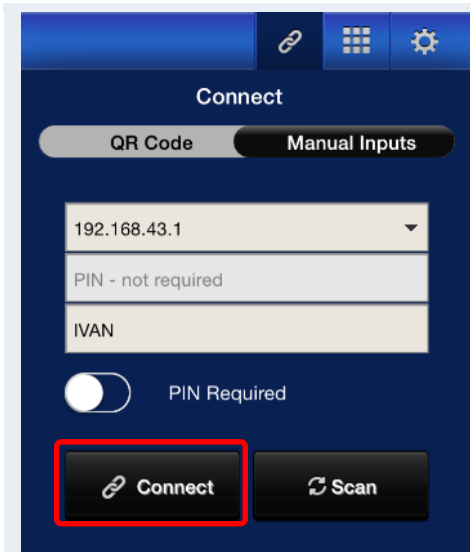

Make Connection:

Tap the **Connect** button. If you are the first *participant*, this will start a presentation group on your NovoPRO. If you are not the first *participant*, you will be joining a presentation group.

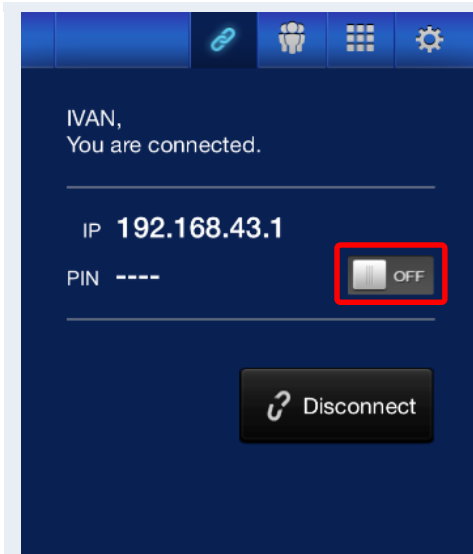

Confirm Connection:

After your *NovoPresenter* app on your iPad connects successfully to your NovoPRO, you will see the connection tab light up blue .

If you are the first *participant*, you will see that your iPad's on-screen display is wirelessly mirrored on your projector or TV display. You can slide the PIN requirement switch to **OFF** or **ON** to disable or enable usage of a PIN code.

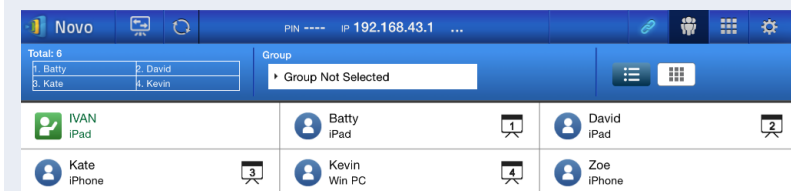

View participants list:

You can tap the  tab to see the current participant list.

Example: There are a total of six *participants* in the presentation group shown at left. The *moderator*, Ivan, is not making a presentation at the moment because he has assigned Kevin, Batty, David, and Kate to be the four *presenters*.

3.2.2 Step 2: Make a presentation

Once you have started/joined a presentation group, you can make a presentation with the contents stored on your iPad, local network, or the Internet. There are four tabs on the lower left corner of the *NovoPresenter* home screen:



Tap this tab to create and share screen notes.



Tap this tab to present an image stored on your iPad.



Tap this tab to present a document stored on your iPad.



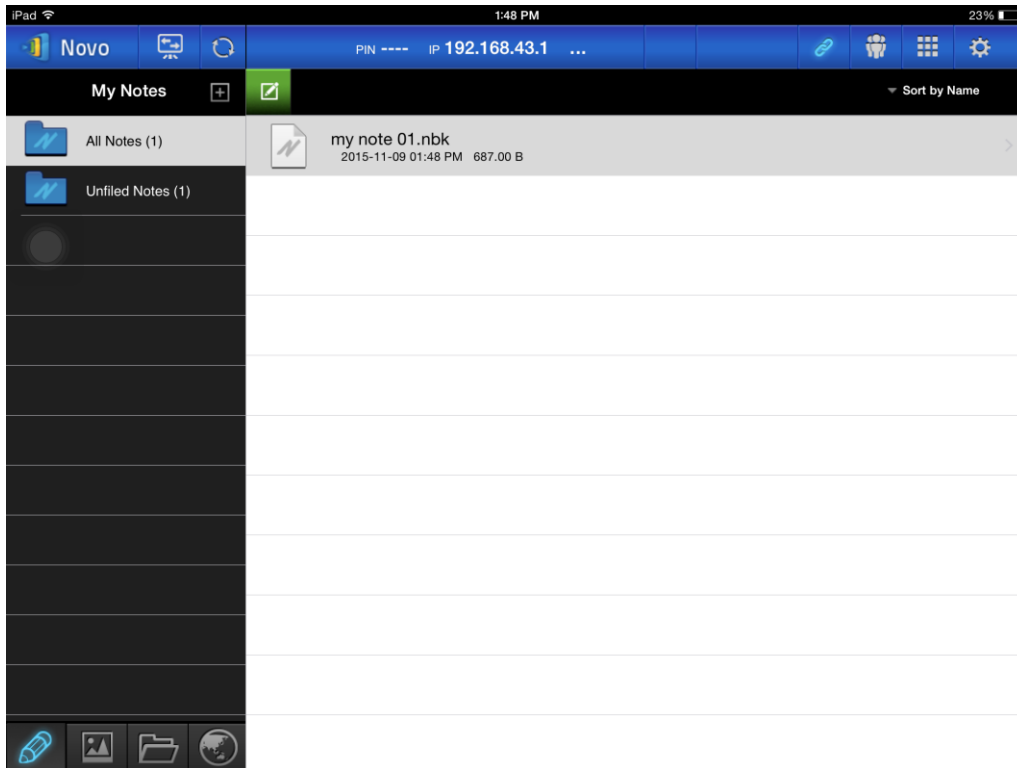

Tap this tab to present a Web page.

3.2.2.1 My Note (Education Edition only)

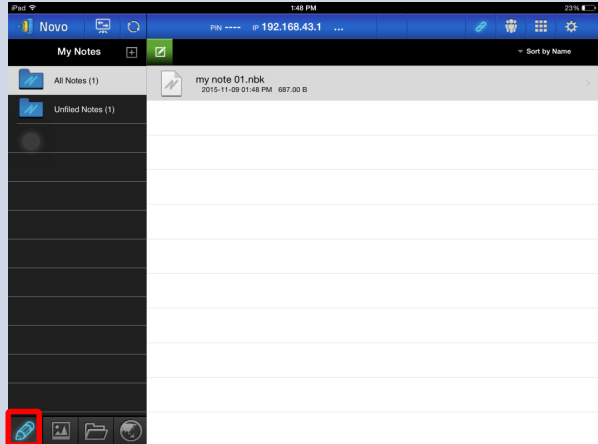

Create and share custom screen notes

This NovoPresenter feature is a virtual whiteboard that allows tablet users to create, manage and display notes in a NovoPRO session.

Function	Description
	<p>Launch My Note: Tap  on the lower left corner of the screen.</p>

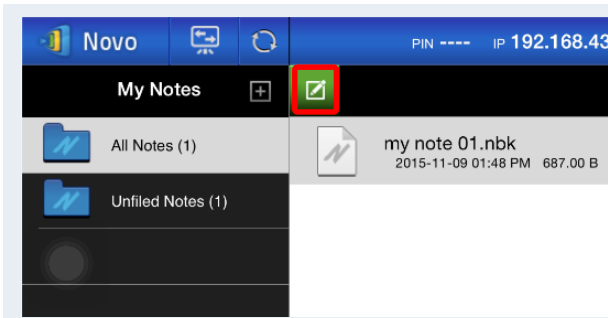

Create a new note presentation:

Tap  on the top of the screen.

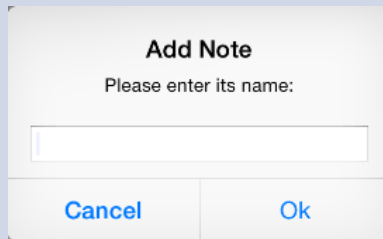

Enter your note name:

Type a name for your note in the “Add Note” dialog box and tap **Yes**.

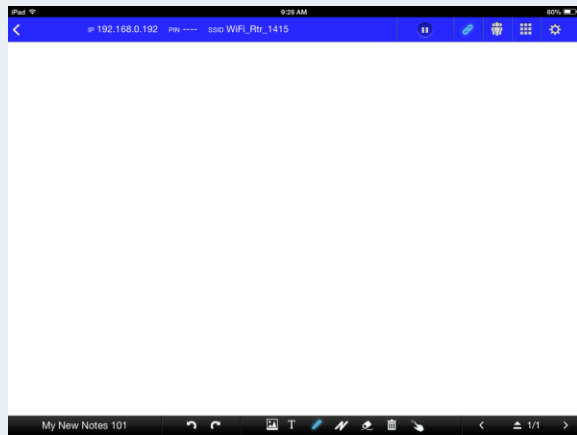





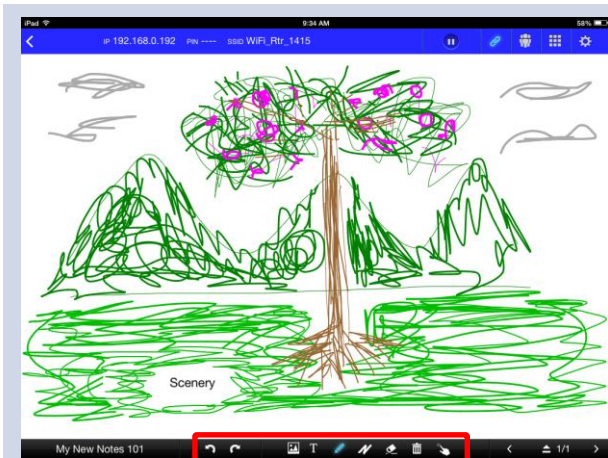



Start making a note:

Your blank note will now open on your screen.



Use the note tools:





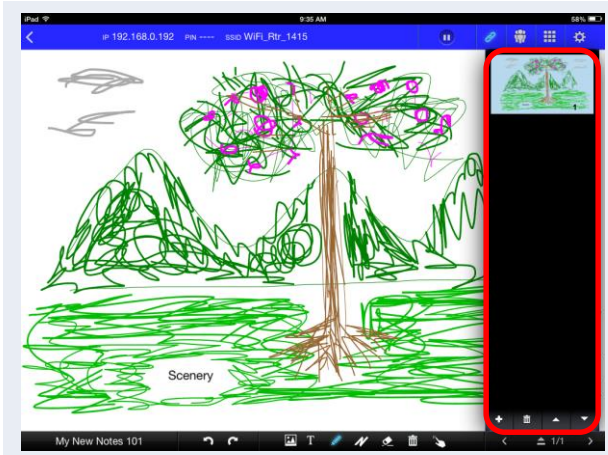

The note tools are located on the bottom of the screen. Tap an icon for the desired function.

-  Insert a picture stored on your Android tablet.
-  Type texts onto the screen. You can reposition your text by dragging it across your screen with your finger.
-  Draw on the screen .
-  Mark or highlight something on screen.
-  Erase texts, drawings, or highlights.
-  Clear changes without saving.
Note: This is one of the two trash can icons visible on the My Notes screen. The clear icon is on a solid black background in the lower middle of the screen.
-  Move an image to another location. Tap this button and drag the image to its new position.
-  Undo a change.
-  Redo a change.



Add additional pages to My Notes presentation:

The page management tools are located in the add-page options pane on the right side of the screen.

-  Open the add-page options pane.
-  Close the add-page options pane.
-  Add a new page.
-  Select a page by tapping its thumbnail.
-  Delete the selected page.
Note: This is one of two trash can icons visible on the My Notes screen. The delete page icon is on a dark grey background in the lower right side of the screen.
-  Move the selected page up.
-  Move the selected page down.



Close and save changes:

Tap  to close and save your changes to your note file.

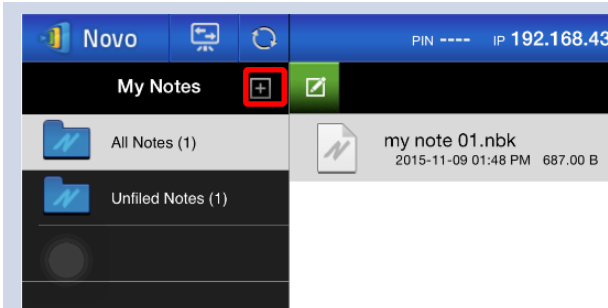

Organize your notes with Subject folders

Tap this icon to add a new subject folder. When the “Add Subject” dialog box appears, enter the name for the new subject folder.

When the “Add a Subject” dialog box pops up, enter the name for the new subject folder.

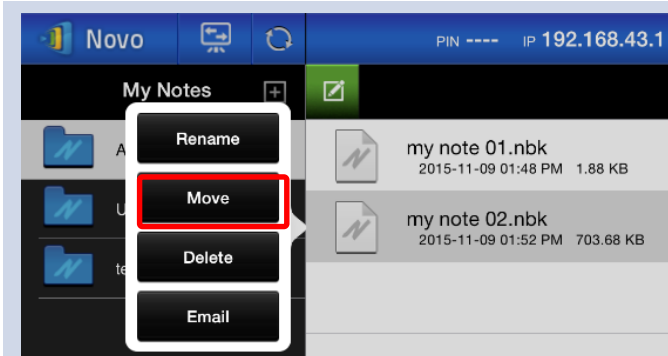

To move a note to a new subject folder, tap the file to select it. When the function bar appears, tap  button.

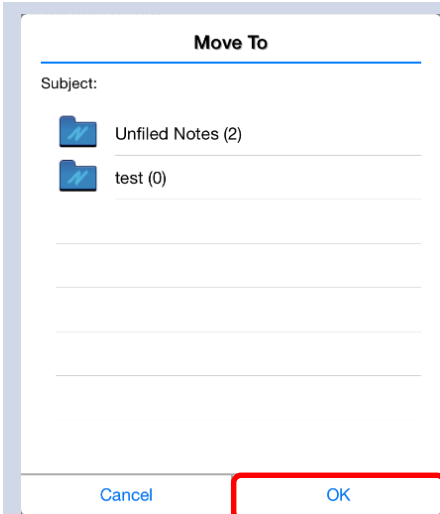

When the “Move to” window pops up, select a folder and then tap “Ok”.

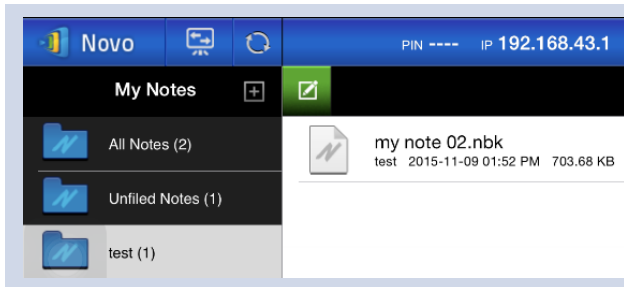

The chosen file has been moved to the selected folder.

3.2.2.2 Presenting an image

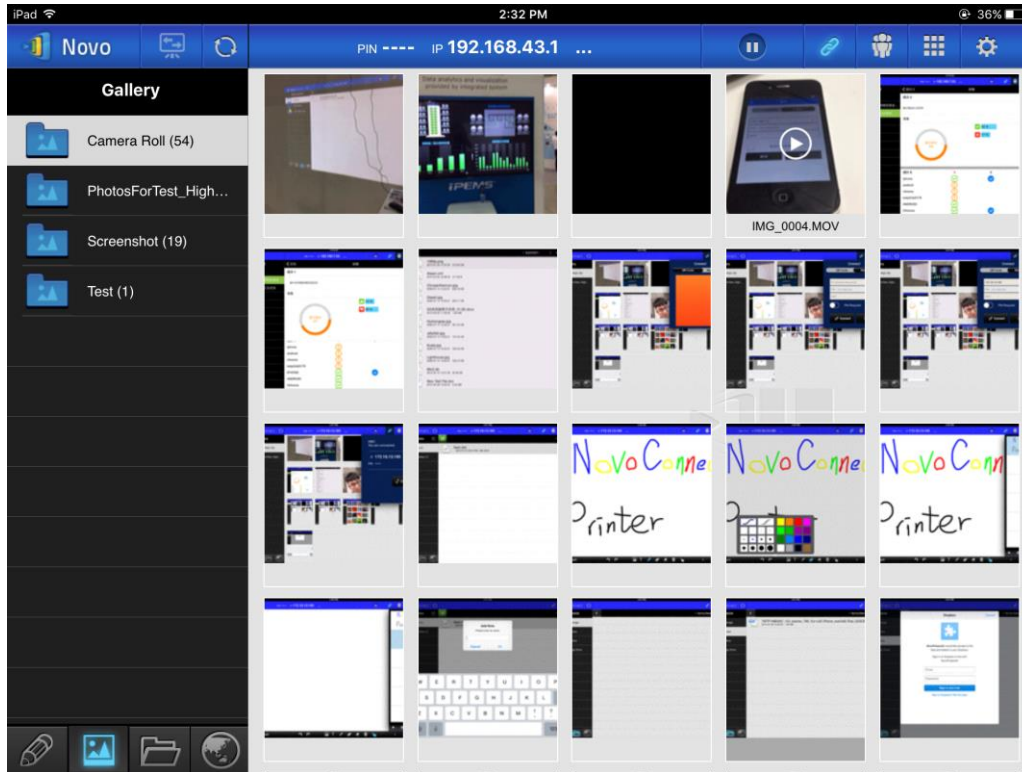

To import presentation files to an iPad, please refer to the iPad user manual. A sample iTunes screen is presented in the diagram below.

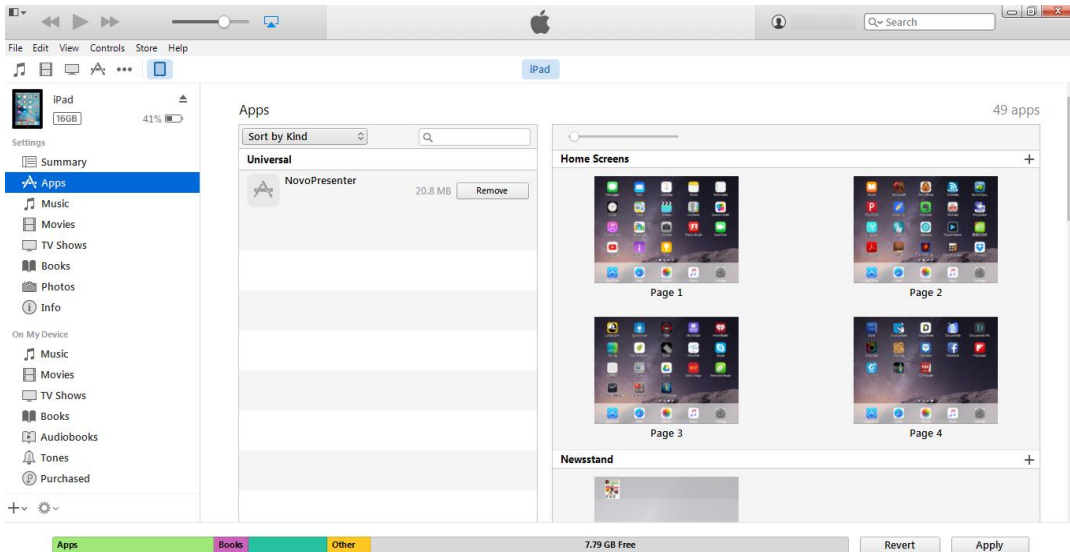

File Sharing

The apps listed below can transfer documents between your iPad and this computer.

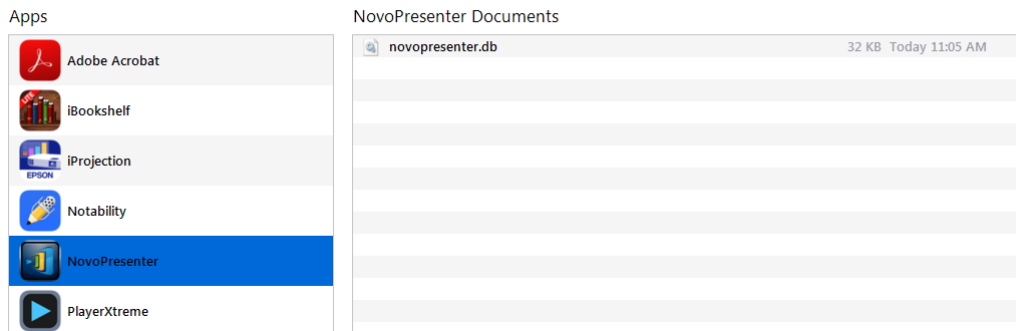



Function	Description
	<p>Import: Please refer to the iTunes user manual for the procedure for importing images to your iPad for presentation.</p> <p>Navigation: Tap the  tab to access folders with image files. The image symbol will light up blue. Navigate to a folder by tapping on the desired folder icon. Tap the return tab  to return to previous folder.</p>



Image thumbnails:

You will see thumbnails of your image files displayed once you navigate to a folder containing the images. You can select a thumbnail to view the full image.

Example: Tap on a logo image thumbnail.





Note: Tap the  tab at any time to return to the previous folder. Tap the  tab at any time to refresh the screen.



Image presentation:

The selected image will be displayed in full screen. You can zoom in on the image by sliding two fingers apart (what Apple refers to as the “pinch open” gesture), or you can zoom out of the image by sliding two fingers toward each other (“pinch close”).

If you have more than one image in the same folder, you can swipe your finger left or right across the screen to advance to the next or previous image.

To return to the *Image Thumbnails* page, tap the  tab. To use the on-screen annotation tools, tap the  tab.

3.2.2.3 Presenting a document (local storage)

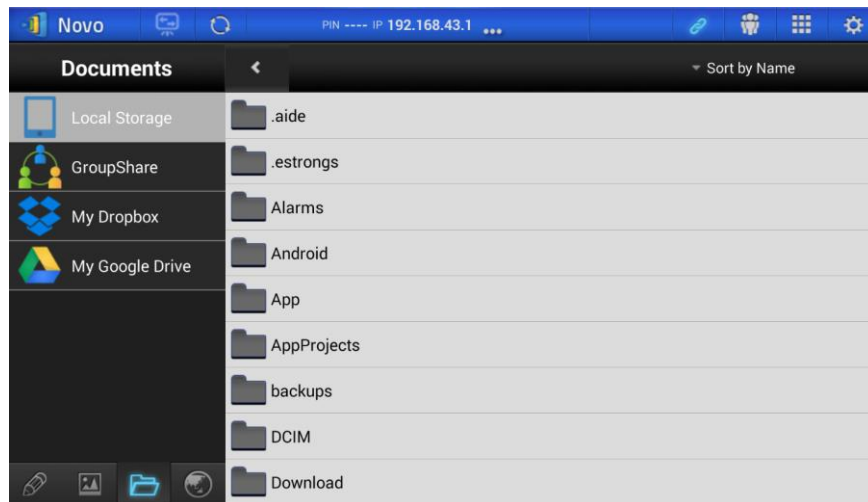

Function	Description
----------	-------------

Import:
Using the iTunes software, import the desired presentation documents to your iPad.

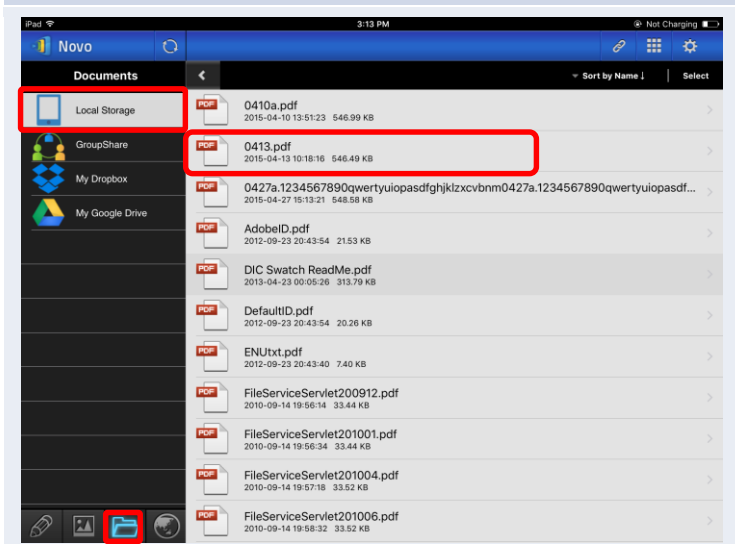

Navigation:
Tap tab to access folders with presentation files. The folder image will light up blue. If locally stored content is not displayed, tap tab.
Navigate to a folder by tapping the desired folder. The document list will display documents that are supported by *NovoPresenter*. Locate and tap the desired document.
Example: Tap the document “0413.pdf”.



If you wish to sort the folder list into a desired order, tap the **Sort by...** tab on the drop-down menu, then select one of the following options:

- Sort by Name (default)
- Sort by Date
- Sort by Extension

Example: Tap the **Sort by...** drop-down menu. Select the option *Sort by Date* by tapping the **Sort by Date** button.

Note: You can tap the tab at any time to refresh the screen contents.





Document presentation:
The selected document will be displayed in full screen. You can zoom in on the document by sliding two fingers apart (pinch open), or you can zoom out on the document by sliding two fingers toward each other (pinch close).
To scroll down or move to the next page, slide your finger up or drag the scroll bar down. To scroll up or move to the previous page, slide your finger down or drag the scroll bar up.

To return to the *Document List* page, tap tab. To use the on-screen annotation tools, tap tab.

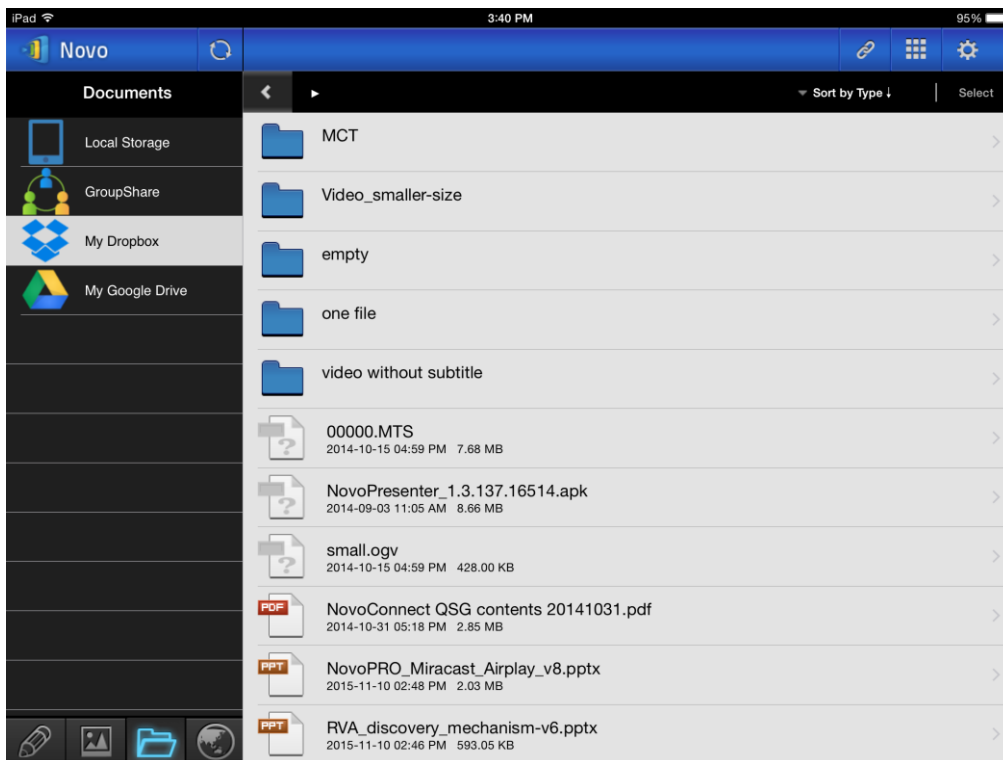
3.2.2.4 Presenting a document (with Dropbox)

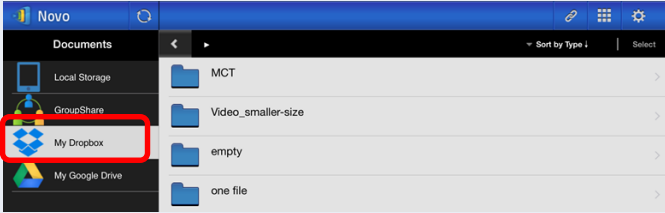

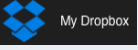
Function	Description
	<p>Set your NovoPRO to WiFi Mode: Set your NovoPRO's Wi-Fi mode to WiFi Mode and connect to a Wi-Fi AP router with Internet access.</p>
	<p>Select Dropbox as the document source: Tap the folder tab . It will light up blue. Tap the  My Dropbox tab.</p>

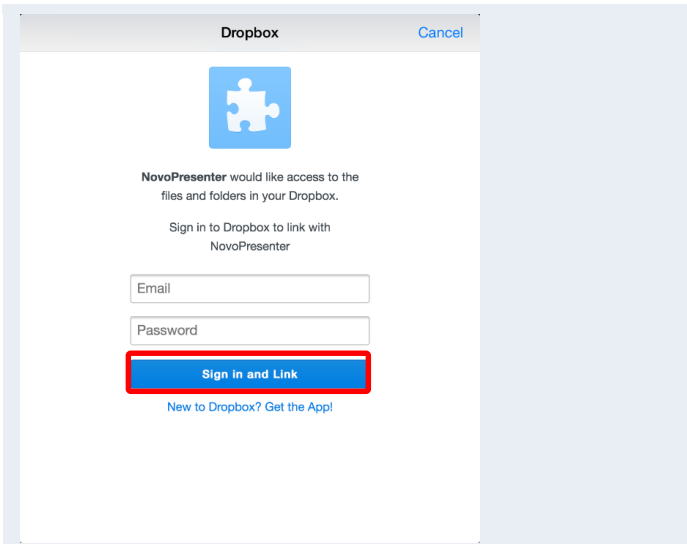

First time using Dropbox in NovoPresenter:

When using the *NovoPresenter* Dropbox feature for the first time, a link between *NovoPresenter* and your Dropbox account will need to be established.

Enter the e-mail address associated with your Dropbox account in the *Email* field and the associated password in the *Password* field, and then tap the **Sign In** button.

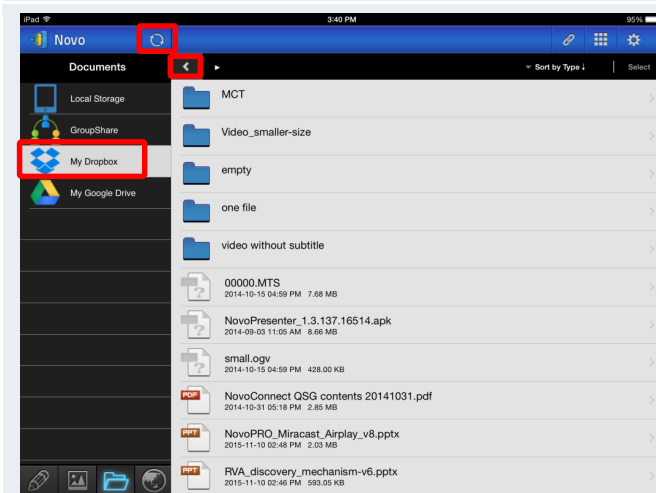

Navigation:



By default, your Dropbox's home directory contents will be displayed first. Navigate to a folder by tapping the desired folder.

If you wish to sort the list into a desired order, tap the **Sort by...** drop-down menu then select one of the following options:

- Sort by Name
- Sort by Date (default)
- Sort by Extension

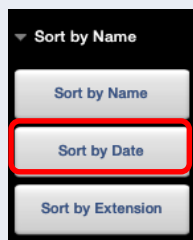
Example: Tap the **Sort by...** drop-down menu. Tap the option *Sort by Name*, and then tap the *Documents* folder.



Note: You can tap the  tab at any time to return to previous folder. You can also tap the  tab at any time to refresh the Dropbox list (you will be returned to your Dropbox list's home directory). You can tap the  tab at any time to refresh the screen contents.

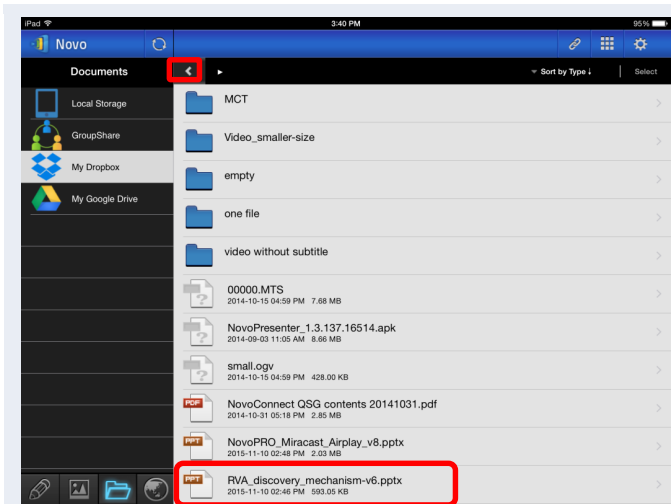

Document list:

Once you locate the desired document, you can open and present the document page by page from the Dropbox Web site without having to download the document to your iPad.

Example: Tap the document “RVA_discovery_mechanism-v6.pptx”.

Note: You can tap the ◀ tab at any time to return to the previous folder.

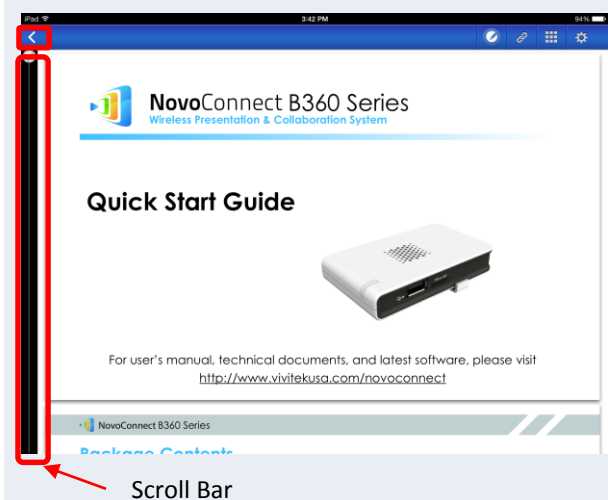

Document presentation:

The selected document will be displayed in full screen.

If your presentation is paused, tap the ▶ button to resume the presentation. You can zoom in on the document by sliding two fingers apart (pinch open), or you can zoom out on the document by sliding two fingers toward each other (pinch close).

To scroll down or move to the next page, slide your finger up or drag the scroll bar down. To scroll up or move to the previous page, slide your finger down or drag the scroll bar up.

To return to the *Document List* page, tap the ◀ tab.

To use the on-screen annotation tools, tap the 📝 tab.

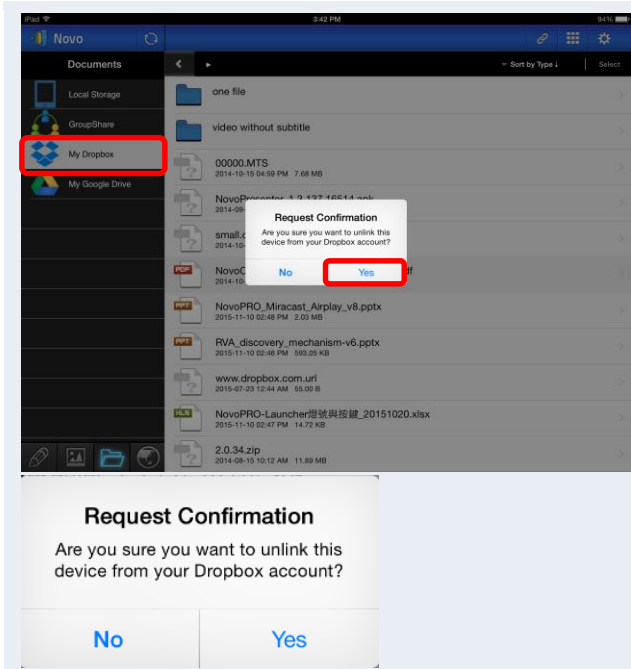

Unlink Device from Dropbox:

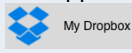
If you need to unlink the *NovoPresenter* app from your Dropbox account, tap and hold the  tab for a few seconds. When the *Request Confirmation* appears, tap **Yes** to proceed.

3.2.2.5 Presenting with a browser

To include a browser in your presentation, please follow the steps listed in the table below. For reference, a sample screen is also shown below.

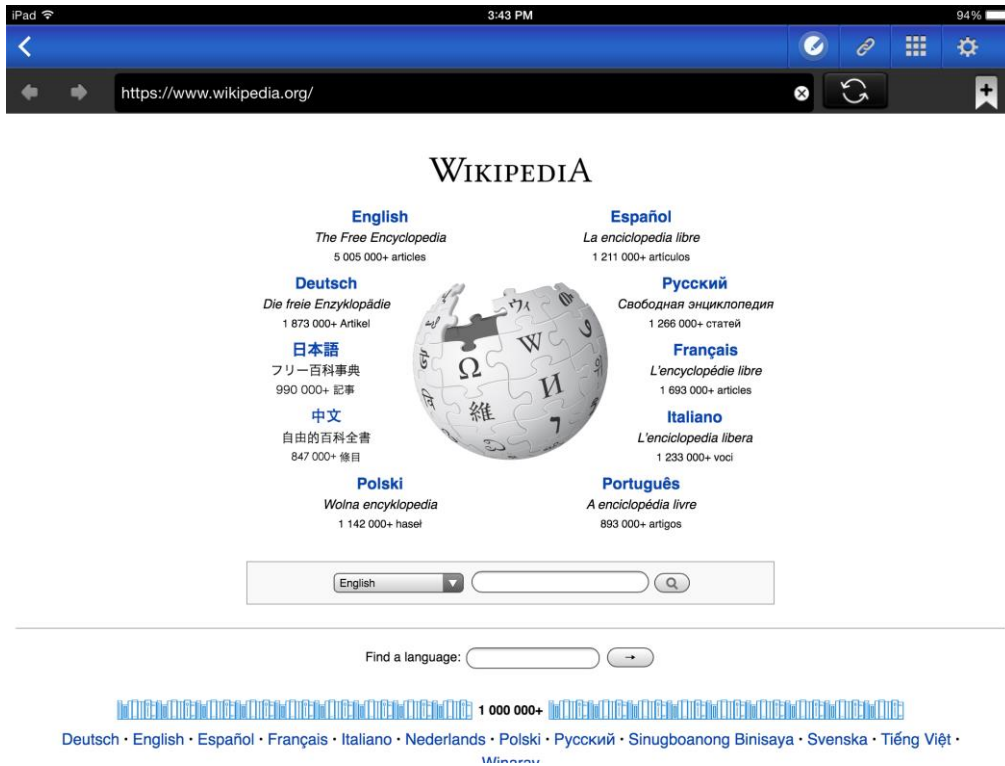

(Note: For Education Edition all participants will automatically allow screen preview.)

Function	Description
	<p>Set your NovoRO to WiFi Mode: Set your NovoPRO's Wi-Fi mode to WiFi Mode and connect to a router with Internet access. Please refer to the <i>Remote Viewer</i> chapter for more details.</p>

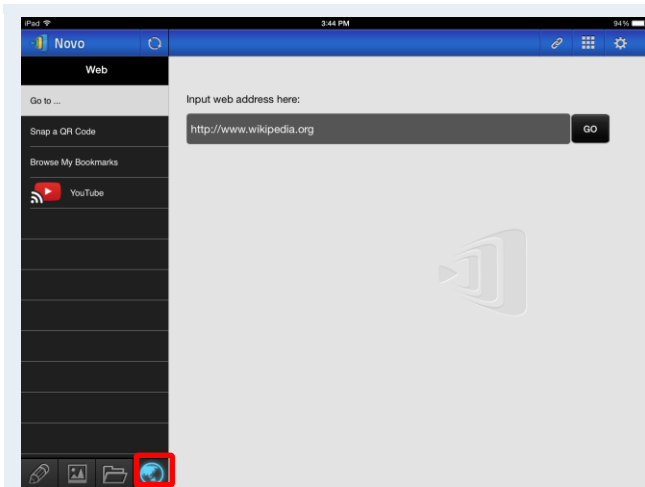

Start browsing for a Web page:

Tap the internet tab . It will light up blue. Select one of the three options to access a Web page:

- Go to... (enter URL address[default])
- Snap a QR Code
- Browse My Bookmarks (Web site bookmarks)

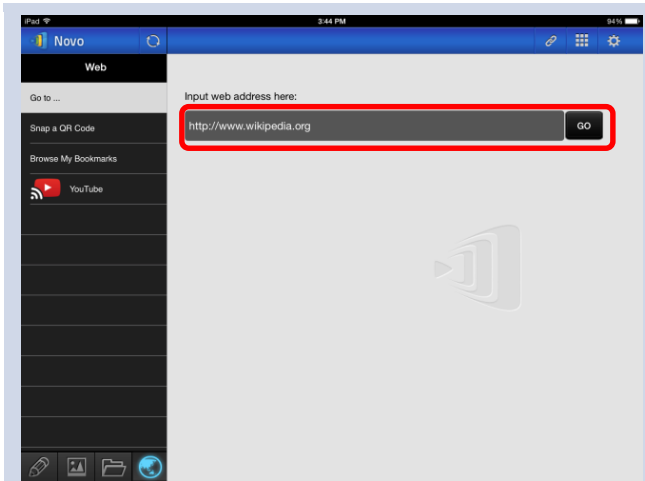

Go to...:

Tap the **Go to...** tab. Enter the Web page URL and tap **Go**. Example: Enter the URL www.wikipedia.org and tap **Go** (the pre-fix <http://> can be omitted).

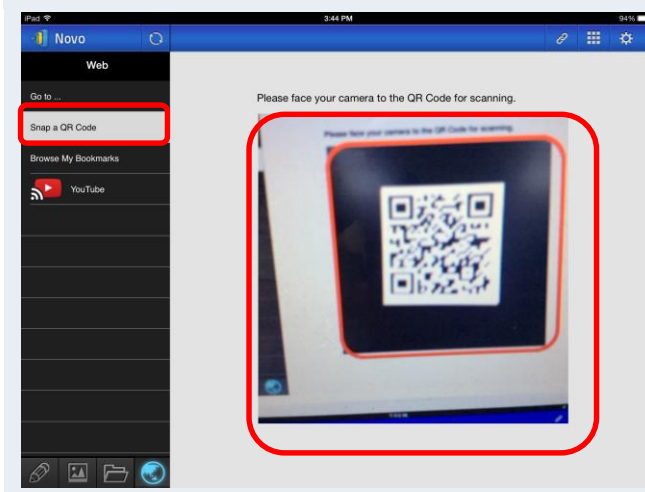

Snap QR code:

Tap the **Snap QR Code** tab. Aim your iPad's camera at a QR code containing Web page information. *NovoPresenter* will detect the URL and access the corresponding Web page.

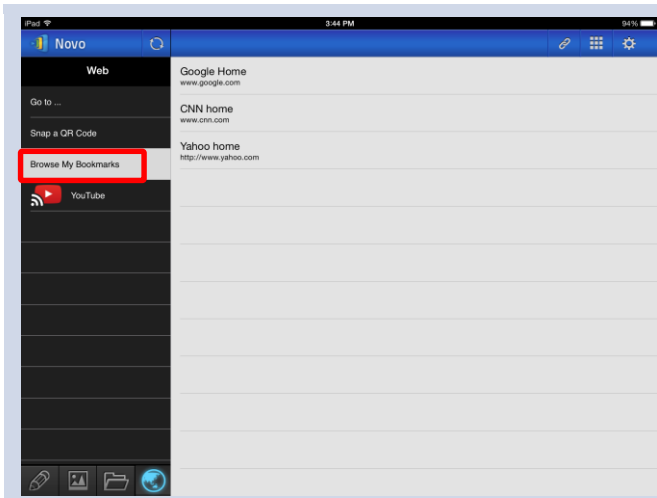

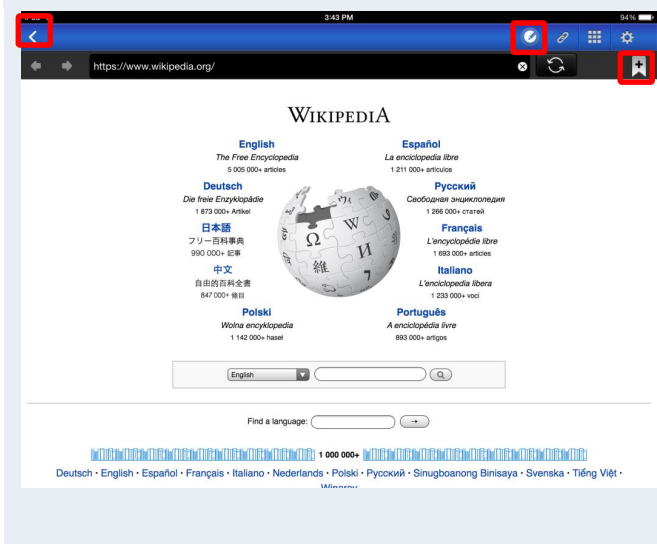

Browse my Bookmarks:

Tap the **Browse my Bookmarks** tab.
 From the bookmark list, tap the bookmark of interest to go to its corresponding Web page.
 Touch and hold a bookmark for two seconds to edit or delete the bookmark.
 Note: The bookmark list may initially be empty. You can add a Web page to the bookmark list at any time while browsing and presenting Web pages.





Web page presentation:









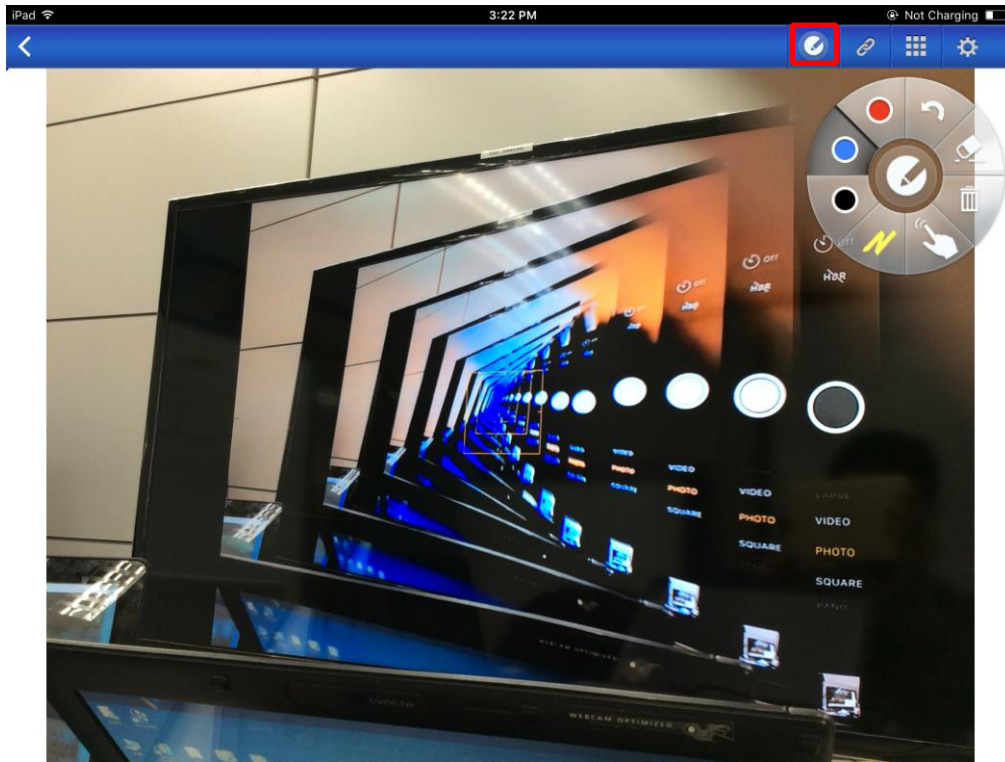

The selected Web page is fully displayed. You can zoom in on the Web page by sliding two fingers apart (pinch open), or you can zoom out of the Web page by sliding two fingers toward each other (pinch close).
 To scroll down or move to the next page, slide your finger up. To scroll up or move to the previous page, slide your finger down.
 To add this Web page to the bookmark list, tap the  tab.
 To return to the *Web menu page*, tap the  tab. To use the on-screen annotation tools, tap the  tab.

3.2.2.6 Annotation

Sometimes you may want to write, highlight, or mark portions of your presentation materials directly on the tablet screen. *NovoPresenter* provides an on-screen annotation tool for the *presenter* to annotate the presentation material directly without changing the original. You can

enable the annotation tool  by toggling the  tab on, as shown in the screenshot below.





Function	Description
	<p>Tap the  tab to enable the annotation tool.</p> <ul style="list-style-type: none">  Annotate with a red marker  Annotate with a blue marker  Annotate with a black marker  Annotate with a yellow highlighter  Change from annotation (writing) mode to touch panel (operation) mode  Trash can  Eraser  Undo

3.2.2.7 Screenshot and share

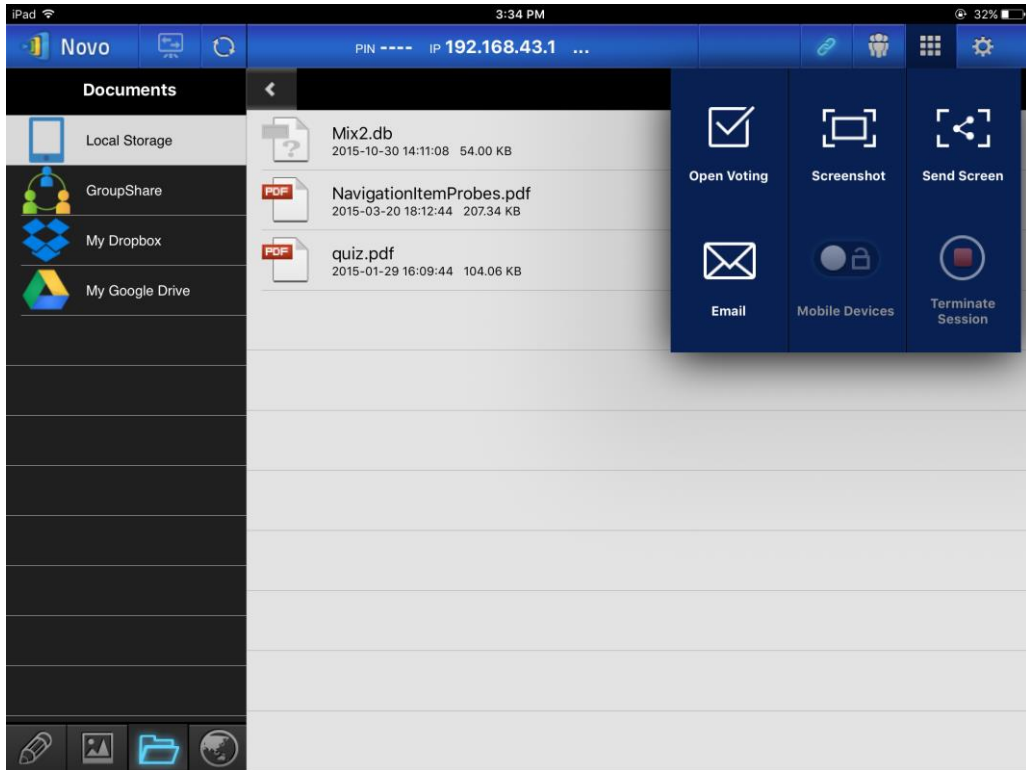
This feature allows users to take screenshots of the display and share it with other users.

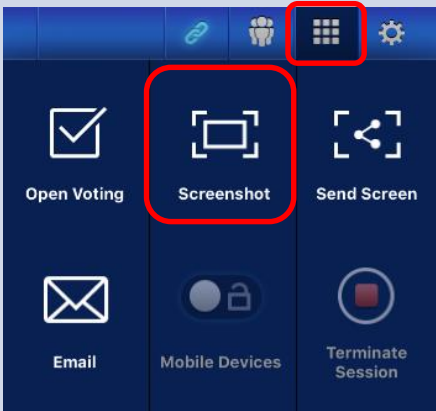

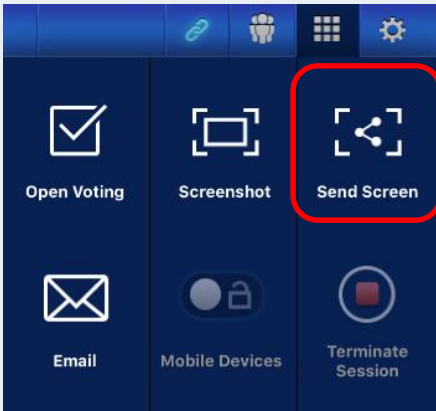
Function	Description
	<p>To take a screenshot:</p> <p>Tap the  tab and tap the Screenshot area. A file directory will be displayed for the location of the saved screenshot.</p>
	<p>To share a screenshot:</p> <p>Tap the Send Screen button, it will send a screenshot to other users.</p>

3.2.3 Step 3: Presentation management

Once you have started or joined a presentation group, you are ready to make a presentation and collaborate with other *participants*. A sample screen view is provided below.

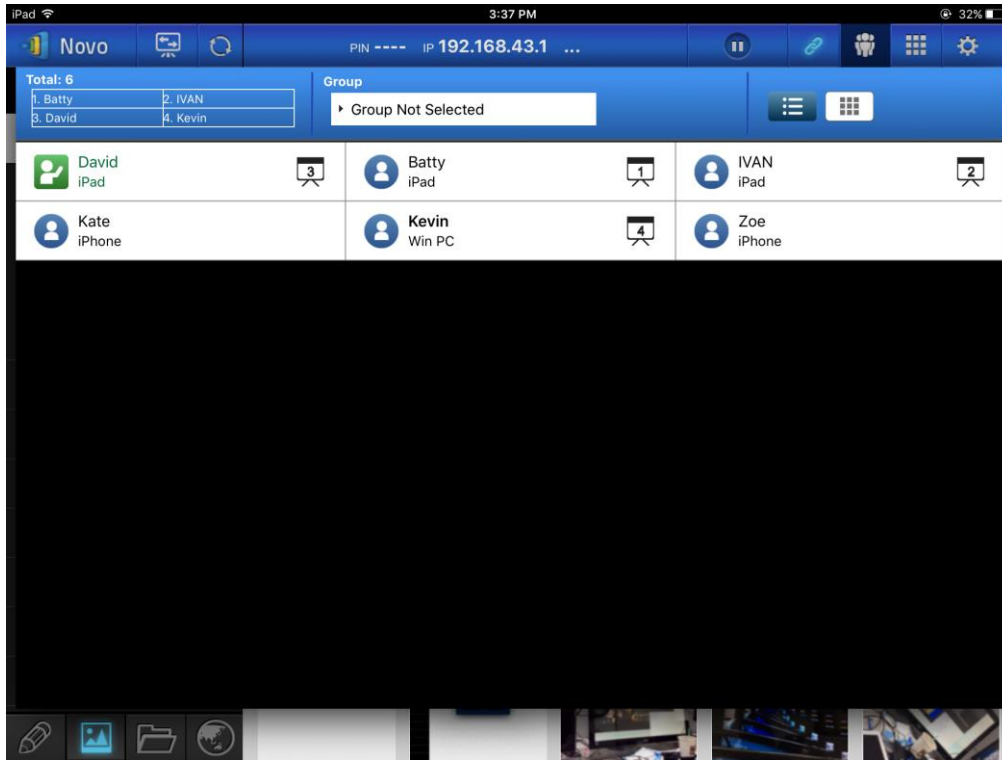

3.2.3.1 Set Moderator mode (*Corporate Edition only*)

When moderator mode is set on, the moderator can manage presentations or make a presentation in the split screen.

Function	Description
	<p>Set the moderator mode:</p> <p>Tap the tab and tap the Moderator On/Off switch to set the moderator mode.</p> <p> OFF The moderator mode is off.</p> <p> ON The moderator mode is on.</p>

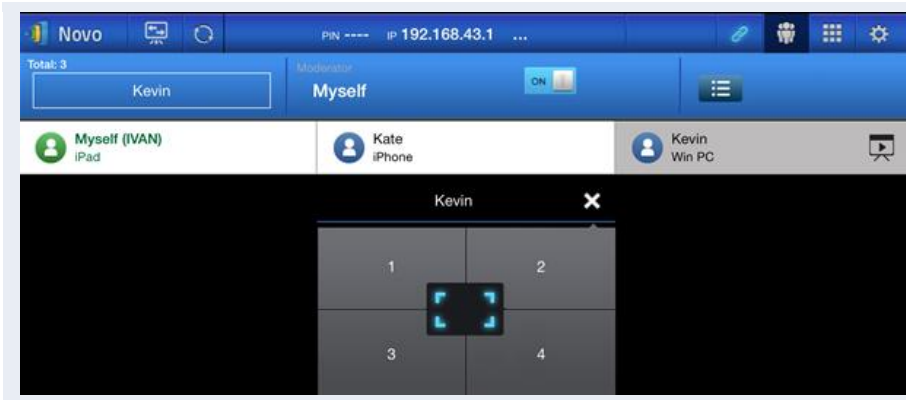





Manage presentations or make a presentation:
The moderator now has the authority to manage presentations or make a presentation in split screen.

3.2.3.2 Role assignment

There are three roles in a presentation group, the *moderator*, the *presenter*, and the *participant*. The first person to start a presentation group with a NovoPRO is assigned the *moderator* role. Subsequent joiners are assigned the *participant* role. The *moderator* is defaulted to assume the *presenter* role until he hands over the *presenter* role to another *participant*.

To show all current *participants* who have joined the presentation group, please tap the  tab.

(Note: For Education Edition all participants will automatically allow screen preview.)

Function	Description
	<p>Select the  tab to show the <i>participant</i> list.</p> <p> indicates the current <i>moderator</i>.</p> <p> indicates the current <i>presenter</i>.</p> <p> indicates the current <i>presenter</i> that is presenting in the indicated split-screen box number (#1-4).The instance here shows a <i>presenter</i> that is presenting in Box #1.</p> <p>Example: There are six <i>participants</i> in the presentation group – three with iPads, one with Windows PC, one with an Android phone, and one with an iPhone. Kate, Batty, David, and Kevin are <i>presenters</i> currently presenting in boxes #1-4 of the four-way split screen (which will be explained in detail later).</p>

* For the Education Edition all participants will automatically allow screen preview.

Example 1:



Indicates the names of the *presenters* seen by other *participants* and the total number of current *participants*.

Example 1: Ivan is the only *presenter*, and there are currently 2 *participants*.

Example 2:



Example 2: Kevin, Kate, Batty, and David are 4 *presenters*, and there are currently 6 *participants*.

3.2.3.3 Role change, screen preview, and four-way split screen

(Note: For Education Edition all participants will automatically allow screen preview.)

Function	Description
	<p>Role change: change a participant to a moderator</p> <p>First select the tab to show the <i>participant</i> list. Then tap one participant's icon, whom you want to transfer <i>moderator</i> role to.</p> <p><i>Please note: only the moderator is allowed for this operation.</i></p>
<p>On moderator's screen:</p>	<p>A dialog box pops up to ask for your confirmation. You have 20+ seconds to tap the Yes button to accept or tap the No button to reject the requested role change.</p>
<p>On participant's screen:</p>	<p>At the same time, a dialog box will appear on the <i>participant's</i> screen to ask his/her confirmation. The <i>participant</i> has 20+ seconds to tap the Yes button to become the new <i>moderator</i> or tap the No button to reject assignment.</p>

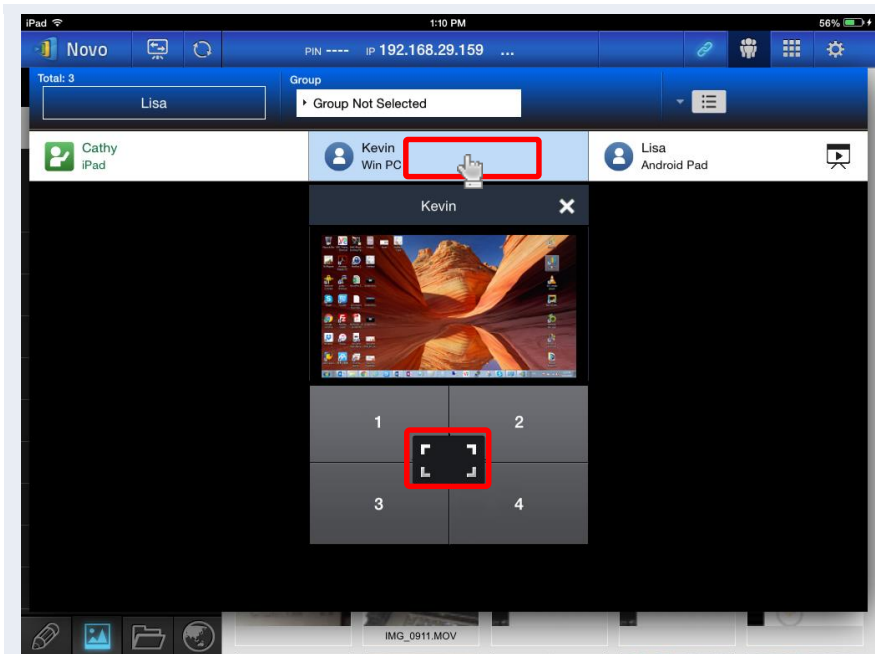

Role change: change to be a sole presenter

Highlight *participant* Kevin by tapping the middle part of Kevin's entry.

Tap the  icon of the split screen selection area to request Kevin to be the sole *presenter*.

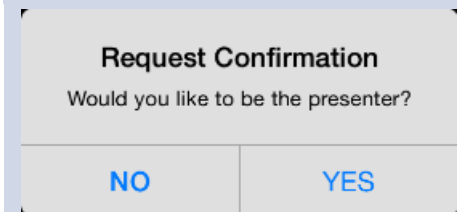

When a *participant* is asked to be a *presenter*, a dialog box will appear on the *participant's* screen. The *participant* has 20+ seconds to tap the **Yes** button to become the new *presenter* or tap the **No** button to reject assignment.

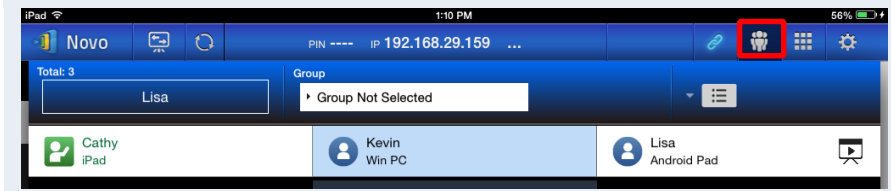

To perform screen preview (Education Edition only):

Tap the  tab to show the *participant* list. For the *Education Edition*, all participants will automatically allow screen preview.

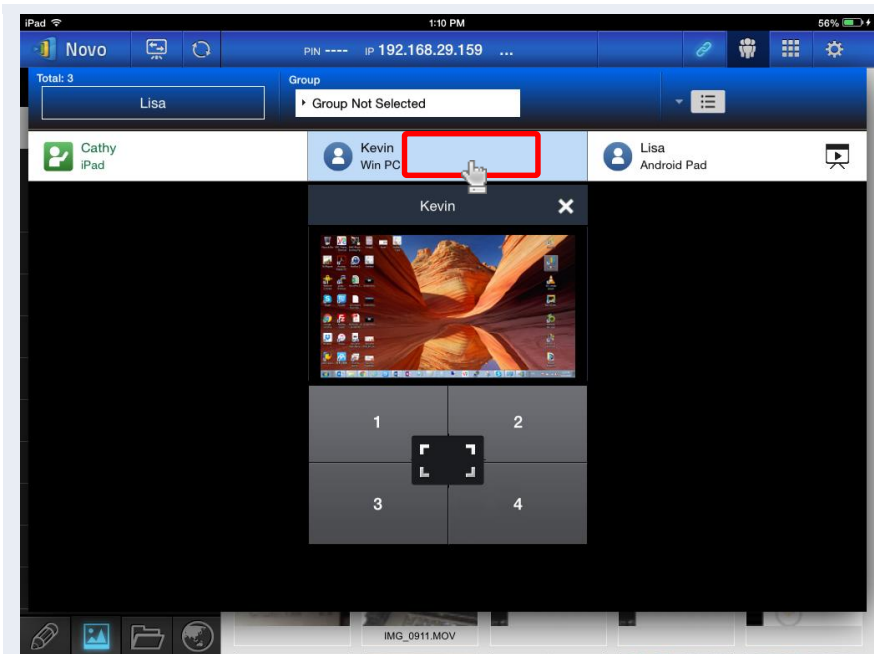

To preview a *participant's* screen, tap the middle part of an entry. Wait for a few seconds for the screen to be sampled and displayed. In this example, Kevin's Windows PC is selected to be previewed.

Tap the middle part of that's participant's entry again to close screen preview.

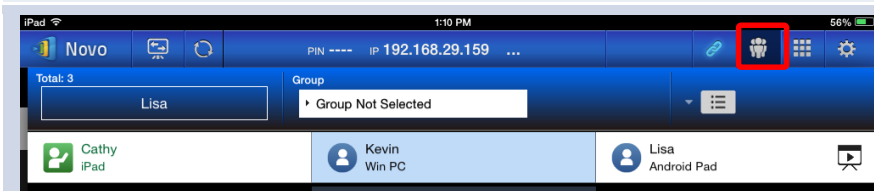

To perform a four-way split screen presentation:

Tap the  tab to show the *participant* list.

Select a *participant* to make a presentation. In this example, Kevin has been selected.

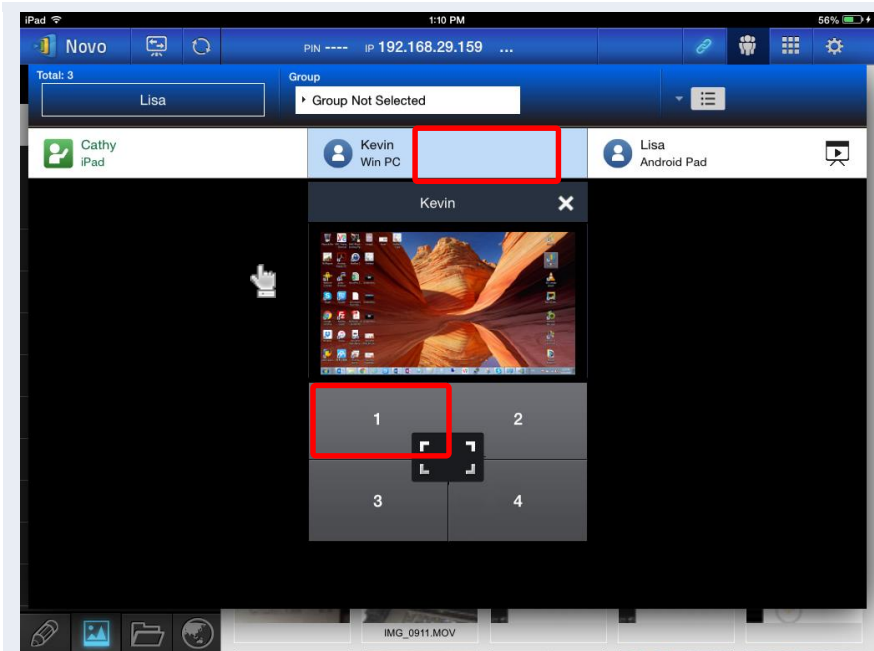

Tap the middle part of Kevin's entry to bring up screen preview. Then tap one of the four boxes (#1-4) in the split screen selection area to assign Kevin to perform a presentation on one of the four boxes of the four-way split screen.

In this example, Kevin is assigned to make a presentation in Box #1.

Request Confirmation

Would you like to be the presenter?





NO

YES

Kevin will receive a request to perform a presentation on one of the four boxes of the four-way split screen.

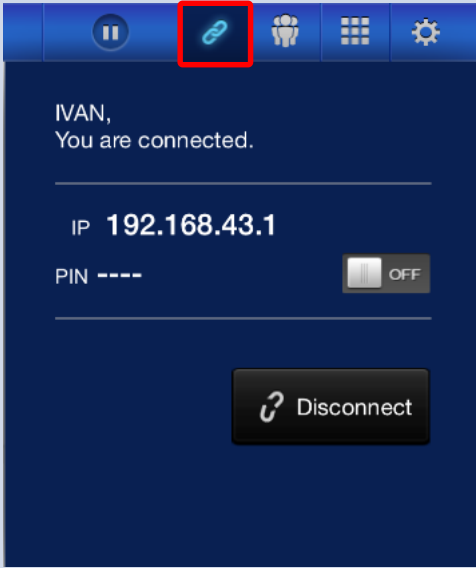
After Kevin accepts (within 20+ seconds) being one of the four possible *presenters* (by tapping the **Yes** button), Kevin's screen will appear in one of the four boxes of the four-way split screen.

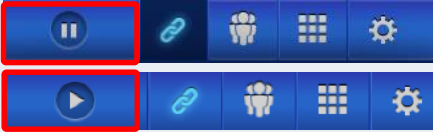
3.2.3.4 Pause, resume, and disconnect

Function	Description
	<p>To pause a presentation:</p> <p>Tap the  tab to enter the presentation control page.</p>
	<p>Pausing and resuming a presentation:</p> <p>While presenting, the <i>presenter</i> can toggle between  and  to pause and resume the presentation respectively.</p>

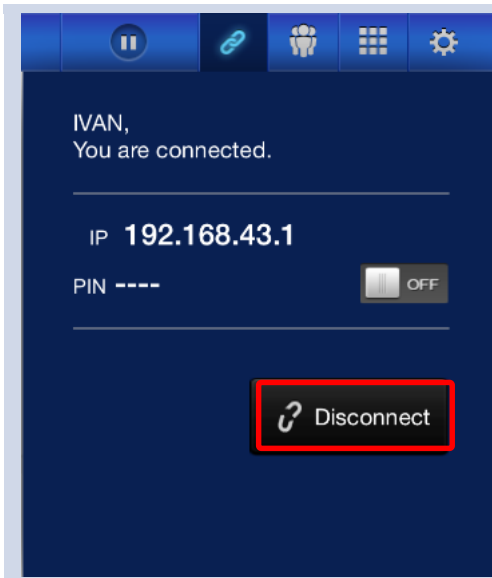



To disconnect from a presentation group:

Tap **Disconnect** button to exit the presentation group.

If the *moderator* exits the presentation session without handing over the *moderator* role, all *participants* will receive a message prompting them to take over moderator role. The first to respond to the prompt will assume the role of *moderator*.

3.2.3.5 Reset

Occasionally you may encounter problems with the network or the computer causing the presentation group to malfunction on your NovoPRO. One way to resolve this problem is to reset the presentation group.

Function	Description
<p>A screenshot of the "Settings" application. The top navigation bar has a gear icon highlighted with a red box. Below the title "Settings", there are sections for "Local Settings" and "Remote Device". Under "Remote Device", the "Device's Reset" option is highlighted with a red box. The footer text reads "© 2013 Delta Electronics, Inc. All right reserved."</p>	<p>To perform a reset:</p> <p>First tap  tab and tap  arrow of the Device's Reset window.</p>

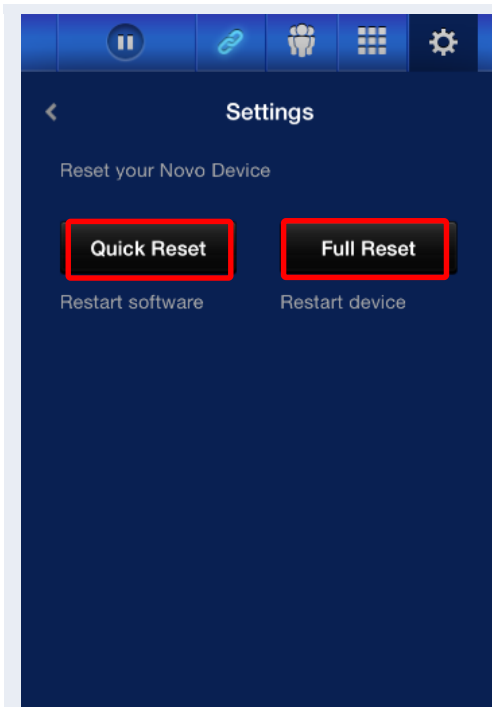

Resetting:

Tap the **Quick Reset** to reset the presentation group to allow a presentation group to start over again.



Tap the **Full Reset** button to reset the NovoPRO device. The NovoPRO device will restart automatically.

Conflicts may occur when multiple *participants* simultaneously attempt to reset the presentation group or the NovoPRO. The reset privilege priorities are as follows:

1. *Moderator*: The *moderator* has the sole privilege to quick-reset the presentation group or the NovoPRO device when the *moderator* stays connected to the NovoPRO.
2. *Presenter*: If the *moderator* lost connection with the NovoPRO, the current *presenter* inherits the privilege to quick-reset the NovoPRO.
3. *Participant*: If the *moderator* and the *presenter* both lost connection with the NovoPRO, any *participant* can quick-reset the presentation group.



3.2.3.6 Lock/Unlock students' tablets (Education Edition only)

This feature for PCs and tablets allows teachers to lock down student tablets. This feature is only available in the *Education Edition*.

Function	Description
	<p>To lock/unlock students' tablets:</p> <p>Click the  tab to bring up the toolbar page, then click Mobile Devices to lock or unlock the students' tablets.</p> <p> Student tablets are unlocked.</p> <p> Student tablets are locked.</p>
	<p>Student tablets locked:</p> <p>A lock icon will pop up on the students' tablets to show that the screen has been locked.</p>

3.2.3.7 Terminate session (*Education Edition only*)

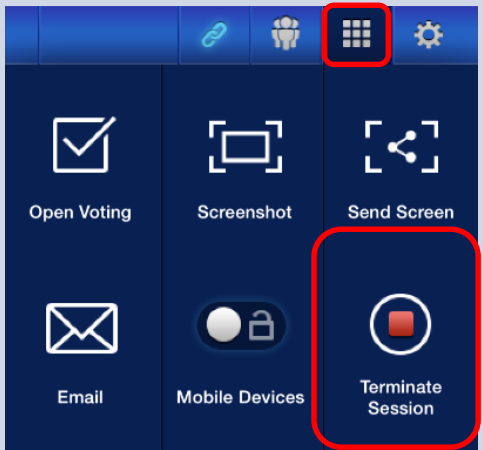
Here you can disconnect all devices with the touch of one button.

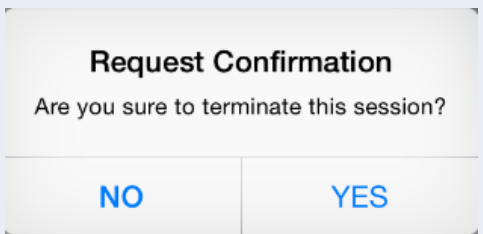
Function	Description
	<p>To terminate a session: Tap the  tab and tap Terminate Session.</p>
	<p>Confirmation: Click Yes to terminate the session. All devices will be disconnected.</p>

3.3 Presenting with Android tablet

The Android version of the *NovoPresenter* app (pictured in the image below) enables an Android tablet device to connect to the NovoPRO and make a presentation.



Launch Presentation Application

Launch the *NovoPresenter* application by selecting the *NovoPresenter* app icon  on your Android tablet. The *NovoPresenter* app will be launched.

To make a presentation, follow the steps below:

Step 1: Connect to your NovoPRO device

Step 2: Make a presentation

Step 3: Manage the presentation

3.3.1 Step 1: Connect to your NOVOPRO device

There are two ways to connect to your NovoPRO device:

1. Connect to your NovoPRO device automatically via QR Code.
2. Connect to your NovoPRO device manually.

3.3.1.1 Connect to your NovoPRO device automatically via QR Code

This is the default NovoPRO connection option which allows you to connect to your NovoPRO automatically without any manual configurations. After launching the *NovoPresenter* app, tap the

 tab (as seen in the screenshot below) and access the connection options.

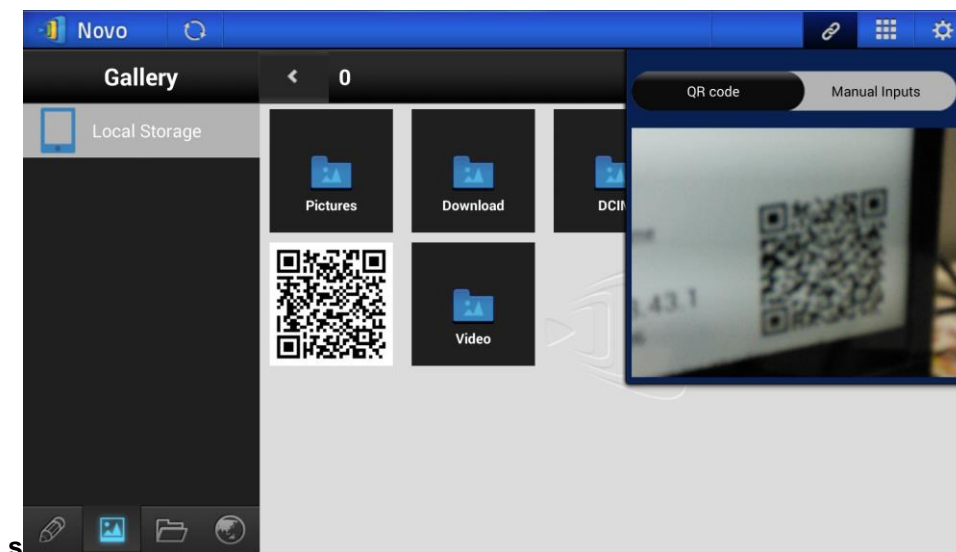

Function	Description
	<p>Connect to the NovoPRO automatically via QR Code:</p> <p>The QR code / Manual inputs switch will be in the QR code position by default (if not, just tap the switch once).</p> <p>Aim your tablet's camera at the QR code containing login information, which can be found on your NovoPRO home screen or on the screen of the device connected to your NovoPRO. Under normal circumstances, <i>NovoPresenter</i> will automatically login to your NovoPRO.</p> <p>Should automatic login fail, follow the manual configuration option in the section 3.3.1.2 Connect to your NovoPRO device manually.</p>
	<p>Confirm Connection:</p> <p>After your <i>NovoPresenter</i> app on your Android tablet is connected successfully to your NovoPRO, you will see the connection tab light up blue .</p> <p>If you are the first <i>participant</i>, you will see that your Android tablet's on-screen display is wirelessly mirrored on your projector or TV. You can slide the PIN requirement switch to OFF or ON to disable or enable usage of a PIN code.</p>
	<p>View participants list:</p> <p>You can tap the  tab to see the current <i>participant</i> list.</p> <p>Example: There are a total of six <i>participants</i> in the presentation group. Thomas is <i>moderator</i>. However, he is not making a presentation at the moment. He has assigned Kevin, Terry, Kate, and Ivan to be the four <i>presenters</i>.</p>
	<p>Allow other users to connect to the NovoPRO automatically via QR Code:</p> <ol style="list-style-type: none"> For the first <i>participant</i>, <i>NovoPresenter</i> automatically generates a QR code on your Android device's home directory (which is mirrored on your projector or TV) to allow other subsequent users to connect to your NovoPRO automatically. Subsequent users can follow the steps described above to scan the QR code and connect automatically to your NovoPRO. Upon starting the



- NovoPresenter*, you should be able to find the QR code image being displayed.
2. a) After making a connection with your NovoPRO, you can also display a larger QR code for others to login by tapping the session information tab.
 - b) A larger QR code with session information will be displayed. Click **Ok** when done.

3.3.1.2 Connect to your NovoPRO device manually

If you need to configure login information manually before connecting to your NovoPRO, this is the preferred connection option. After launching the *NovoPresenter* app, tap the  tab (as seen in the screenshot below) and access the configuration options.

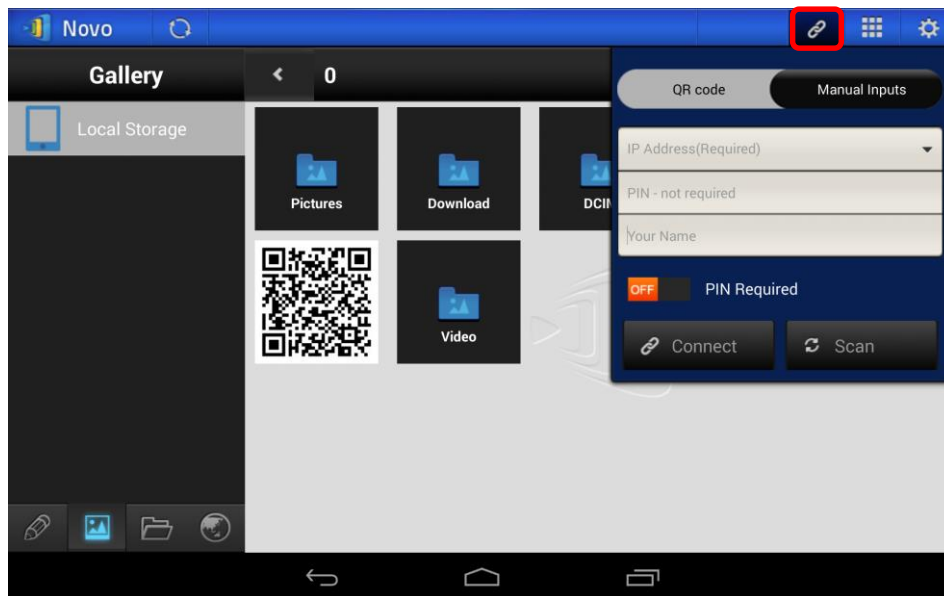

Function	Description
----------	-------------

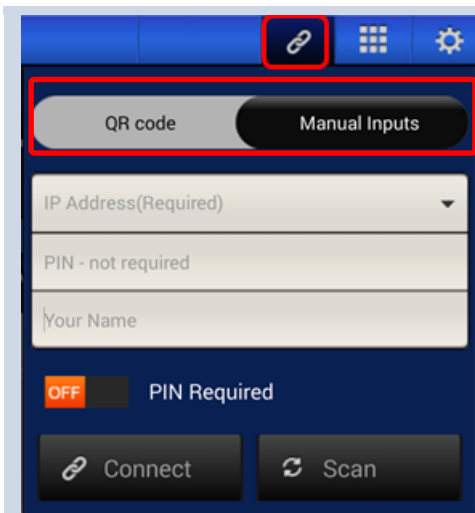

Manual configuration option:
Toggle the **QR code / Manual Inputs** switch to the **Manual Inputs** position.

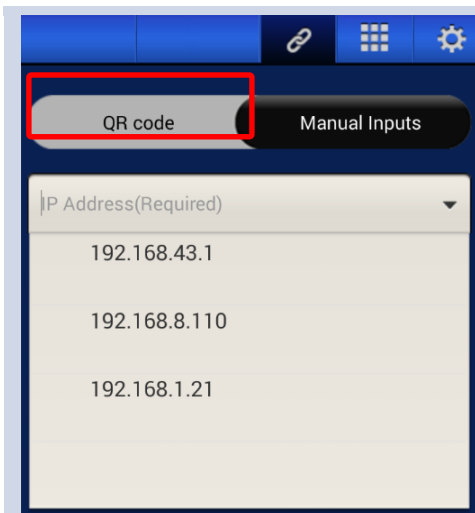

IP address:
Manually enter the IP address shown on your NovoPRO home screen here, or select an entry from the drop-down menu that matches the IP address shown on your NovoPRO home screen. You can tap the **Scan** button to scan the IP addresses of all available NovoPROs within the same subnet. Select the drop-down menu to see the available NovoPROs within your area. Example: [192.168.43.1](#).

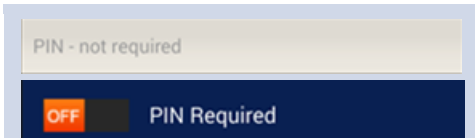

PIN:
If a PIN code is required to connect to the NovoPRO, check the **PIN Required** box and enter the PIN shown on the NovoPRO home screen. If a PIN code is not required, uncheck the **PIN Required** check box.

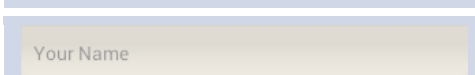

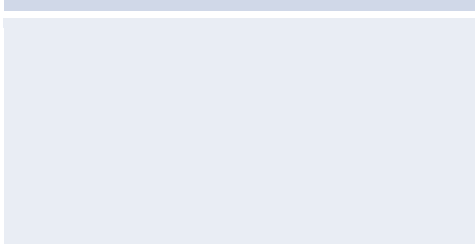

Your Name:
(Optional) Manually enter a name for this tablet to be identified in the presentation group among other *participants*. Example: Jennifer.
(Note: If a name is not entered in this field, the default name for your device will be used.)

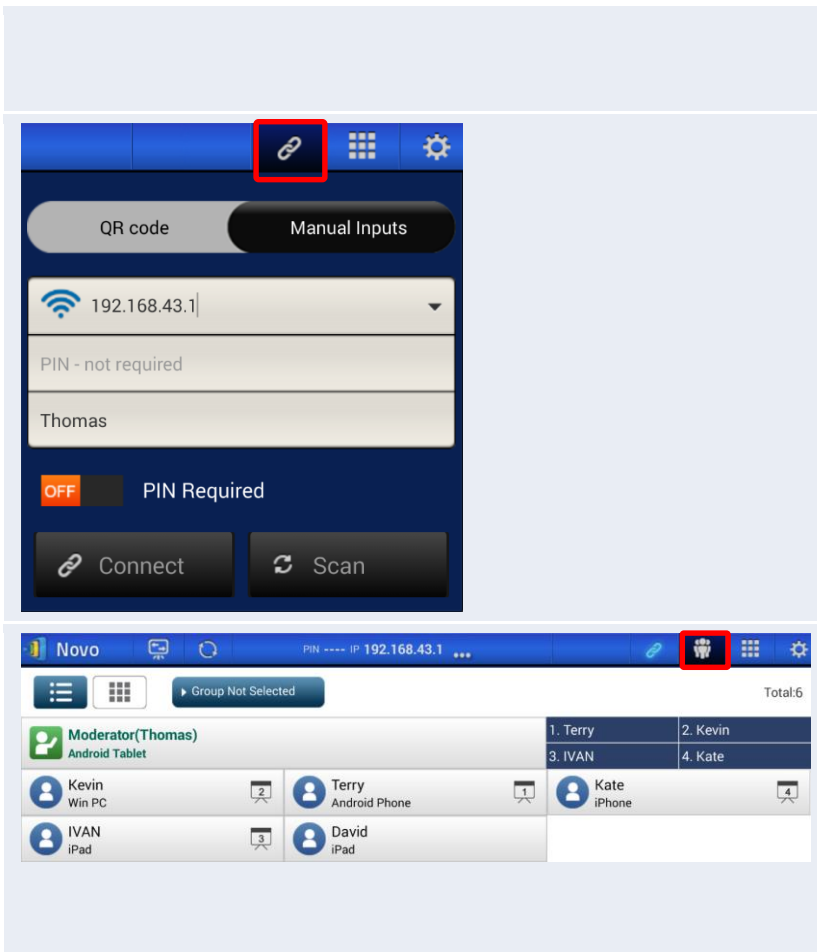

Make connection:
Tap the  button. If you are the first *participant*, this will start a presentation group on your NovoPRO. If you are not the first *participant*, you will be joining a presentation group.





Confirm connection:
 After your *NovoPresenter* app on your Android tablet is connected successfully to your *NovoPRO*, you will see the connection tab light up blue . If you are the first *participant*, you will see that your Android tablet's on-screen display is wirelessly mirrored on your projector or TV. You can slide the PIN requirement switch to **OFF** or **ON** to disable or enable usage of a PIN code.

View participants list:
 You can tap the  tab to see the current *participant* list. Example: There are a total of six *participants* in the presentation group. Thomas is *Moderator*. However, he is not making a presentation at the moment. He has assigned Kevin, Terry, Kate, and Ivan to be the four *presenters*.

3.3.2 Step 2: Make a presentation



Once you have started or joined a presentation group, you can make a presentation with the contents stored on your tablet, local network, or the Internet. There are three tabs in the lower left corner of the *NovoPresenter* home screen:

-  Tap this tab to present an image stored on your tablet.
-  Tap this tab to present a document stored on your tablet.
-  Tap this tab to present a Web page.

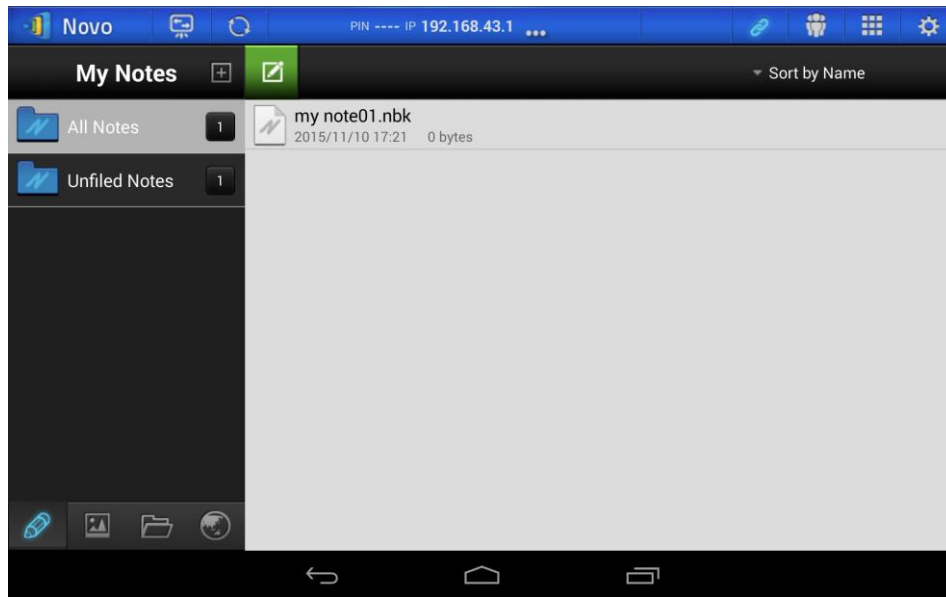
3.3.2.1 My Note (Education Edition only)



This NovoPresenter feature is a virtual whiteboard that allows tablet users to create, manage and display notes in a NovoPRO session.

Function	Description
	<p>Launch My Note: Tap  on the lower left corner of the screen.</p>
	<p>Create a new note presentation: Tap  on the top of the screen.</p>
	<p>Enter your note name: Type a name for your note in the “Create a New Note” dialog box and tap “YES”.</p>

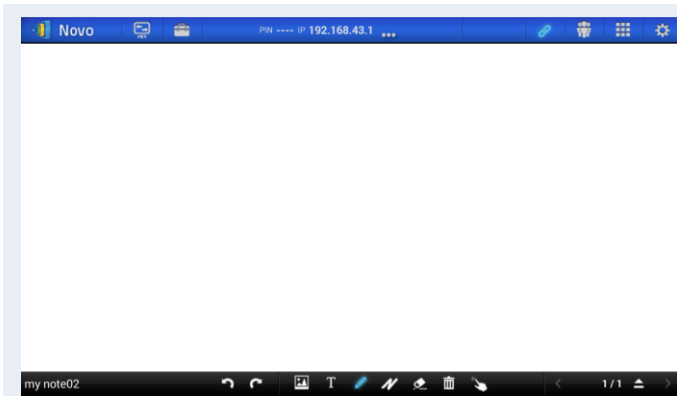

Start making a note:

Your blank note will now open on your screen.

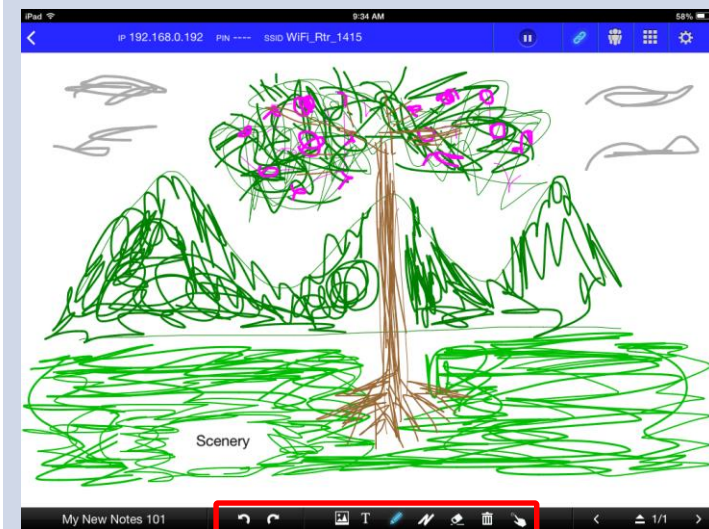



Use the note tools:

The note tools are located on the bottom of the screen. Tap an icon for the desired function.

 Insert a picture stored on your Android tablet.

 Type texts onto the screen. You can reposition your text by dragging it across your screen with your finger.

 Make a drawing on the screen.

 Mark or highlight something on screen.

 Erase texts, drawings, or highlights.

 Clear changes without saving.

Note: This is one of the two trash can icons visible on the *My Notes* screen. The clear icon is on a solid black background in the lower middle of the screen.)

 Move an image to another location. Tap this button and drag the image to its new position.

 Undo a change.

 Redo a change.

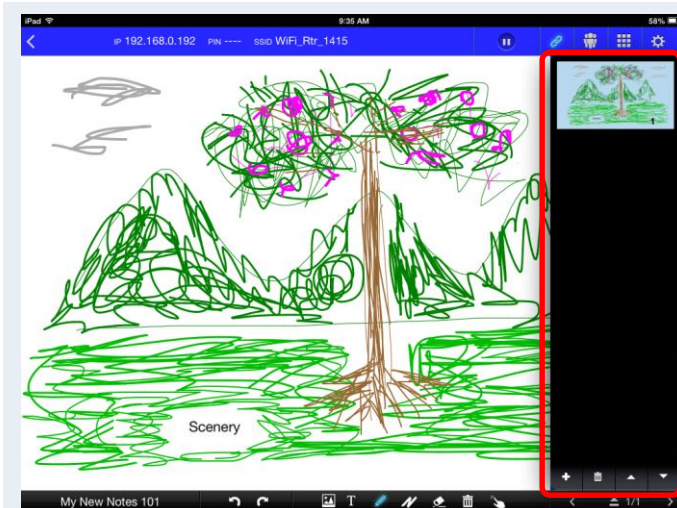



Add additional pages to My Notes presentation:

The page management tools are located in the add-page options pane on the right side of the screen.

 Open the add-page options pane.







 Close the add-page options pane.

 Add a new page.

 Select a page by tapping its thumbnail.

 Delete the selected page.

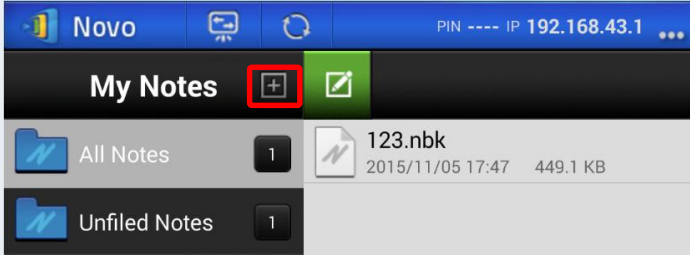
Note: This is one of two trash can icons visible on the

	<p>My Notes screen. The delete page icon is on a dark grey background in the lower right side of the screen.</p> <p> Move the selected page up.</p> <p> Move the selected page down.</p>
	<p>Close and save changes:</p> <p> (Android) Tap to close and save your changes to your note file.</p> <p> (iPad) Tap to close and save your changes to your note file.</p>
	<p>Organize your notes with Subject folders:</p> <p> Tap this icon to add a new subject folder. When the “Add a Subject” dialog box appears, enter the name for the new subject folder.</p>

3.3.2.2 Presenting an image

One quick way to import presentation files onto an Android tablet is to connect to a computer via USB cable. Drag and drop photos and documents onto the tablet as you do with a USB storage device. A sample screen is provided below.



Function	Description
	<p>Navigation:</p> <ol style="list-style-type: none"> 1. Tap the tab to access folders containing image files. It will light up blue. 2. Navigate to a folder by tapping the selected folder. 3. Tap the tab or the back key at any time to return to previous folder.
	<p>Image thumbnails:</p> <p>You will see image thumbnails displayed once you navigate to a folder with images. You can select a thumbnail to view the full image.</p> <p>Example: Tap a cartoon image thumbnail.</p> <p>Note: Tap tab or the back key at any time to return to the previous folder. Tap tab at any time to refresh the screen.</p>

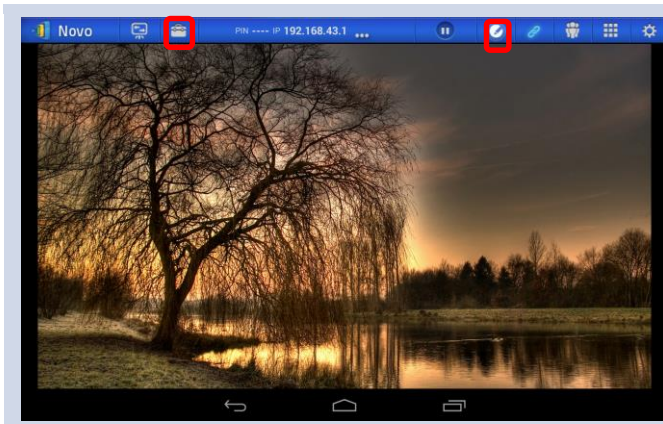

Image presentation:

The selected image will be displayed in full screen. You can zoom in on the image by sliding two fingers apart, or you can zoom out on the image by sliding two fingers toward each other.

If you have more than one image in the same folder, you can swipe your finger left or right on the screen to advance to the next or previous image.

To return to the *Image Thumbnails* page, tap the



tab. To use the on-screen annotation tools,

tap the tab.

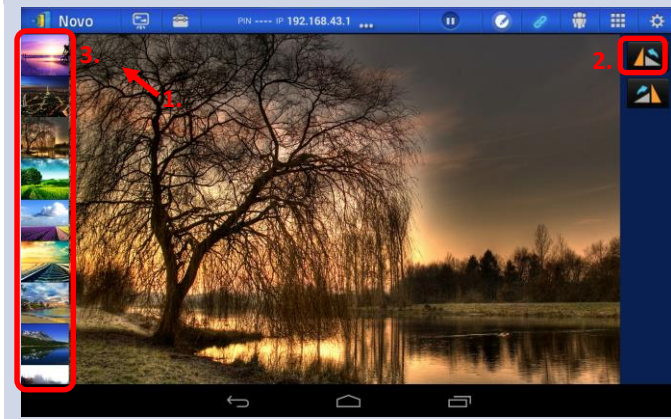
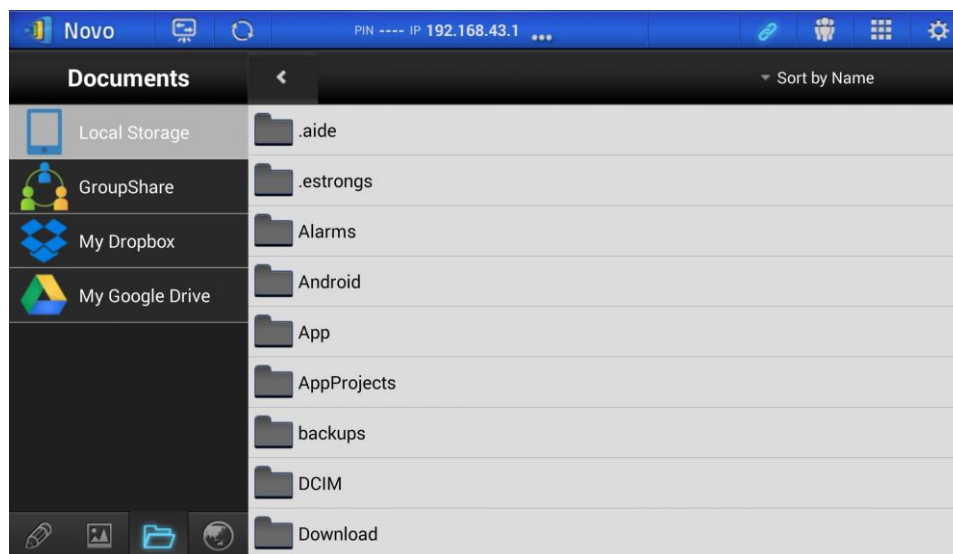

Image presentation control:

1. Tap any image area to show/hide the image presentation control items.
2. Tap to rotate the image counterclockwise, or tap to rotate the image clockwise.
3. To quickly select another image for presentation, drag the image thumbnail bar up or down, and then tap the image you wish to select.

3.3.2.2 Presenting a document (local storage)



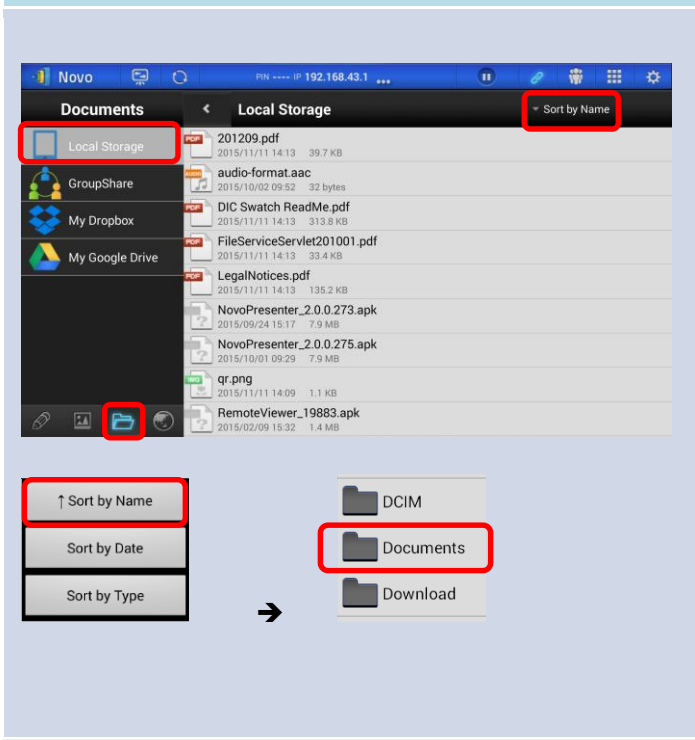

Function	Description
----------	-------------





Navigation:

Tap  tab to access folders with supported document types. It will light up blue.

Tap  or  tab (or any other tab of your storage device) and browse a folder containing documents. If you wish to sort the folder list into a desired order, tap the drop-down menu **Sort by...**, then select one of the following options:

- Sort by Name
- Sort by Date (default)
- Sort by Extension

Example: Tap the **Sort by...** drop-down menu. Tap the option *Sort by Name*, and then tap the *Documents* folder.

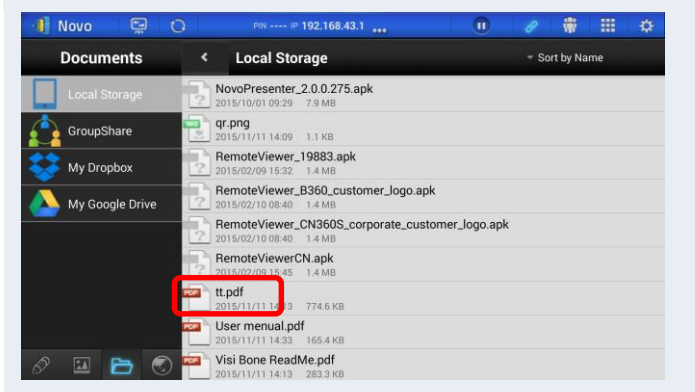

Note: You can tap  tab or the back key  at any time to return to the previous folder. Also, you can tap  tab at any time to refresh the screen.



Document list:

Once you enter a folder with documents supported by *NovoPresenter*, tap the desired document.

Example: Tap the document “tt.pdf”.

Note: You can tap the  tab or the back key  at any time to return to the previous folder.

Also, you can tap the  tab at any time to refresh the screen contents.



Document presentation:

The selected document (a PDF, for example) will be displayed in full screen. You can zoom in on the document by sliding two fingers apart, or you can zoom out of the document by sliding two fingers toward each other.

To scroll down or move to the next page, slide your finger up or drag the scroll bar down. To scroll up or move to the previous page, slide your finger down or drag the scroll bar up.



To return to the *Document List* page, tap  tab.

To use the on-screen annotation tools, tap  tab.

3.3.2.3 Presenting a document (with Dropbox)

To present with documents residing in Dropbox, please follow steps listed in the table below.

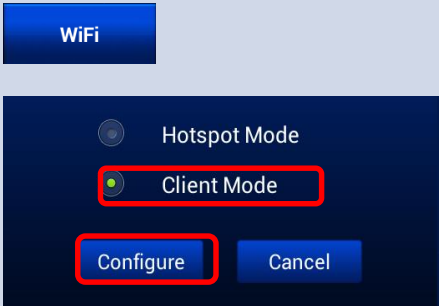
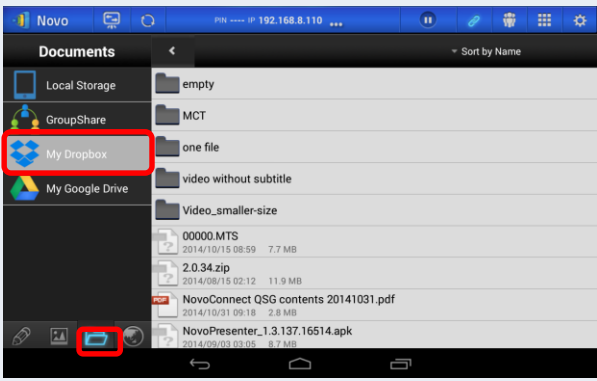
(Note: For Education Edition all participants will automatically allow screen preview.)

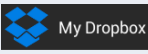
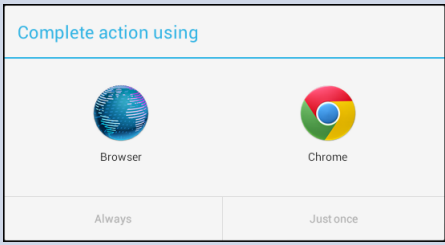
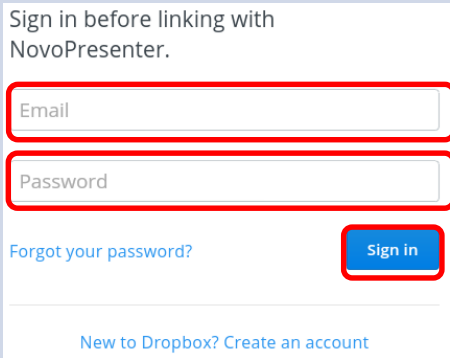
Function	Description
	<p>Set Your NovoPRO to Client Mode: Set your NovoPRO's Wi-Fi mode to Client Mode and connect to a router with Internet access. Please refer to the <i>Remote Viewer</i> chapter for more details.</p>
	<p>Select Dropbox as the document source: Tap the folder tab . It will light up blue. Tap the  tab.</p>
	<p>First time using Dropbox in NovoPresenter: Upon first use of the <i>NovoPresenter</i> Dropbox feature, a link between <i>NovoPresenter</i> and your Dropbox account will need to be established. Choose a Web browser to access the Dropbox link page.</p>
	<p>Enter your Dropbox <i>Email</i> and <i>Password</i>, and then tap the Sign In button.</p>

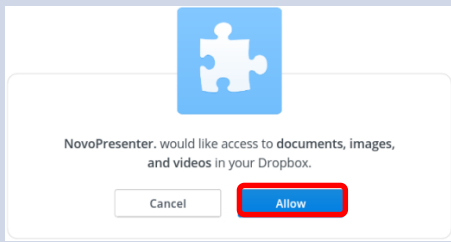

Tap the **Allow** button to permit *NovoPresenter* to access your Dropbox documents. You will then be redirected back to *NovoPresenter*.

Note: If your Android tablet is disconnected from your NovoPRO during the Dropbox setup, simply reconnect to your NovoPRO using the procedures in “Step 2: Connect to your NovoPRO device”.

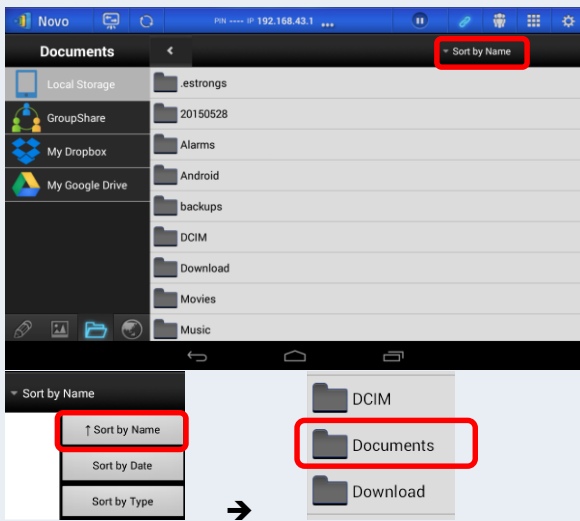



Navigation:

If you wish to sort the list into a desired order, tap the drop-down menu **Sort by...**, then select one of the following options:

- Sort by Name
- Sort by Date (default)
- Sort by Extension

Example: Tap the **Sort by...** drop-down menu. Tap the option *Sort by Name*, and then tap the *Documents* folder.

Note: You can tap the  tab or the back key  at any time to return to the previous folder.

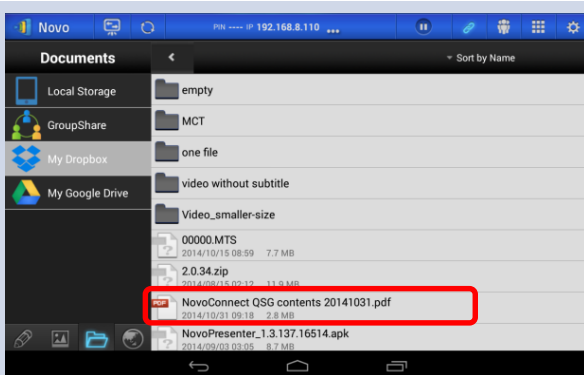

You can also tap the  **Dropbox** tab at any time to refresh the Dropbox list.



Document list:

Once you locate the desired document, you can open and present the document page by page on the Dropbox Web site without downloading the document to your Android tablet.

Example: Tap the document “NovoConnect QSG contents 20141031.pdf”.

Note: You can tap the  tab or the back key  at any time to return to the previous folder.



Scroll Bar

Document presentation:

The selected document (the PDF in this example) will be displayed in full screen. If your

presentation is paused, tap the  button to resume the presentation. You can zoom in on the document by sliding two fingers apart, or you can zoom out of the document by sliding two fingers toward each other.

To scroll down or move to the next page, slide your finger up or drag the scroll bar down. To scroll up or move to the previous page, slide your finger down or drag the scroll bar up.

To return to the *Document List* page, tap the



tab. To use the on-screen annotation tools, tap the  tab.

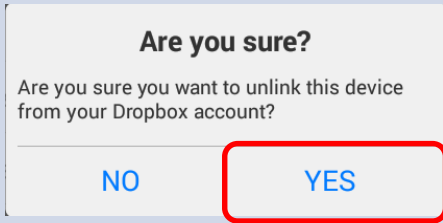
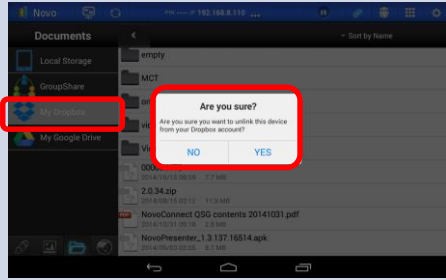

Unlink device from Dropbox or Google Drive:
If you need to unlink the *NovoPresenter* app from your **Dropbox & Google Drive** account, tap the  tab and tap **Unlink device from Dropbox** or **Unlink device from Google Drive**. When the “Are you sure?” confirmation dialog box appears, tap **Yes** to proceed.

3.3.2.4 Presenting with a browser

(Note: For Education Edition all participants will automatically allow screen preview.)

Function	Description
	<p>Set Your NovoPRO to Client Mode: Set your NovoPRO’s Wi-Fi mode to WiFi Mode and connect to a router with Internet access. Please refer to the <i>Remote Viewer</i> chapter for more details.</p>
	<p>Start browsing for a Web page: Tap the Internet tab . It will light up blue. Select one of the three options to access a Web page:</p> <ul style="list-style-type: none"> - Go to... (enter URL address [default]) - Snap a QR code - Browse My Bookmarks (Web site bookmarks)

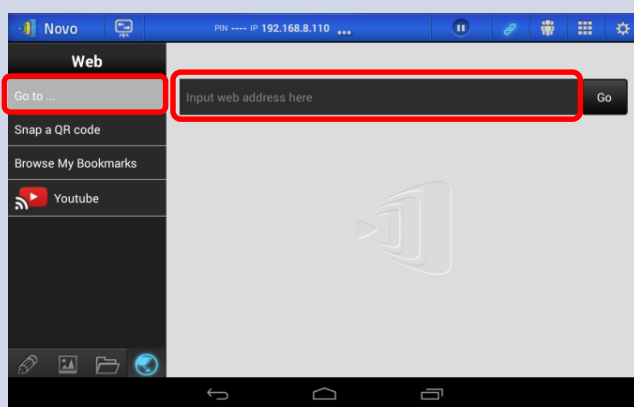

Go to ...:

Tap the **Go to ...** tab.

Enter the Web page URL and tap **Go**.

Example: Enter the URL www.wikipedia.org and tap **Go**.



Snap a QR code:

Tap the **Snap a QR code** tab.

Aim your tablet's camera at a QR code containing Web page information. *NovoPresenter* will detect the embedded URL and go to the corresponding Web page.

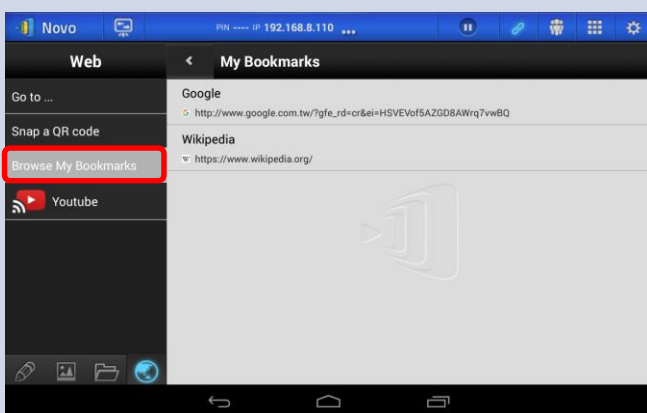

Browse My Bookmarks:

Tap the **Browse My Bookmarks** tab.

From the bookmark list, tap a bookmark of interest to go to its corresponding Web page.

Touch and hold a bookmark for two seconds to edit or delete that bookmark.

Note: The bookmark list may initially be empty. You can add a Web page to the bookmark list while browsing the Web by tapping  tab.



Web page presentation:

The selected Web page will be displayed in full-screen. You can zoom in on the Web page by sliding two fingers apart, or you can zoom out on the Web page by sliding two fingers toward each other. To scroll down or move to the next page, slide your finger up. To scroll up or move to the previous page, slide your finger down.

To add a Web page to the bookmark list, tap the  tab.

To return to **Browse My Bookmarks**, tap the  tab.

tab. To use the on-screen annotation tools, tap the













tab.

3.3.2.5 Annotation

Sometimes you may want to write, highlight, or mark portions of your presentation materials directly on the tablet screen. *NovoPresenter* provides an on screen annotation tool for the presenter to annotate directly on the presentation material without changing the original. You can

enable the annotation tool  by toggling the  tab on, as shown in the screen sample below.





Function	Description
	<p>Touch the  tab to enable the annotation tool.</p> <ul style="list-style-type: none"> Annotate with a red marker Annotate with a blue marker Annotate with a black marker Annotate with a yellow transparent marker Change from annotation (writing) mode to touch panel (operation) mode Trash can Eraser Undo

3.3.2.6 Screenshot and share

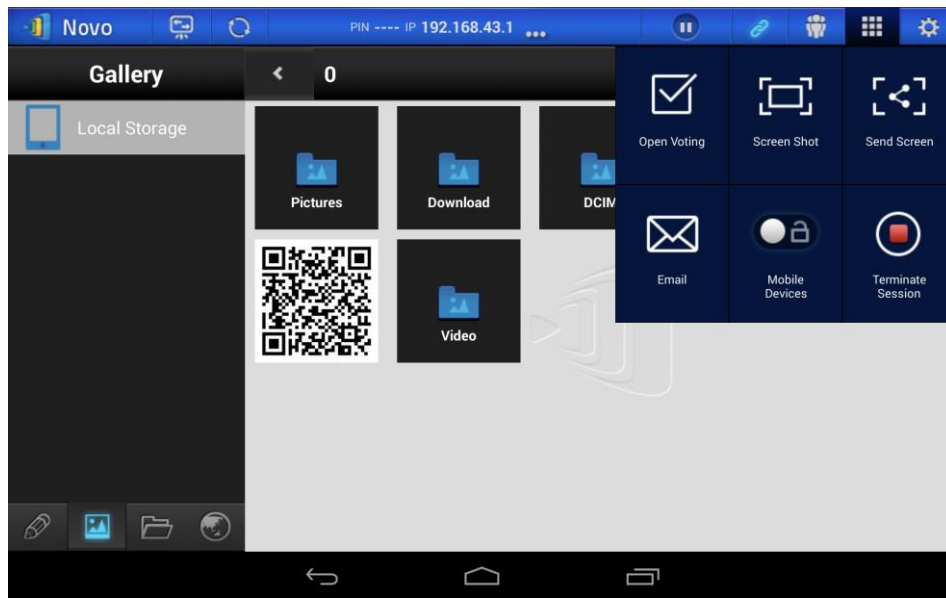
This feature allows users to take screenshots of their display and share them with other users.

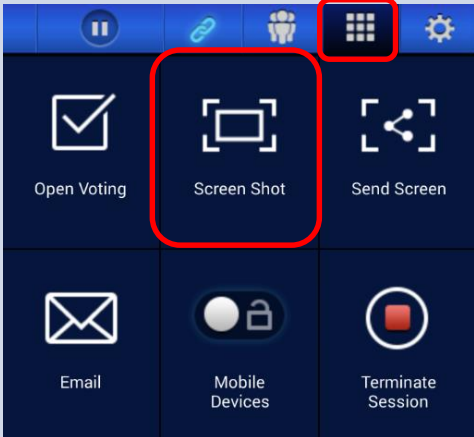

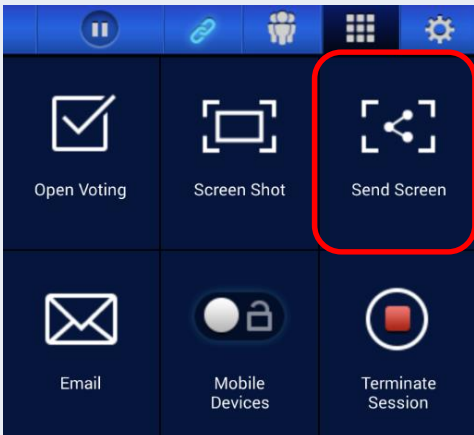
Function	Description
	<p>To take a screenshot: Tap the  tab and tap the Screen Shot area. A file storage directory will be displayed for the location of the saved screenshot.</p>
	<p>To share a screenshot: Tap the Send Screen button, the screenshot will be shared with other users.</p>

3.3.3 Step 3: Presentation management

Once you have started/joined a presentation group, you are ready to make a presentation and collaborate with other *participants*. A sample screen view is provided below.

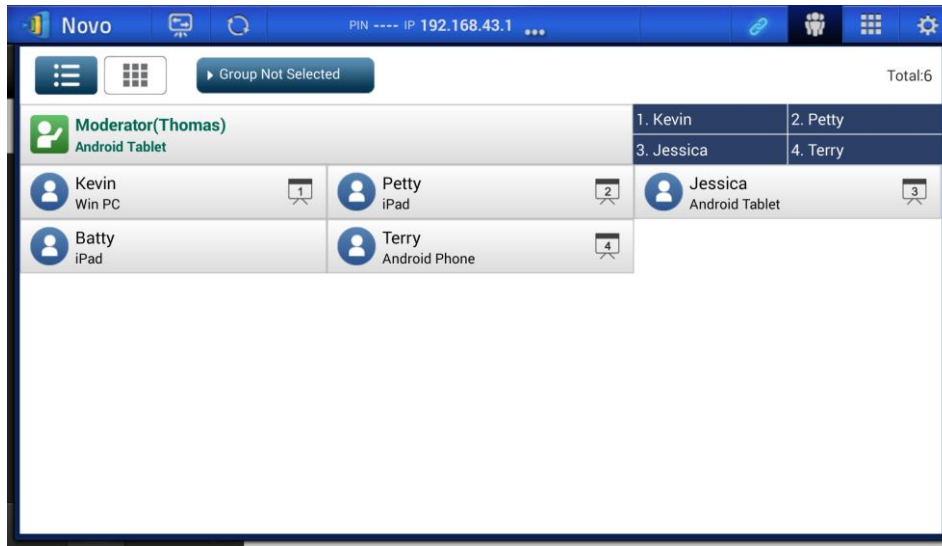

3.3.3.1 Set Moderator mode (*Corporate Edition only*)

The moderator can manage presentations or make a presentation in the split screen.

Function	Description
<p>The screenshot shows the presentation management interface with the moderator mode switch set to 'OFF'. The switch is highlighted with a red box. The interface shows a list of participants: Thomas (Android Tablet), george (Android Phone), and Kevin (Win PC). The total number of participants is 3.</p>	<p>Set the moderator mode:</p> <p>Tap the tab and tap the Moderator On/Off switch to set the moderator mode.</p> <p> : The moderator mode is off.</p> <p> : The moderator mode is on.</p>
<p>The screenshot shows the presentation management interface with the moderator mode switch set to 'ON'. The switch is highlighted with a red box. The interface shows a list of participants: Moderator(Thomas) (Android Tablet), Kevin (Win PC), and george (Android Phone). The total number of participants is 3. Below the list, there is a split screen view with four numbered quadrants (1, 2, 3, 4) and a central navigation icon, also highlighted with a red box.</p>	<p>Manage presentations or make a presentation:</p> <p>The moderator now has the authority to manage presentations or make a presentation in split screen.</p>

3.3.3.2 Role assignment

There are three roles in a presentation group: the *moderator*, the *presenter*, and the *participant*.

The first person to start the presentation group with a NovoPRO is assigned the *moderator* role. Subsequent joiners are assigned the *participant* role. The *moderator* is defaulted to assume the *presenter* role until he hands over the *presenter* role to another *participant*.

To view all current *participants* who have joined the presentation group, tap the  tab.

Function	Description										
	<p>Select the  tab to show <i>participant</i> list.</p> <p> indicates the current <i>moderator</i>.</p> <p> indicates the current <i>presenter</i>.</p> <p> indicates the current <i>presenter</i> that is presenting in the indicated split-screen box number (#1-4). The example here shows a <i>presenter</i> that is presenting in Box #1.</p> <p>*Example: There are six <i>participants</i> in the presentation group – two with Android tablets, one with Windows PC, two with iPads, and one with Android phone. Thomas is the <i>moderator</i> who has automatically denied screen preview. Kevin, Petty, Jessica, and Terry are <i>presenters</i> currently presenting in boxes #1-4 of the four-way split screen, which will be explained in detail later.</p> <p>*: For Education Edition all participants will automatically allow screen preview.</p>										
<p>Example 1:</p> <table border="1" data-bbox="167 1430 574 1587"> <tr> <td colspan="2">Total:2</td> </tr> <tr> <td colspan="2">Kevin</td> </tr> </table> <p>Example 2:</p> <table border="1" data-bbox="167 1654 574 1812"> <tr> <td colspan="2">Total:6</td> </tr> <tr> <td>1. Kevin</td> <td>2. Petty</td> </tr> <tr> <td>3. Jessica</td> <td>4. Terry</td> </tr> </table>	Total:2		Kevin		Total:6		1. Kevin	2. Petty	3. Jessica	4. Terry	<p>The names on this box indicate the current <i>presenters</i> and the total number of current <i>participants</i>.</p> <p>Example 1: Kevin is the only <i>presenter</i>, and there are currently 2 <i>participants</i>.</p> <p>Example 2: Kevin, Petty, Jessica and Terry the four <i>presenters</i>, and there are currently 6 <i>participants</i>.</p>
Total:2											
Kevin											
Total:6											
1. Kevin	2. Petty										
3. Jessica	4. Terry										

3.3.3.3 Role change, screen preview, and four-way split screen

(For Education Edition all participants will automatically allow screen preview.)

Function	Description
	<p>Role change: change a participant to a moderator</p> <p>First select the  tab to show the <i>participant</i> list. Then tap one participant's  icon, whom you want to transfer moderator role to. <i>Please note: only the moderator is allowed for this operation.</i></p>
<p><u>The <i>moderator's</i> screen:</u></p> <div data-bbox="164 661 576 850"> <p style="text-align: center;">Moderator Transfer</p> <p style="text-align: center;">Transfer moderator role to Kevin?</p> <p style="text-align: center;"> <input type="button" value="NO"/> <input type="button" value="YES"/> </p> </div> <p><u>The <i>participant's</i> screen:</u></p> <div data-bbox="164 924 576 1092"> <p style="text-align: center;">Request Confirmation</p> <p style="text-align: center;">Would you like to be the moderator?</p> <p style="text-align: center;"> <input type="button" value="NO"/> <input type="button" value="YES"/> </p> </div>	<p>A dialog box pops up to ask for your confirmation. You have 20+ seconds to click the Yes button to accept or click the No button to reject the requested role change.</p> <p>At the same time, a dialog box will appear on that participant's screen to ask for his/her confirmation. The participant has 20+ seconds to click the Yes button to accept or click the No button to reject the requested role change.</p>
	<p>Role change: change be to be sole presenter</p> <p>First select the  tab to show the <i>participant</i> list.</p>
	<p>Highlight <i>participant</i> Batty by tapping the middle part of the entry of Batty.</p> <p>Then tap the  icon of the split screen selection area to request that Batty be the sole <i>presenter</i>.</p>

Request Confirmation

Would you like to be the presenter?

NO

YES

When a *participant* is asked to be a *presenter*, a dialog box will appear on the *participant's* screen to request confirmation.

The *participant* has 20+ seconds to tap the **Yes** button to accept the new role or tap the **No** button to reject.



To perform screen preview: (Education Edition only)

Tap the  tab to show the *participant* list.

For *Education Edition*, all *participants* will automatically allow screen preview.

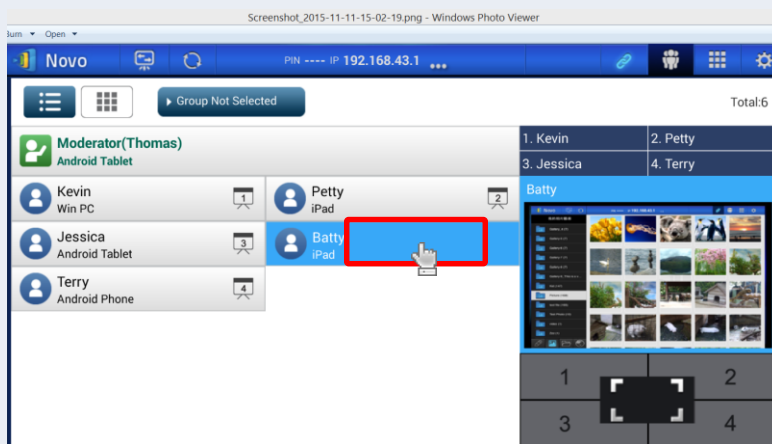

To preview a *participant's* screen, tap the middle part of an entry once

Wait a few seconds for the screen to be sampled and displayed. In this example, Batty's iPad is selected to be previewed.



To perform a four-way split screen presentation:

Tap the  tab to show the *participant* list.

Select a *participant* to make a presentation.

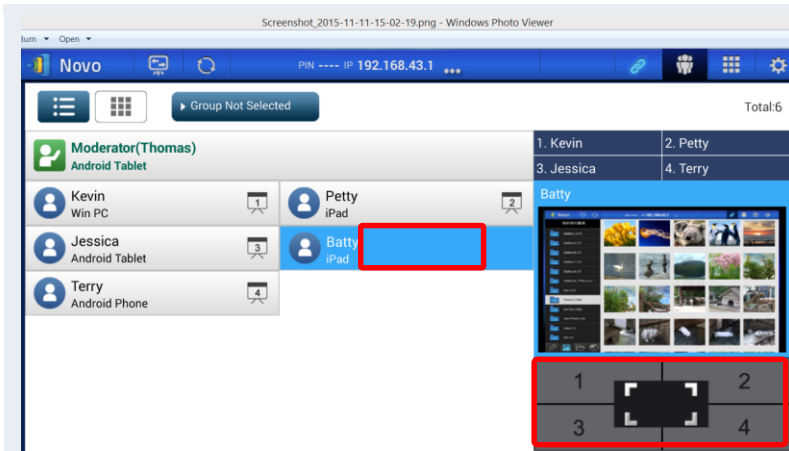

Four-way split screen presentation:

Highlight *participant* Batty by tapping the middle part of the entry of Batty to bring up the split screen selection area



Then tap one of the four boxes (#1-4) in the split screen selection area to assign Batty to perform a presentation on one of the four boxes of the four-way split screen.

Request Confirmation

Would you like to be the presenter?

NO

YES

Batty will receive a request to perform a presentation in one of the four boxes of the four-way split screen.

After Batty accepts (within 20+ seconds) the request by tapping the **Yes** button, Batty's screen will appear on one of the four boxes of the four-way split screen.

3.3.3.4 Pause, resume, and disconnect

(For Education Edition all participants will automatically allow screen preview.)

Function	Description
	<p>To Pause a presentation:</p> <p>Tap the tab to enter the presentation control page.</p>
	<p>Pausing and resuming a presentation:</p> <p>While presenting, toggle between and to pause and resume the presentation respectively.</p>

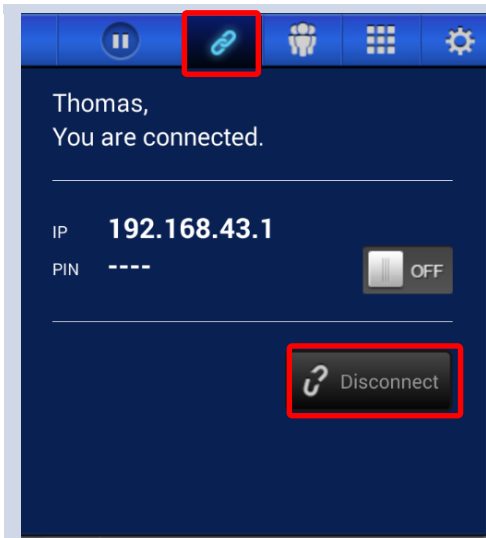

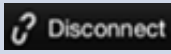

To Disconnect from a presentation group:

1. Tap the  tab to enter the presentation control page.
2. Tap the  button to exit the presentation group.

If the *moderator* exits the presentation session without handing over the *moderator* role, all *participants* will receive a message prompting them to take over the *moderator* role. The first to respond to the prompt will assume the role of the *host*.



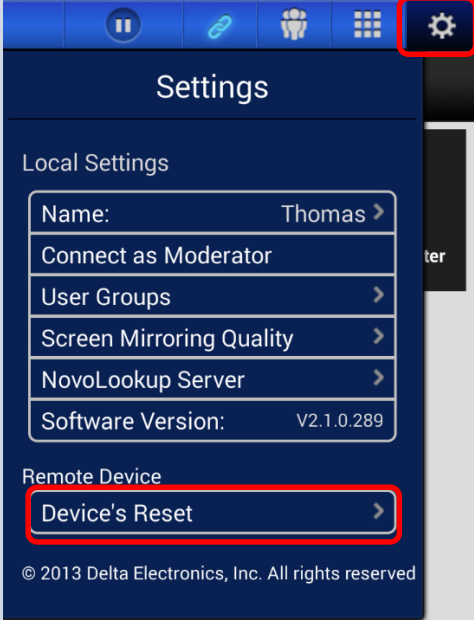

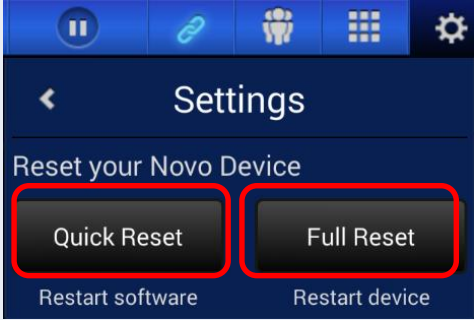
3.3.3.5 Reset and rename local device

Occasionally you may encounter problems with the network or the computer, causing the presentation group to malfunction on your NovoPRO. One way to resolve this problem is to reset the presentation group.

Function	Description
 <p>The screenshot shows the 'Settings' application interface. At the top, there is a navigation bar with several icons, including a gear icon for settings, which is highlighted with a red box. Below the navigation bar, the 'Settings' title is displayed. Underneath, there are sections for 'Local Settings' and 'Remote Device'. In the 'Remote Device' section, the 'Device's Reset' option is highlighted with a red box. The bottom of the screen shows the copyright notice: '© 2013 Delta Electronics, Inc. All rights reserved'.</p>	<p>To perform a Reset:</p> <p>First tap the  tab and tap the  arrow of Device's Reset.</p>
 <p>The screenshot shows the 'Reset your Novo Device' screen. At the top, there is a navigation bar with a back arrow and the 'Settings' title. Below the navigation bar, the title 'Reset your Novo Device' is displayed. Underneath, there are two buttons: 'Quick Reset' and 'Full Reset'. Both buttons are highlighted with red boxes. Below the 'Quick Reset' button, the text 'Restart software' is displayed. Below the 'Full Reset' button, the text 'Restart device' is displayed.</p>	<p>Resetting:</p> <p>Tap Quick Reset to start a presentation group. Tap the Full Reset button to reset the NovoPRO device. The NovoPRO device will restart automatically. Conflicts may occur when multiple <i>participants</i> simultaneously attempt to reset the presentation group or the NovoPRO. The reset privilege priorities are as follows:</p> <ol style="list-style-type: none">1. <i>Moderator</i>: The <i>moderator</i> has the sole privilege to quick-reset the presentation group or the NovoPRO device when the <i>host</i> stays connected to the NovoPRO.2. <i>Presenter</i>: If the <i>host</i> loses connection with the NovoPRO, the current <i>presenter</i> inherits the privilege to quick-reset the NovoPRO.3. <i>Participant</i>: If the <i>host</i> and the <i>presenter</i> both lose connection with the NovoPRO, any <i>participant</i> can quick-reset the presentation group.

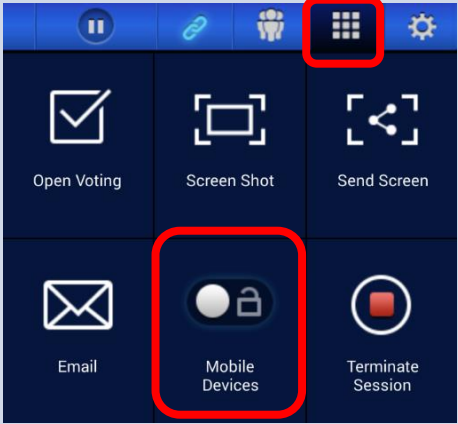

3.3.3.6 Lock/unlock students' tablets (*Education Edition only*)

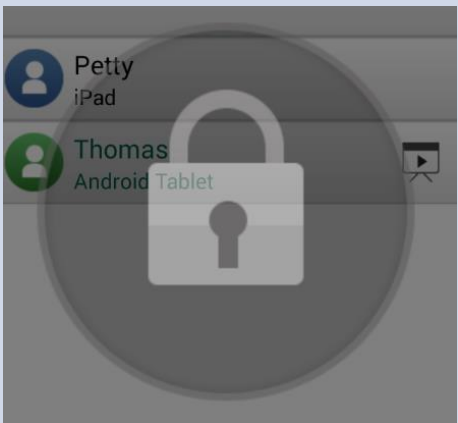
This feature for PCs and tablets allows teachers to lock down student tablets. This feature is only available in the *Education Edition*.

Function	Description
	<p>To lock/unlock students' tablets:</p> <p>Click the  tab to bring up the toolbar page, then click Student Tablets to lock or unlock the students' tablets.</p> <p> : Student tablets are unlocked.</p> <p> : Student tablets are locked.</p>
	<p>Student tablets locked:</p> <p>A lock icon will pop up on the students' tablets to show that the screen has been locked.</p>

3.3.3.7 Terminate session (*Education Edition only*)

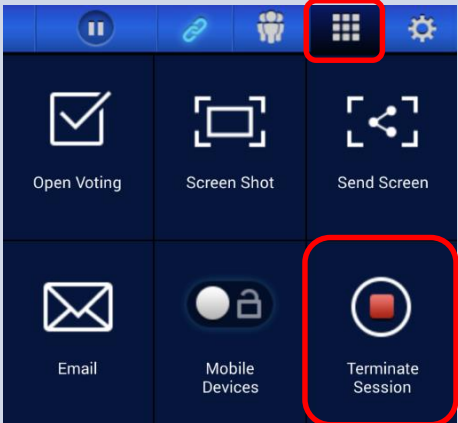
Here you can disconnect all devices with the touch of one button.



Function	Description
	<p>To terminate the session:</p> <p>Tap the  tab and tap Terminate Session.</p>

3.4 Presenting with Chromebook

The Chromebook version *Novo Desktop Streamer* app enables a Chromebook device to connect to a NovoPRO device and join a presentation session, participate in voting and share videos.

3.4.1 Step1: Connect to your NovoPRO device

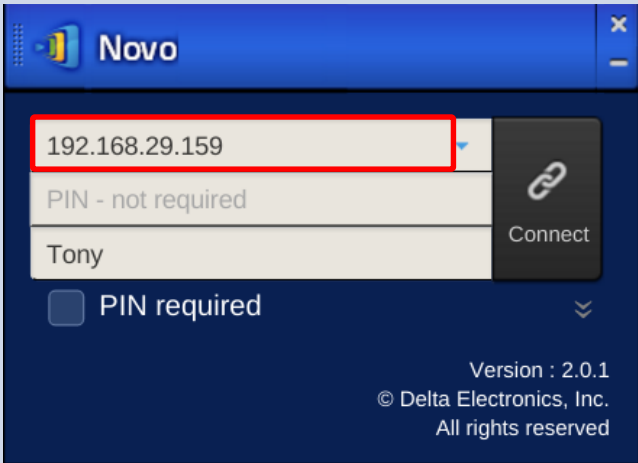
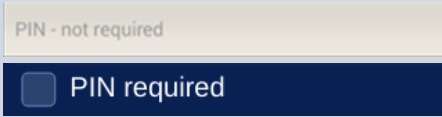
After launching the *Novo Desktop Streamer* app, please follow the steps below to connect to your NovoPRO device.

Function	Description
	<p>IP address: Manually enter the IP address shown on your NovoPRO home screen here, or select an entry from the drop-down menu that matches the IP address shown on your NovoPRO home screen. Example: 192.168.29.159.</p>
	<p>PIN: If a PIN code is required to connect to the NovoPRO, check the PIN Required box and enter the PIN shown on the NovoPRO home screen. If a PIN code is not required, uncheck the PIN Required check box.</p>
	<p>Your Name: (Optional) Manually enter a name for this tablet to be identified in the presentation group among other <i>participants</i>. Example: Tony. (Note: If a name is not entered in this field, the default name for your device will be used.)</p>

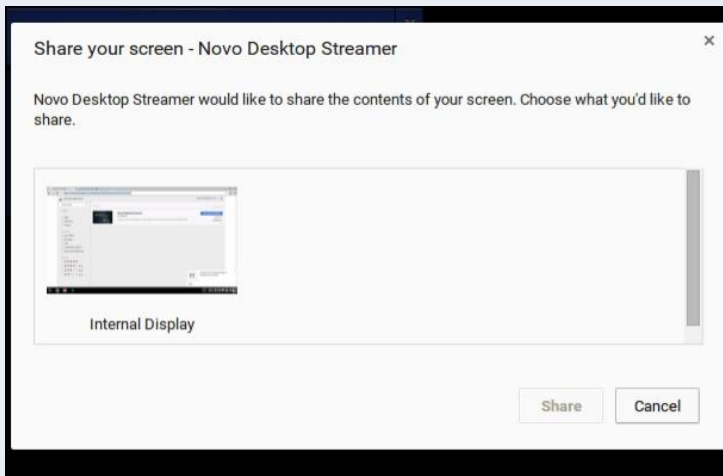

Make connection:

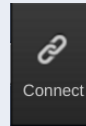

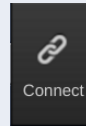
Tap  button to make a connection, and then you will be asked if you would like to share your screen contents. Click on the internal display icon and then click **Share**.

If you are the first *participant*, this will start a presentation group on your NovoPRO. If you are not the first *participant*, you will be joining a presentation group.

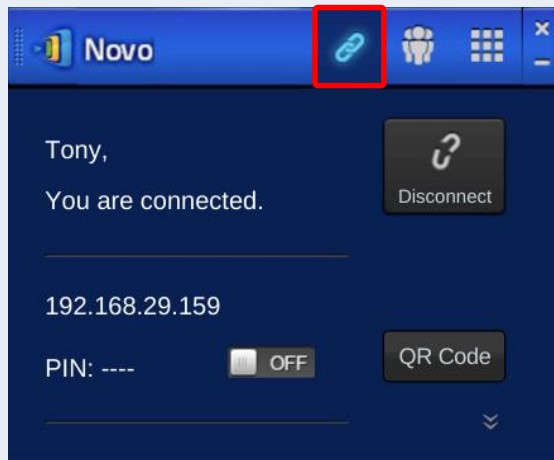

Confirm connection:

After your *Novo Desktop Streamer* app on your Chromebook is connected successfully to your NovoPRO, you will see the connection tab light up blue .

If you are the first *participant*, you will see that your Chromebook's on-screen display is wirelessly mirrored on your projector or TV. You can switch the PIN requirement switch to **OFF** or **ON** to disable or enable usage of a PIN code.

At the same time, you will get a pop up message from Chrome OS at low right corner to indicate that your screen is shared by *Novo Desktop Streamer* App.

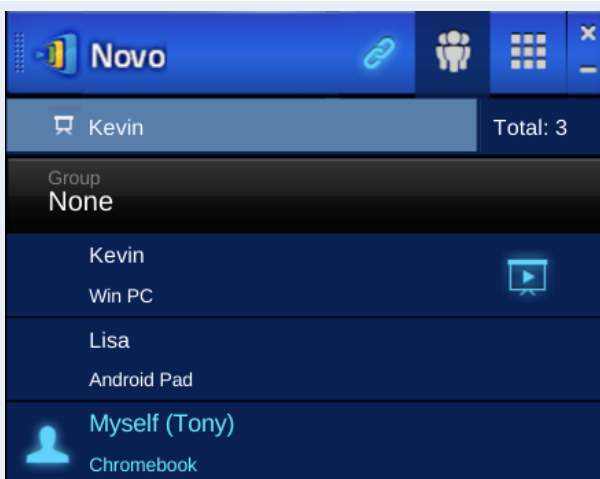
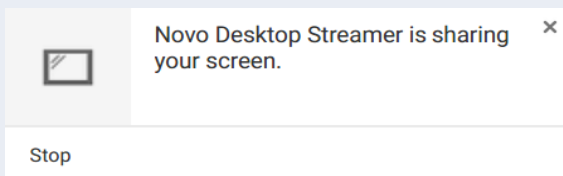

View participants list:

You can tap the  tab to see the current *participant* list.

Example: There are three *participants* in the presentation group. Tony is *Moderator*, and Lisa and Kevin are *participants*. However, Tony is not making a presentation at the moment. He has assigned Kevin to be the *presenter*.

3.4.2 Step 2: Make a presentation

Novo Desktop Streamer enables a Chromebook user to share his/her whole screen to a presentation group. So you can share whatever on your screen such as opening an online presentation file to all participants.

In addition, *Novo Desktop Streamer* allows a Chromebook user to stream videos to the NovoPRO device, do online voting and share his/her file and screenshots to the group.

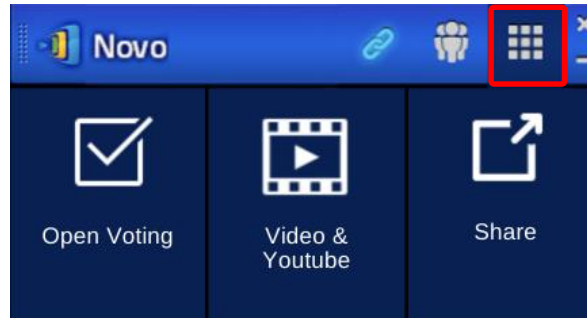

Please refer to the following sections for corresponding operation guideline:

- 3.7 Video file and YouTube streaming.
- 4.2 File sharing
- 4.4 Responding with Voting (iOS, Android, Chromebook)





3.4.3 Step 3: Presentation management

Once you have started/joined a presentation group, you are ready to make a presentation and collaborate with other *participants*.

3.4.3.1 Role assignment

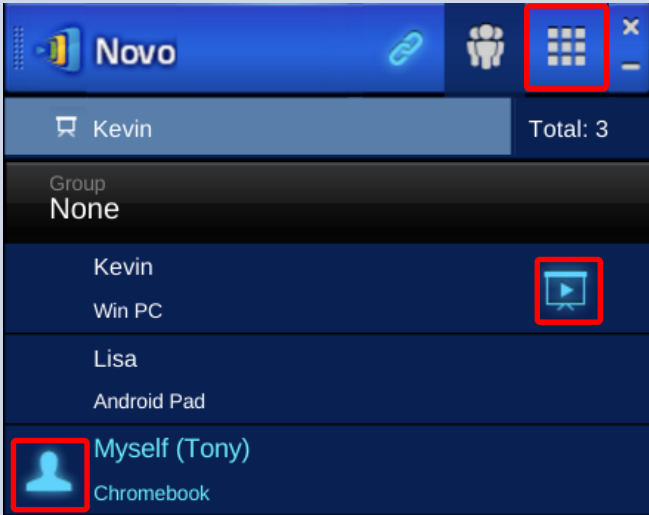

There are three roles in a presentation group: the *moderator*, the *presenter*, and the *participant*. The first person to start the presentation group with a NovoPRO device is assigned the *moderator* role. Subsequent joiners are assigned the *participant* role. The *moderator* is defaulted to assume the *presenter* role until he hands over the *presenter* role to another *participant*.

To view all current *participants* who have joined the presentation group, tap the  tab.

Function	Description
	<p>Select the  tab to show <i>participant</i> list.</p> <p> indicates the current <i>moderator</i>.</p> <p> indicates the current <i>presenter</i>.</p> <p> indicates the current <i>presenter</i> that is presenting in the indicated split-screen box number (#1-4). The example here shows a <i>presenter</i> that is presenting in Box #1.</p> <p>Example: There are three <i>participants</i> in the presentation group – one with Android tablet, one with Windows PC, and one with Chromebook. Tony is the <i>moderator</i> who has automatically denied screen preview. Kevin and Lisa are <i>presenters</i>.</p> <p><i>For Education Edition</i> all participants will automatically allow screen preview.</p>

3.4.3.2 Role change, screen preview, and four-way split screen

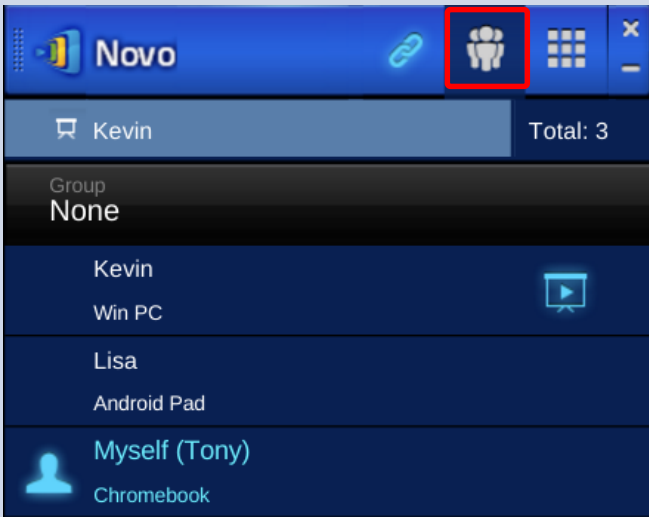
(*For Education Edition* all participants will automatically allow screen preview.)

Function	Description
	<p>Role change: change a participant to a moderator</p> <ol style="list-style-type: none"> Select the  tab to show the <i>participant</i> list.

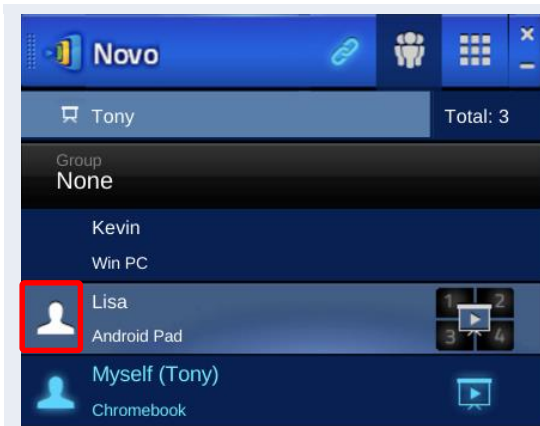

2. Move your mouse cursor to one *participant* Lisa.
3. Tap Lisa's  icon to hand over *moderator* role to her.

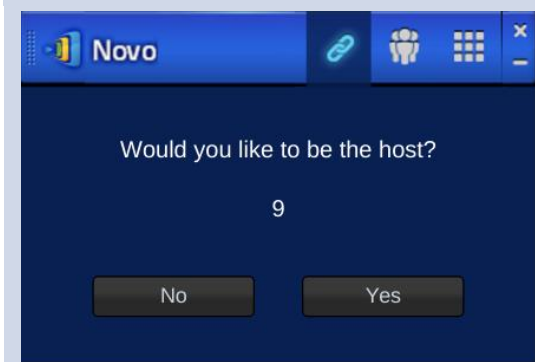

When a *participant* is asked to be a *moderator*, a dialog box will appear on the *participant's* screen to request confirmation.

The *participant* has 20+ seconds to tap the **Yes** button to accept the new role or tap the **No** button to reject.



At the same time, a dialog box will appear on the *moderator's* screen to request confirmation.

The *moderator* has 20+ seconds to tap the **Yes** button to accept the new role or tap the **No** button to reject.

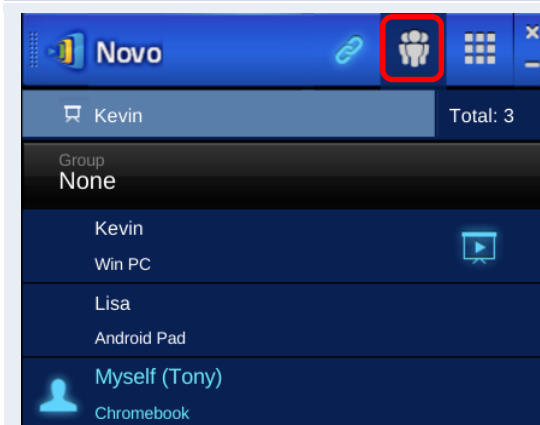

Role change: change to be a presenter

1. Select the  tab to show the *participant* list.

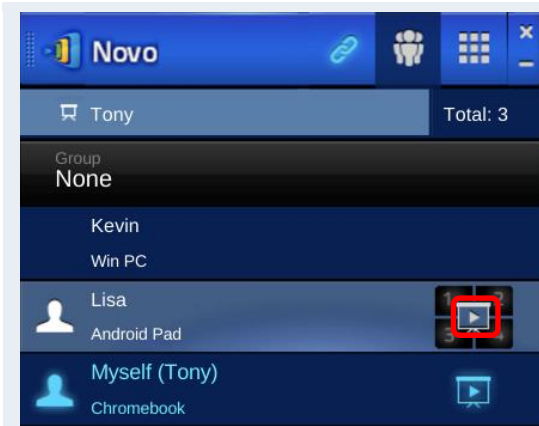

2. Move your mouse cursor to one *participant* Lisa.
3. Tap  icon to transfer *presenter* role to her.

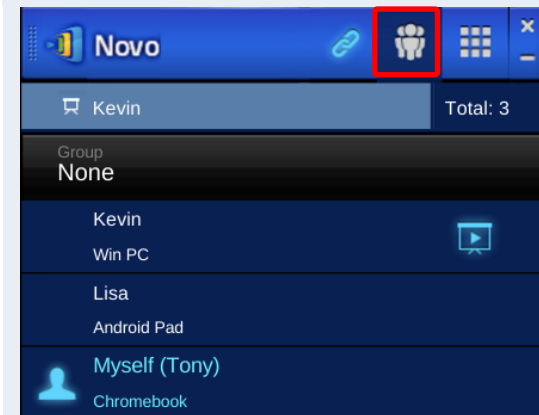

To perform screen preview: (Education Edition only)

Tap the  tab to show the *participant* list.

For *Education Edition*, all *participants* will automatically allow screen preview.

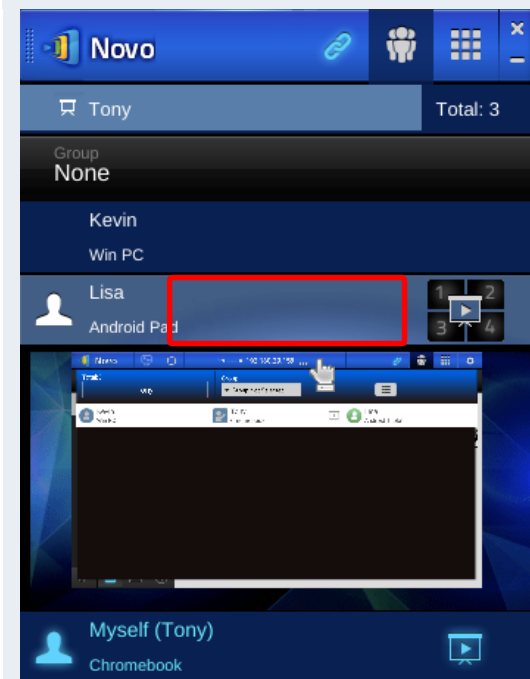

To preview a *participant's* screen, tap the middle part of an entry once.

Wait a few seconds for the screen to be sampled and displayed. In this example, Lisa's Android tablet is selected to be previewed.

After you preview Lisa's screen, if you decide to share her screen, you can click the middle of

 icon to present Lisa's content to the screen.

You can tap the middle part of an entry to close screen preview.

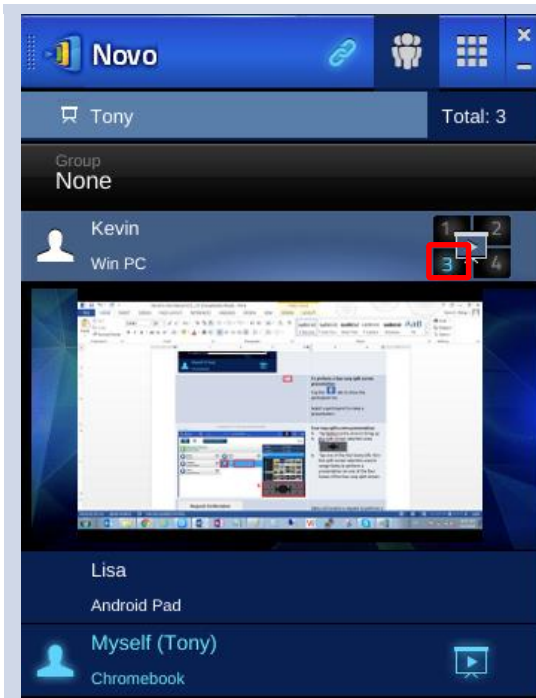

To perform a four-way split screen presentation:

You can repeat the above screen preview process, and then move your mouse to one of 4 split screen numbers, which you want to cast its screen to. At this moment, you can see its screen number turns to blue.



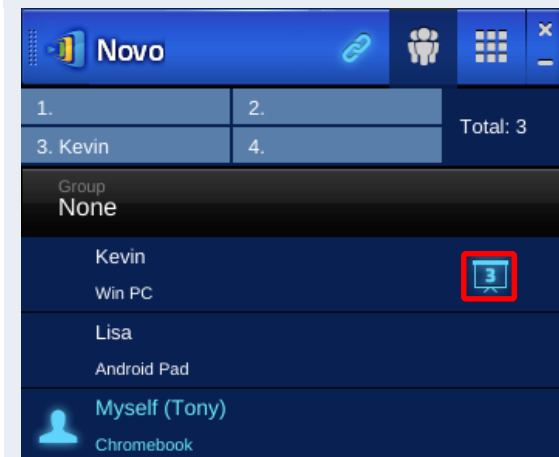

Tap one of the four boxes (#1-4) in the split screen selection area to assign Kevin to perform a presentation on one of the four boxes of the four-way split screen.



After the above action, you can see  icon, which indicates that it has been presented on #3 of the split-screen.

3.4.3.3 Pause, resume, and disconnect

Function	Description
	<p>To Pause a presentation:</p> <p>Tap the  tab to enter the presentation control page.</p>

	<p>Pausing and resuming a presentation:</p> <p>While presenting, toggle between  and  to pause and resume the presentation respectively.</p>
	<p>To Disconnect from a presentation group:</p> <ol style="list-style-type: none"> 4. Tap the  tab to enter the presentation control page. 5. Tap  button to exit the presentation group. <p>If the <i>moderator</i> exits the presentation session without handing over the <i>moderator</i> role, all <i>participants</i> will receive a message prompting them to take over the <i>moderator</i> role. The first to respond to the prompt will assume the role of the <i>host</i>.</p>

3.5 Presenting with the NovoPRO device

Your NovoPRO device allows you to make presentations with the computing power of the device itself without the assistance of a computer. Your presentation files may reside in a microSD card, USB memory drive, the internal storage of your NovoPRO device, or in your Dropbox online storage account (Internet connection required for Dropbox access).

The steps for making a presentation with only your NovoPRO are as follows:







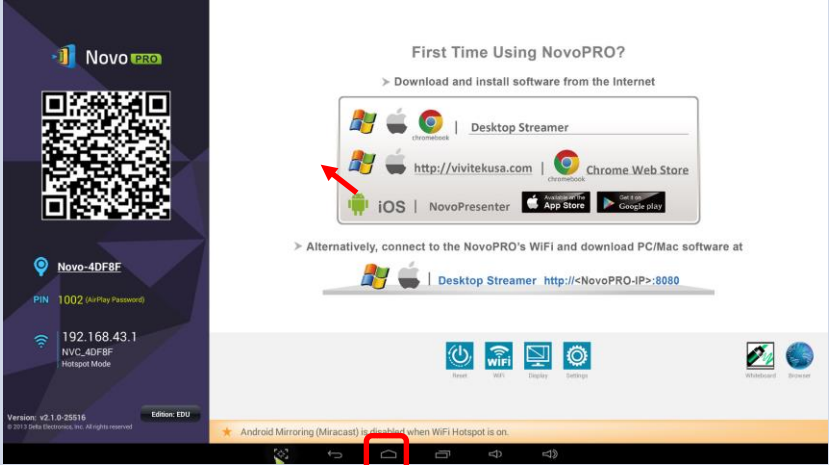

- 1) If your presentations are stored on a microSD card, please insert the microSD card into the microSD card slot.
- 2) If your presentations are stored on a USB memory drive, please first connect a USB hub to your NovoPRO device, then connect a mouse and a USB memory drive to the USB hub.
- 3) You can also save your presentation files in the local storage of your NovoPRO or in your Dropbox online.

Note: You need a USB mouse to operate the following steps.

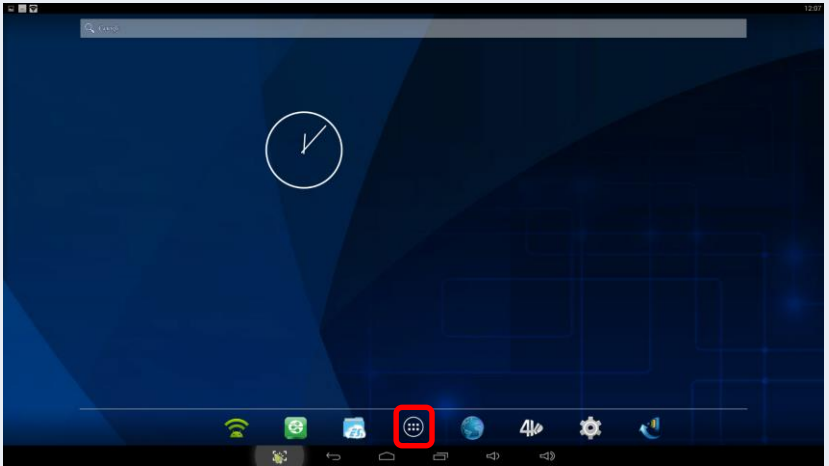
You are now ready to make a direct presentation with your NovoPRO.

The following table shows detailed steps on how to make a direct presentation:

Function	Description
	<p>To present directly with your NovoPRO: Click an empty space of the NovoPRO home screen. Then click the home button .</p>
	<p>To present directly with your NovoPRO: Click the apps button .</p>
	<p>To present directly with your NovoPRO: Click <i>NovoPresenter</i> .</p>

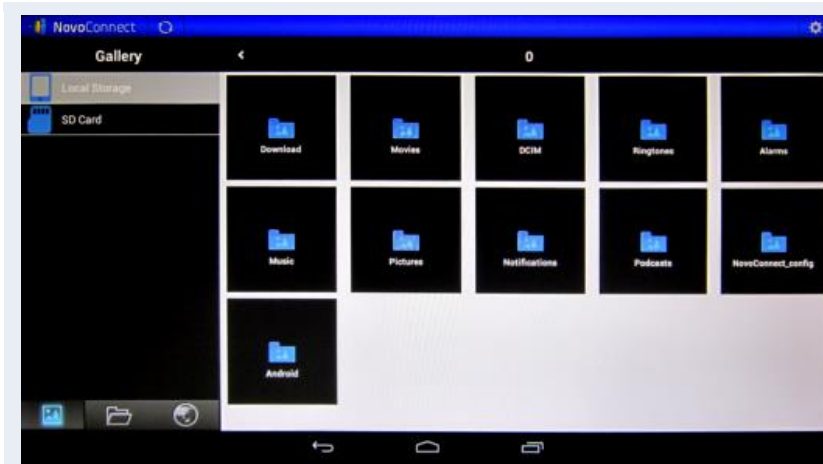

To present directly with your NovoPRO:

Please go to the section [3.3.2 Step 2: Make a Presentation](#) for more details on making a presentation with *NovoPresenter*. Ignore instructions for **Snap a QR Code**.

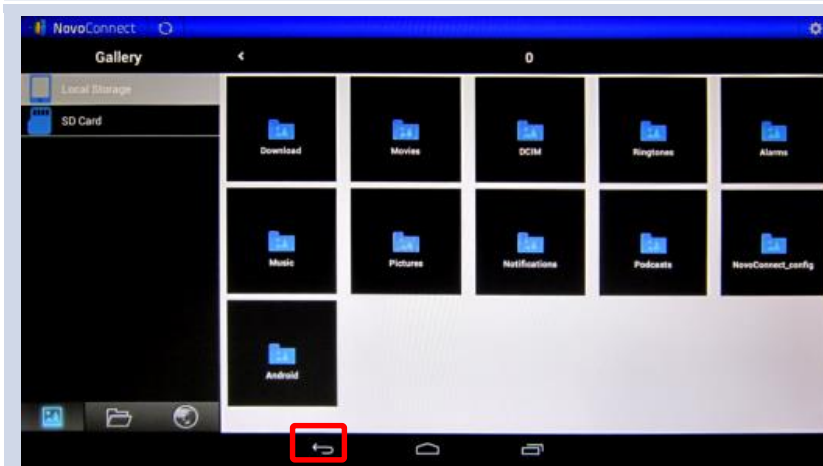



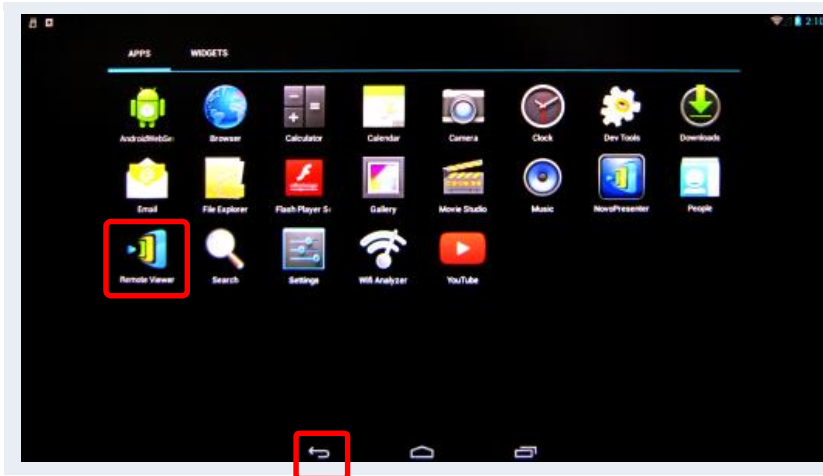

To return to *Remote Viewer*:

Click the back key  one or more times until *NovoPresenter* disappears.



To return to *Remote Viewer*:

Click ***Remote Viewer*** .
 (Note: If you do not see the app list as shown on the left, click the home button , next click the apps button , and then click ***Remote Viewer*** .

To return to *Remote Viewer*:

Click the back key  one or more times until the system bar disappears.

3.6 User groups

This feature allows moderator to organize and monitor participants (members)

3.6.1 Two Ways to organize a group

A Group consists of a group name, a moderator, and some members.

- Group name and moderator are self-explanatory.
- A member's entry has two fields, Name and Device
 - Field "Name": member's name
 - Field "Device": device's name or some sort of number (like student ID)

There are two ways to organize a group.

1. Use Member Name

In the following figure, member's "Device" fields are left empty. For a classroom teacher, she/he will ask students to use their name to connect to a NovoPRO session.

The screenshot displays a user interface for managing a group. At the top, there are two sections: 'Group' and 'Moderator (Teacher)'. The 'Group' section has a 'Name' field containing 'Math Class'. The 'Moderator (Teacher)' section has a 'Name' field containing 'Kevin' and a 'Device' field containing '(Optional)'. Below these sections is a list of 'Members (Students)'. The list contains five entries: Emily, David, Robert, Jessica, and Willson. Each entry has a small person icon to the left of the name and '(Optional) Device' below the name. A blue bar highlights the 'Willson' entry. To the right of the 'Willson' entry is a trash can icon. A '+ Member' button is located at the top right of the members list. At the bottom of the interface are three buttons: 'Done', 'Save', and 'Close'.

In this case, only the students (Member name) in this group can connect to this NovoPRO session.

2. Use Device name

In the following figure, member's "Device" field is filled. For a classroom teacher, the "Device" field could be student ID or a series of numbers, such as Tablet-01, Tablet-02, etc.

With this Group feature, the teacher will see "human-readable" names (Emily & Jerry) instead of Tablet-01 & Tablet-02 in the user list during a NovoPRO session.

Group		Moderator (Teacher)	
Name:	Math Class	Name:	Kevin
		Device:	(Optional)

Members (Students)		+ Member
Emily	Tablet-01	
David	Tablet-02	
Robert	Tablet-03	
Jessica	Tablet-04	
Willson	Tablet-05	

Done Save Close

In this case, only the devices (Device name) in this group can connect to this NovoPRO session.

3.6.2 Create a User Group file

Notes: This feature is available to NovoPRO PC/Mac software but not Chromebook/tablet/phone Apps.

1. Open the *NovoPRO Desktop Streamer* application and expand "Settings" tab. Click on button "Edit" to add, change, and delete user groups.

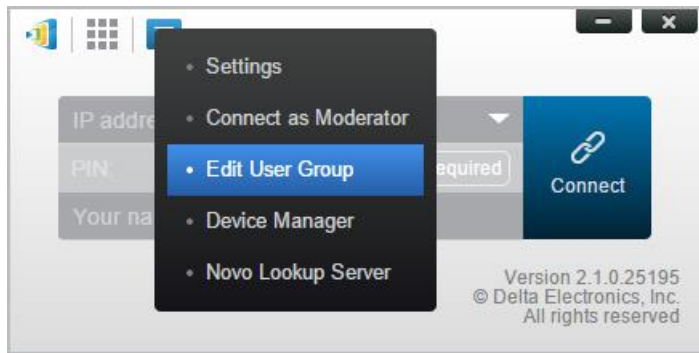

2. Click on button “Create” to add a new user group.

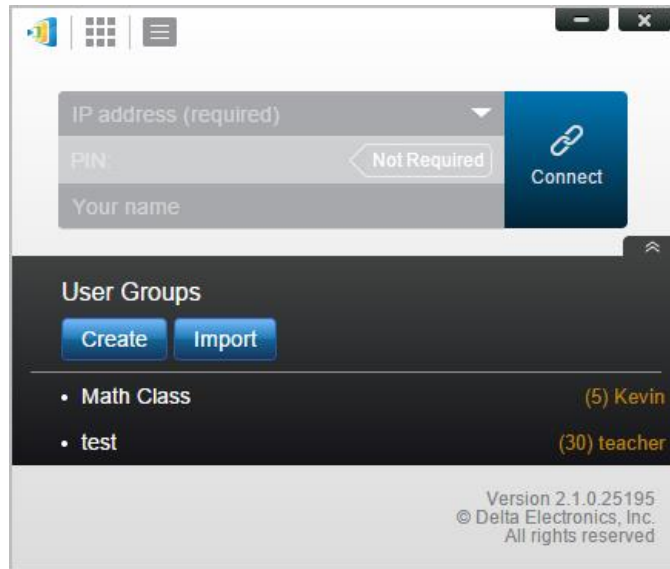

3. A new window, “Edit User Group”, will pop up. In this window, you will be able to edit group name, moderator (teacher) information, and members (students) information.

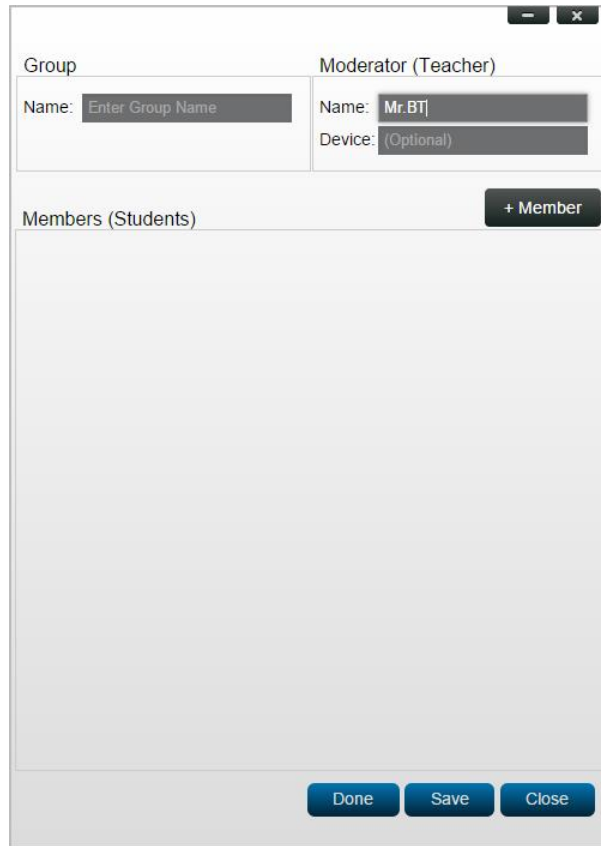



4. Once you have finished adding members to a group, click “Save” and “Done” to return to the “User Groups” list. This new group should appear on the list of user groups.

3.6.3 Manage an existing User Group file

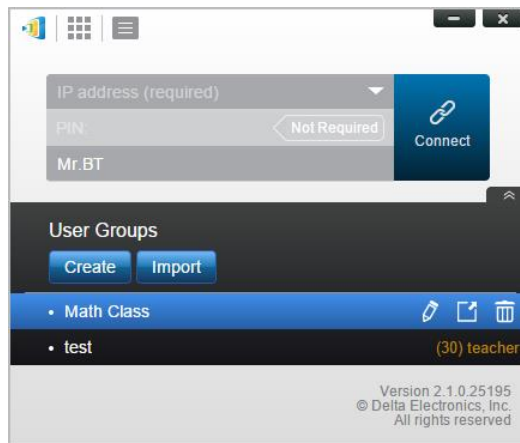
Click on one of the user groups and three action buttons will become visible on the right.



	(Edit)	Open “Edit User Group” window, allowing users to make changes.
	(Export)	Export a User Group as an XML file, which can be loaded to any mobile devices and other PC/Mac.
	(Delete)	Delete a User Group

3.6.4 Installing and operating the User Group file

(1) For PC/Mac

1. When you connect to a NovoPRO device, the Group will be displayed as “Not Selected”.

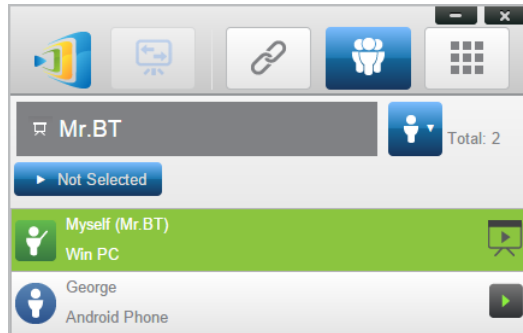

2. Click on “Not Selected” to display list of available groups, and then select the desired group and press button “OK”.

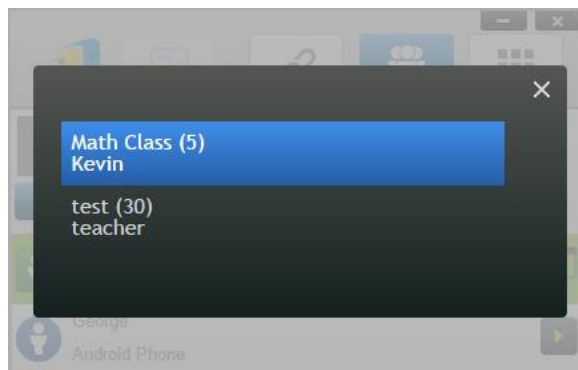

3. A user list will be displayed for the group you selected. Using tabs “All”, “Online”, and “Offline” are a quick way to sort users based on their status.

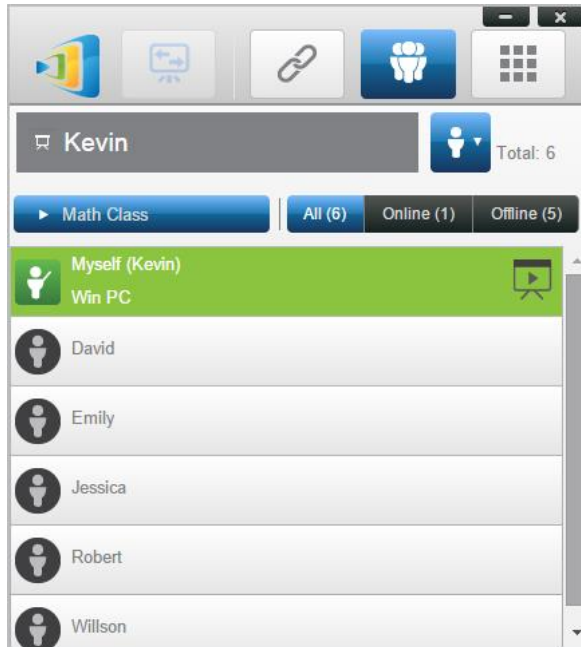

4. To de-select this group, click on icon .

(2) For iPad iPad installation

Launch iTunes application to copy the user group file (*.xml) to NovoPresenter App. (This User Group file is generated by using the Export function on the PC/Mac software.)

The following figure outlines the necessary steps to do so.

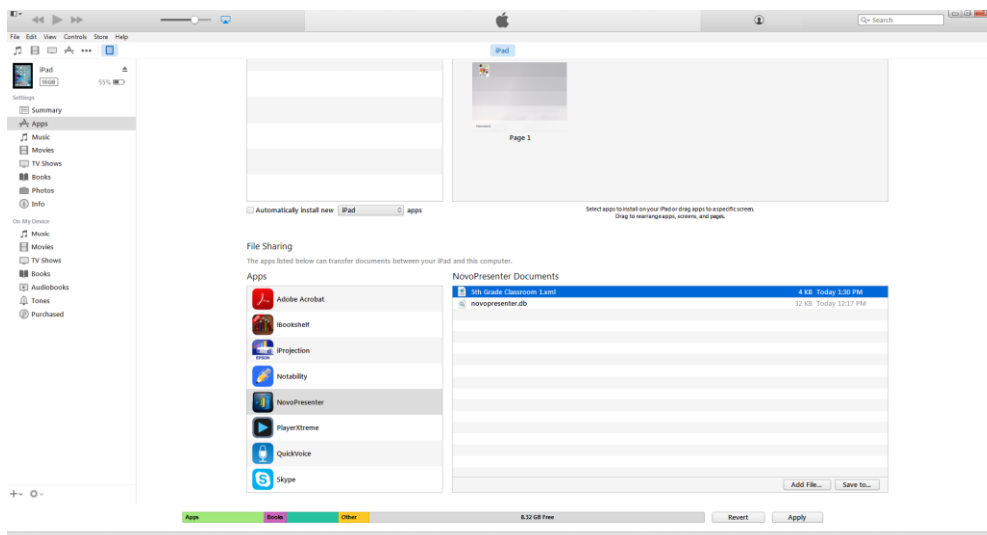

iPad Operation

1. Launch *NovoPresenter*. Go to “Settings” to Edit “User Groups”.

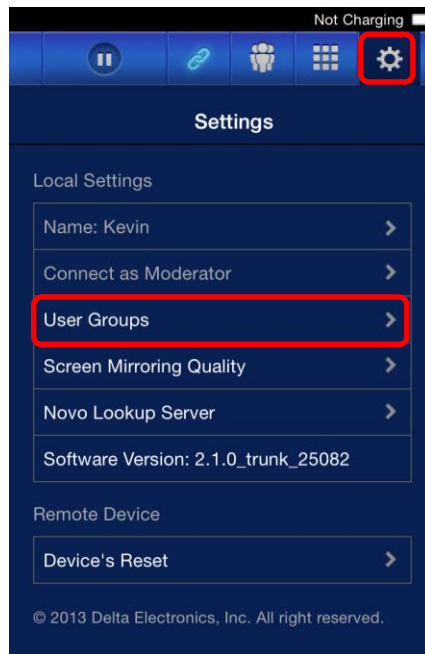

2. Click on button “Refresh” to import the User Group file you just copied to iPad.

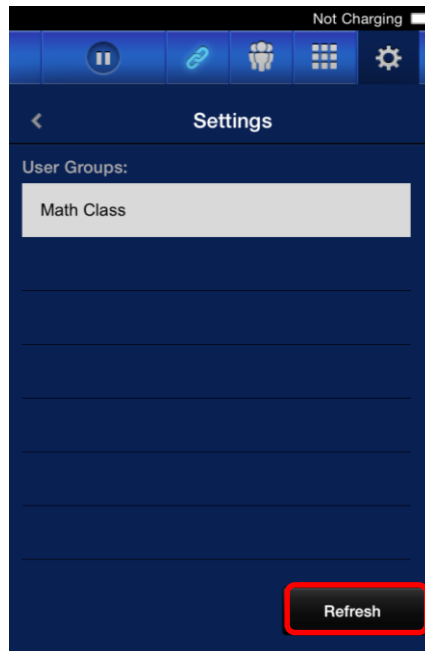

3. After connecting to the NovoPRO device, the Group will be displayed as “Not Selected”.

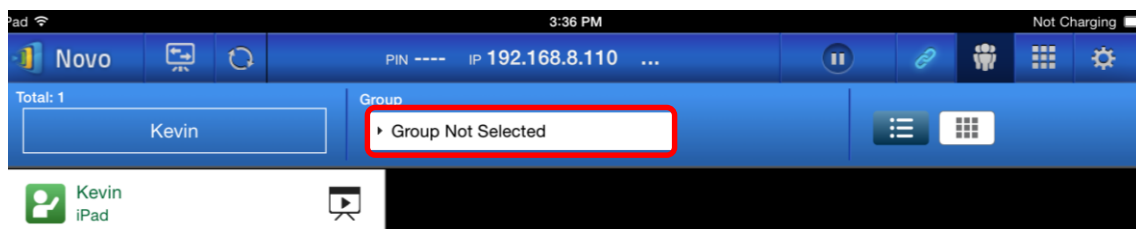

- Click on “Not Selected” to display list of available groups, and then select the desired group and press button “OK”.

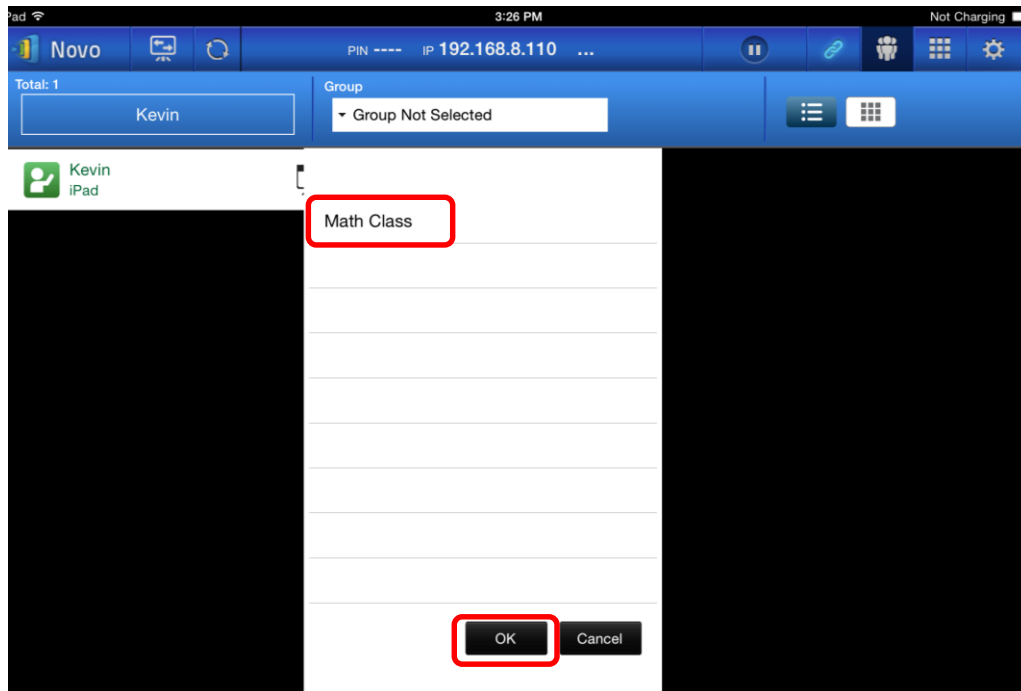

- A user list will be displayed for the group you selected. Using tabs “All”, “Online”, and “Offline” are a quick way to sort users based on their status.

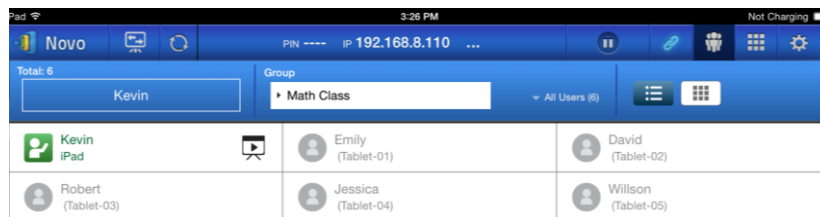

- To de-select this group, click on icon .

(3) For Android Device

Android installation

- Connect your Android tablet to your PC.
- Open your file manager and go to the NovoPresenter folder on your Android tablet. You will see a folder named “UserGroups”. Copy your XML file into this folder.

The rest of the operation is the same as it is for the iPad.

3.7 Video file and YouTube streaming

This feature allows you to smoothly stream videos from a variety of formats.

3.7.1 Application features

- The teacher or members of the class (if given permission by the moderator/teacher) can stream videos smoothly that are stored on local media such as computer hard drives and flash memory sticks (thumb drives).
- The teacher or members of the class (with moderator permission) can stream videos from YouTube video website. This function will only work if the NovoPRO unit is set to Wi-Fi mode and will not work in hotspot mode.

3.7.2 Streaming local video files

1. From the “Tools” menu, click on and launch the “Video & YouTube” tool.

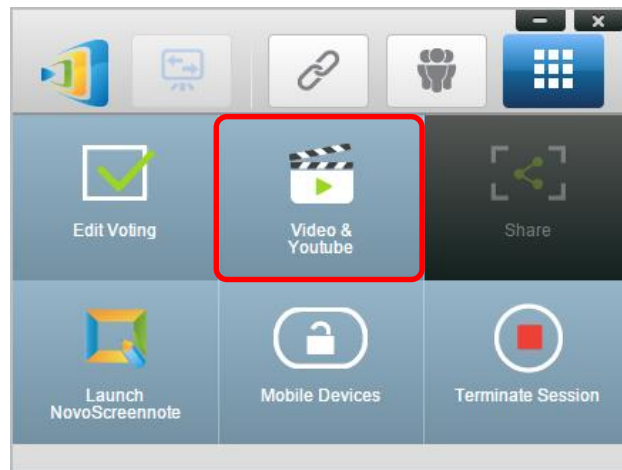

2. When the video player bar opens, click the browse button to locate the video file on your computer.

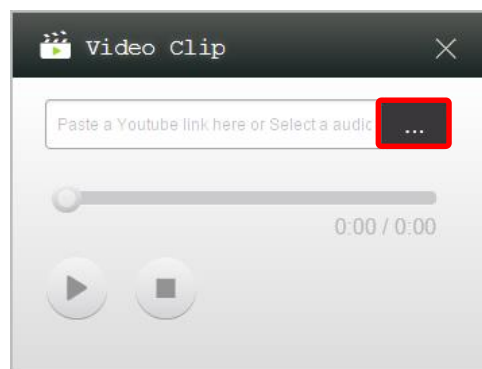

3. Select the video file and click “open.” The file should begin to play.

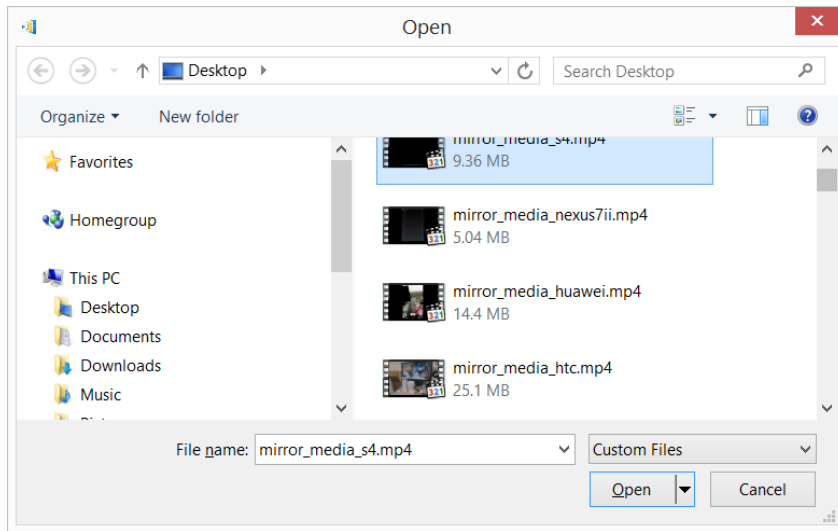

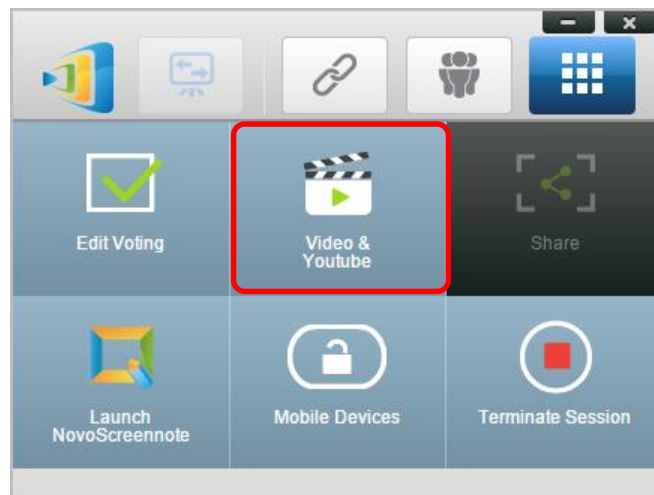

3.7.3 Streaming YouTube video

1. From the “Tools” menu, click on and launch the “Video & YouTube” tool.



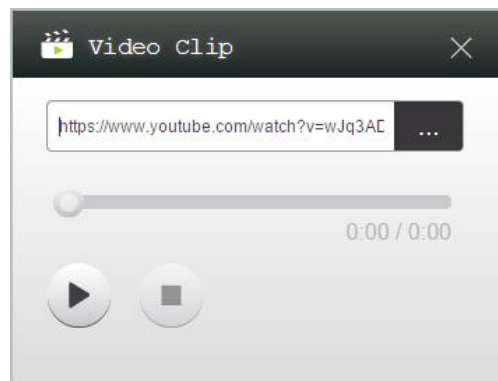

2. When the video player bar open, paste or type the URL for the YouTube video you wish to play in the window.



3. Press play arrow  and YouTube video should begin to play.

3.7.4 Video controls

1. You can play the video by clicking the play arrow .

2. You can stop the video by clicking the stop square .

3. You can skip forward or backward by moving



4. Advanced Features

4.1 Moderator credentials

The latest version of NovoPRO software (V1.6 and above) allows you to preset your moderator status while offline, so that you will always connect to a session as the moderator, even if you are not the first user to connect.

Overview

When using NovoPRO, the first connected user is assigned as the meeting moderator by default. However, this may not be the intended result in real world as the “real” moderator may not be the first user to join the session. New feature, “Moderator Credentials”, is designed to address this issue.

Here is how it works.

1. Moderator Credentials, consisting of a list of moderators and the corresponding passwords, are stored on NovoPRO units. (Moderator Credentials are managed via software Remote Manager.)
2. When a user device connects to a NovoPRO unit, the user device send its moderator password (if any) to the NovoConenct unit. If the password matches the one stored on the NovoPRO unit, the user device will be assigned as the moderator, regardless it is the first device to connect or not.

The picture below illustrates the process. The remaining sections describe how to configure and use this feature

Setting up Moderator Credentials in Remote Manager

1. Connect to your NovoPRO device via Remote Manager



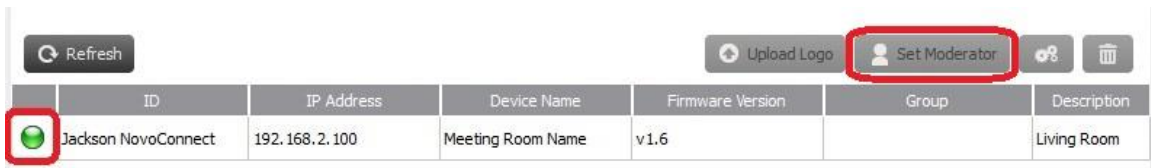

2. Make sure your NovoPRO device is online (the connection indicator is green).
3. Click the “Set Moderator” tab.

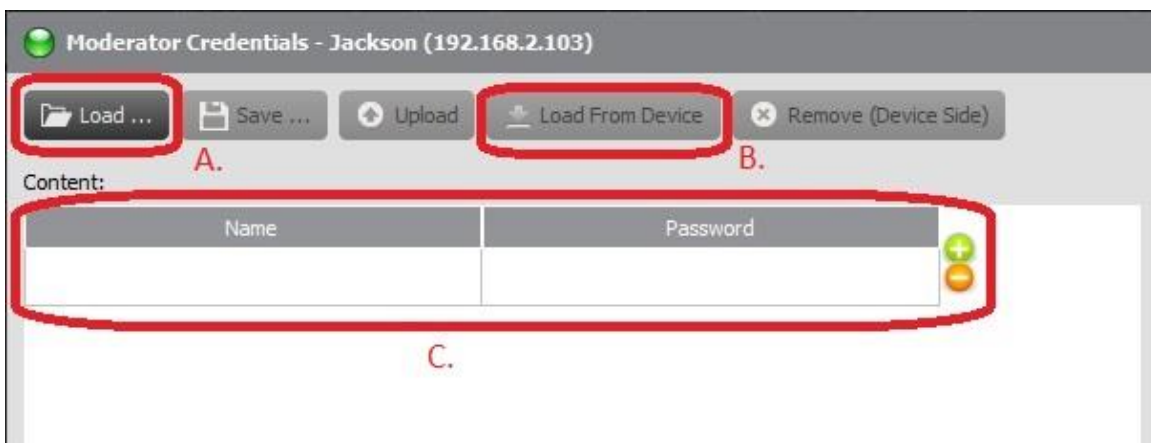

4. There are three ways to add data when setting up the moderator credentials:
 - A. Click the “Load” tab to import data from an existing file.
 - B. Click “Load from Device” to import from another device.
 - C. Input data manually by entering the moderator name and password in the “Content” windows.



5. **To import from a file:** Click “Load” to locate file. This will open a file manager window. Select a file with the “.ncmc” file extension and click “OK”.
6. **To load from a device:** Click the “Load from Device” tab. The warning “Do you want to save changes?” will pop up. Click “OK” to begin the file download.
7. **To input new data manually:** Type a new moderator name and password in the designated windows. Click the   buttons to add or remove moderator windows.
8. Once you have input the moderator data, upload the moderator file by clicking “upload”. Once the file has uploaded, click the “Go Back” button.

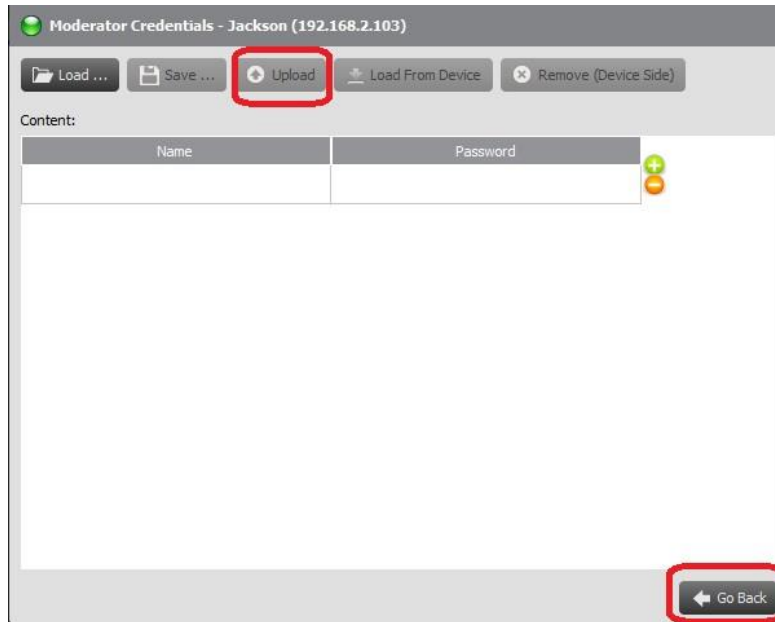

Setting up Moderator Credential status in NovoPresenter

1. To enable Moderator Credentials while offline, select the "Settings" tab in the upper right of the screen. Tap "Connect as Moderator" to open the setup tab. The default setting is disabled.

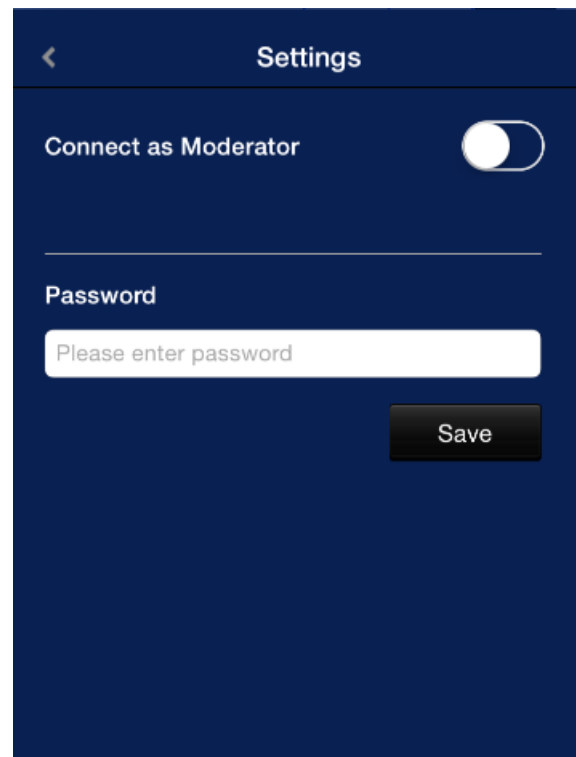
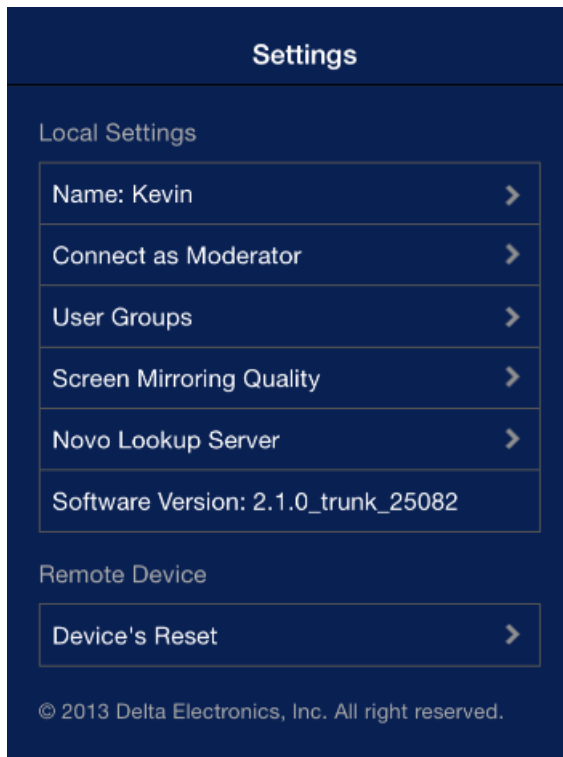

2. To enable Moderator Credentials, click the check box next to "Connect as Moderator" and enter a password into the "Change password" box.

3. Note, if you check the “Connect as Moderator box without entering a password, a  will appear next “Connect as Moderator” tab showing that the feature is enabled, but you have not entered a password.

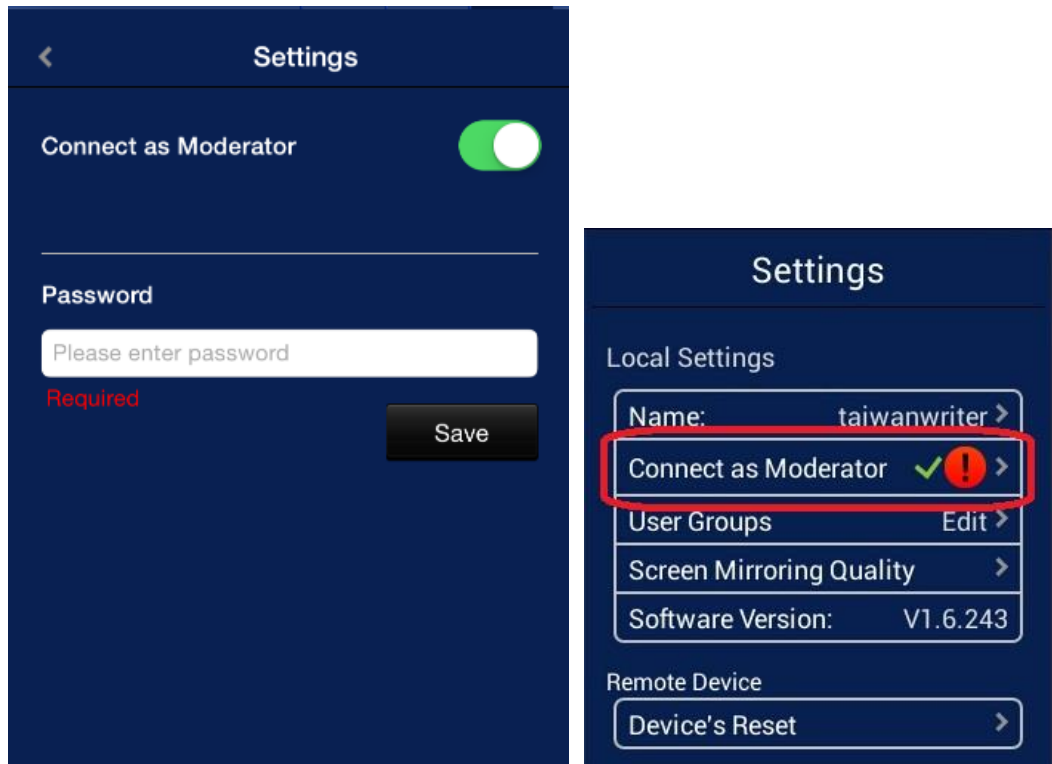

4. When Moderator Credentials have been enabled correctly, a single check will appear next to “Connect as Moderator.”



4.2 File sharing

Moderator can share files with all participants and participant can share with moderator.

This NovoPRO DesktopStreamer and NovoPresenter feature is available in version 1.6 and above for both the Corporate and Education editions. It allows session hosts (moderators) and participants to share files and screenshots between their devices.

4.2.1 Opening File Sharing in NovoPRO DesktopStreamer Windows/Mac PC

1. To open the File Sharing feature, click the tools tab. If you have recently upgraded from an older version of your software, you will notice that some new features have been added to your tool tab. The File Sharing tool is labeled “Share”.

Note: The file sharing button will only be illuminated when there is at least one other participant connected to the session besides the host (moderator).

2. Clicking on this button will bring up three options
 - a. Open “GroupShare” Folder: This is the default folder at “:\Users\\GroupShare”
 - b. Share File: This will bring up a file browser for users to select the file for sharing.
 - c. Send Desktop Screen: This will send the current desktop screenshot for sharing.

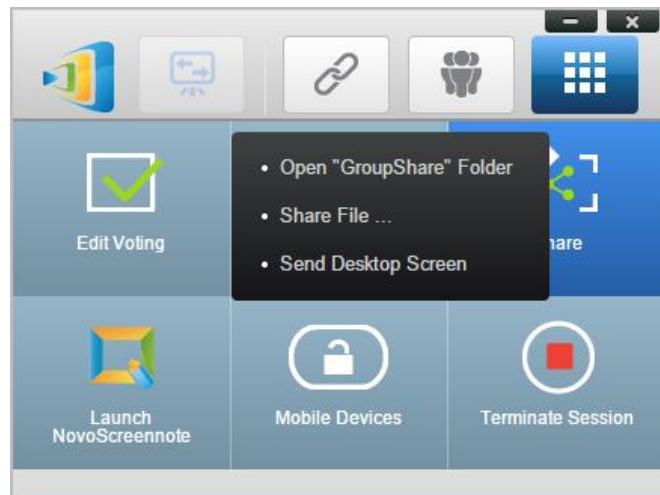

4.2.2 Using File Sharing to share a file with participants

1. To share a file in the GroupShare folder, select the “Share” function from the tools tab.

2. When the pop-up menu appears, select “Share File.” This opens the file manager window. Go to the “GroupShare” folder and select a file to share. A box will pop up to ask if you are sure you want to send the file. Select “Yes” to begin sending or “No” to cancel.
3. If you are sending more than one file at a time, a box will pop up warning “Current Transfer Is Still On-Going.” You will be asked if you want to abort the current transfer and send the new file instead.

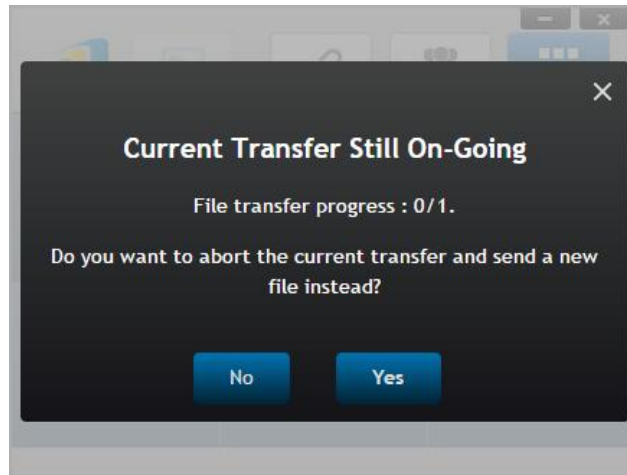

4. Selecting “No” will take you back to the previous step. Selecting “Yes” will cancel the current transfer and open the GroupShare folder, allowing you to select a new file. As before, a box will pop up to ask you are sure you want to send the file. Select “Yes” to begin sending or “No” to cancel.

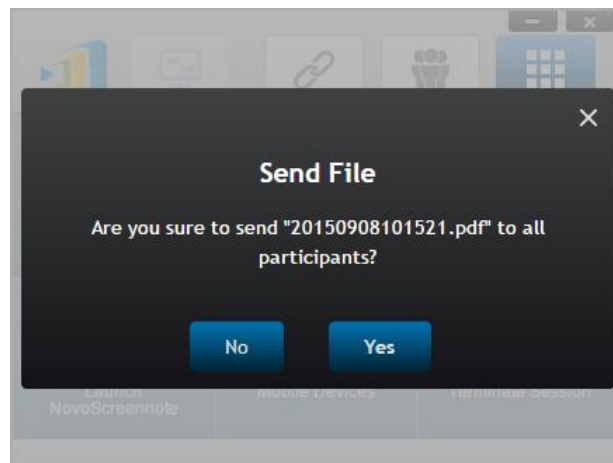

5. If you select “No” or 5 seconds pass without any response, a message will pop up and show system is busy and you will return to the DesktopStreamer tool window.

6. When a transfer is active, the  will appear next to the “Share” tool button, showing the transfer is in progress. A progress window will also appear showing the progress of the files being shared to the participant’s device. The progress window displays the percentage of the file that has

been transferred as well as the number of other recipients that have received files (in this example 0 of 30 participants).

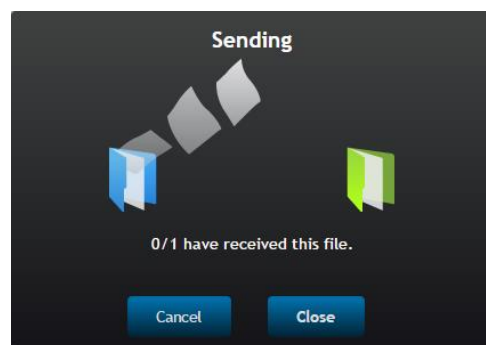
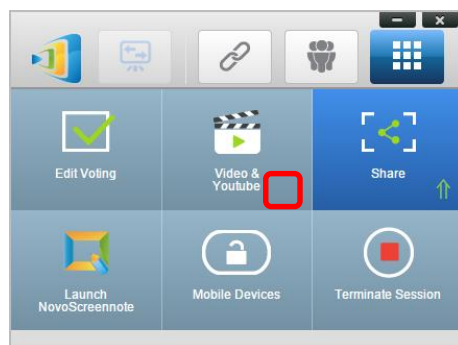

7. During the transfer, a “Cancel” and “Close” button will be displayed at the bottom of the status window. Clicking “Close” will continue the transfer in the background. “Cancel” will end the transfer and you will return to the DesktopStreamer tool window. When the file transfer is complete, you will return to the DesktopStreamer tool window.

4.2.3 Using File Sharing to share a desktop screenshot PC

1. Sharing a desktop screenshot is similar to sharing a file, but you do not need to select a file. Click the “Share” tool and select “Send Desktop Screen” from the pop-up menu. A dialog box will open displaying the screenshot and asking you to confirm “Are you sure you want to send this screen shot to all participants?”

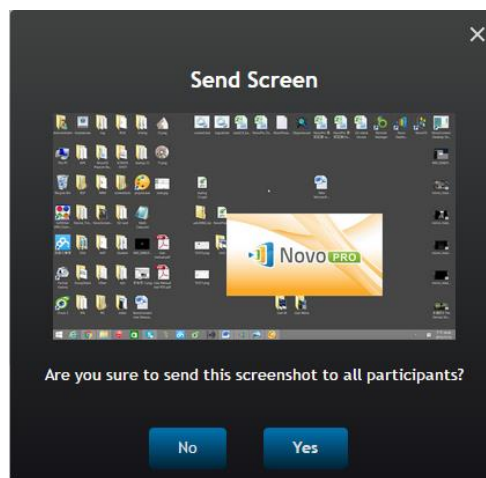
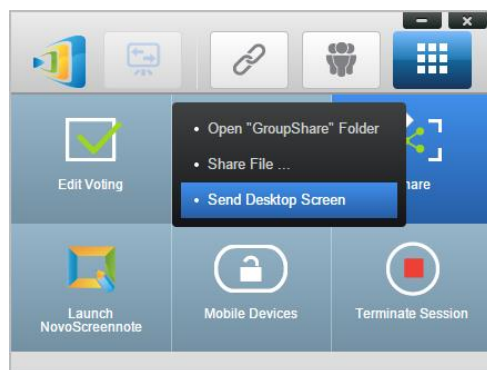

2. If you select “Yes,” the screen shot will be sent to the participants and a copy will be saved to your GroupShare folder.

4.2.4 Receiving a file to your PC with NovoPRO DesktopStreamer

1. When you are sent a file from a session participant you will receive a pop-up notice. Click either “OK” to close the message or “Open Folder” to go to the GroupShare folder to view the file.
2. Note: The file will be given a file name format will be “sender-name_original-filename”.

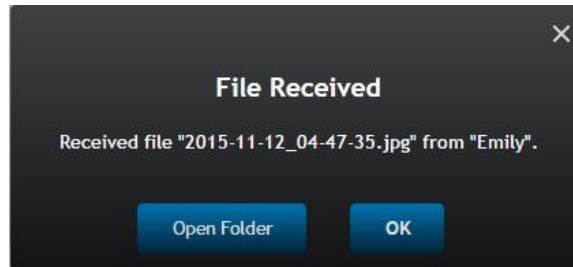

4.2.5 Troubleshooting and rules to remember with DesktopStreamer PC

1. If a file transfer is in progress when you are attempting to send a new file you will receive the message: “System is busy. Please try again later.”
2. If you attempt to share a file and no other users are logged into the session, the “Share” tool button will not be illuminated and you will receive the message: “No recipient; Nobody else is online.” (can’t touch the “share” button.)

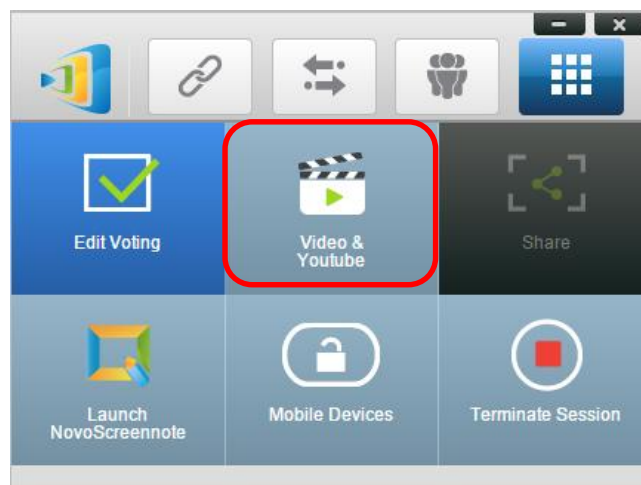



3. If you attempted share a file that is larger than 3 MB, you will received the message: “Failed to send; The file exceeds the size lime (3 MB).” File sharing cannot handle files larger than 3 MB.

4.2.6 How to send and receive files using NovoPresenter

Note: Make sure you have installed the latest version of NovoPresenter on your Android or iOS device (version 1.6 or later).

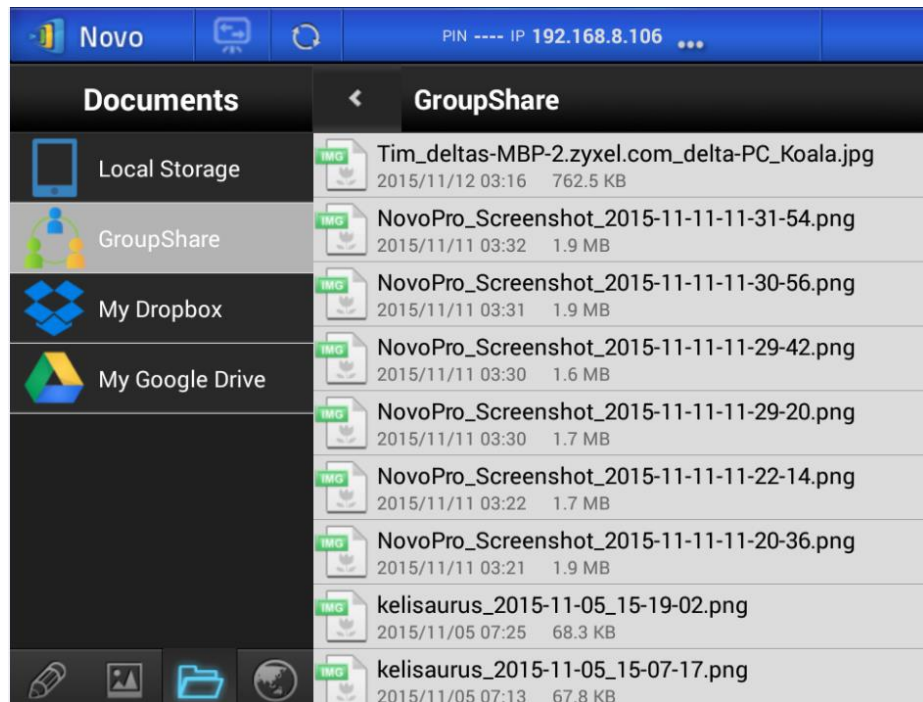
1. After updating, NovoPresenter will create a new folder on your device called “GroupShare”. This folder can be located by tapping the file folder tab in the lower left corner of the home screen. This folder is for receiving shared files.



2. To share a file, first navigate to the folder where the file is stored. Tap the GroupShare tab from the Documents screen to access files in the group share folder. Tap Local Storage for files stored elsewhere on your device. For video and images in your Gallery, tap the Gallery button  at the bottom of the page.
3. If you are the moderator/teacher of the session, you may send a file to all participants. Locate the files and press and hold the screen over the file until the “Send to All” button pops up. Tap the button to begin sending the file.

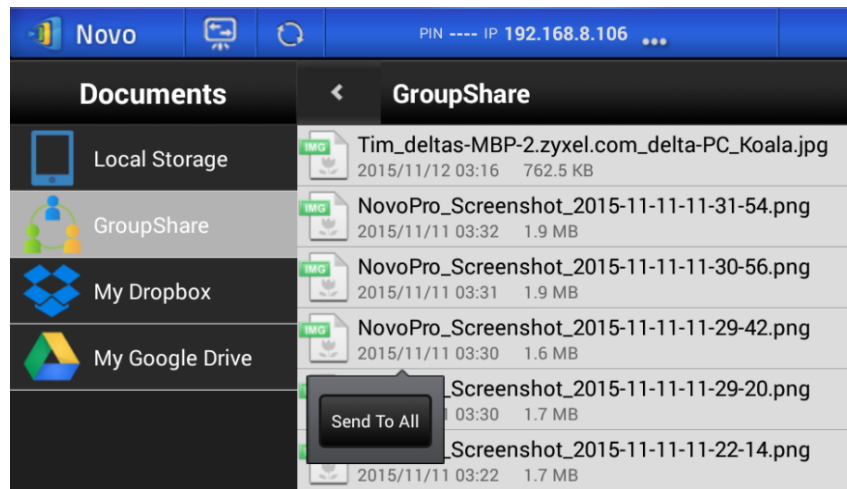

4. If you are a participant in the session, you may send a file to the moderator. Locate the files and press and hold the screen over the file until the “Send to Moderator” button pops up. Tap the button to begin sending the file.

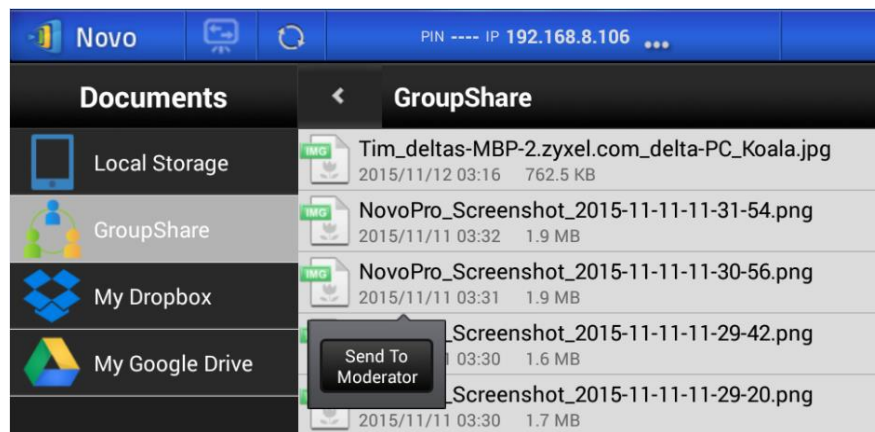

5. A confirmation box will open asking you to confirm the transfer. Tap “Yes” to continue or “No” to cancel.
6. When sending a file the system will check to make sure that a file is not already in the process of being sent. If a file is already being transferred, an error message will pop up saying “The System is Busy.” You will have to resend the file when the prior transfer is complete.
7. If no other files are currently being transferred, a progress box will pop up to showing that the transfer is proceeding. You can cancel the transfer by tapping “Cancel” or tap “Close” to close progress window and continue transferring in the background.

4.2.7 Send a screenshot with Send Screen in NovoPresenter PC

1. To send a screenshot in NovoPresenter, open the tool bar and select the “Send Screen” tool.

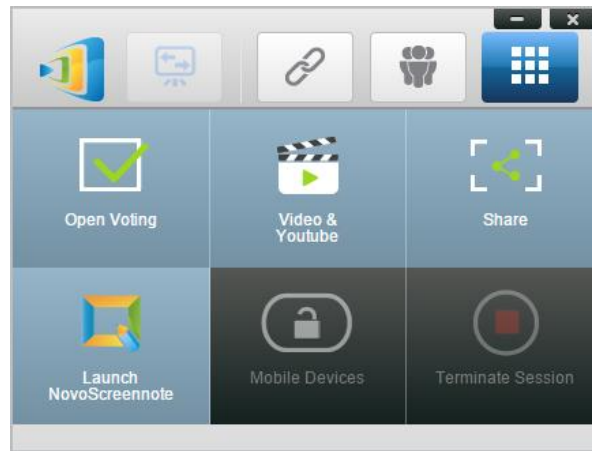

2. A dialog box will pop up asking, “Are you sure to send this screenshot to (moderator name/all participants).” The recipient will depend on whether you are the moderator/teacher or a participant. Select “Yes” to begin the transfer or “No” to cancel.

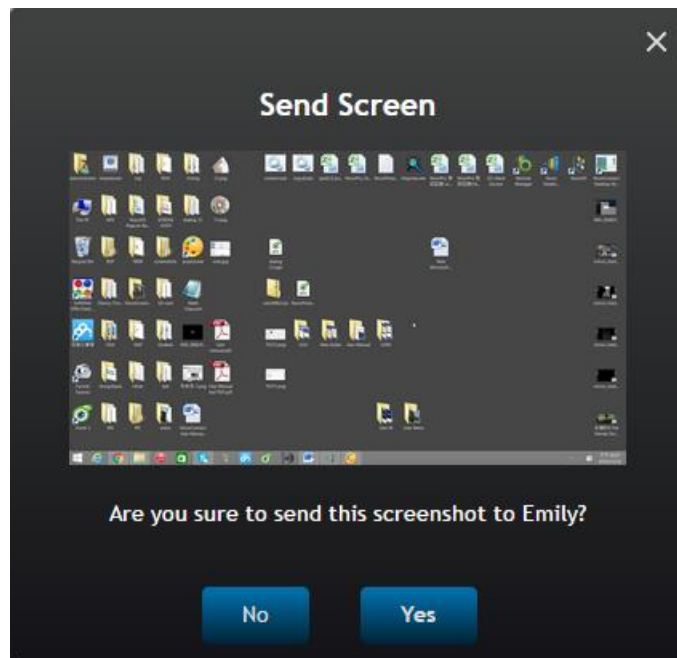

3. If no other transfer is in progress, Send Screen will appear as it does any other file sharing process.

4.2.8 Receiving files in NovoPresenter

1. After receiving a file in NovoPresenter, a notification box will pop up alerting you “File Received”. You will be given the choice of opening and viewing the file or closing the notification and viewing the file later.

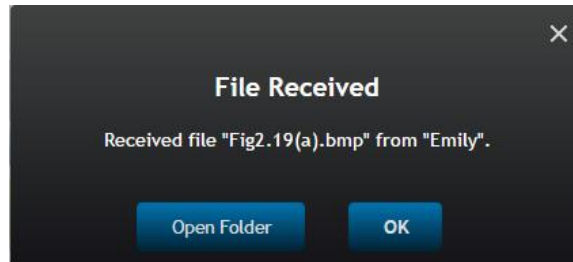

2. The file name format will be “sender-name_original-filename”.

4.2.9 Troubleshooting and rules to remember with NovoPresenter PC

1. If you attempt to share a file and no other users are logged into the session, you will receive the message: “No recipient. Nobody else is online.”

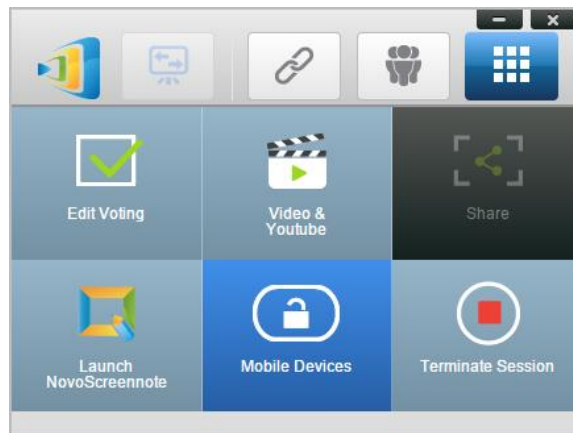

2. The moderator and all participants must be using the latest version (1.6 or later) of either NovoPresenter or NovoPRO DesktopStreamer software for File Sharing to work properly. The NovoPRO device must also be upgraded to version 1.6 or later firmware. If this is not the case, you will receive an error message stating, “To enable this feature, upgrade your NovoPRO device firmware to version 1.6 or above.”
3. Files transferred with File Sharing must be no larger than 3 MB. If you attempt to share a larger file, you will receive the following error message: “Failed to Send; file exceeds size limit (3 MB).”

4.3 Remote manager

Manage multiple NovoPRO devices from a single PC

Remote manager is a stand-alone Windows/Mac application that allows the settings of multiple NovoPRO devices to be managed from a single PC, making it ideal for corporations, schools or other large institutions.

4.3.1 Software setup

- (1) Download the installation package from the NovoPRO website.
- (2) Click on the installation package and follow the on-screen instructions.

4.3.2 Adding devices

1. To add a new device to the device list, click on “+ Device” button at the top of the screen.



2. This will open the “Create New Device” window. Enter the device’s ID, description (such as location), and IP address. You can also select a group (optional) from the group list pull-down menu. Click “OK” to complete adding the new device.



Create New Device

ID: Jackson NovoConnect

Description: Main Meeting Room

IP Address: 192.168.2.100

Group: [Pull-down menu]

OK Cancel

3. When the new device is successfully added it will appear in the device list.
4. If the device is currently connected, the connection indicator will be green. Otherwise, it is red.

Connected

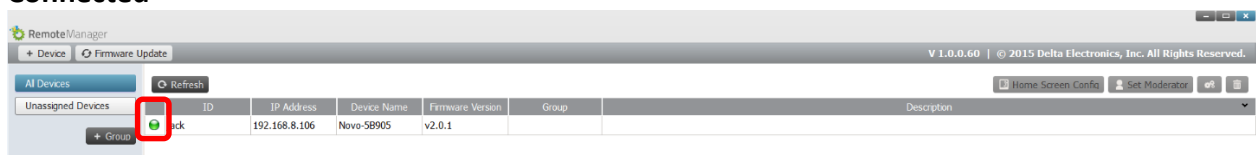

Disconnected

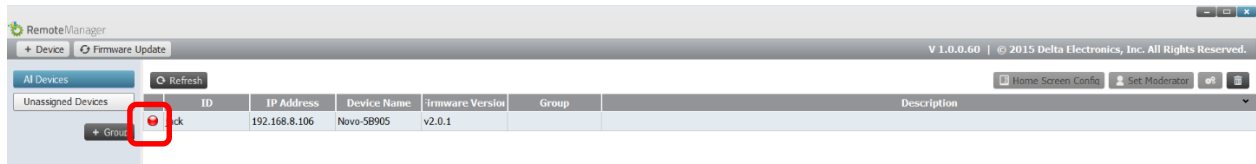

4.3.3 Removing a device

1. To remove a device from the device list, click on the device you wish to remove from the list then click the  icon.
2. A pop-up box will ask "Are you sure to delete." Click "Yes" to confirm or "No" to cancel.

4.3.4 Refreshing device list

1. To refresh the list of devices in Remote Manager, click the "Refresh" in the upper left of the program screen.



4.3.5 Managing device settings

1. By selecting a device and clicking the device settings button  you will be taken to the device settings management screen. From here you will be able to remotely view and/or preset the settings for each NovoPRO device on your network. You will be able to edit settings for Device Name, Display Setting, Language, and Device Password. You can view setting/status for Model, Edition, App Version, Build Version, Wi-Fi Mode, SSID, Wi-Fi IP, and LAN IP.

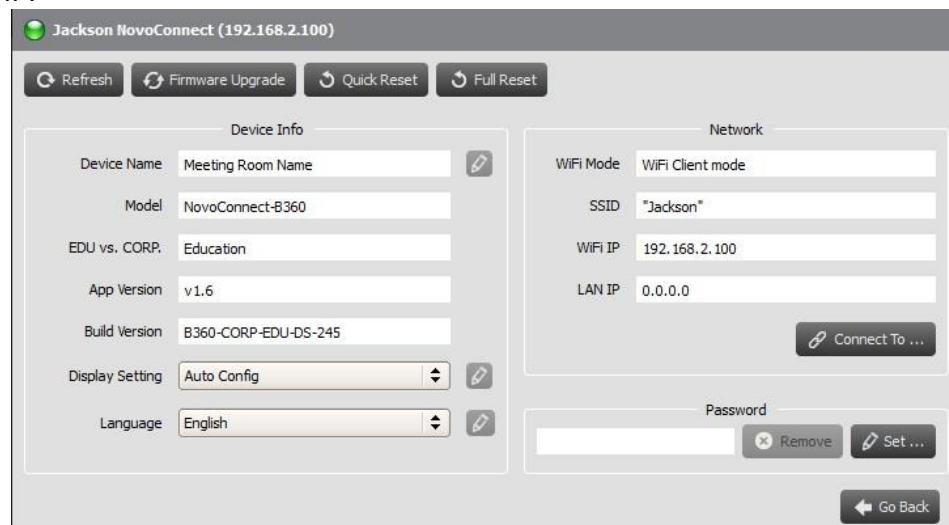

2. To edit the modifiable settings, select windows or menus next to the edit symbol .
3. Click “Refresh” to display latest settings.
4. Click “Firmware Upgrade” to check for the latest device firmware. If an upgrade package is available, the upgrade process will be triggered.
5. Click “Quick Reset” to reset the application.
6. Click “Full Reset” to reboot the device.
7. Click “Go Back” to return to the main screen.

4.3.6 Uploading a logo

1. To upload a custom logo to a device, select the device and click “Upload Logo.”

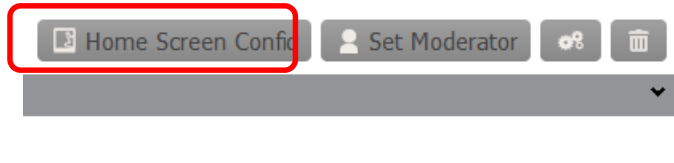

2. This will open the Logo Upload screen from which you can select, crop, and resize your logo.
3. Click “Open” to select an image file.

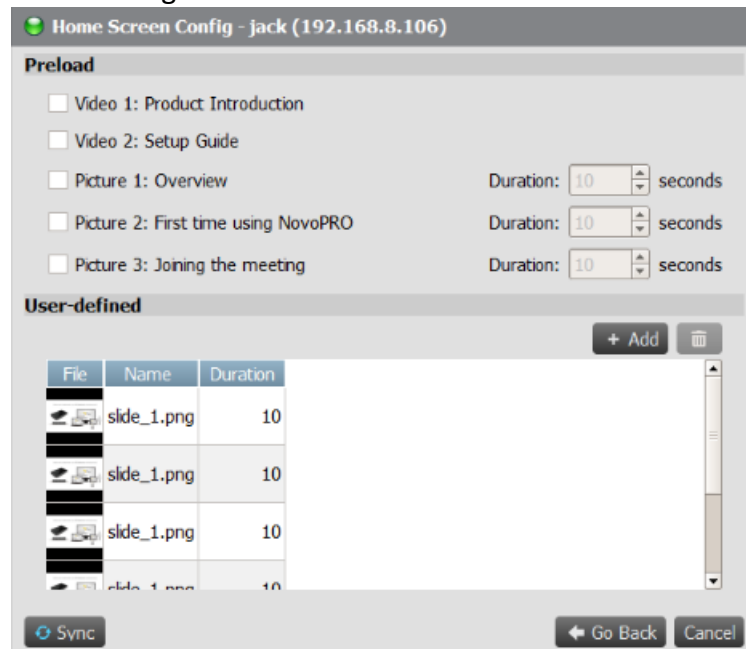

4. Select either “Cropped” or “Full Sized.” When “Cropped” is selected, drag the cropping box to trim the photo to the desired size. The resized image and dimensions will be displayed in the “Target” window. Click “Full Sized” to undo your changes.
5. Click “Save” to save the new logo image locally or “Upload” to send it to the device.

4.3.7 Updating firmware

1. Remote Manager allows you to check and update the firmware of multiple NovoPRO devices on your network at once.
2. Click “Firmware Update” on the home screen to go the Firmware Update screen.

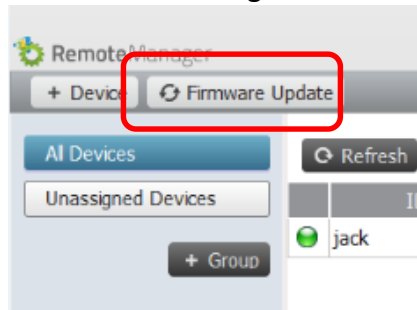

3. A list of connect devices will be displayed with check boxes in the left column. Select the device or devices you wish to check for updates, or click “Select All” to check all devices on the list. Click “Unselect All” to remove all checks.



4. Once you have selected the devices to update, click “Update Now.”

4.3.8 Setting moderator credentials

1. To set moderator credentials for a device, select the device from the device list and click “Set Moderator.”



2. This will open the Moderator Credentials window. Note: For changes to take effect, make sure the green connection indicator is lit in the upper left of the screen.



3. Enter the moderator name and password in the corresponding windows.



4. Use the  buttons to add or delete moderators from the list.
5. Click "Save" to save the moderator credential file to the local PC.
6. Click "Upload" to upload the new moderator credential file to the device.
7. Click "Load from Device" to download a file saved on the device.
8. Click "Load" to load a moderator credential file stored on local storage.
9. Click "Remove (Device Side)" to remove moderator credentials currently stored on device.

Note: Moderator credential files will be stored in the XXXX.NCMC file format.

4.4 Responding with Voting (iOS, Android, Chromebook)

4.4.1 Answering Voting questions with Android phone and tablet

Voting allows Android users to respond to a teacher or moderator submitted questions.

1. Open Voting by selecting it from the Tools tab.

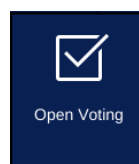

2. No question will appear until the moderator or teacher sends a question.
3. Once a question is sent, it will appear on the participant's screen. Select the correct answer and then the "Submit" button. If the question is open-ended, you can select an image file (.png format) from your device to submit as your answer.

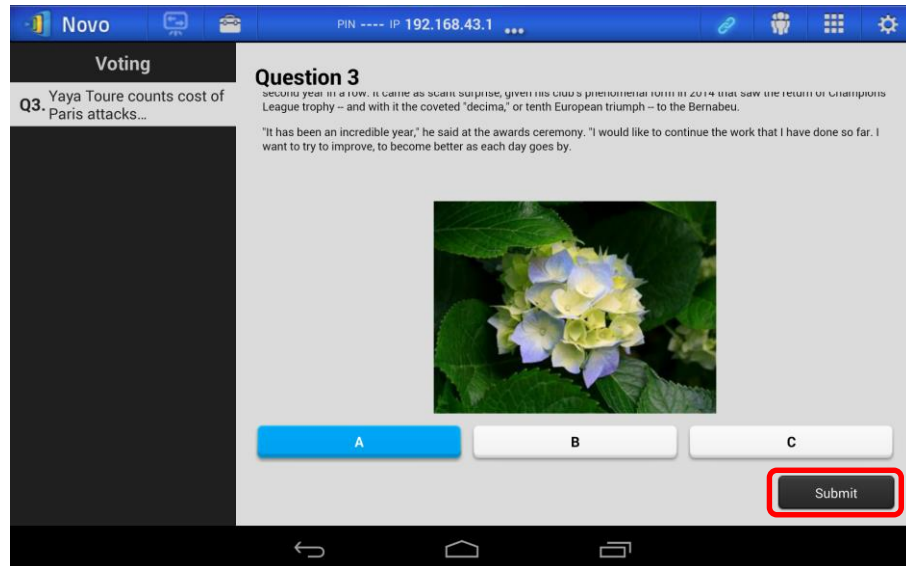

4. You will receive a confirmation message when your answer has been sent successfully.

4.4.2 Answering Voting questions in iOS (iPhone, iPad)

1. Open Voting by selecting it from the Tools tab.

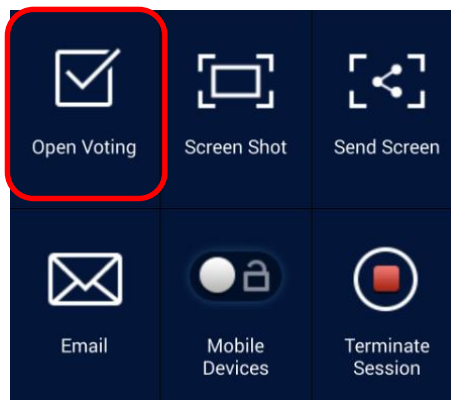

2. No question will appear until the moderator or teacher sends a question.
3. Once a question is sent, it will appear on the participant's screen. Select the correct answer and then the "Submit" button. If the question is open-ended, you can select an image file (.png format) from your device to submit as your answer.

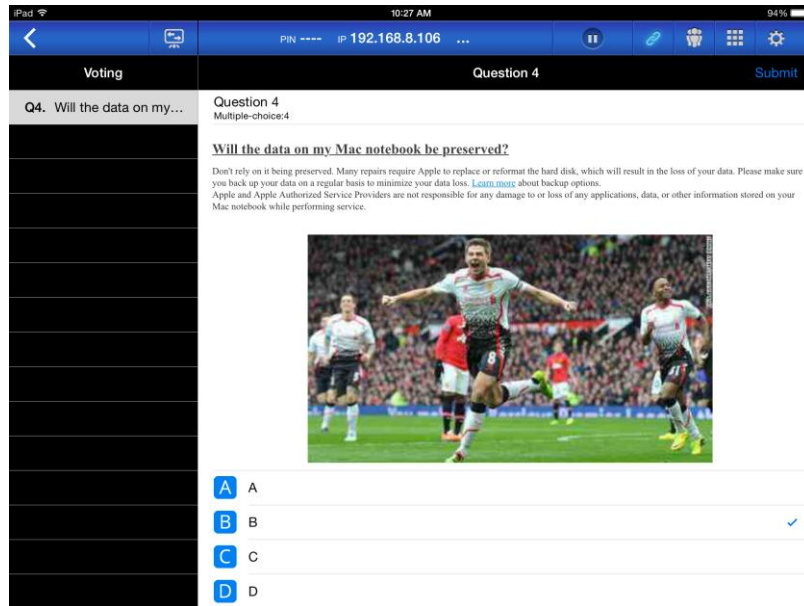

4. You will receive a confirmation message when your answer has been sent successfully.

4.4.3 Answering Voting questions with Chromebook

Voting allows Chromebook users to respond to a teacher or moderator submitted questions.

1. Open Voting by selecting it from the Tools tab.

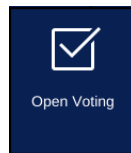

2. No question will appear until the moderator or teacher sends a question.
3. Once a question is sent, it will appear on the participant's screen. Select the correct answer and then click the "Submit" button. If the question is open-ended, you can select an image file (.png format) from your device to submit as your answer.

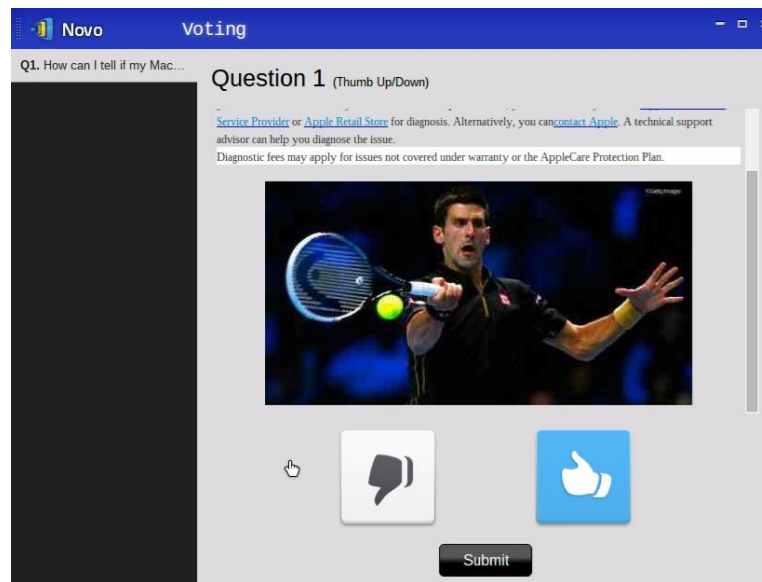

4. You will receive a confirmation message when your answer has been sent successfully.

4.5 iOS device mirroring

All participants in a meeting using Apple iOS devices can mirror their screens by using NovoPro's Airplay service. No App is required to use this function.

1. Connect your Apple iOS device to the same network where your NovoPro device stays.
2. Swipe up from the bottom of the iPad or iPhone to show the Control Center.

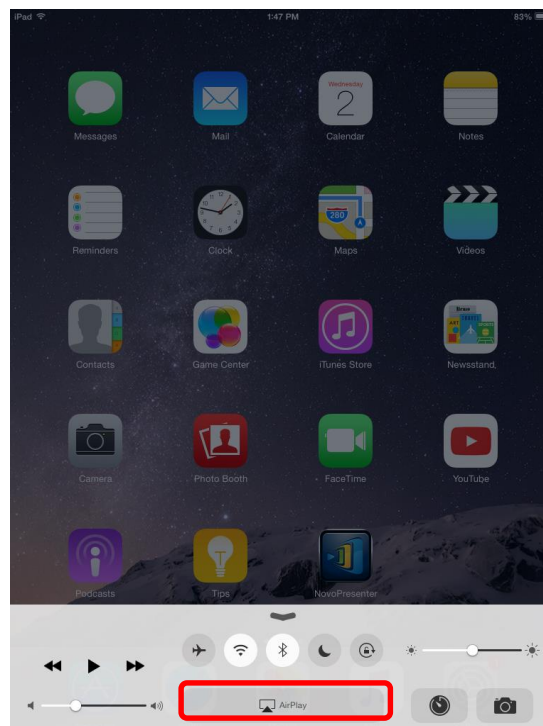

3. Click AirPlay and select NovoPro's AirPlay device name. By default NovoPro's AirPlay device is named as "Novo-XXXXX", where XXXXX is a device-generated combination of letters and numbers.

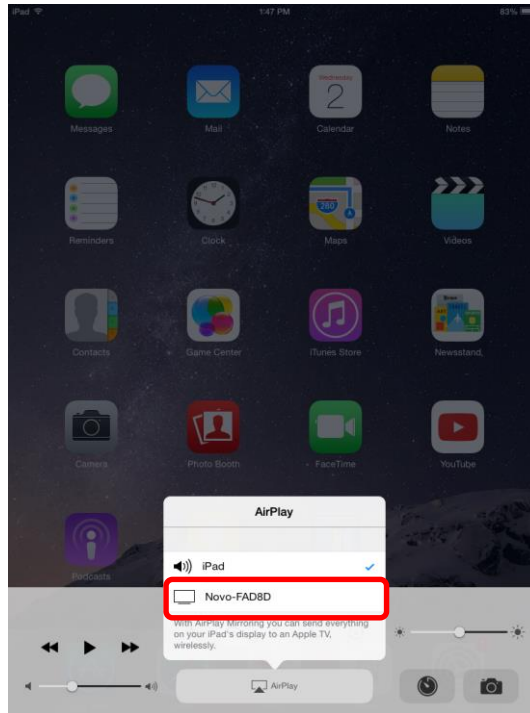

4. Then you should switch on "Mirroring" option, and an "Airplay Password" prompt window pops up. Please enter 4-digit PIN code, which you can get from NovoPro's home screen (illustrated below). After the correct PIN is entered, your iPad or iPhone's whole screen will be mirrored to your projector or TV.

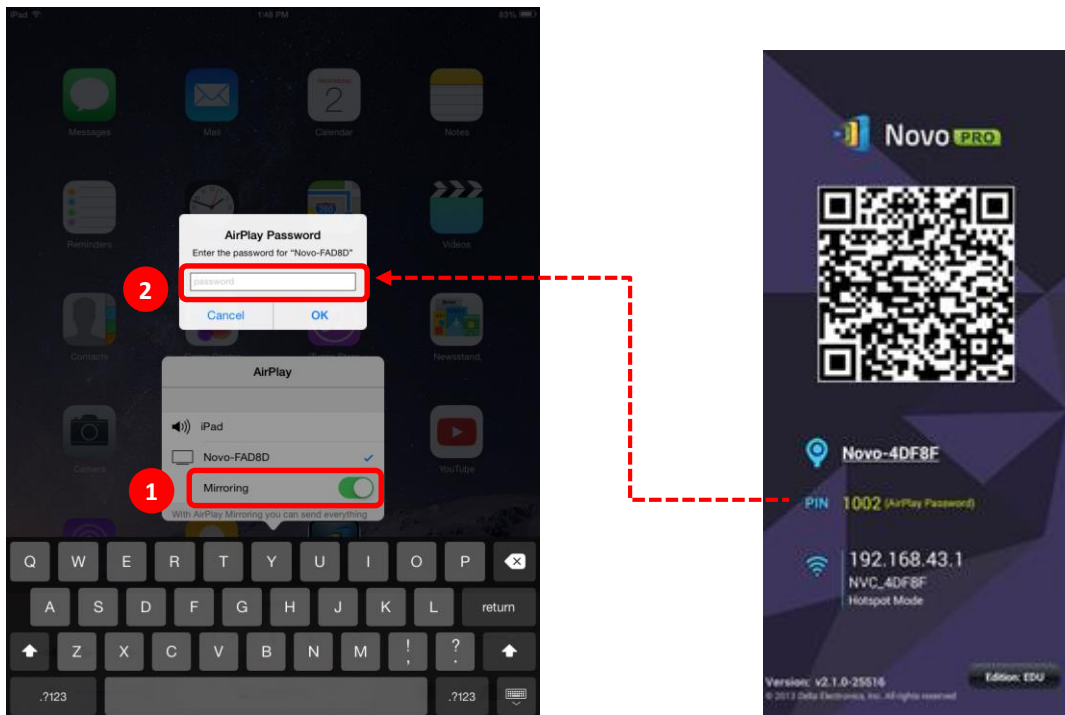

5. To stop mirroring your iOS device, you should swipe up from the bottom of the iPad or iPhone to show the Control Center. Tap “Novo-XXXXX” name, and then switch off mirroring function.

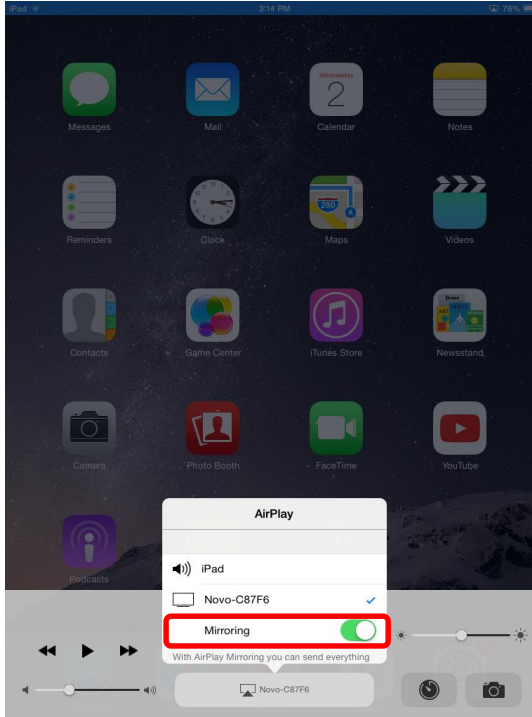

4.6 Android device mirroring

All participants in a meeting using Android tablets or phones can mirror their screens by using NovoPro’s Miracast service. No App is required to use this function.

Please note: the concreted operation steps might be different due to different Android OS releases or different customized Android builds. The following steps are illustrated using Google’s Nexus 7 Android tablet.

1. Connect your Android iOS tablet or phone to the same network where your NovoPro device stays.
2. Swipe down from the top of the Android device to show the Control Center, and then tap **Cast** button.

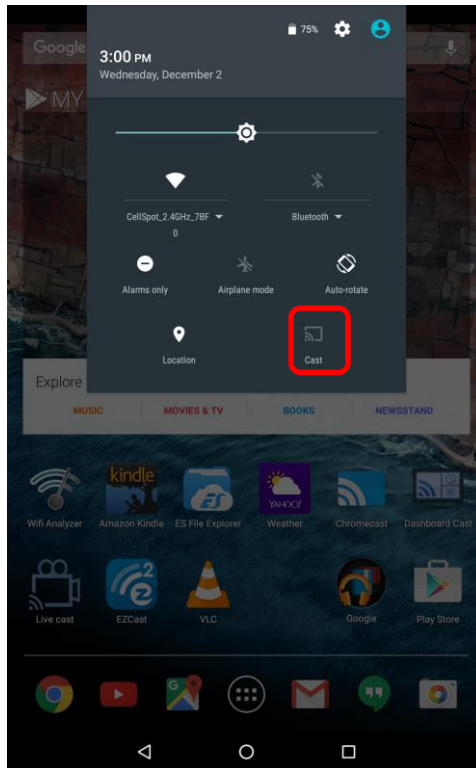

3. Here shows all devices you can cast your Android device to. If this is the first time you set up such a connection, you might not see any available device here. Please tap “MORE SETTINGS” to set up a new Miracast service device.

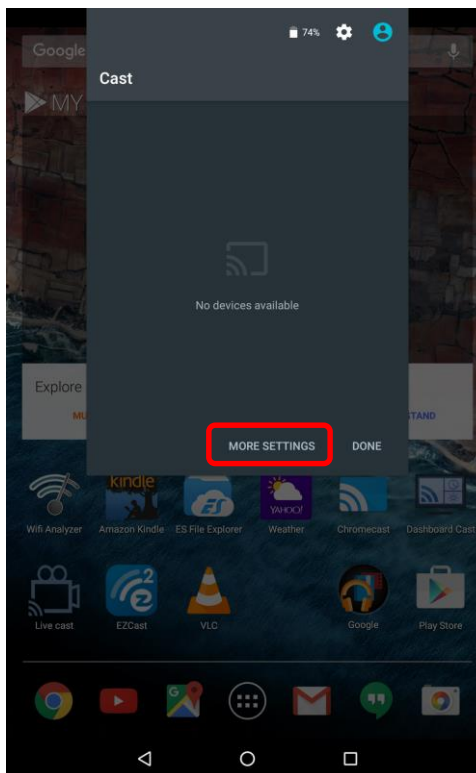

4. Here shows all available Miracast capable devices you can cast to. In this case, “Novo-C87F6” is a Miracast service device, and you tap on such a device name.

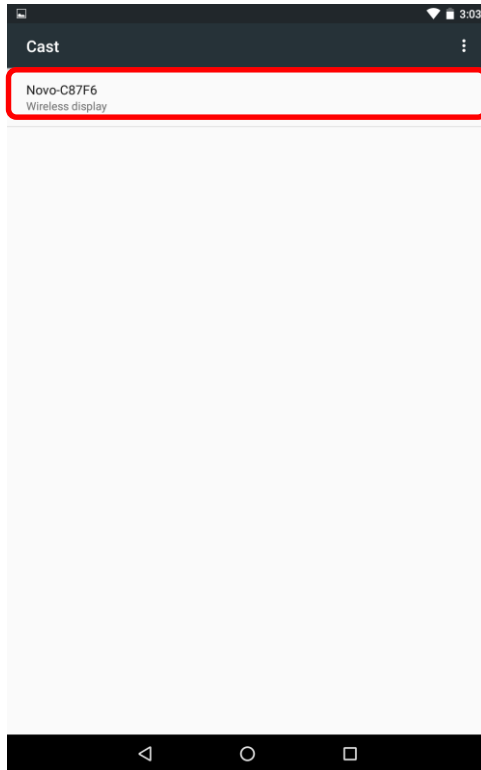

5. It shows your Android device is connecting to such a Miracast service device.

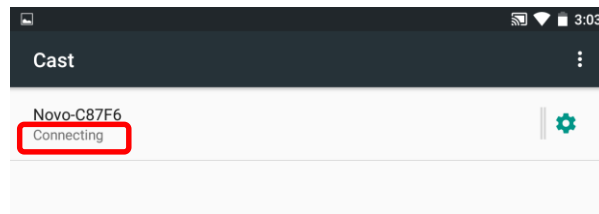

6. After a few seconds, if connection is successfully setup, it shows “**Connected**”. At this moment, your Android device full screen should have been mirrored to your projector or TV.

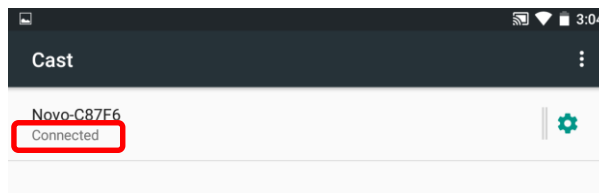

7. To stop mirroring, please swipe down from the top of the Android device to show the Control Center, and then tap **Cast** Icon. Pls note, here “Cast” wording is changed to the Miracast service device name.

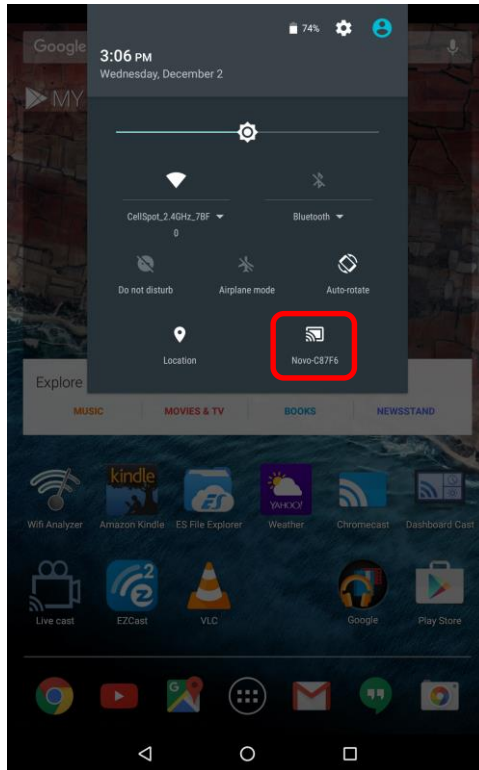

8. Tap  icon to finish disconnection.

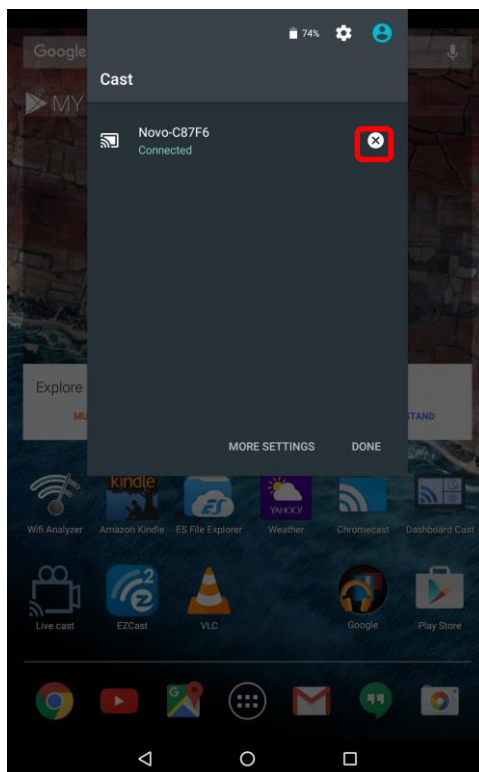

5. Device Configuration

5.1 Configure NovoPRO system locally

Remote Viewer is the application software on the NovoPRO device that hosts the presentation group. The main function of *Remote Viewer* is to manage and control all presentation sessions between the *participant* devices and the NovoPRO. In addition to presentation management, *Remote Viewer* supports the configuration of the following parameters on the NovoPRO device:

- Setup Guide
- Wi-Fi
- Display
- Settings
- Reset
- Presentation Group Name

Note: Following any clicking activity on the screen, the system bar  appears.

Click the back key  one or more times until the system bar disappears.

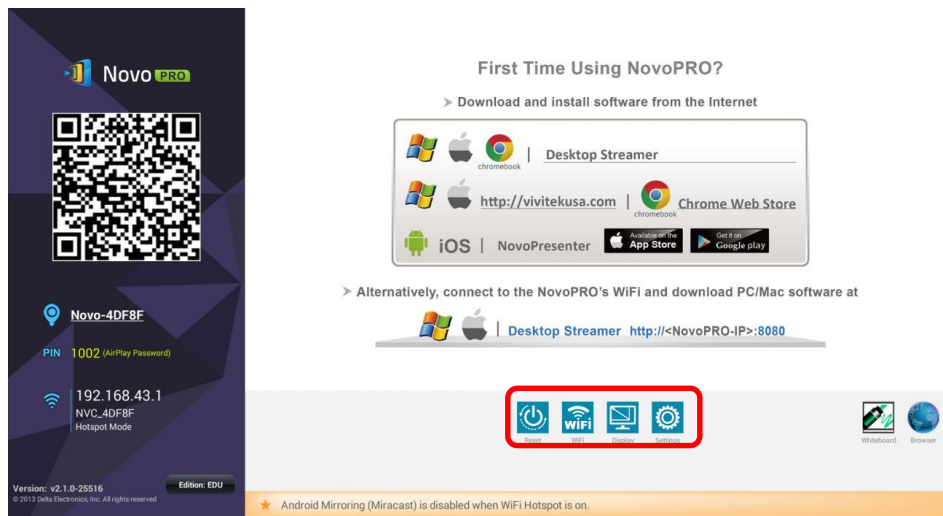

Please go to the NovoPRO home screen to locate the parameters. You will need a USB-based mouse to perform setting changes.

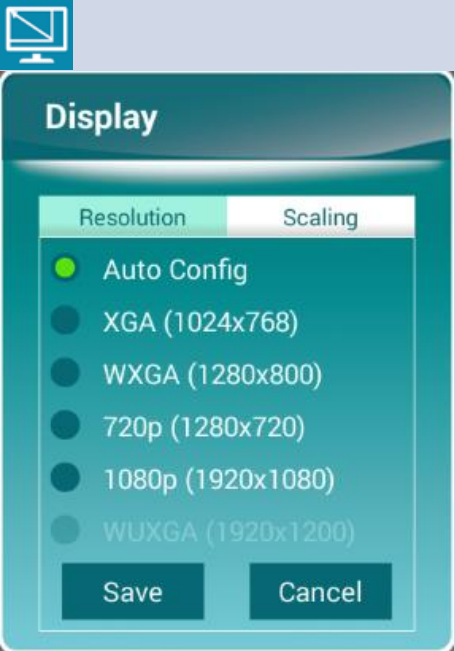
Function	Description				
	<p>Setup Guide and QR Code: The NovoPRO connection setup guide is initially selected when NovoPRO is first powered on. To show or hide this guide, click Setup Guide. For quick connection with iPad or Android tablets, the NovoPRO connection QR code is continuously displayed and updated on the lower right corner of the NovoPRO home screen. For more details regarding the use of this setup guide and the QR code, please refer to the section 1.2.2 The NovoPRO Home Screen earlier in this document.</p>				
	<p>Wi-Fi: Click the WiFi button to bring up the Wi-Fi configuration window. To use the NovoPRO as the Wi-Fi host, select “Enable WiFi Hotspot” and click Apply. To use an external router as the Wi-Fi host with Internet access, select “Connect to WiFi”; click Configure to bring up the relevant Android system menu. Enable Wi-Fi connection. Select the SSID of the external router. Enter the router’s password if needed. Click Connect.</p>				
	<p>Display: Click the Display button to bring up the <i>Select Display Output Format</i> window. Select one of the following screen resolutions (the <i>presenter’s</i>, Windows and Mac PC, will be automatically adjusted to match the selected option):</p> <table border="1" data-bbox="634 1113 1427 1354"> <tbody> <tr> <td data-bbox="634 1113 967 1197">Auto Config</td> <td data-bbox="967 1113 1427 1197">This setting automatically determines the optimal screen resolution.</td> </tr> <tr> <td data-bbox="634 1197 967 1354">XGA(1024x768) WXGA(1280x800) 720p (1280x720) 1080p (1920x1080)</td> <td data-bbox="967 1197 1427 1354">You can specify your desired display output resolution.</td> </tr> </tbody> </table> <p>Click Save to confirm the selection, or click Cancel to abort the selection.</p>	Auto Config	This setting automatically determines the optimal screen resolution.	XGA(1024x768) WXGA(1280x800) 720p (1280x720) 1080p (1920x1080)	You can specify your desired display output resolution.
Auto Config	This setting automatically determines the optimal screen resolution.				
XGA(1024x768) WXGA(1280x800) 720p (1280x720) 1080p (1920x1080)	You can specify your desired display output resolution.				



Settings:

Click the **Settings** button for more device settings for the NovoPRO. , access the Android system menu.

Firmware Upgrade: Click to upgrade the NovoPRO to the latest firmware version.

General Settings: Click to access the Android system menu.

Settings Protection: Click to set password protection for the NovoPRO. The **Configure Settings Protection** dialog window will pop up.



Configure Settings Protection:

To disable the password, click **Disable Protection**.

To set A password, click **Enable Protection**, then enter a password followed by its confirmation on the line below.

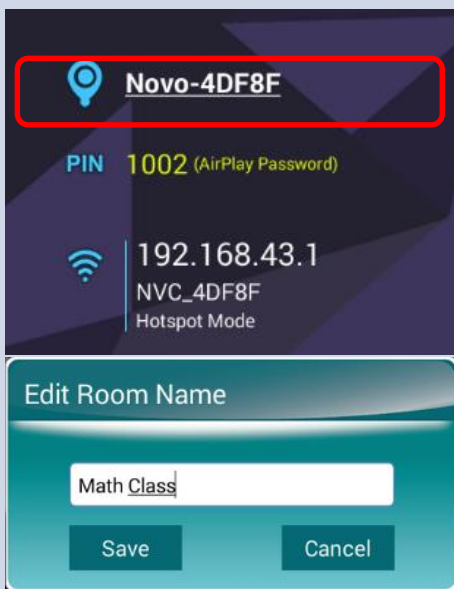

Reset:

To restart the NovoPRO:

Press and hold on the **Reset** tab for two (2) seconds. The NovoPRO will restart.

Presentation group name:

Click on the presentation group name shown in the lower right corner of the NovoPRO home screen. This will bring up the *Edit Room Name* window. Enter the new presentation group name using the on-screen soft keyboard. Click **Save** to confirm the name change, or click **Cancel** to abort the name change.

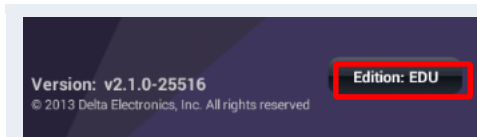

Set edition:

Click on the edition name shown on the top left corner of the NovoPRO home screen. This will bring up the edition selection window. Select either **Corporate Edition** or **Education Edition**, then click **Confirm** to make the edition change official, or click **Cancel** to abort the edition change.

The main difference between these two editions are as follows:



Corporate Edition

1. All *participants* can project screen contents directly onto the NovoPRO screen.
2. Moderator on/off function.
3. Tool bar:
 - a) PC/MAC – Supports *NovoScreenote*.
 - b) iOS/Android Tablets – Supports *Screenshot and Share*.

Education Edition

1. The *moderator* can preview the screen of any *participant* without permission.
2. Tool bar:
 - a) PC/MAC – Supports all functions.
 - b) Chromebook/iOS & Android Tablets – Supports all functions.

5.2 Configure NovoPRO system remotely

You can remotely configure your NovoPRO device through *Novo Desktop Streamer*. Click the  button after launching *Novo Desktop Steamer*, and select “Device Manager”.

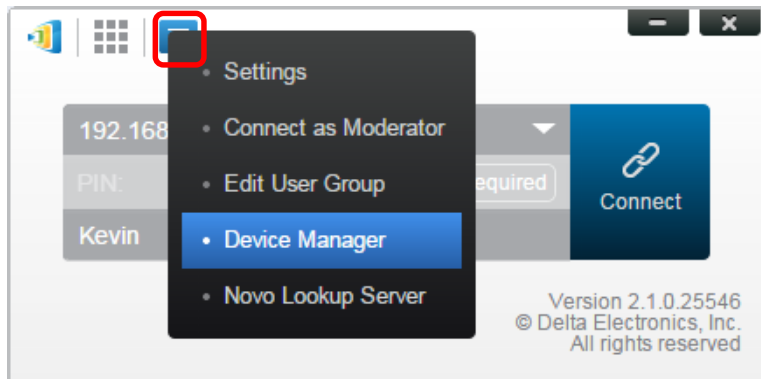

Please follow the steps below to access the functions described above.

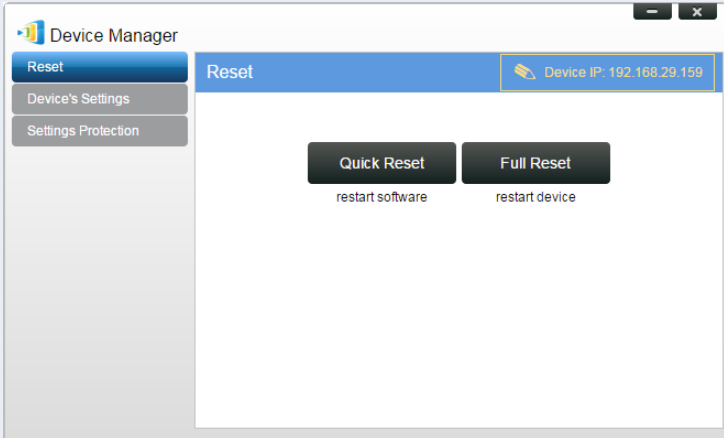
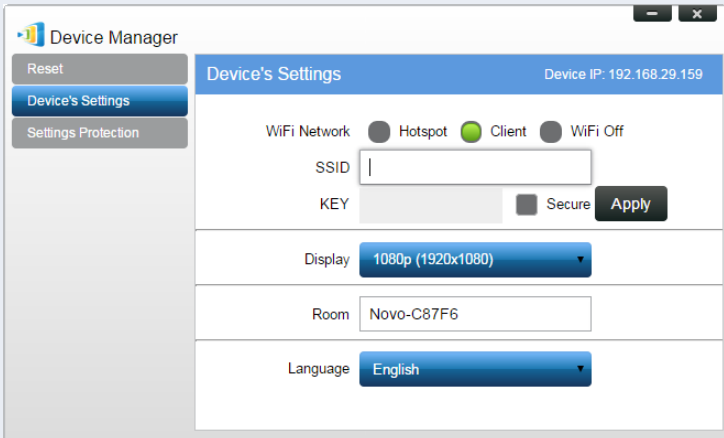
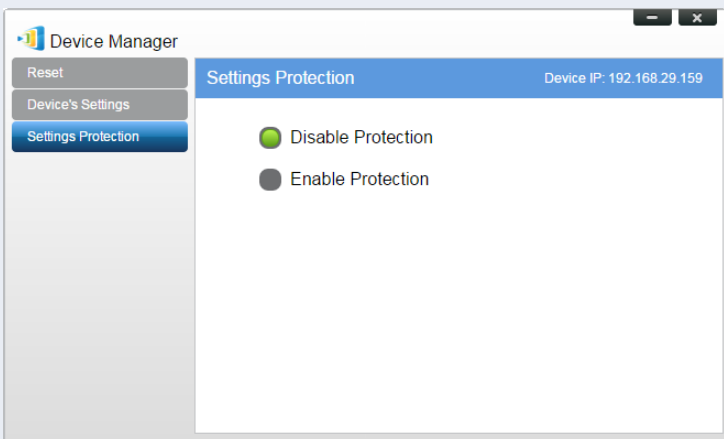
Function	Description
	<p>Do quick or full reset to NovoPRO device.</p>
	<p>Remotely configure your NovoPRO parameters from your desktop including:</p> <ul style="list-style-type: none"> • WiFi network parameters; • Display resolution; • Room Name; • Display language.
	<p>Enable or disable setting protection.</p>

5.3 Custom configuration file

5.3.1 Create and install custom configuration file

This function allows you to create and install a custom configuration file to set your Wi-Fi mode and logo file via a microSD card.

5.3.2 Download and open NovoPROConfig.xml template file

1. Go the NovoPRO Web site and download the zip file “SD Configuration”. Extract the “NovoPROConfig.xml” file from the zip archive.
2. Using either WordPad or another XML editing program, open the file “NovoPROConfig.xml”.
3. If you are using WordPad, follow these steps. Otherwise follow the procedures of your preferred XML editor.
4. Launch WordPad and open the template file. Use the view “All Documents” option when Open File window appears.

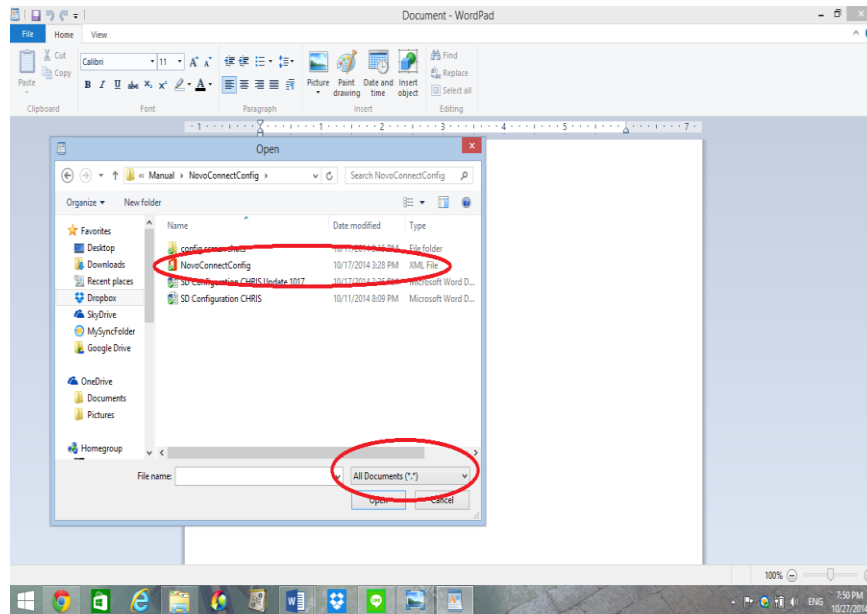

5.3.3 Fill in the values for personal configuration

1. When opened, the text will look like this:

```
<?xml version="1.0" encoding="utf-8"?>
<configuration>
  <wifi-ssid> example_wifi </wifi-ssid>
  <wifi-password>password_abcd</wifi-password>
  <logo-file-name>home_screen_logo.png</logo-file-name>
</configuration>
```

2. Replace the example SSID with your network’s SSID. The example SSID in the template is “example_wifi”.
3. Replace the example password with your Wi-Fi password. The Wi-Fi password in the in the template is “password_abcd”.
4. Save your changes to the template.

5.3.4 Add a home-screen logo (optional)

1. Choose an image for your logo. The image should be in the .png file format and no larger than 300 pixels height x 600 pixels width.

2. Replace the example image file name in the template with your custom image file name. The example image file name in the template is “home_screen_logo.png”.
3. Save your changes.

5.3.5 Copy and install files

1. Copy NovoPROConfig.xml file and your logo image file (optional) to a microSD card.
2. Insert the microSD card to the NovoPRO device.
3. Press the “reset” button to reboot the NovoPRO device.
4. After the reboot, both the Wi-Fi and the home-screen logo will be automatically set to the user’s custom configuration.

5.4 Wi-Fi reconnection

This feature allows tablet users to reconnect to NovoPRO after it has either powered down or lost its Wi-Fi connection. When the device is powered on again and reestablishes a Wi-Fi connection, a box will pop up asking if the user would like to reconnect to their last session.

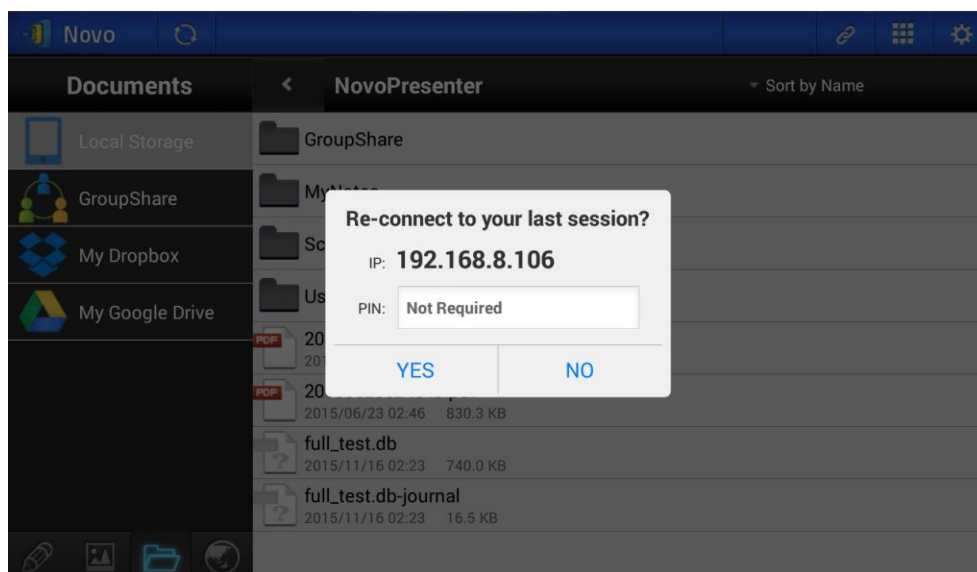

6. Specifications

Hardware Specifications	
Power Supply	5.35VDC, 2A
Power Consumption	< 10W
Output Resolutions	1024x768 (XGA), 1280x720 (HD), 1280x800 (WXGA), 1920x1080 (Full HD), Auto Config
CPU (SoC)	ARM Cortex A9 Quad-Core 1.6GHz
Memory	DDR 1024MB
Storage	Internal: 8GB (eMMC Flash) External: microSD Card Slot
Wi-Fi	802.11 a/b/g/n/ac (2.4GHz & 5GHz)
Input/Output	USB Input USB Type A x 1 Video Output HDMI x 1 Card Reader microSD Card Slot x 1 Ethernet 10/100 RJ45 type x 1 Power Input Micro USB (5.35V 2A)
LED Indicator	Green (System Power On) , Red (System Stand By) , Blue(Network Activity)
Button/Switch	Reset
Dimensions	120x 75 x 26 mm (L x W x H)
Weight	128 g
PC/Notebook Application Requirements	
CPU	Intel Pentium, 2GHz (Intel Core i3 and above are preferred)
Operating System	Windows XP, Windows 7, Windows 8 /10 (32 bits and 64 bits), Mac 10.6 and above
RAM	4 GB
Android Mobile Device Application Requirements	
Operating System	Android 3.2 and above (Android 4.0 and above are recommended)
Resolution	1024x768, 1280x800, or higher are recommended
iOS Mobile Device Application Requirements	
Operating System	iOS 5.1 and above
Device Type	iPad, iPad 2, iPad 3, iPad 4, iPad mini, and iPad Air

7. Troubleshooting

Q: NovoPRO does not power up or operate.

A: Check if the proper DC power supply with the appropriate operating voltage and sufficient operating current (5VDC, 2A) is connected to the Micro-USB port of the NovoPRO.

Q: My PC cannot link to NovoPRO wirelessly.

A: For your PC to link to NovoPRO, your PC must either have a built-in a Wi-Fi module or an external Wi-Fi adapter, and Wi-Fi must be enabled. If the NovoPRO is set to Hotspot Mode (factory default mode), choose NovoPRO's SSID from the available SSID list. If NovoPRO is set to Client Mode and is connected to a specific Wi-Fi AP, choose that AP's SSID from the available SSID list.

Q: The play/pause buttons do not work.

A: These buttons are functional only for the current *presenters*.

Q: I cannot connect to the Internet on NovoPRO.

A: This is normal if the NovoPRO is set to Hotspot Mode, since NovoPRO by itself does not support WAN (wireless wide area network) access. To access the Internet for tasks such as Web browsing on NovoPRO, please set the Wi-Fi to Client Mode and connect to a Wi-Fi AP that that is connected to the Internet.

Q: My PC or mobile device has failed to connect to NovoPRO.

A: First, make sure that Wi-Fi is enabled on your device. If NovoPRO is set to Hotspot Mode (factory default mode), choose the NovoPRO's SSID from the available SSID list. If NovoPRO is set to Client Mode and is connected to a Wi-Fi router, choose that router's SSID from the available SSID list.

Q: I cannot choose to present in full screen or in one of the split screens.

A: Only the *host* has the authority to decide whether your presentation is to be seen in full screen or one of the split screens. You may be invited to be the *host*: 1) if the Reset button is clicked on the NovoPRO , 2) if the *host* explicitly hands over *host* control to you, or 3) if all other *presenters* have disconnected from NovoPRO.

Q: I am the *host*, but I cannot preview other *participants'* screens.

A: To preview a *participant's* screen before sending a presentation invitation, that *participant* must have screen preview enabled on his device.

Q: My device's on-screen display looks stretched or compressed on NovoPRO's screen output.

A: There may be an aspect ratio mismatch between the NovoPRO's chosen output resolution and your device's screen aspect ratio (e.g. your device's screen has the 4:3 aspect ratio, and you have set NovoPRO's output resolution to a 16:9 or 16:10 option). Try to set the display resolution on the NovoPRO so that it has an aspect ratio that either matches that of your device or is as close to your device's screen aspect ratio as possible. You have the option of letting NovoPRO automatically determine the best output resolution by selecting Auto Config in the display settings.

Q: During the presentation, my PC/Mac computer's cursor is flickering.

A: You can try a different screen resolution for your PC/Mac computer. You can also try different settings for Projection Mode, Visual Quality, and Screen Refresh Rate (which need to be set before you connect your PC/Mac computer to your NovoPRO) until the problem disappears or is minimized.

8. Safety Information

Refer to the manual and take note of the safety instructions before operating your device.

- Ensure that the power source's output voltage matches your device's operating voltage.
- To prevent the risk of electric shock, do not operate this device near water or in environments of high moisture.
- Do not disassemble or try to repair this device by yourself. Contact your local Delta service center for assistance.
- Keep the device's plastic packages out of the reach of children.

9. Copyright Information

Copyright 2013 Delta Electronics, Inc. All Rights Reserved.

Android and Google are registered trademarks of Google Inc.

ARM is a registered trademark of ARM Inc.

App Store, iPad, iTunes, Mac, and Mac OS are service marks, trademarks, or registered trademarks of Apple Inc.

IOS is a trademark or registered trademark of Cisco in the U.S. and other countries and is used under license.

miniSD, microSD, miniSDHC, microSDHC, microSDXC, smartSD, smartSDHC, SDIO and miniSDIO are all trademarks or registered trademarks of SD-3C, LLC in the United States, other countries or both.

Microsoft and Windows are either trademarks or registered trademarks of Microsoft Corporation in the United States and/or other countries.

Pentium and Core i3 are registered trademarks of Intel Corporation.

VGA and XGA are registered trademarks of International Business Machines Corporation.

Product names, logos, brands, and other trademarks featured or referred to in this materials are the property of their respective trademark holders.

10. Index

1. access point
2. Android
3. NovoPRO
4. cable
5. click
6. Client Mode
7. configure
8. connect
9. device
10. disconnect
11. Dropbox
12. firmware upgrade
13. HDMI
14. host
15. Hotspot Mode
16. icon
17. install
18. internet
19. iOS
20. iPad
21. IWB
22. join
23. keyboard
24. login
25. Mac
26. mobile
27. mouse
28. NovoPRO
29. Novo Desktop Streamer
30. NovoPresenter
31. PC
32. PIN
33. participant
34. power
35. presentation
36. presenter
37. preview
38. projector
39. QR code
40. reset
41. Remote Viewer
42. resolution
43. role
44. screen
45. setting
46. software
47. SSID
48. tablet
49. touch
50. USB
51. Wi-Fi
52. Windows



205 Westwood Ave, Long Branch, NJ 07740
Phone: 866-94 BOARDS (26273) / (732)-222-1511
Fax: (732)-222-7088 | E-mail: sales@touchboards.com