

6. CONNECT CABLES AS REQUIRED TO IPAD AND REINSTALL IPAD MOUNTING PLATE TO BOX.

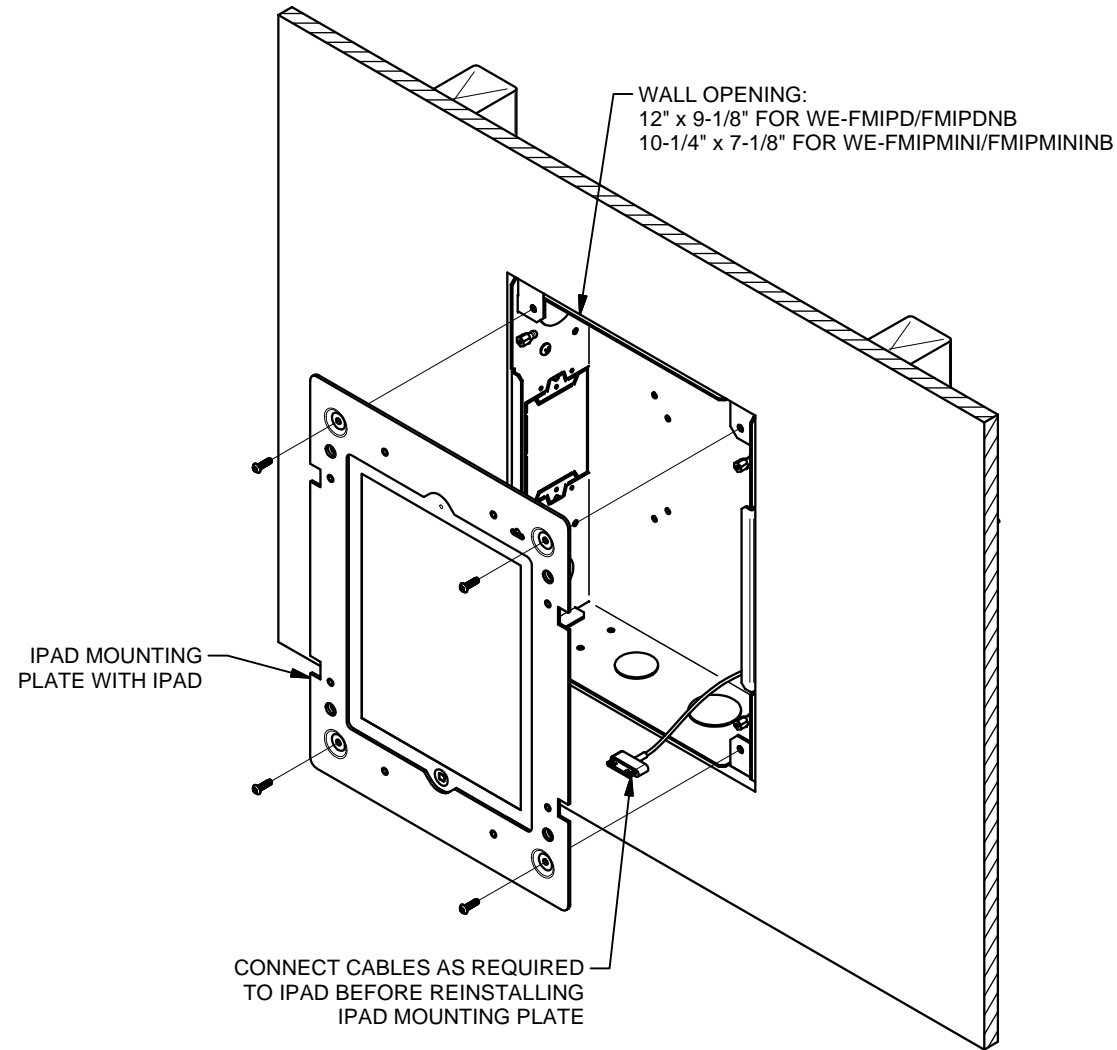

7. REINSTALL FRONT PANEL TO IPAD MOUNTING PLATE.

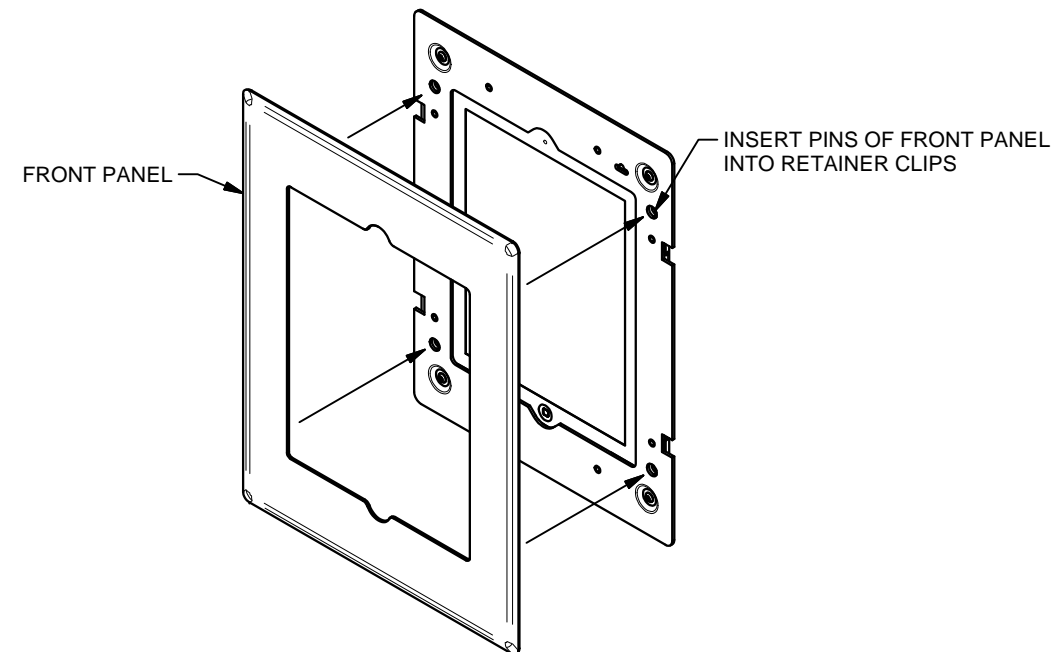

1. REMOVE FRONT PANEL FROM IPAD MOUNTING PLATE. FRONT PANEL WILL "SNAP" OFF FROM MOUNTING PLATE RETAINER CLIPS.

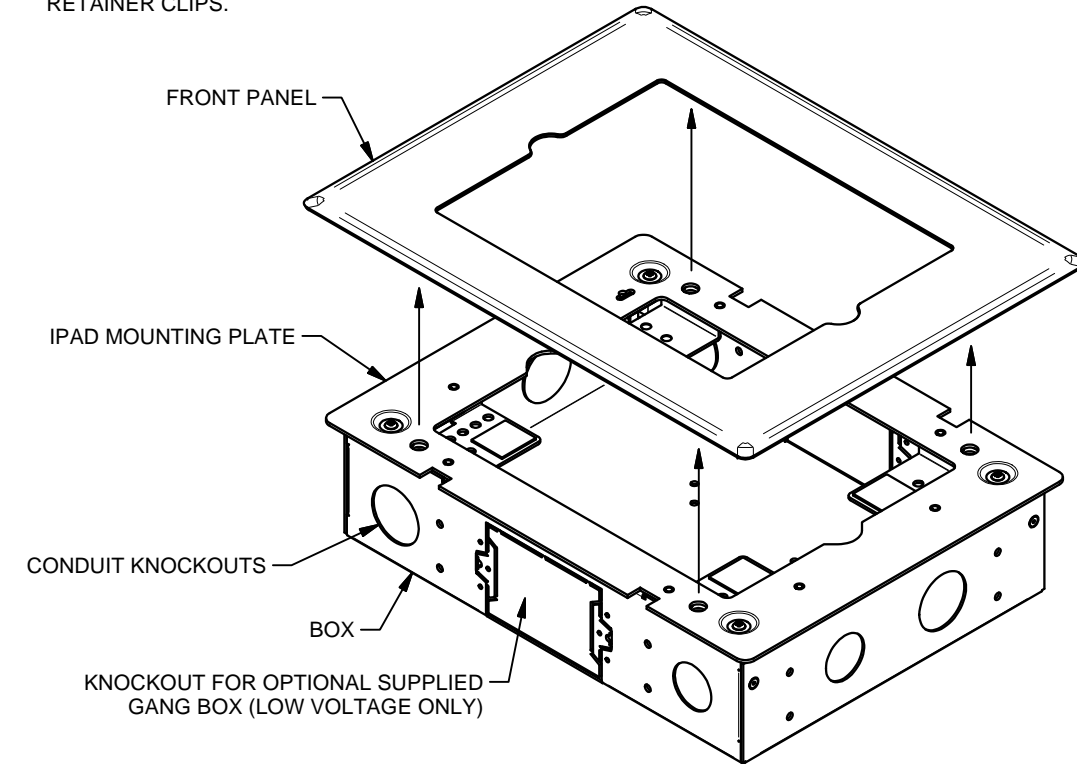

2. REMOVE IPAD MOUNTING PLATE WITH SUPPLIED HEX KEY.

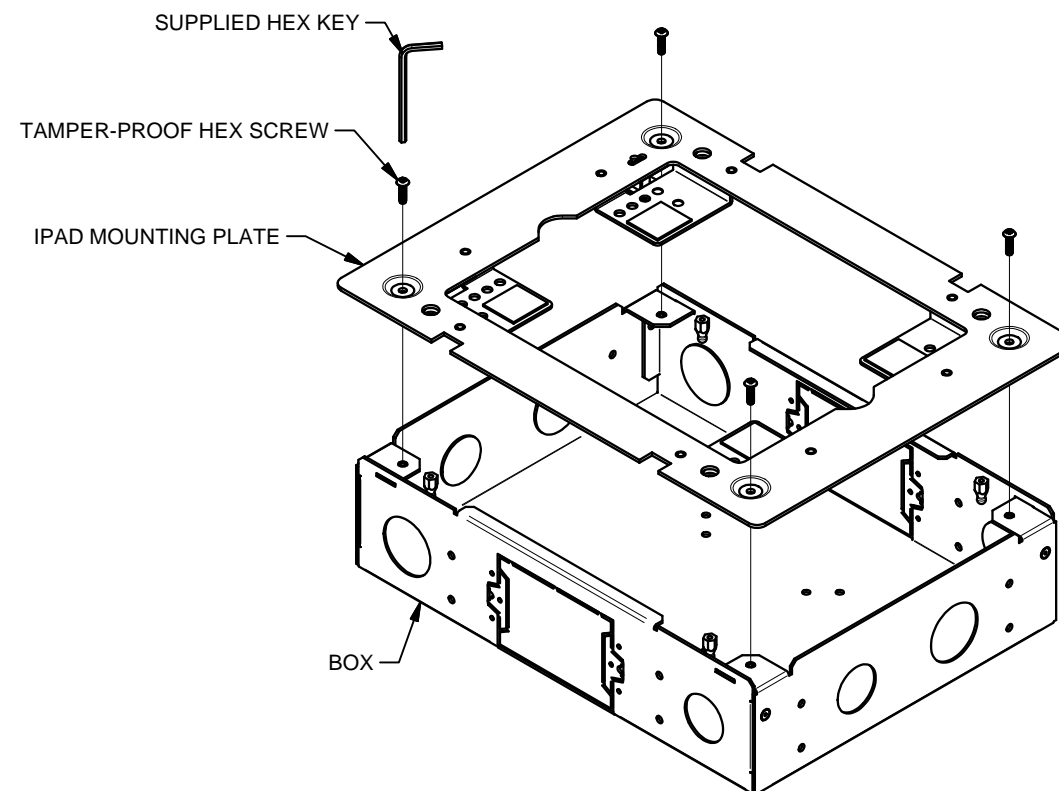

**NEW WORK**

3a. INSTALL SUPPLIED BOX MOUNTING BRACKETS AS REQUIRED WITH SUPPLIED #8-32 x 1/4" LONG PAN HEAD SCREWS. SEE BELOW FOR VARIOUS WAYS TO MOUNT THE BOX TO 16" STUD CENTERS.

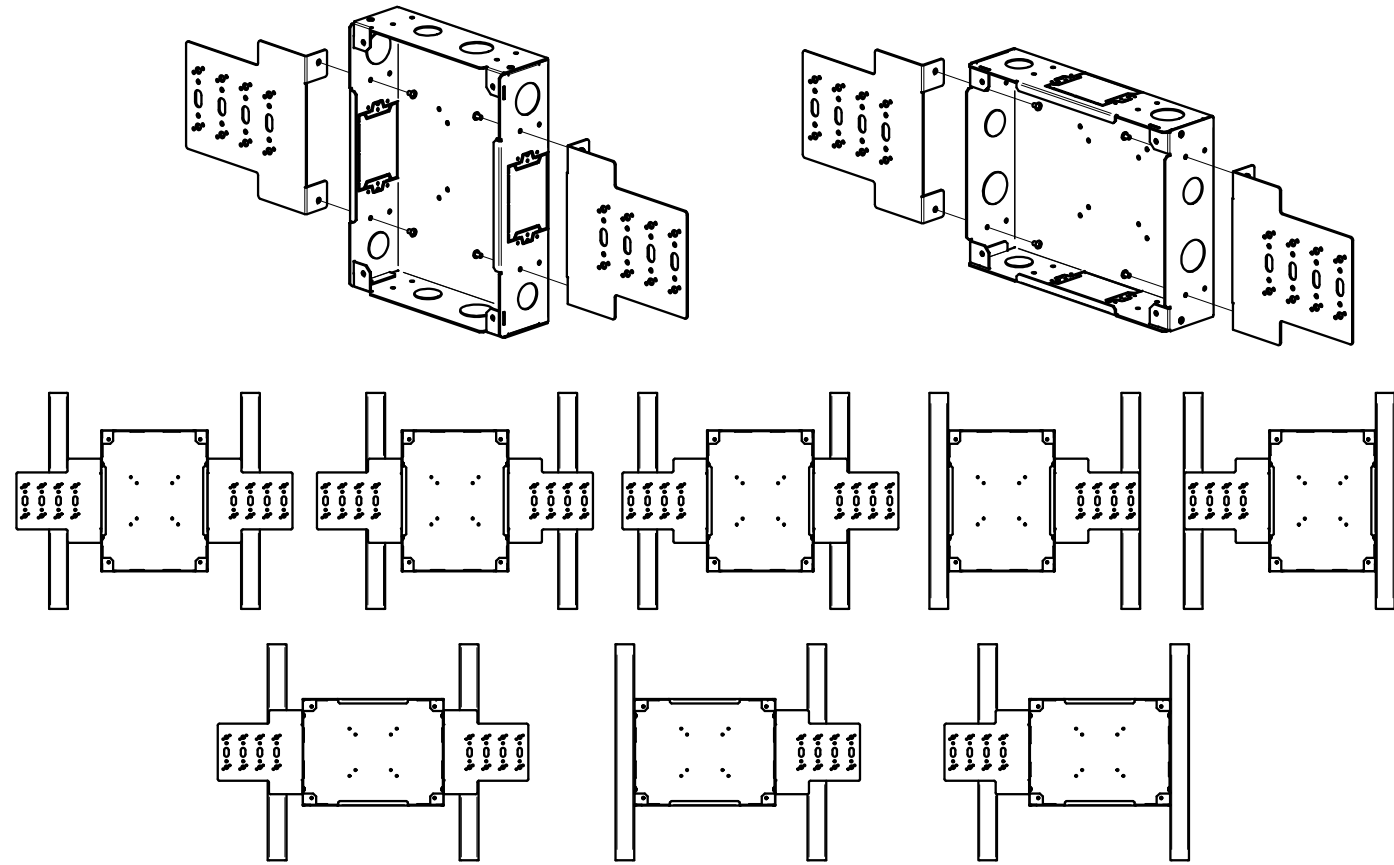

SECURE BOX TO STUDS AS REQUIRED. STUD MOUNTING HARDWARE (#6 SCREW, 1/2" x 1" STAPLE, NAIL, ETC) SUPPLIED BY CUSTOMER.

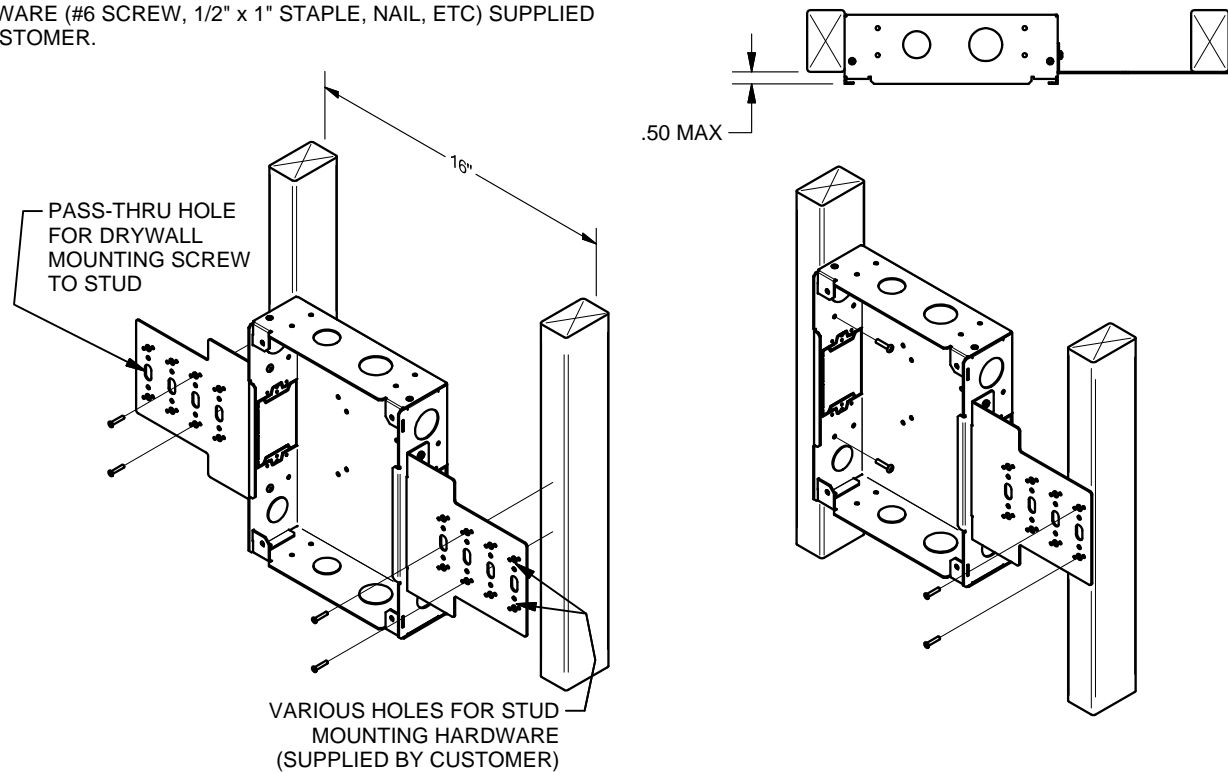

**OLD WORK**

3b. INSTALL SUPPLIED IN-STOP BRACKETS WITH SUPPLIED KEP NUTS AND MOUNT INSIDE WALL OPENING. INSTALL OLD WORK CLIPS APPROXIMATELY WHERE SHOWN. MINIMIZE CUTTING TO DRYWALL FOR CLIP INSERTION TO INSURE CLIPS HAVE MATERIAL TO SECURE BOX IN PLACE.

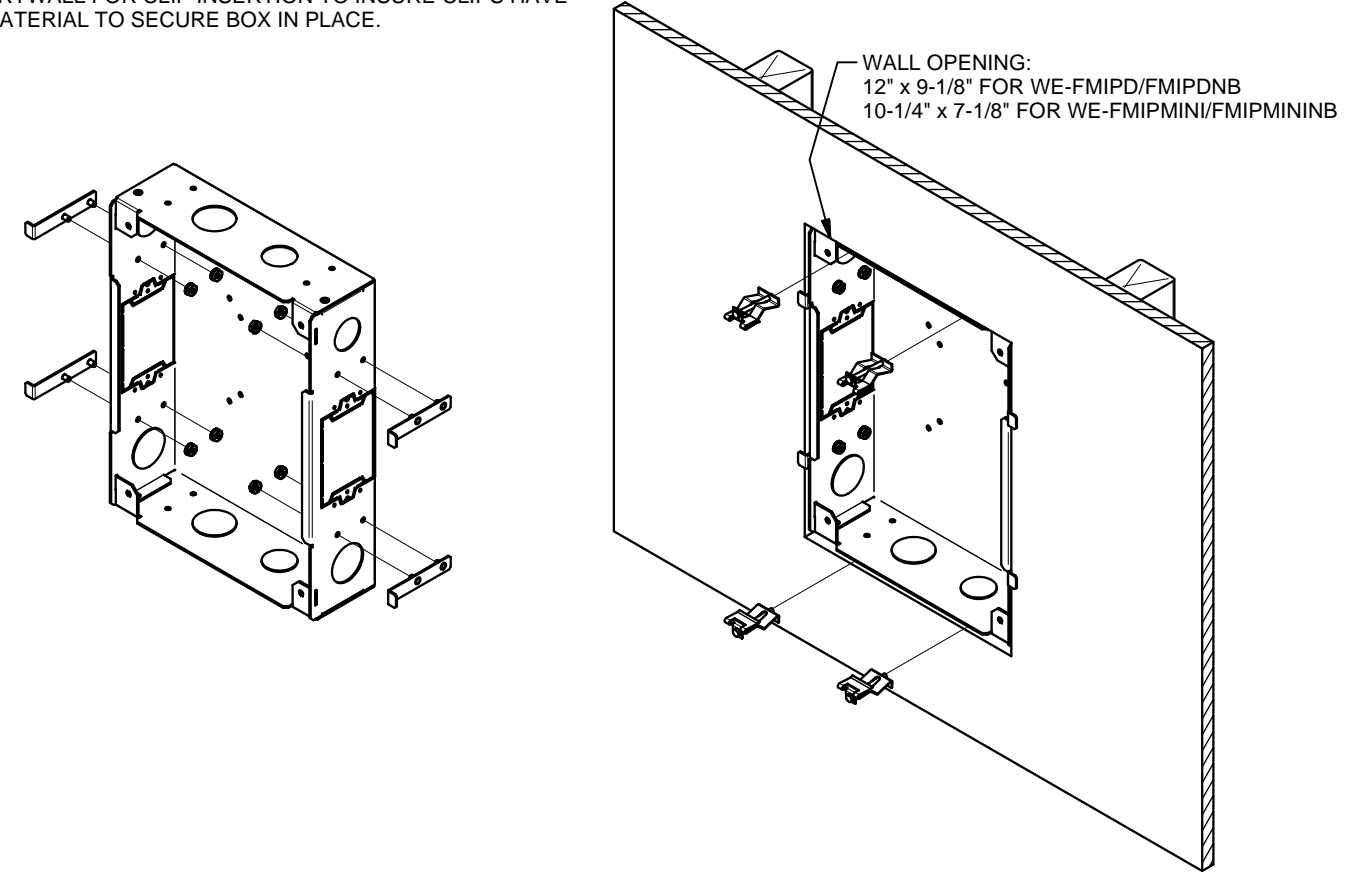

4. REMOVE IPAD MOUNTING BRACKETS FROM IPAD MOUNTING PLATE.

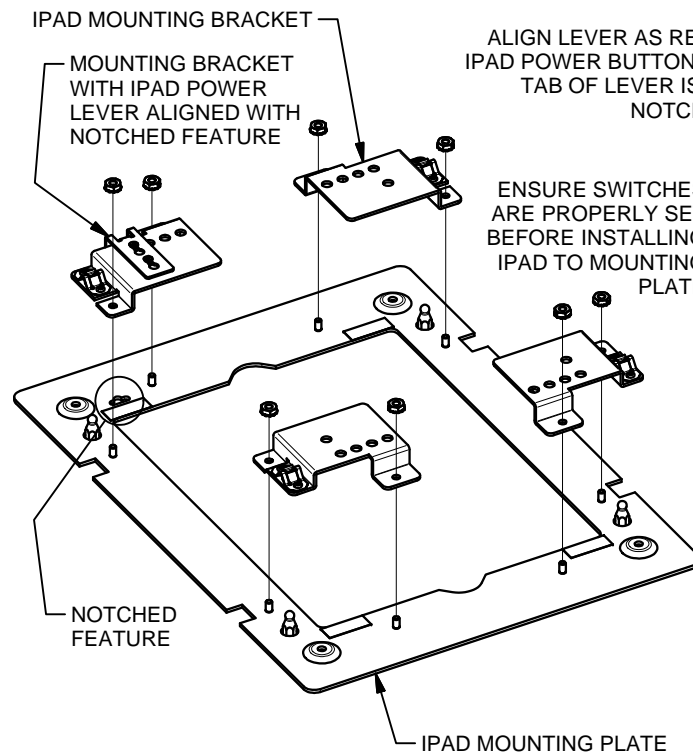

5. REINSTALL IPAD MOUNTING BRACKETS TO IPAD MOUNTING PLATE WITH IPAD (SUPPLIED BY CUSTOMER) AS SHOWN.

