

Weller®



Translation of the
original instructions

WTHA 1



www.weller-tools.com

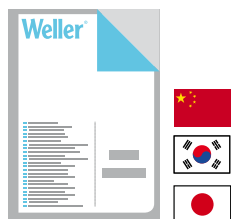

MANUAL



VIDEO



FAQ



1

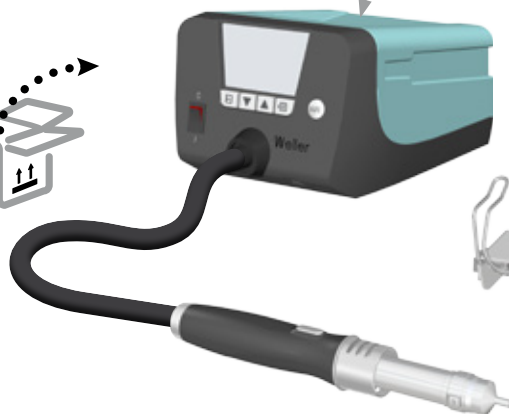
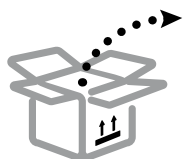

2

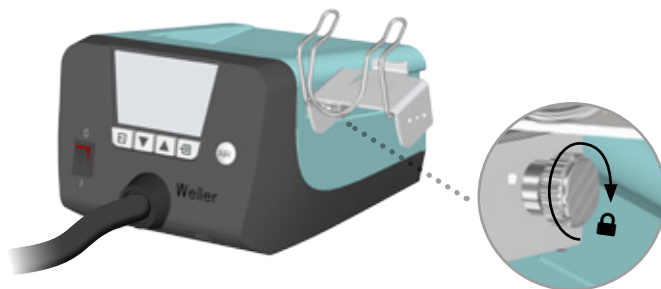
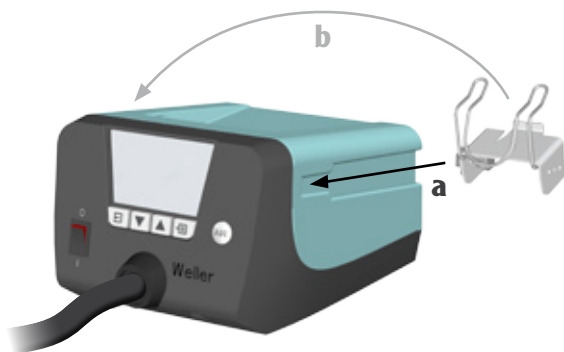

3



4

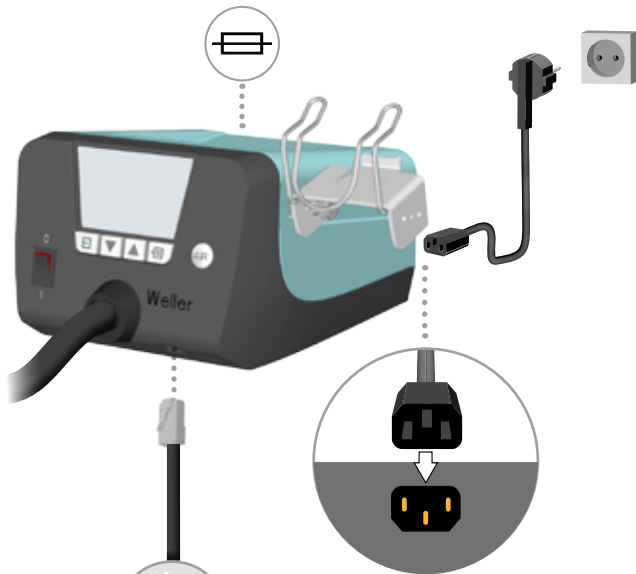

5

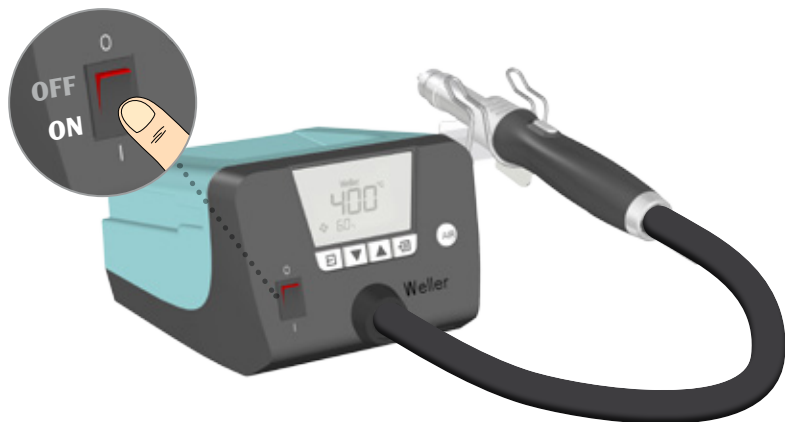

6

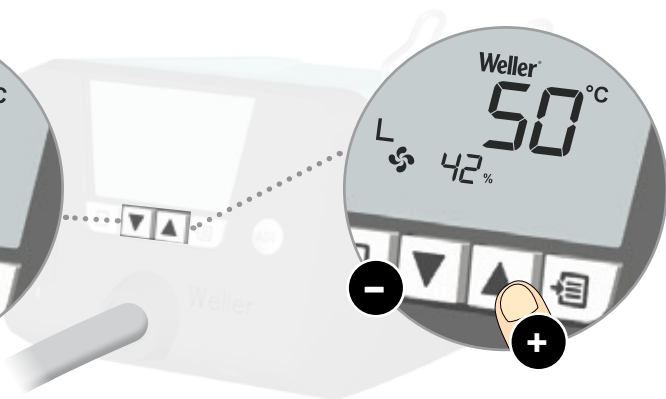
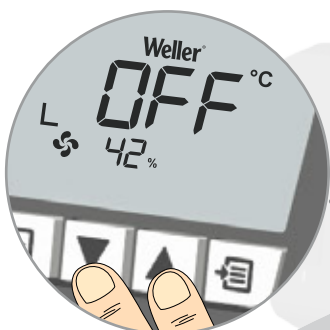
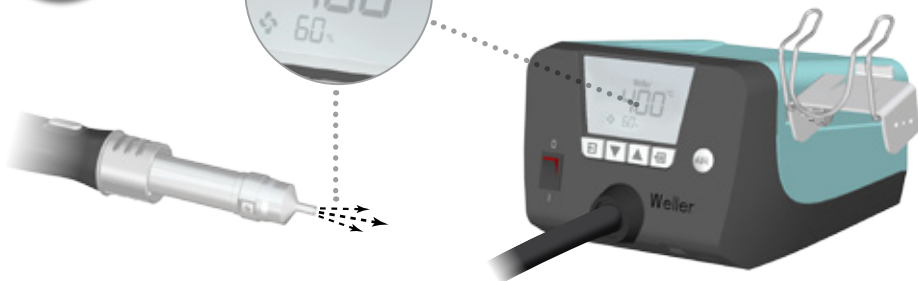

7

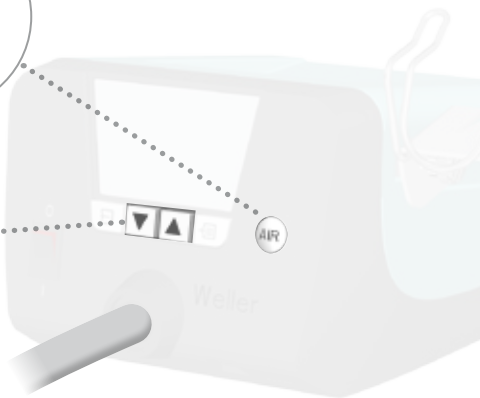
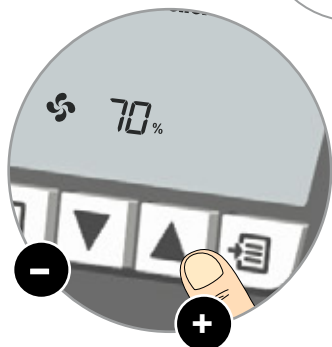
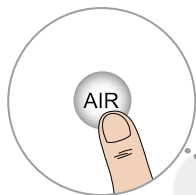

START/STOP



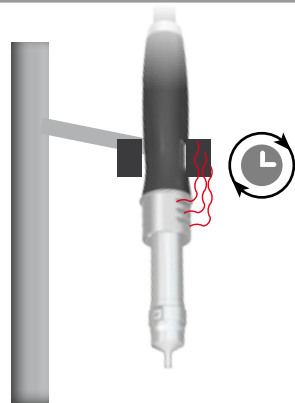
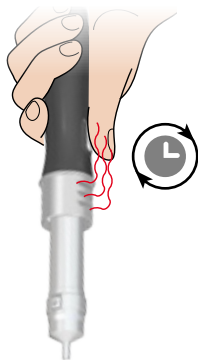
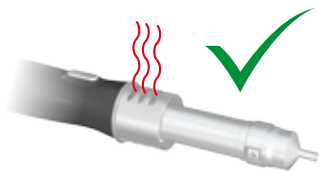

8

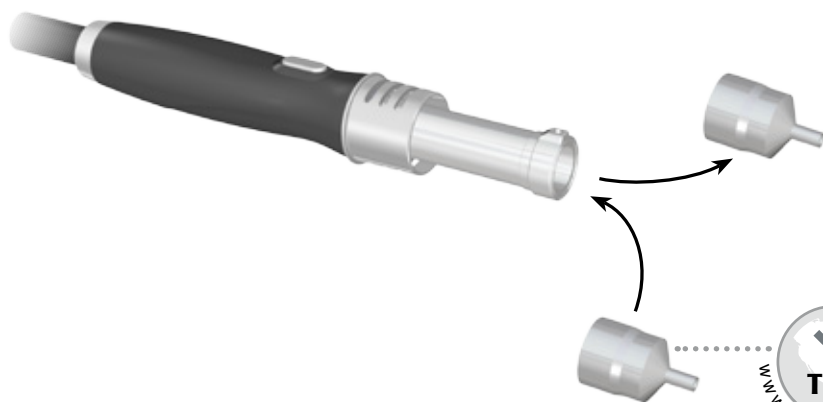
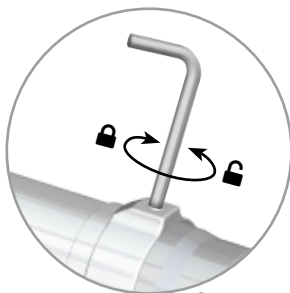

6

STANDBY



100 - 300 °C
200 - 600 °F

STANDBY TIME



1 - 99 min

TIME



1 - 999 min

WINDOW



1 - 99°C
1 - 180°F

MENU

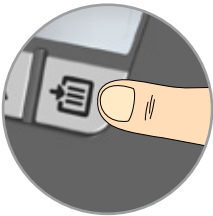

EXIT

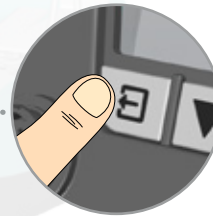

3
sec

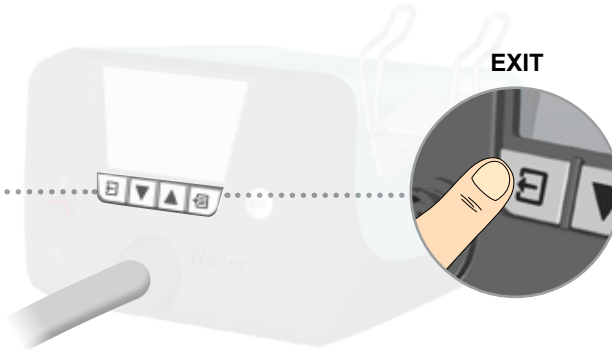

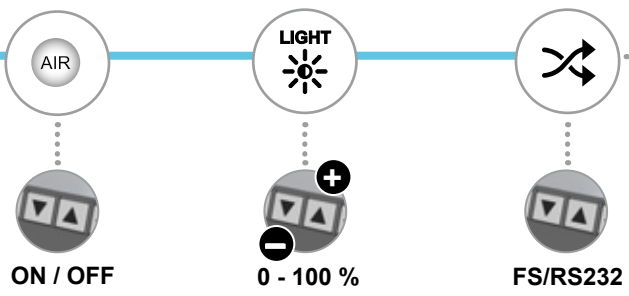
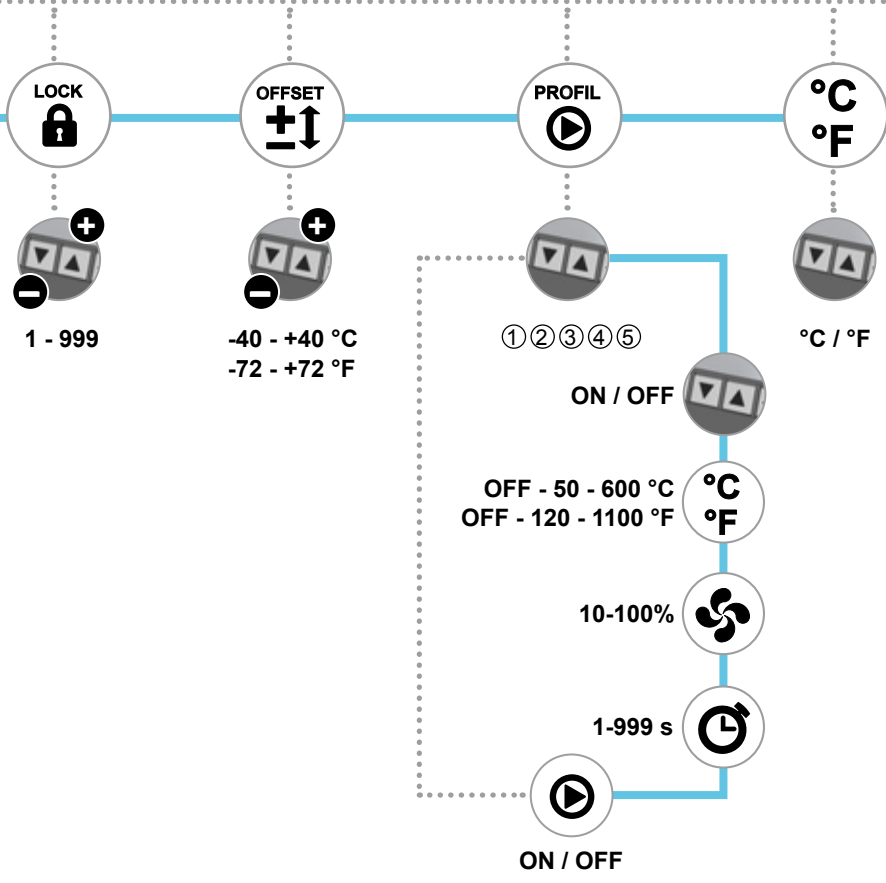



100 - 300 °C
200 - 600 °F

DE	Standby Temperatur	GR	Θερμοκρασία ετοιμότητας	LV	„Standby” temperatūra
EN	Standby Temperature	TR	Bekleme Sicakligi	LT	Budėjimo režimo temperatūra
ES	Temperatura standby	CZ	Standby teplota	BG	Standby температура
FR	Température Stand-by	PL	Temp. uśpienia	RO	Temperatura de standby
IT	Temperatura standby	HU	Készenléti hőfok	HR	Temperatura režima pripravnosti
PT	Temperatura Standby	SK	Nastavenie pohotovostnej teploty	RU	Темпер. ожидания
NL	Standbytemperatuur	SL	Temperatura v stanju pripravljenosti	CN	待机温度
SV	Vilotemperatur	EE	Ooterežiimi temperatuur	KO	스탠바이 온도
DK	Standby temp.			JP	待機温度
FI	Valmiuslämpötila				



1 - 99 min

DE	Standby Zeit	GR	Χρόνος ετοιμότητας	BG	Standby време
EN	Standby Time	TR	Bekleme Zamani	RO	Timpul de standby
ES	Tiempo standby	CZ	Pohot. čas	HR	Vrijeme režima pripravnosti
FR	Temps. Stand-by	PL	Czas do uśpienia	RU	Время ожидания
IT	Ritardo standby	HU	Készenléti idő	CN	待机时间
PT	Tempo de Standby	SK	Doba pohotovosti	KO	스탠바이 시간
NL	Stand-bytijd	SL	Čas stanja pripravljenosti	JP	待機時間
SV	Vilotemp. Tid	EE	Ooterežiimi aeg		
DK	Standby tid	LV	„Standby” laiks		
FI	Valmiusaika	LT	Budėjimo režimo laikas		



1-999 min

DE	OFF Zeit	GR	Χρόνος OFF	BG	OFF време
EN	OFF time	TR	OFF süresi	RO	Timpul OFF
ES	Tiempo OFF	CZ	Čas OFF	HR	Vrijeme OFF
FR	Durée OFF	PL	Czas funkcji OFF	RU	Время OFF
IT	Tempo di OFF	HU	Ki idő	CN	OFF时间 (自动关闭时间)
PT	Tempo de OFF	SK	Doba OFF	KO	자동 OFF 시간 (자동 작동 중지 시간)
NL	OFF-tijd	SL	Čas izklopa	JP	OFF 時間 (自動作動停止時間)
SV	Frånslagstid	EE	OFF aeg		
DK	OFF tid	LV	OFF laiks		
FI	OFF-aika	LT	IŠJ. laikas		



1 - 99°C
1 - 180°F

DE	Prozessfenster	FI	Prosessi-ikkuna	LT	Proceso langas
EN	Process window	GR	Παράθυρο διεργασίας	BG	Метод прозорец
ES	Rango de proceso	TR	Proses penceresi	RO	Fereastra procesului
FR	Fenêtre de processus	CZ	Okno proces	HR	Prozor s vrijednostima parametara
IT	Finestra di processo	PL	Okno procesu	RU	Окно процесса
PT	Intervalo de processamento	HU	Folyamatáblak	CN	过程窗口
NL	Procesvenster	SK	Procesné okná	KO	프로세스창
SV	Processfönster	SL	Okno za prikaz poteka	JP	プロセスウィンドウ
DK	Procesvindue	EE	Protsessiaken		
		LV	procesa intervāls		



1-999

DE	Verriegelungsfunktion	GR	Λειτουργία κλειδώματος	LT	Užrakinimo funkcija
EN	Lock function	TR	Kilitleme fonksiyonu	BG	Заклучване функция
ES	Función de bloqueo	CZ	Funkce blokování	RO	Funcția de blocare
FR	Fonction de verrouillage	PL	Funkcja blokady	HR	Lock funkciju
IT	Funzione di blocco	HU	Reteszelési funkció	RU	Заблокировать функцию
PT	Função de bloqueio	SK	Funkcia blokovania	CN	锁止功能
NL	Vergrendelingsfunctie	SL	Funkcija zapore procesnih parametrov	KO	잠금 기능
SV	Låsfunktion	EE	Lukustusfunktsioon	JP	ロック機能
DK	Låsefunktion	LV	Bloķēšanas funkcija		
FI	Lukitustoiminto				



-40 - 40 °C
-72 - 72 °F

DE	Offset	FI	Lämpötilakorjaus	LV	nobīde
EN	Offset	GR	Offset	LT	Nuokrypis
ES	Offset	TR	Offset	BG	Offset
FR	Offset	CZ	Teplot. kompenzace	RO	Offset
IT	Offset	PL	Offset	HR	Pomak
PT	Offset	HU	Offszet	RU	Корректировка
NL	Offset	SK	Tolerancia regulácie	CN	偏移量
SV	Offset	SL	offset	KO	오프셋
DK	Offset	EE	Ofset	JP	オフセット



1 2 3 4 5

DE	Profil	FI	Profiili	LV	Profils
EN	Profile	GR	Προφίλ	LT	Profilis
ES	Perfil	TR	Profil	BG	Профил
FR	Profil	CZ	Profil	RO	Profil
IT	Profilo	PL	Profil	HR	Profil
PT	Perfil	HU	Profil	RU	Профиль
NL	Profiel	SK	Profil	CN	型材
SV	Profil	SL	Profil	KO	프로파일
DK	Profil	EE	Profiil	JP	プロファイル



C/°F

DE	Temperaturversion	SV	Temperaturversion	EE	Temperatuuri versioon
EN	temperature units	DK	Temperaturversion	LV	Temperatūras veids
ES	Unidad de medición de la temperatura	FI	Lämpötilaversio	LT	Temperatūros versija
FR	Versión de température	GR	Έκδοση θερμοκρασίας	BG	Температурна версия
IT	Visualizzazione temperatura	TR	Sıcaklık versiyonu	RO	Versiunea temperaturii
PT	Versão da escala de temperatura	CZ	Jednotka teploty	HR	Prikaz temperature
NL	Temperatuurversie	PL	Wersja temperatury	RU	Температурная шкала
		HU	Hőmérséklet-verzió	CN	温度类型
		SK	Verzia jednotky teploty	KO	온도 단위
		SL	Enote temperature	JP	温度単位



ON / OFF

DE	Heißluft-Taste	FI	Kuumailmapainike	LV	Karstā gaisa taustiņš
EN	Hot air button	GR	Πλήκτρο καυτού αέρα	LT	Karšto oro mygtukas
ES	Botón de aire caliente	TR	Sıcak hava tuşu	BG	Бутон за горещ въздух
FR	Touche air chaud	CZ	Tlačítko horkého vzduchu	RO	Tastă aer cald
IT	Tasto aria calda	PL	Przycisk gorącego powietrza	HR	Tipka za vrući zrak
PT	Botão de ar quente	HU	Forrólevégő-gomb	RU	Клавиша подачи горячего воздуха
NL	Heteluchttoets	SK	Tlačidlo horúceho vzduchu	CN	热风按钮
SV	Hetluftsknapp	SL	Tipka za vroč zrak	KO	고온 공기 버튼
DK	Varmluft-knapp	EE	Kuumahunnup	JP	ホットエアボタン



0 - 100 %

DE	LCD-Grundhelligkeit	GR	Βασική φωτεινότητα LCD	LV	šķidro kristālu displeja gaišums
EN	LCD background brightness	TR	LCD parlaklığı	LT	LCD ryškumas
ES	Brillo LCD	CZ	LCD základní jas	BG	LCD-основна яркост
FR	Luminosité de base LCD	PL	Jaskrawość podstawienia wyświetlacza LCD	RO	Luminozitatea de bază LCD
IT	Luminosità sfondo LCD	HU	LCD alap fényerő	HR	LCD osnovna svjetlina
PT	Luminosidade de fundo do LCD	SK	Základný jas LCD	RU	LCD Яркость дисплея
NL	LCD-basishelderheid	SL	Svetlost LCD zaslona	CN	液晶显示屏基本亮度
SV	LCD-basljusstyrka	EE	LCD-taustahedus	KO	LCD 기본 밝기
DK	LCD-lysstyrke			JP	LCD 背景輝度
FI	LCD-peruskirkkaus				



FS/RS232

DE	Fußschalter / Schnittstelle RS232	HU	Lábkapcsolót / RS232-interfész
EN	Footswitch / RS232 port	SK	Nožný spínač / Rozhranie RS232
ES	Pedal / Puerto RS232	SL	Nožno stikalo / Vmesnik RS232
FR	Commutateur au pied / Interface RS232	EE	Jalgülüli / RS232-liides
IT	Pedale / Interfaccia RS232	LV	Pedālis / RS232 pieslēgvieta
PT	Pedal / Interface RS232	LT	Kojinis jungiklis / RS232 sąsaja
NL	Voetschakelaar / RS232-interface	BG	Педал за управление / RS232-интерфейс
SV	Fotströmbrytaren / RS232-gränssnitt	RO	Comutatorul de picior / Interfață RS232
DK	Fodkontakten / RS232-port	HR	Nožna sklopka / Sučelje RS232
FI	Jalalla kytkintä / RS232-liittymä	RU	Педалном выключател / Интерфейс RS232
GR	ποδοδιακόπτης είναι / Θύρα· διαπαφής· RS232	CN	脚踏开关 / RS232 接口
TR	Ayak şalterine / RS232 arabirimi	KO	풋 스위치 / RS232 인터페이스
CZ	Nožní spínač / Rozhraní RS232	JP	フットスイッチ / RS232 ポート
PL	Przełącznik nożny / Złącze RS232		

DE	Deutsch	Sicherheitshinweise Bestimmungsgemäße Verwendung Benutzergruppen Pflege und Wartung Garantie Technische Daten Symbole Original Konformitätserklärung	14
GB	English	Safety information Specified Conditions Of Use User groups Care and maintenance Warranty Technical Data Symbols Original declaration of conformity	17
ES	Español	Advertencias de seguridad Aplicación De Acuerdo A La Finalidad Grupo de usuarios Cuidado y mantenimiento Garantía Datos Técnicos Símbolos Declaración de conformidad original	20
FR	Français	Consignes de sécurité Utilisation Conforme Aux Prescriptions Groupes d'utilisateurs Entretien et maintenance Garantie Caractéristiques Techniques Symboles Déclaration de conformité d'origine	23
IT	Italiano	Avvertenze per la sicurezza Utilizzo Conforme Gruppi utenti Cura e manutenzione Garanzia Dati Tecnici Simboli Dichiarazione di Conformità originale	26
PT	Portugues	Indicações de segurança Utilização Autorizada Grupos de utilizadores Conservação e manutenção Garantia Características Técnicas Símbolos Original da declaração de conformidade	29
NL	Nederlands	Veiligheidsinstructies Voorgescreven Gebruik Van Het Systeem Gebruikersgroepen onderhouden Garantie Technische Gegevens Symbolen Origineel conformiteitsverklaring	32
SV	Svenska	Säkerhetsanvisningar Använd Maskinen Enligt Anvisningarna Användarkategorier skötsel och underhåll Garantier Tekniska Data Symboler Ursprunglig försäkran om överensstämmelse	35
DK	Dansk	Sikkerhedsanvisninger Tiltænkt Formål Brugergupper Pleje og vedligeholdelse Garanti Tekniske Data Symboler Original overensstemmelseserklæring	38
FI	Suomi	Turvallisuusohjeet Tarkoituksenmukainen Käyttö Käyttäjryhmät aseman hoito ja huolto Takuu Tekniset Arvot Symbolit Alkuperäinen vaatimustenmukaisuusvakuutus	41
GR	Ελληνικά	Υποδείξεις ασφαλείας Χρήση σύμφωνα με το σκοπό προορισμού Ομάδες χρηστών Φροντίδα και συντήρηση της συσκευής Εγγύηση Τεχνικά στοιχεία Σύμβολα Γνήσια Δήλωση πιστότητας	44
TR	Türkçe	Güvenlik uyarıları Kullanım Kullanıcı grupları temizliği ve bakımı Garantisi Teknik Veriler Semboller Orijinal uygunluk beyanı	47
CZ	Český	Bezpečnostní pokyny Použití v souladu s určením Uživatelské skupiny Údržba a servisní práce ohledně Záruka Technické údaje Symboly Originální prohlášení o shodě	50
PL	Polski	Bezpieczeństwo Użytkowanie Grupy użytkowników Pielęgnacja i konserwacja urządzeń Gwarancja Dane Techniczne Symbole Originalna deklaracja zgodności	53
HU	Magyar	Biztonsági utasítások Rendeltetésszerű használat Felhasználói csoportok Ápolás és karbantartás Garancia Műszaki Adatok Szimbólumok Eredeti megfeleléségi nyilatkozat	56
SK	Slovensky	Bezpečnostné pokyny Používanie v súlade s určeným účelom použitia Skupiny používateľov Ošetrovanie a údržba Záruka Technické údaje Symboly Originálne vyhlásenie o zhode	59
SL	Slovenščina	Varnostna navodila Uporaba v skladu s predpisi Skupine uporabnikov Nega in vzdrževanje Garancija Tehnični Podatki Simboli Originalna izjava o skladnosti	62
EE	Eesti	Ohutusjuhised Kasutusotstarbele vastav käitamine Kasutajarühmad Hooldamine ja teenindamine Garantii Tehnilised Andmed Sümbol Originaal-vastavusdeklaratsioon	65
LT	Latviski	Drošības norādes Atbilstoša lietošana Lietotāju grupas Apkope un kopšana Garantija Tehniskie dati Simboli Oriģinālā atbilstības deklarācija	68
LV	Lietuviškai	Saugos taisyklės Naudojimos pagal paskirtį Naudotojų grupės Įprastinė ir techninė priežiūra Garantija Techniniai duomenys Simboliai Atitikties deklaracijos originalas	71
BG	Български	Инструкции за безопасна работа Използване по предназначение Потребителски групи Обслужване и поддръжане Гаранция Технически данни Символи Оригинална Декларация за съответствие	74
RO	Român	Indicații de securitate Utilizarea conformă cu destinația Grupe de utilizatori Îngrijirea și întreținerea curentă Garanția pentru produs Date tehnice Simboluri Declarație de conformitate originală	77
HR	Hrvatski	Sigurnosna upozorenja Namjenska uporaba Skupine korisnika Njega i servisiranje Jamstvo Tehnički podaci Simboli Originalna izjava o skladnosti	80
RU	Русский	Указания по технике безопасности Использование по назначению Группы пользователей Уход и техническое обслуживание Гарантия Технические характеристики Символы Оригинальная декларация о соответствии	83
CN	中文	安全信息 规定的使用条件 用户群体 小心维护 保修 技术资料 符号/标志 符合标准说明原件	86
KO	한국어	안전정보 규정된 사용조건 사용자 그룹 관리 및 유지보수 보증 기술자료 표지 표준설명 부품에 포함되어야 한다.	88
JP	日本語	安全に関する情報 指定の使用条件 ユーザーグループ 保守及びメンテナンス 保証規定証 仕様諸元 シンボル オリジナルの適合宣言書	91



Read these instructions and the safety guidelines carefully before starting up the unit and starting work.

Failure to observe the safety regulations results in a risk to life and limb.

Keep these instructions in a place that is accessible to all users. Please adhere to the operating instructions of the connected devices.

Safety information

For safety reasons, children and youths under the age of 16, as well as persons who are not familiar with these operating instructions, may not use the device. Children shall not play with the appliance.

This device is not intended for use by persons (including children) with limited physical, sensory or mental aptitude, or by persons who lack knowledge or experience in handling the device.

Keep other persons well away from your workplace.

The work area is out of bounds for children and unauthorised persons. Never allow other persons to touch the soldering tool or cable.

▲ WARNING Electrical shock

Connecting the control unit incorrectly poses a risk of injury due to electric shock and can damage the device.

- Carefully read the attached safety information, the safety information accompanying these operating instructions as well as the operating instructions for your control unit before putting the control unit into operation and observe the safety precautions specified therein.
- Only connect WELLER tools.

If the device is faulty, active electrical conductors may be bare or the PE conductor may not be functional.

- Repairs must always be referred to a Weller-trained specialist.
- If the electrical tool's power supply cord is damaged, this must be replaced with a specially prefabricated power supply cord available through the customer service organisation.

Protect yourself against electric shocks. The handles on soldering tools with an antistatic design are conductive.

- Avoid touching earthed objects such as pipes, heaters, cookers and refrigerators.
- Do not use the soldering tool in a damp or wet environment.
- Never work on voltage-carrying parts.

▲ WARNING Risk of burns

Risk of burns from the soldering tool while the control unit is operating. Tools may still be hot long after they have been switched off.

- Always place the soldering tool in the safety rest while not in use. Make sure the safety holder is stable.
- Only replace nozzles when cold

Risk of burning through liquid solder. Protect yourself against solder splashes.

- Wear appropriate protective clothing to protect yourself against burns. Protect your eyes by wearing eye protectors.
- When working with adhesives, special attention must be paid to the warning information provided by the adhesive manufacturer.

▲ WARNING Fire hazard

Covering the soldering iron or the safety holder poses a fire hazard. Always keep objects well away from the soldering iron and safety holder.

- Always keep objects well away from the soldering iron and safety holder.
- Keep all combustible objects, liquids or gases well away from the hot soldering tool.
- Do not direct hot air soldering tools at people or inflammable objects.

Store your soldering tool in a safe place. When not in use, units and tools should be stored in a dry, high or locked area out of the reach of children. Make sure that unused soldering tools are free of voltage and de-pressurised.

The mains cable must only be plugged into the mains socket or adapter approved for this purpose. Check to see if the mains voltage matches the ratings on the nameplate. Make sure the machine is switched off before plugging in.

Do not use the cable for purposes other than those for which it is intended. Never carry the unit by the cable. Do not use the cable to pull the plug out of the socket. Protect the cable against heat, oil and sharp edges.

Be alert. Pay attention to what you are doing. Be smart when using the unit. Do not use the soldering tool if you are having difficulty concentrating.

Avoid abnormal posture. Arrange your work station in an ergonomically correct way. Avoid bad posture when using the unit, as this can lead to postural problems.

The soldering tool must be operated only in perfect technical working order. Safety devices must not be deactivated.

Faults and defects must be repaired immediately.

Before using the unit / tool, safety devices must be carefully checked to make sure that they are functioning properly and in the manner intended. Check that moving parts are functioning properly and are not sticking, and whether parts are damaged. All parts must be correctly fitted and must satisfy all the requirements necessary to guarantee troublefree operation of the unit.

Use the correct tool. Use only accessories or auxiliary devices which are included in the list of accessories or approved for use by the manufacturer. Use WELLER accessories or auxiliary devices on original WELLER equipment only. The use of other tools and other accessories can cause injury.

Secure the tool. Use clamping fixtures to hold the workpiece.

Use a solder fume extraction unit. If appliances for connecting solder fume extraction units are available, ensure that they are connected and used properly.

Specified Conditions Of Use

Supply unit for WELLER soldering tools. Use the hot air station only for the purpose of soldering, as specified in the Operating Instructions.

This device may only be used at room temperature and indoors. Protect against moisture and direct sunlight.

User groups

Due to differing degrees of risk and potential hazards, several work steps may only be performed by trained experts.

Work step	User groups
Setting the hot air parameters	Specialist personnel with technical training
Replacing electrical replacement parts	Electricians
Default maintenance intervals	Safety expert
Operation	Non-specialists
Operation Replacing electrical replacement parts	Technical trainees under the guidance and supervision of a trained expert

Care and maintenance



Before doing any work on the machine, pull the plug out of the socket. Leave the unit to cool down.

Check all connected cables and hoses for damage and proper functioning before putting into operation.

If power tools are damaged, they must be immediately removed from use. Do not use blocked nozzles.

Repairs must always be referred to a Weller-trained specialist.



Use original replacement parts only.

Pay attention to fuse rating on nameplate.

Warranty

Claims by the buyer for physical defects are time-barred after a period of one year from delivery to the buyer. This does not apply to claims by the buyer for indemnification in accordance with §§ 478, 479 BGB (German Federal Law Gazette).

We shall only be liable for claims arising from a warranty furnished by us if the quality or durability warranty has been furnished by use in writing and using the term „Warranty“.

The warranty shall be void if damage is due to improper use and if the device has been tampered with by unauthorised persons.

For more information please visit www.weller-tools.com.

WTHA 1

