

DWD 102

Digi-Wave™ Dual-Bay Docking Station

USER MANUAL

Compatible with Digi-Wave™ Models:
DLT 100 2.0, DLR 60 2.0 and DLR 60



Touchboards

205 Westwood Ave, Long Branch, NJ 07740
Phone: 866-94 BOARDS (26273) / (732)-222-1511
Fax: (732)-222-7088 | E-mail: sales@touchboards.com

System Overview

Thank you for purchasing the DWD 102 Digi-Wave™ Dual-Bay Docking Station.

The Digi-Wave™ Dock, when used with second-generation Digi-Wave 2.0 products, can be used to receive audio through a Digi-Wave™ receiver (or transceiver) and send the audio into a sound system, or send audio from a sound system to a transceiver for broadcast. There are many applications for the dock; for more information please visit our website and download the ***Digi-Wave Dock Applications Guide***.

The Digi-Wave™ Dock supports audio input/output functions with the DLT 100 2.0, DLR 60 2.0 and DLR 60 models. It will only act as a charger for the DLT 100.

System Includes

- (1) DWD 102 Digi-Wave™ Dual-Bay Docking Station.
- (1) TFP 048 Power Supply
- (1) WLC 004 Line Cord (U.S.)
- (2) WCA 078 Stereo RCA Cables
- (4) RBP 005 Support Pads 1/8" (thick)
- (4) RBP 006 Support Pads 1/16" (thin)

Recycling Instructions

Help Williams Sound protect the environment! Please take the time to dispose of your equipment properly.



Product Recycling for Customers in the European Union:

Please do NOT dispose of your Williams Sound equipment in the household trash. Please take the equipment to an electronics recycling center; OR, return the product to the factory for proper disposal.



Battery Recycling for Customers in the European Union:

Please do NOT dispose of used batteries in the household trash. Please take the batteries to a retail or community collection point for recycling.

Connectors and Controls

Figure 1: Rear View

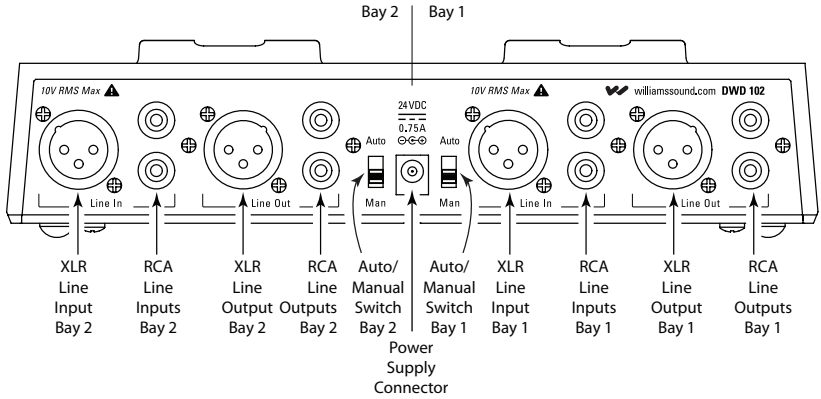
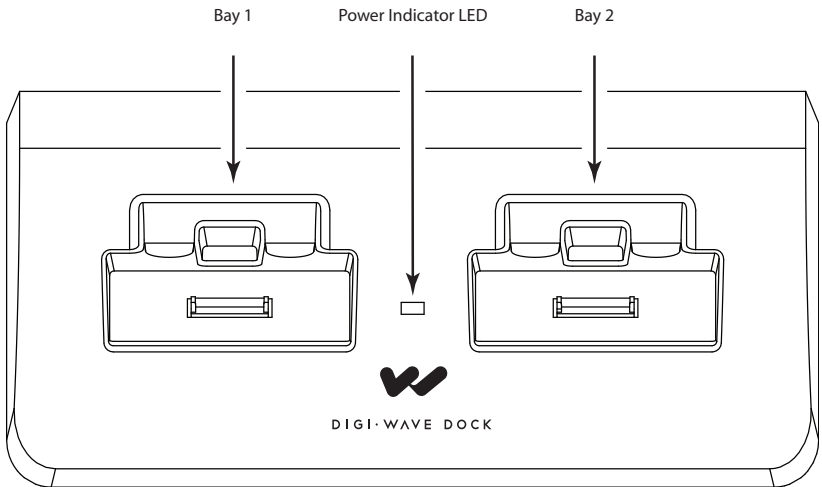

Figure 2: Top View



Setup Instructions:

1. Connect the external devices to the XLR or RCA jacks on the back of the Digi-Wave™ Dock (Figure 1). Both RCA and the single XLR input jacks are all mixed internally - but for proper mixing to occur at the output without any adjustments, the following combinations can be used: One single RCA jack by itself, both RCA jacks, the XLR jack by itself, or both RCA jacks and the XLR jack. If one RCA jack is to be mixed with the XLR jack, the gain of the RCA source will need to be adjusted at the source.
2. Select DLT mode. We recommend using “Chairman Master” mode for two reasons: (1) The Chairman Master has #1 Talk Priority so the Talk button on this unit can never be bumped off by another user, and (2) The Chairman Master will be powered by the dock, and all other units synchronize to the Chairman Master, making it a more reliable Master than one powered from the internal battery.
3. Insert any combination of DLT 100 2.0 transceiver(s) or DLR 60 2.0 receiver(s) into the bays (Figure 2). The unit(s) must be facing forward for proper mating to the 30-pin connector.
4. Using the appropriate line cord (US, EURO, UK or AUS) into the TFP 048, plug the TFP 048 power supply into the AC wall outlet. Plug the power connector into the rear of the DWD 102 unit (figure 1). The green LED power indicator should light up (Figure 2).
5. Select either Auto or Manual for each docked device, using the switch(es) on the back. See Figure 3 for an explanation of the difference between the two modes.

You may charge any combination of DLT 100 2.0, DLT 100, DLR 60 2.0, or DLR 60s. (In DLR 60 2.0 and DLR 60 units, NiMH batteries must be used and the battery switch must be in the NiMH position.) Digi-Wave™ Dock audio inputs/outputs are only available on the DLT 100 2.0, DLR 60 2.0, and DLR 60. DLT 100s can be docked but will charge only (no audio). See Digi-Wave™ Dock Functions chart (Figure 3).

Note: It is safe to leave the DLT and DLR units in the charger, even after the batteries are fully charged. The charger will switch to ‘maintain’ mode to maintain full battery potential.

Figure 3: Digi-Wave™ Dock Functions

	DLT 100 2.0	DLR 60 2.0 / DLR 60
Charges Unit with Dock Power ON	Yes (internal battery)	Yes - with NiMH AAA batteries in DLR only; if no batteries present dock will power DLR (if battery switch is in NiMH position).
Charging Status	Shown on DLT if unit is OFF	Shown on DLR (NiMH only)
Internal Mic	Muted when docked	n/a
Internal Speaker	Muted when docked	Muted when docked
Audio Inputs/Outputs	Input and Output enabled	Output enabled
Auto Mode		
TALK function	When unit is Chairman Master in 2-way mode, or Presenter in 1-way mode (CH 0), TALK button is locked ON. No effect in other modes	n/a
Power Up/Down	Powers DLT ON when power applied to dock; powers DLT OFF when power removed from dock	Powers DLR ON when power applied to dock; powers DLR OFF when power removed from dock (battery switch position "NiMH")
Manual Mode		
TALK function	TALK button must be pushed manually	n/a
Power-Up	Acts as a charger only	Acts as a charger only



205 Westwood Ave, Long Branch, NJ 07740
Phone: 866-94 BOARDS (26273) / (732)-222-1511
Fax: (732)-222-7088 | E-mail: sales@touchboards.com

DLT microphone mixing with dock sources

The dock's inputs - two mono RCA jacks (-10dBV) and one XLR jack (+4dBu) - are mixed together in the dock, then sent to the DLT 100 2.0. The DLT 100 2.0 then mixes the dock audio with its microphone before transmitting.

Depending upon what sources are being mixed, there may be a level mismatch between the dock and the DLT's microphone level. The DLT 100 2.0 includes line-level adjustment for proper mixing.

To adjust the DLT 100 2.0 line-level gain, hold the “^” button for 3 seconds. The default level is “L:5”, or 0dB of gain adjustment. See Figure 4 below for level settings and corresponding gain/attenuation.

Figure 4: DLT Setting/Digi-Wave™ Dock Functions

Level Setting on DLT	0	1	2	3	4	5	6	7
Line-level Gain/Attenuation (dB)	Mute	-12dB	-9dB	-6dB	-3dB	0dB	+3dB	+6dB

Note: The “microphone volume” adjustment can also be used, but may require other DLTs microphone levels to be adjusted too, which makes it a more cumbersome method, and therefore line-level adjustment is recommended.

Installing the Support Pads

Two sets of supporting pads have been supplied with the dock to support the back of the unit(s) when sitting in the dock; thick (1/8") and thin (1/16"). Use the table below to choose which pad thickness to use (Figure 5). See the diagram below showing where to affix the pads (Figure 6).

Figure 5: Support Pad Required

DLT 100	DLT 100 with skin	DLR 60	DLR 60 with skin
Thick pad (1/8")	Thin pad (1/16")	Thin pad (1/16")	No pad

Figure 6: Support Pad Installation

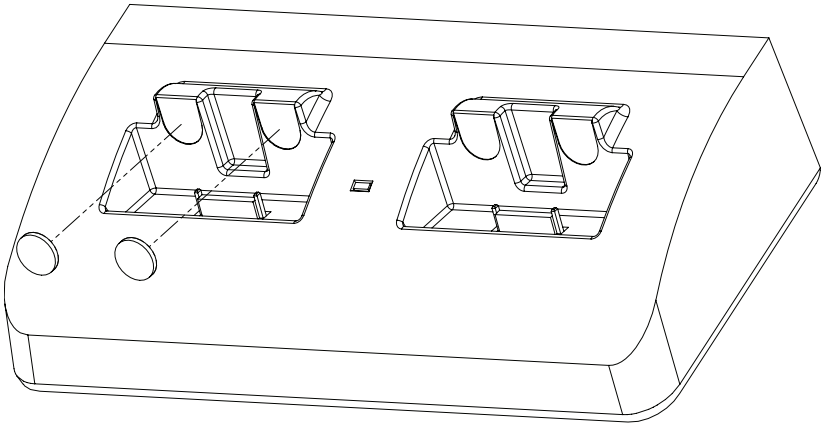

DWD 102 Specifications

Dimensions	8.88" x 4.34" x 2.16" (226 mm x 110 mm x 55 mm) LxWxH
Shipping Weight	1.4 lbs (0.64 kg)
Enclosure	Black, heavy duty plastic molded top, with steel base and non-skid rubber feet. White legends on back.
DC Power Input	2.5mm ID barrel connector, 24VDC input, 750mA, Center Positive.
Power Supply	Williams Sound TFP 048. Input: 100-240VAC 50/60Hz, 18W. Output: 24VDC, 750mA.
Charging Time	DLT 100 2.0: 5 hours nominal (internal LiPo Battery)* DLR 60 2.0: 15 hours nominal, based on Williams Sound NiMH battery BAT 022-2.
Unit Capacity	2 Units: DLT 100 2.0, DLR 60 2.0, or DLR 60. DLT 100 units will charge only (no audio).
Indicators	Green LED indicating power at the charger/dock. Charging status is shown on unit being charged.
Rear Inputs	One set of L/R RCAs, single-ended, -10dBV typical, per bay. One female XLR, balanced line-level, +4dBu typical, per bay.
Rear Outputs	One set of L/R RCAs, single-ended, -10dBV typical, per bay. One male XLR, balanced line-level, +4dBu typical, per bay.
Dock Connector	One 30-pin connector per bay. Supports power/charging, audio in, audio out, and control signals.
Controls	One 2-position switch per bay, for "manual" or "auto" mode.
Warranty	2 Years
Approvals	FCC, CE, RCM, Industry Canada, RoHS2, CB scheme, Energy Star V

*Charging specifications are based on internal rechargeable LiPo battery (not serviceable).

Specifications subject to change without notice.

New batteries have various charge conditions. Some DLT/DLR's may take less or more time to fully charge. Charging batteries generates heat. The receivers, transceivers, charger, and power supply may feel warm when charging. Do not charge units in a closed enclosure, such as a carry case or brief case.

Troubleshooting

No audio transmitted from docked DLT 100 2.0:

1. Make sure the DLT is seated firmly on the dock's 30-pin connector.
2. Make sure the dock and DLT are powered ON.
3. Check the source input into the dock - make sure it is connected, powered on and playing/producing audio.
4. Verify that the incoming audio level is sufficient.
5. Make sure the TALK button red ring light is ON on the DLT.
6. Make sure the DLT is set up as a Chairman Master (recommended). Other modes can be used but talk priority may cause the docked DLT to go off-air when another unit enables the TALK function.
7. Make sure the DLT and DLR(s) are on the same Group.
8. Verify the DLT is transmitting audio. Take it out of the dock, talk into the on-board microphone, listen with a DLR receiver and make sure it is receiving audio. When this is verified, put the DLT back in the dock.
9. Verify the DLT 30-pin attenuator setting is not 0, as this mutes the dock input.

No audio received by docked DLT 100 2.0 or DLR 60 2.0:

1. Make sure the DLT (or DLR) is seated firmly on the dock's 30-pin connector.
2. Make sure the dock and DLT or DLR are powered ON.
3. Make sure the sending and receiving transceiver/receiver are both on the same Group.
4. Make sure the TALK button red ring light is ON on the DLT that is serving as the transmitter.
5. Make sure the receiving DLT/DLR is receiving audio. Take it out of the dock, listen to the on-board speaker and make sure it is receiving audio. When this is verified, put it back in the dock.
6. Check the dock output for the bay by connecting the RCA or XLR outputs to a device that will show or produce audio, such as a boombox or small mixer with VU meters.
7. Make sure the device receiving audio from the dock is connected, powered on, and if applicable - on the correct bay/output for the dock (the two bays are not connected).
8. The audio output level is different for the RCA and XLR jacks. Make sure the correct output is being used for the connected equipment.

One or more source audio levels too quiet or too loud (not mixing evenly):

1. If the RCA inputs are being used with an XLR source, **both** RCA inputs must be used to mix evenly with the XLR source. If using a mono RCA source, it must be wyed-out (using a Y-cable or adapter) and sent into both RCA inputs. If just one RCA is used, when mixed with the XLR, it will not mix evenly and will be quieter than the XLR source.
2. If the DLT microphone level is not mixing evenly with the XLR and/or RCA sources, adjust the DLT line input level to match the microphone audio level (see section on “DLT microphone mixing with dock sources”).
3. If the transmitted audio is distorting, turn the DLT line level down (see section on “DLT microphone mixing with dock sources”), or turn the audio level down at the source.

DLT/DLR not charging or indicating charge:

1. Make sure the DLT or DLR are seated firmly on the dock's 30-pin connector(s).
2. Check that the line cord is firmly plugged into the power supply, the power supply is plugged into the AC outlet, and the power supply connector is plugged in on the back of the Digi-Wave™ Dock inserted firmly until it stops.
3. Verify the dock's green power LED is ON.

Note: DLTs do not indicate charge status when powered ON, but DLRs do.

4. On DLR, verify the NiMH batteries are installed correctly (not reversed) and battery switch is set to “NiMH” position.

2 Year Warranty

Williams Sound products are engineered, designed and manufactured under carefully controlled conditions to provide you with many years of reliable service. Williams Sound warrants the DWD 102 Digi-Wave™ Dual-Bay Docking Station against defects in materials and workmanship for TWO (2) years. During the first 2 years from the purchase date, we will promptly repair or replace the DWD 102.

Microphones, earphones, headphones, rechargeable batteries, cables, carry cases, and most other accessory products carry a 90-day warranty.

WILLIAMS SOUND HAS NO CONTROL OVER THE CONDITIONS UNDER WHICH THIS PRODUCT IS USED. WILLIAMS SOUND, THEREFORE, DISCLAIMS ALL WARRANTIES NOT SET FORTH ABOVE, BOTH EXPRESS AND IMPLIED, WITH RESPECT TO THE DWD 102, INCLUDING BUT NOT LIMITED TO, ANY IMPLIED WARRANTY OF MERCHANTABILITY OR FITNESS FOR A PARTICULAR PURPOSE. WILLIAMS SOUND SHALL NOT BE LIABLE TO ANY PERSON OR ENTITY FOR ANY MEDICAL EXPENSES OR ANY DIRECT, INCIDENTAL OR CONSEQUENTIAL DAMAGES CAUSED BY ANY USE, DEFECT, FAILURE OR MALFUNCTION OF THE PRODUCT, WHETHER A CLAIM FOR SUCH DAMAGES IS BASED UPON WARRANTY, CONTRACT, TORT OR OTHERWISE. THE SOLE REMEDY FOR ANY DEFECT, FAILURE OR MALFUNCTION OF THE PRODUCT IS REPLACEMENT OF THE PRODUCT. NO PERSON HAS ANY AUTHORITY TO BIND WILLIAMS SOUND TO ANY REPRESENTATION OR WARRANTY WITH RESPECT TO THE DWD 102. UNAUTHORIZED REPAIRS OR MODIFICATIONS WILL VOID THE WARRANTY.

The exclusions and limitations set out above are not intended to, and should not be construed so as to contravene mandatory provisions of applicable law. If any part or term of this Disclaimer of Warranty is held to be illegal, unenforceable or in conflict with applicable law by a court of competent jurisdiction, the validity of the remaining portions of this Disclaimer of Warranty shall not be affected, and all rights and obligations shall be construed and enforced as if this Limited Warranty did not contain the particular part or term held to be invalid.

Your warranty becomes effective the date you purchase your system. Your returned warranty card is our way of knowing when your warranty begins. Please take a moment to fill it out and mail the enclosed card. You may also register your product online: <http://www.williamssound.com/Warranty-registration>

If you experience difficulty with your system, call Toll-Free for Customer Assistance:

1-800-843-3544 (U.S.A.) or 1-952-943-2252 (Outside the U.S.A.)

If it is necessary to return the system for service, your Customer Service Representative will give you a Return Authorization Number (RA) and shipping instructions.

Touchboards

205 Westwood Ave, Long Branch, NJ 07740
Phone: 866-94 BOARDS (26273) / (732)-222-1511
Fax: (732)-222-7088 | E-mail: sales@touchboards.com

 **WILLIAMS SOUND®**

10300 Valley View Rd • Eden Prairie, MN 55344
800-328-6190 / 952-943-2252 • FAX: 952-943-2174
www.williamssound.com

©2014 Williams Sound • All Rights Reserved MAN 180C