

TalkPerfect DX

Handbook Contents:

- Safety
- Introduction
- Installation
- Block Diagram
- Controls and Connections
- Specification
- Warranty Information
- Declaration of Conformity

Standard Kit Contents:

- 1 x TalkPerfect DX
- 1 x Combi Speaker/Microphone
- 1 x POD Speaker
- 1 x Glass Mount Microphone
- 1 x Power supply.
- 1 x 6 way Control connector
- 2 x 4 way connectors
- 1 x Phono to Jack cable
- 1 x Bag of clips & ties
- 1 x TalkPerfect DX Handbook (this document)
- 1 x Installation handbook



Safety:



This symbol is used to alert the user to important operating or maintenance instructions.



The Lightning bolt triangle is used to alert the user to the risk of electric shock.

1. It is important to read these instructions, and to follow them.
2. Keep this instruction manual in an accessible place.
3. Clean only with a dry cloth. Cleaning fluids may effect the equipment.
4.  The amplifier generates some heat during normal operation and needs adequate ventilation. Do not install in a fully enclosed space.
5. Do not install near any heat sources such as radiators, heating vents, or other apparatus that produces heat.
6. Refer all servicing to qualified personnel. Servicing is required when the apparatus has been damaged in any way, such as a power supply cord or plug is damaged, liquid has been spilled or objects have fallen into the apparatus, the apparatus has been exposed to any rain or moisture, does not operate normally or has been dropped.
7.  **WARNING** - To reduce risk of fire or electric shock, do not expose this apparatus to rain or moisture. The apparatus shall not be exposed to dripping or splashing and no objects filled with liquids, such as vases, shall be placed on the apparatus.

WILLIAMS AV

AMPETRONIC

Listen to the difference

Introduction:

The Ampetronic TalkPerfect DX is a two-way voice enhancement system.

Intended for use at Security Reception Desks, Customer Returns Points, Banks, Post Offices, Rail, Train and Bus ticket counters, Bureau de Change, in-fact any area that has a Glazed Security Screen, the system is robust and built with a high standard of construction.

The TalkPerfect DX contains signal processing for system stability and clarity of speech and is shipped pre-set, directly for use with minimum set up adjustment.

There is a 'Loop Line Output' port for direct connection to a CLD1 induction loop driver where fitted.

For detailed guidance on installation, operation and maintenance of the TalkPerfect system, consult the installation handbook provided, or contact the supplier of the system.

Installation:

You will require the following tools:

- Small flat bladed screwdriver.
- Screws and appropriate tools for mounting on under a counter.

Before installing the equipment, check that you have all of the parts that are contained in the contents list.

This handbook only relates to the TalkPerfect DX system, and not other system components. See Installation handbook provided for detailed explanation of installation procedure with a range of microphone and speaker options.

Block Diagram:

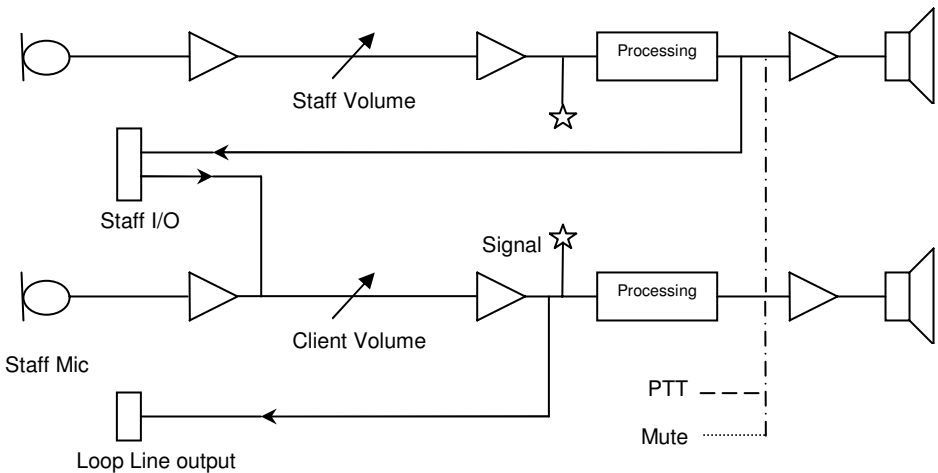

Controls and connections:

Front panel controls

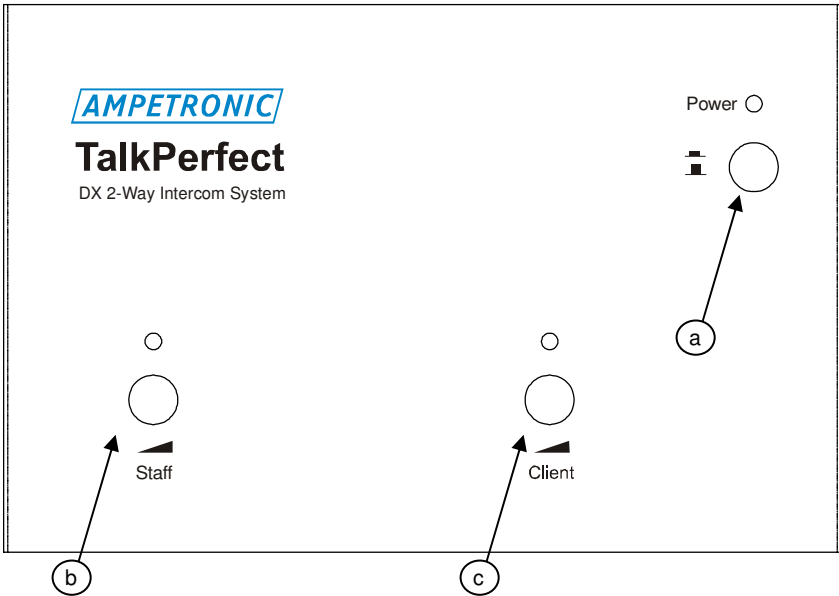

Lower panel connectors

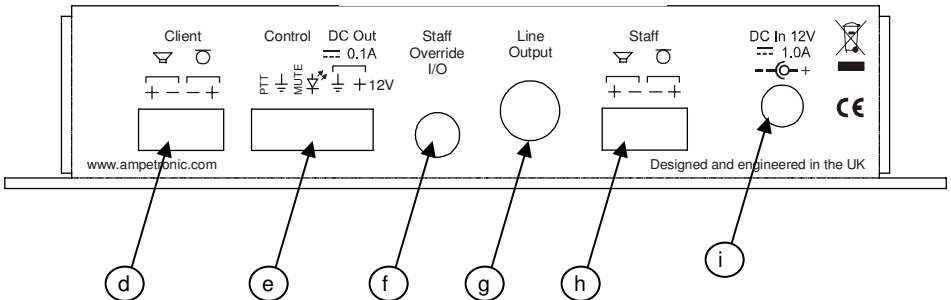

- a. ON/OFF switch.
- b. Staff volume control.
- c. Client volume control.
- d. Client Mic / Speaker connections.
- e. Control connections
- f. Staff Override I/O.
- g. Line Output
- h. Staff Mic / Speaker connections
- i. DC Power input

PTT (Push to Talk) – When activated, this function mutes the Client Mic, and increases the volume of the Staff to Client channel.

Mute – When activated, this function mutes both channels, effectively putting the system on standby. The LED output from this port is turned off to indicate this.



See specification for details of requirements for each port

Ensure no stray wires bridge connections

Specification:

- Mic Inputs: Unbalanced microphone input, Gain: >+60dB (control at max).
Sensitivity: -50dBu @ 1kHz with gain control at maximum level
Input noise level: -124dBu, Suitable source: <1k Ω
Input impedance: 8k Ω , DC bias voltage: 6V though 1k
- Speaker O/Ps: <0.5% THD @ 1kHz with +11dBu (1W into 8 Ω), 20Hz - 10kHz
Minimum load: 4 Ω , Maximum output level: +14dBu.
- Control port: Short PTT & Mute to ground to activate. Mute turns LED output off.
LED output indicates if the system is active – connect to ground.
+12V for external module supply. 100mA fused.
- Staff Override: Unbalanced Line - 3.5mm jack socket, Input = Tip, Output = Ring
Gain >+30dB, Sensitivity -10dBu Suitable Source: <1k Ω
Maximum output level +4dBu, typical -10dBu, Output Z: 220 Ω
- Line Output: Unbalanced Phono socket
- Environmental: IP30, -10 $^{\circ}$ C to +45 $^{\circ}$ C, 20 – 90% relative humidity
- Dimensions: 200 x 110 x 44 mm, 475g
- DC Power: 12Vdc, Quiescent: 170mA 2W, Maximum: 1.0A 12W
- Standards: Meets relevant CE, EMC and safety standards
Maximum cable length for all connections is 3m

Warranty information:

This product carries a five year parts and labour warranty from date of shipment from Ampetronic. To qualify for the five year warranty, the product must be registered at www.ampetronic.co (products/warranty), without which the warranty will be valid for two years only. Accessories have only 1 year warranty.

The 5-year warranty is dated from the time the equipment leaves Ampetronic and NOT when it is installed.

Declaration of Conformity:

Manufacturer: Ampetronic Ltd.
Address: Unit 2, Trentside Business Village, Farndon Road, Newark, NG24 4XB

Declares that the product: TalkPerfect DX

Conforms to the following Directive(s) and Norm(s):

Directive 2004 / 108 / EC

EMC: EN 55103 (1&2):2009

Directive 2006 / 95 / EC

Safety: EN 60065:2002+A12:2011

Directive 2011 / 65 / EU RoHS

Date: February 2014, J.R. Pieters, Managing Director, Ampetronic Ltd.

Ampetronic Ltd.

www.ampetronic.co

Email: sales@ampetronic.co

Williams AV

www.williamsav.com

USA: info@williamsav.com

INTL: info-intl@williamsav.com