

# 8 Short Cut™ Series Micro-Shear® Flush Cutters

# SHORT CUT™

## SERIES

Short-Cut™ Series shears feature an ergonomically-enhanced size and shape. Hand grip dimensions are optimized to the size and shape of the human hand. Their unique shape and Xuro-Rubber™ grips provide a secure “fit” in the operator's hand resulting in more precise control.

Short-Cut™ Series shears feature a glare eliminating black finish for operator comfort and enhanced contrast between the component lead and tool and our patented, lifetime warranted, *Light Touch™* return spring.

Static dissipative grips are optionally available.

### 410 Micro-Shear® Flush Cutter

The premium grade version of our world famous 170-II Micro-Shear® Flush Cutter. Its size and shape are optimized for work in high density areas. The patented Micro-Shear® blade by-pass reduces both cutting effort and mechanical shock (impact) transmitted to the component. High carbon steel blades are precision ground to ultra sharp cutting edges. Its unique, state of the art heat-treating process yields a Rockwell hardness of 55-57C. The result is a tough, precise, durable flush cutter capable of reliably and economically cutting soft wire up to 18AWG (1.02mm).

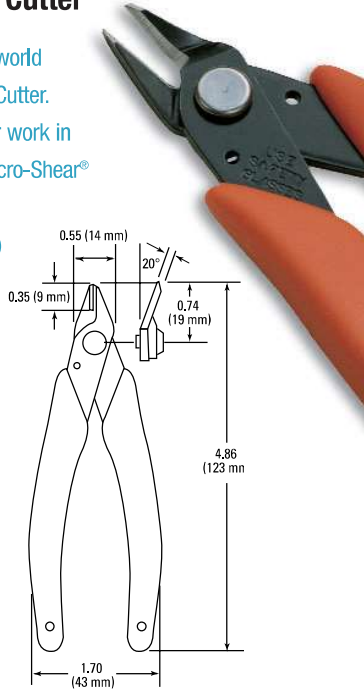

### 410F Micro-Shear® Flush Cutters

Our 410 with a factory-installed lead retainer. Design provides a low profile and non-slip mounting on the shear. Helps prevent flying leads and component shorting from stray leads. Cuts soft wire up to 18 AWG (1.02mm).



### 410T Micro-Shear® Flush Cutter

Our 410 shear with ultra sharp precision tips and an extra thin tip profile. Provides the ultimate in maneuverability and operator control; allows work in areas other tools cannot even enter. Ideal for SMD or high density areas. Due to the low mass of the cutter head, care should be exercised to avoid overstressing the tips. Maximum cutting capacity is 22 AWG (0.64mm) soft wire.



### 410A Micro-Shear® Flush Cutter

Ultra flush cutting version of our 410, for fine work. Very lightly bevelled cutting edges allow for minimal blade by-pass (see diagram) ensuring the finest flush cut possible while still retaining the Micro-Shear® blade by-pass type of cut. Glare eliminating black finish and ergonomically shaped, non-slip Xuro-Rubber™ grips for operator comfort. Cuts soft wire up to 20 AWG (0.8 mm)

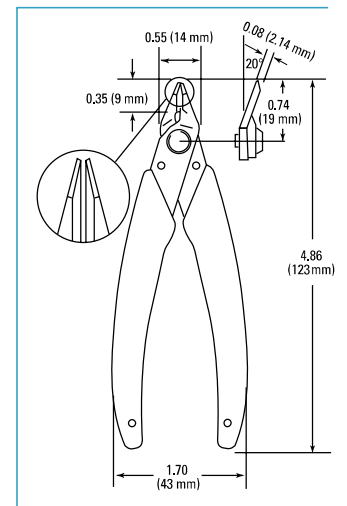
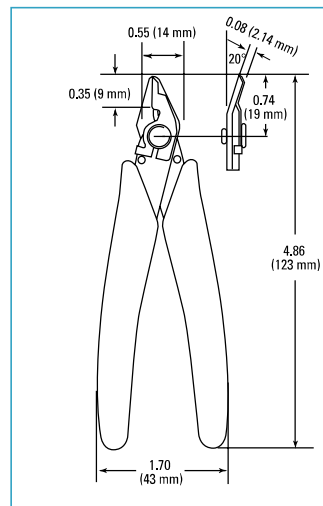
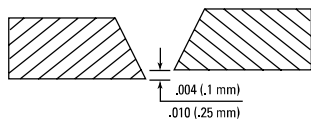
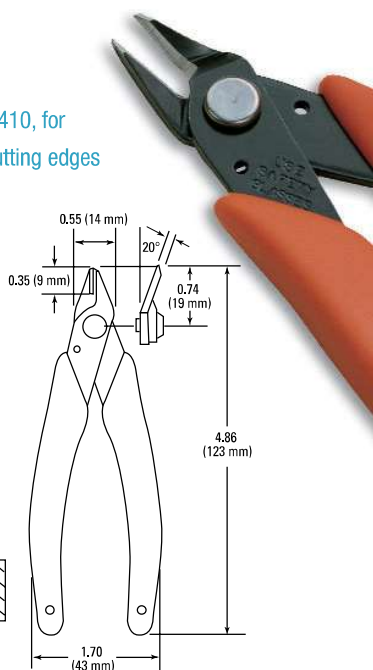

FEATURING QUALITY & PRECISION