

170-II Series Micro-Shear® Flush Cutters 11

return spring. Manufactured from a tough alloyed steel, their Rockwell hardness is a durable 54-56C. They are optionally available with static control (AS) grips.

635 Shear Rise Cutter

The 635 Shear Rise Cutter combines a full flush, shear cut and a 0.035" stand off in one cut. It's ideal for manufacturers who need both a stand off and a full flush cut. Glare eliminating black finish, ultra light weight and ergonomically-shaped, non-slip Xuro-Rubber™ grips ensure operator comfort. High carbon steel guarantees durability. Full flush cuts on soft wire up to 20 AWG (0.8 mm).

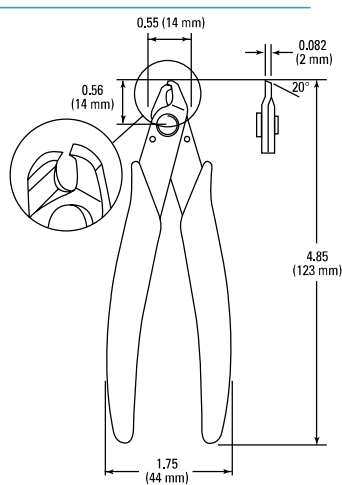

670 Cut and Crimp Tool

The 670 Cut and Crimp Tool features a slim profile (0.085") that allows accessibility in high density areas and provides excellent sight lines for precise positioning. Swaged leads are firmly attached to p.c.b., while freshly exposed lead material enhances solderability. High carbon steel guarantees durability. Ultra light weight, glare eliminating black finish and ergonomically shaped, non-slip Xuro-Rubber® grips ensure operator comfort. Cuts and crimps soft wire up to 20 AWG (0.8 mm). **Best results are achieved when the diameter of the hole on the p.c.b is not larger than 2.5 times the diameter of the wire being cut/crimped.**

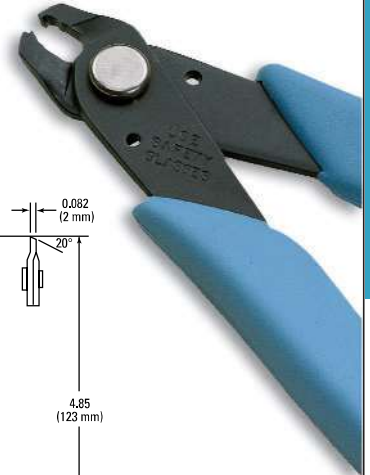
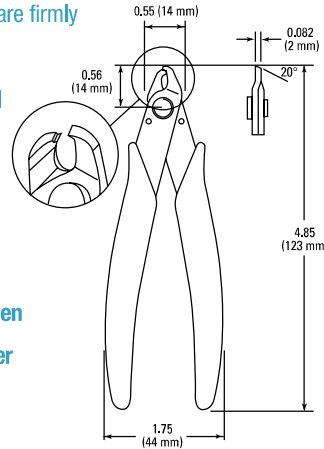

670HD Heavy Duty Cut and Crimp Tool

The 670HD offers the same great features as our 670 Cut and Crimp tool in a heavy-duty configuration. A larger head (0.115") simplifies positioning and heavy-duty construction provides extended tool life and larger wire capacity. Light weight, glare-eliminating black finish and ergonomically-shaped, non-slip Xuro-Rubber™ grips ensure operator comfort. Cuts and crimps soft wire up to 16 AWG (1.27 mm). **Best results are achieved when the diameter of the hole on the p.c.b is not larger than 2.5 times the diameter of the wire being cut/crimped.**

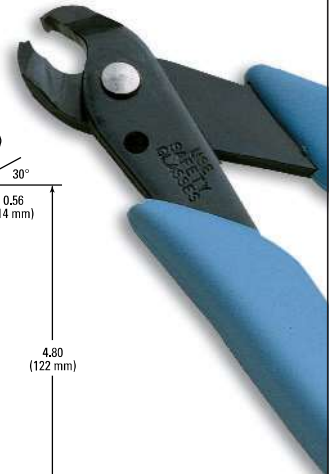
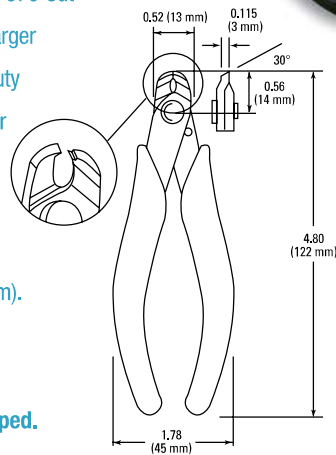

8500 BioShear® Flush Cutter

Bio-Shear® flush cutters incorporate the popular curved grip design with all the ergonomic features of our standard 170-II. Grip design keeps the knuckles of the operator's hand in a straighter line and prevents the hand from completely closing, reducing the amount of effort expended while delaying fatigue. Heat treated to 54-56RC for lasting durability. Please designate either 8500L(left) or 8500R(right).

