

INSTRUCTION MANUAL

MODEL : AW-47  
NAME : LABORATORY WASHER

YAMATO SCIENTIFIC CO., LTD.

## CONTENTS

	Page
[I] SPECIFICATIONS -----	1
[II] EXTERNAL VIEW -----	3
[III] PRINCIPLES AND CONSTRUCTION -----	4
[IV] WIRING DIAGRAM -----	6
[V] WASHING METHOD -----	8
[VI] HOT WATER -----	10
[VII] RACKS (Optional Accessories) -----	12
[VIII] OPERATION -----	17
[IX] REMARKS ON HANDLING -----	25
[X] TROUBLESHOOTING -----	27
[XI] PARTS LIST -----	30
[XII] DRAWING FOR PIPING -----	31

[I] SPECIFICATIONS

Washing method	:	Up and down two directional water jet method Jet nozzle rotation (replaceable with jet rack)
Supply water temperature	:	Room temperature to 80°C
Water heating method	:	Heating by built-in heater (1 kW) or hot water piping
Supply water pressure	:	1 to 3 kg/cm <sup>2</sup>
Supply and drain method	:	Use of solenoid valve for supply water, and natural draining for drain water
Apparatus to be washed	:	Glassware other than pipette (Height: up to 300 mm)

Construction

Washing tub material	:	Stainless steel plate (SUS304)
External dimensions	:	450W x 490D x 775H mm
Pump	:	AC100V, w/trans.
Glassware table	:	ø420 mm (rotary table)
Door	:	Up-down door
Weight	:	Approx. 40 kg
Power source	:	AC100V, w/trans.

Accessories

Vinyl cover	:		1
Water supply hose	:	9.5 mmID x 2 m (with one-touch coupler)	1
Drain hose	:	25.4 mmID x 1.5 m (with fitting)	1
Feed water unit	:	With accessories	1
Grounding adapter	:		1

Non-standard accessories

Jet rack	:		1
Test tube rack	:	(Set of four)	1
Detergent (Murin Luster)	:	(Can of 10 kg)	1

[II] EXTERNAL VIEW

- ① Up-down door
- ② Water supply port
- ③ Drain port
- ④ Main switch
- ⑤ Timer

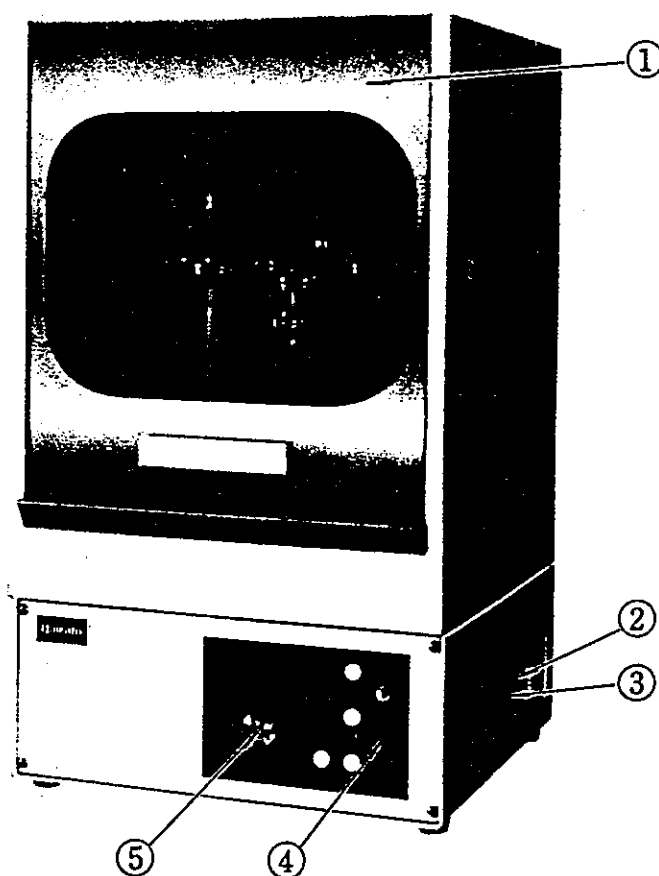

[III] PRINCIPLES AND CONSTRUCTION

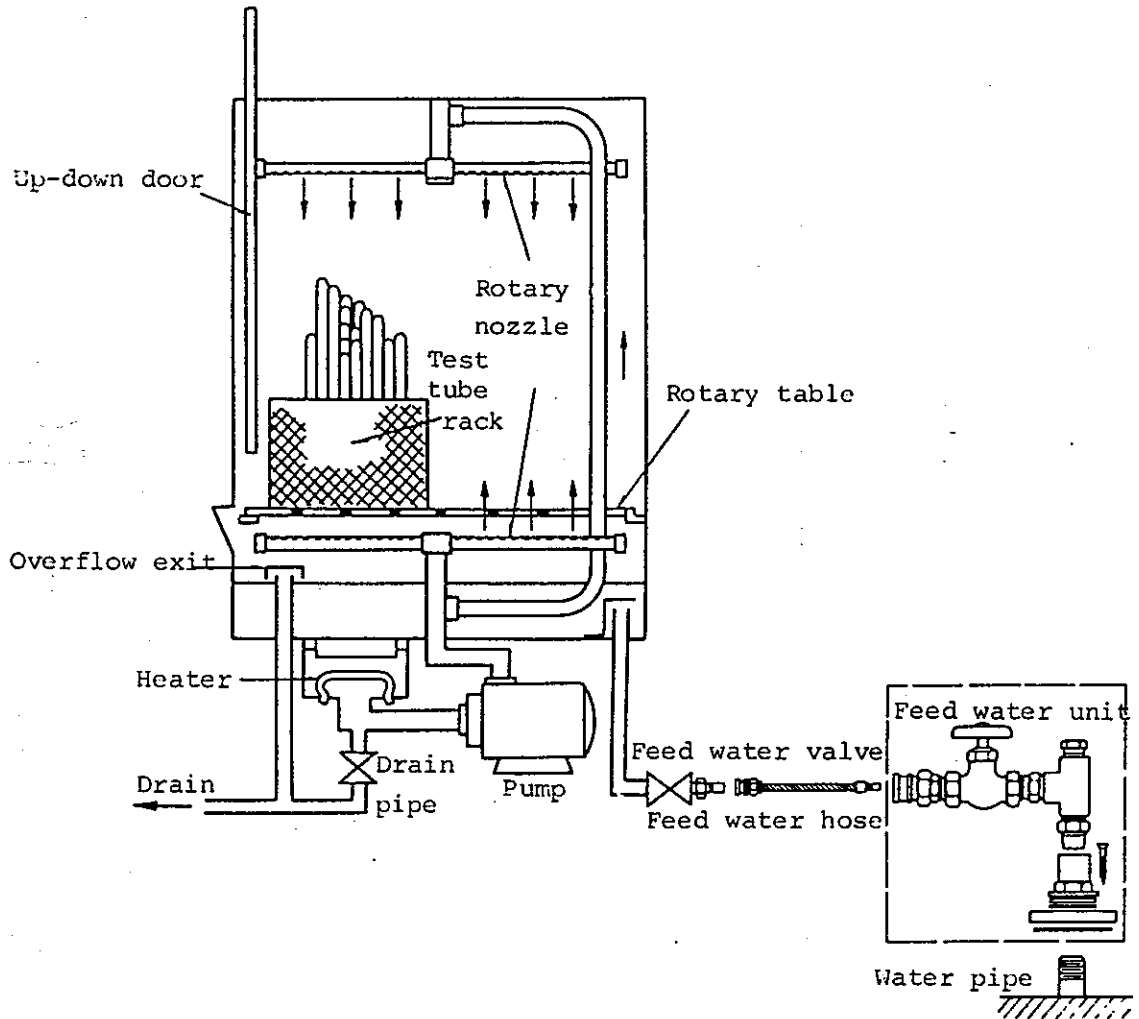

The Laboratory Washer has the three washing processes of Pre-washing, Washing with detergent and Rinsing, and any process can be selected and operated according to the situation.

Water is fed into the Washer through the feed water valve, and the Washer is operated for a period of time set on the Timer by operating the pump. The operations are manual, and draining and rinsing may continue after washing or next washing may continue without draining selecting the operation manually depending on the situation.

Pressured water is ejected from the upper and lower rotary nozzles, and inside and outside of glassware can be washed completely.

[ IV ] WIRING DIAGRAM

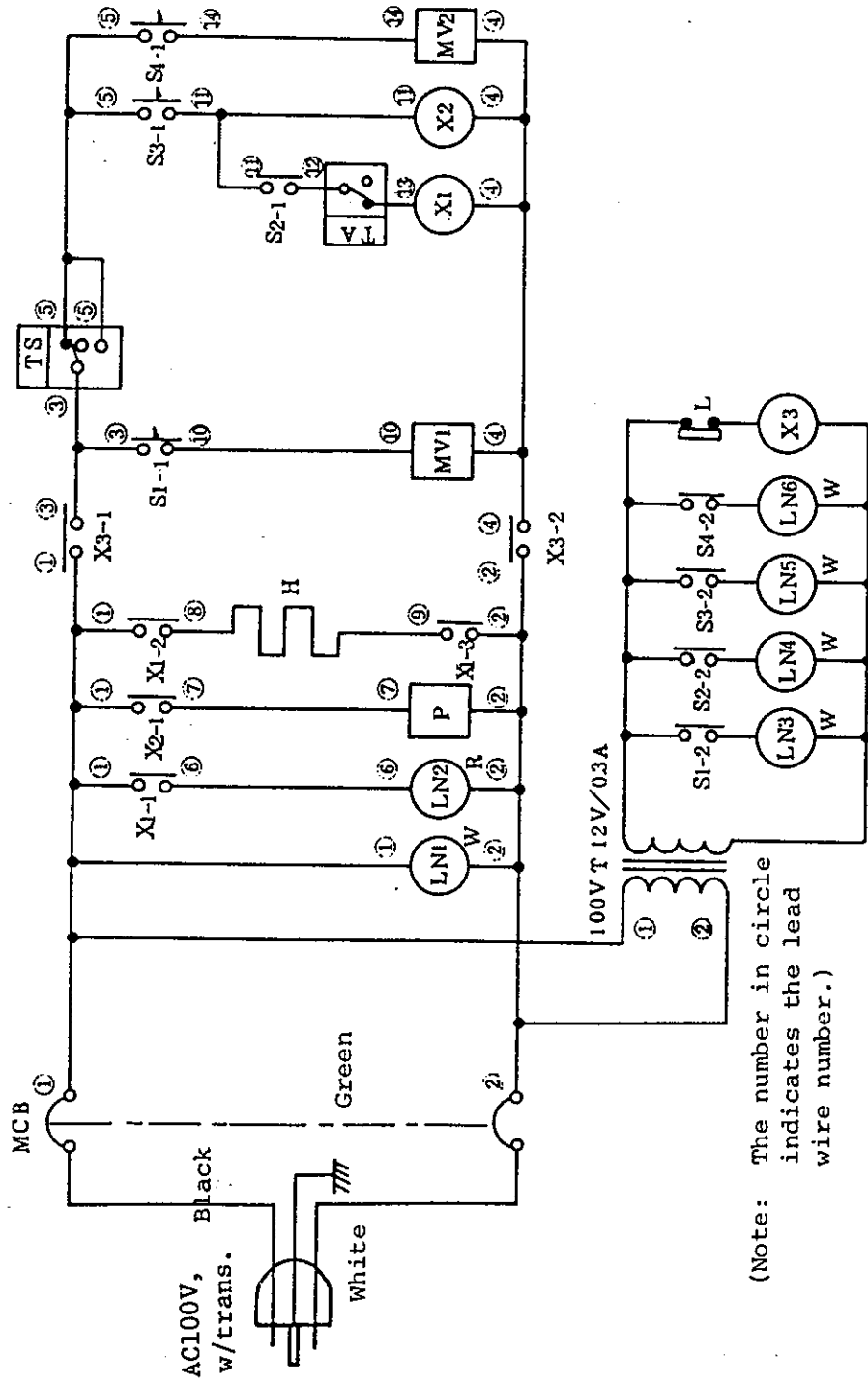



Symbol	Part name
MCB	Power switch and circuit breaker (for power supply)
H	Heater (for heating water)
P	Pump
MV1	Solenoid valve
MV2	Solenoid valve
S1	Switch (for drain)
S2	Switch (for heater)
S3	Switch (for pump)
S4	Switch (for feed water)
TA	Temperature controller
LN1	Lamp
LN2	Lamp
LN3	Lamp
LN4	Lamp
LN5	Lamp
LN6	Lamp
X1	Electromagnetic contactor
X2	Electromagnetic contactor
X3	Relay
T	Transformer
L	Lead switch
TS	Spring timer

[V] WASHING METHOD

The washing time and the rack must be selected according to the kind of glassware, the kind of stains and the level of stains in order to achieve higher washing effectiveness.

Actual Examples Practiced at Yamato

Test tubes, (measuring) flasks and beakers are set on the test tube racks, jet racks and round nets, respectively.

(1) Water-soluble stains (such as ink and sauce)

[Washing conditions]

- o Heater : OFF
- o Detergent : Unused (Overflow rinsing with feed water valve ON)
- o Timer setting : 15 minutes

(2) Oil stains (such as machine oil and vegetable oil)

[Washing conditions]

- o Heater : ON
- o Detergent : 25 g (Murin Luster)
- o Timer setting : 30 minutes

After washing with detergent, the feed water valve is turned to ON for overflow rinsing. The time of overflow rinsing is about 15 minutes.

(3) Protein containing stains (such as milk stains)

[Washing conditions]

- o Heater : ON
- o Detergent : 25 g (Murin Luster)
- o Timer setting : 30 minutes

The feed water valve is turned to ON for overflow rinsing after washing. The time of overflow rinsing is about 15 minutes.

Note that solid stains on glassware must be removed by brushing before washing. Agar stains often clogs solenoid valves, and they must especially be removed by brushing before washing. In addition, do not use a foaming detergent or a detergent which contains insoluble components such as cleanser. Do not also use organic solvents.

The examples given above are those practiced at Yamato. Glassware stains, however, are rich in variety. If washing results are not satisfactory using conditions shown in examples, please change conditions such as longer timer setting for better results.

[VI] HOT WATER

(1) Heating by built-in heater

The heating of water by the built-in 1-kW heater begins when the pump starts to operate if the heater switch is turned to ON. The relations between the heating time and the water temperature are as shown in the figure given below.

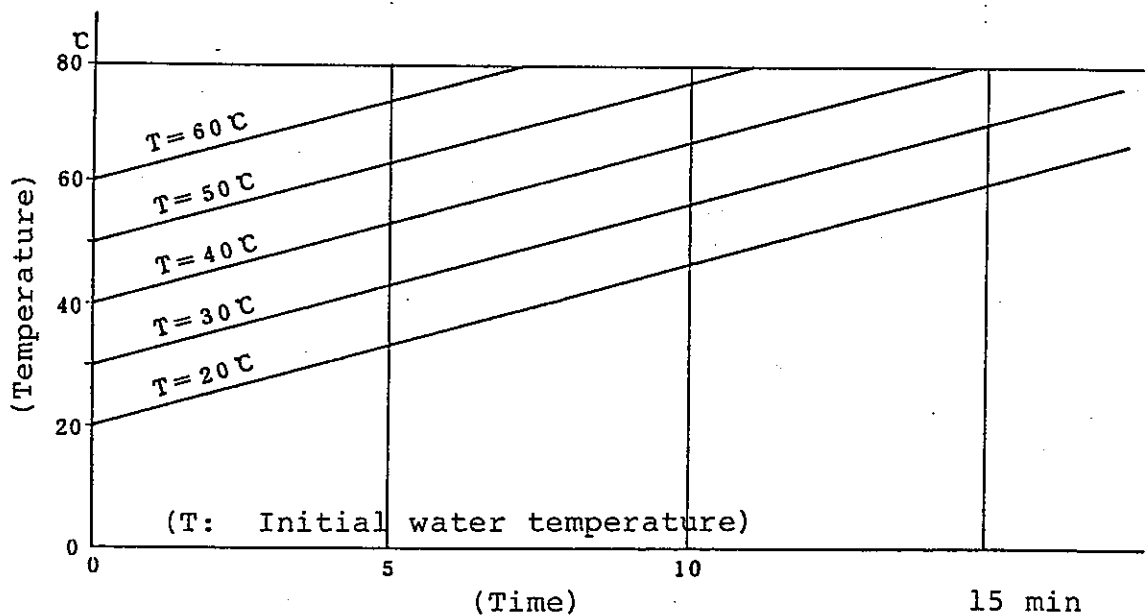

The heater operates only when the pump operates. The temperature is controlled by a thermostat, and its specifications are as follows:

- Type : CS-7
- Temperature setting :  $75 \pm 5^\circ\text{C}$
- Temp. difference between ON and OFF :  $15\text{--}25^\circ\text{C}$

(2) Heating by steam

If hot steam is to be mixed in the common water for supplying hot water, install check and relief valves to prevent reverse flow of steam or excessive high pressure. It is also necessary to carefully design piping so that excessive steam is supplied to the Washer.

[VII] RACKS (Optional Accessories)

There are two kinds of optional racks: test tube rack and jet rack.

(1) Test tube rack (made of SUS304)

In setting various test tubes in the rack, make sure to set them vertical and opening down.

The rack consists of four sections so that test tubes can be set with ease when the number of test tubes to be washed is rather small. Each section may be placed in a small-sized dryer after washing to dry test tubes as they are.

Rack capacity : About 450 test tubes (16.5 mm $\phi$ )

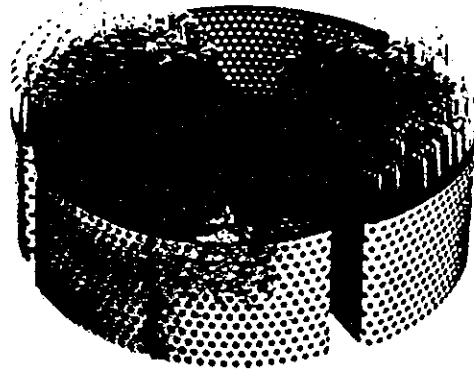

Test Tube Rack

(2) Jet rack

The jet rack is convenient for washing flasks. It is made of SUS304 stainless steel and some polyethelene and silicone rubber.

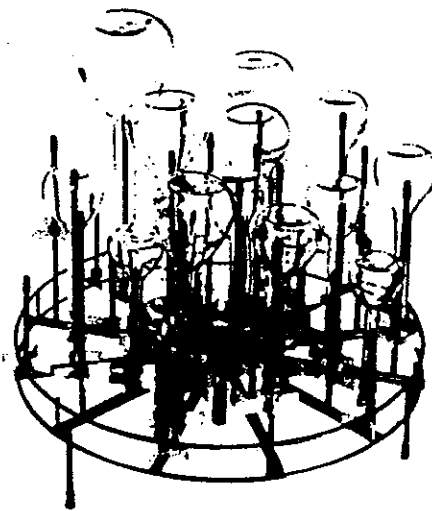

Jet Rack

(a) How to mount the jet rack

Washer

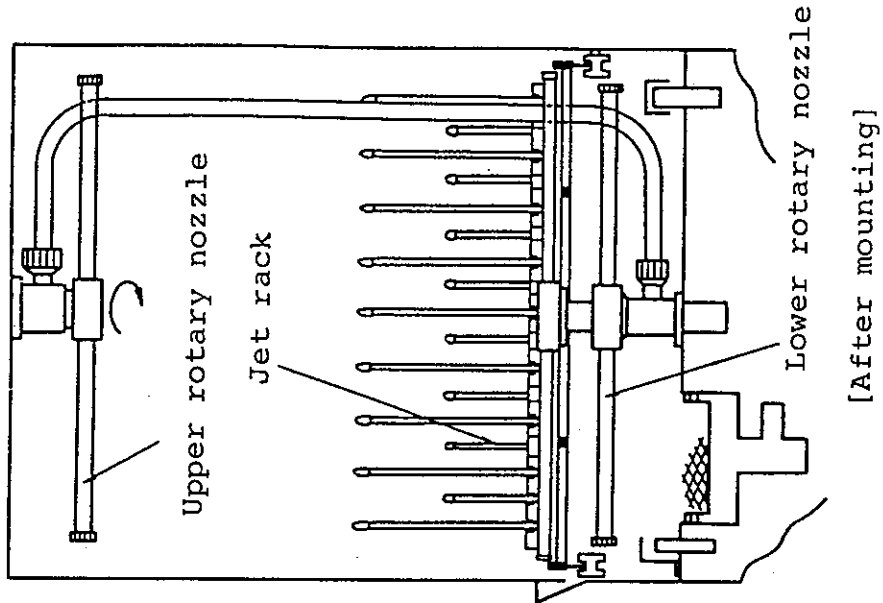
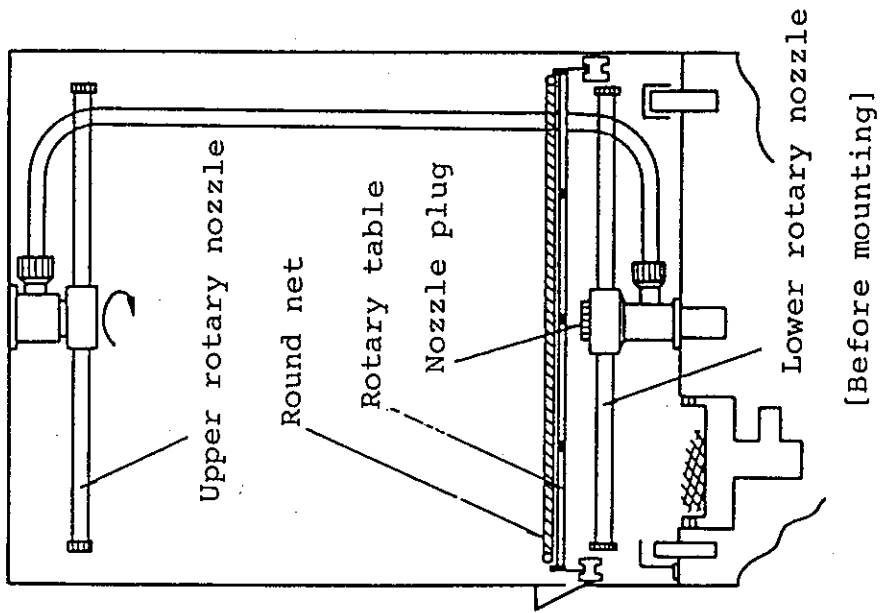



In mounting the jet rack, remove the round net of the Washer and then remove the nozzle plug existing at the center of the lower rotary nozzle. Then, place the jet rack on the rotary table by setting its lead tube in the hole existing after the nozzle plug is removed.

(b) Capacity

Measuring flasks (100 ml or smaller)	:	36
(250 ml)	:	About 20
(500 ml)	:	About 12
(1000 ml)	:	About 5

The glassware support of the nozzle pin is movable up and down for height adjustment, and adjust the glassware support according to the size of glassware. In adjusting the height, adjust it so that the nozzle cap position is at about the center of gravity of the glassware as illustrated below. (In adjusting, make sure to move the support gently so that it does not come apart.)

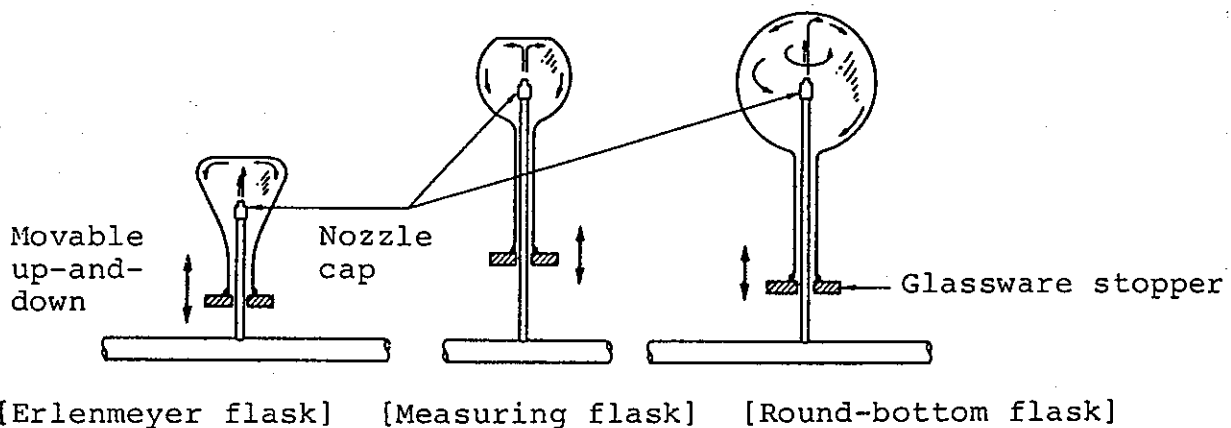

Glassware of up to 300 mm high can be set, but it may not possible sometimes to set larger glassware when the jet rack is kept mounted on the Washer. If such is a case, take out the jet rack once, set glassware on the jet rack outside the Washer, and mount the jet rack with glassware again on the Washer.

[VIII] OPERATION

- (1) Connect the feed water port existing on the right side of the Washer and a city water tap using the feed water hose found in the accessories in the following procedure. Note that the pressure of city water must be in the range of 1 to 3 kg/cm<sup>2</sup>.

The water cock of the city water must be removed in the feed water hose connection, and make sure to close the city water main valve before starting the operation.

- (a) Remove a water cock near the Washer, and attach the water feed unit as shown in the figure given below.

Make sure to apply sealing tape at places indicated with \*.

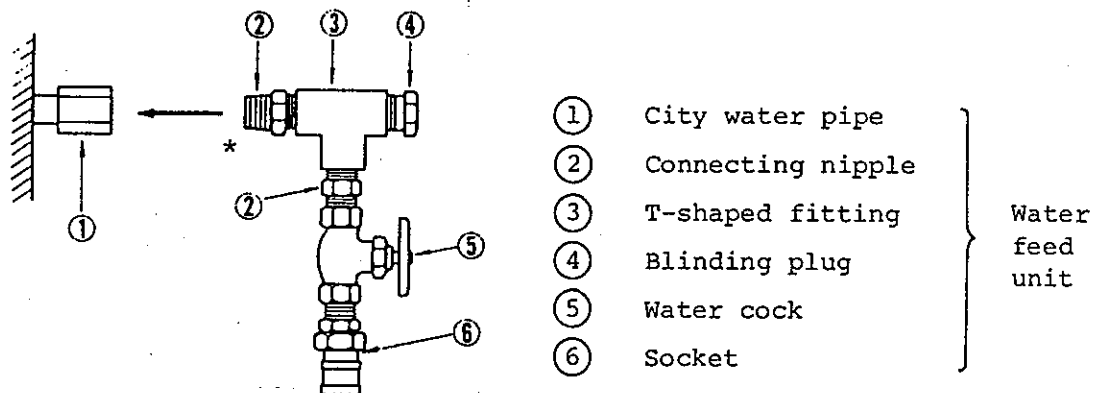

Wall type connection

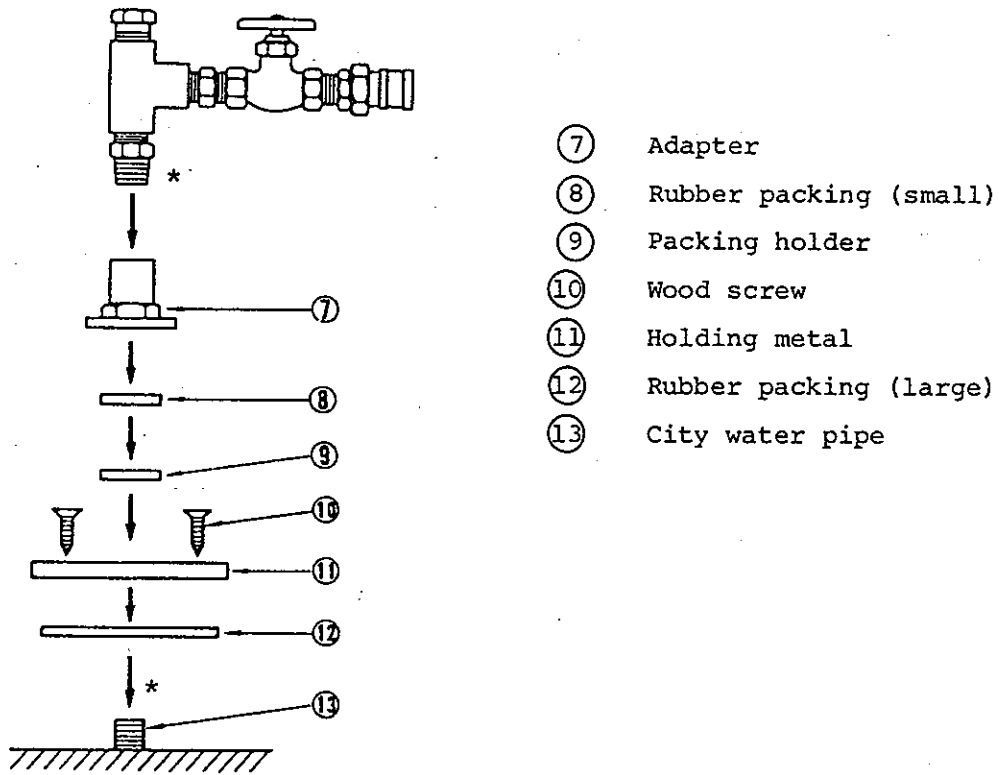

Floor type connection

(b) The original water tap can be connected to the water feed unit by removing the blinding plug. Use only a one or two-tap faucet considering the strength of the connection. Make sure to use sealing tape to places indicated with \*.

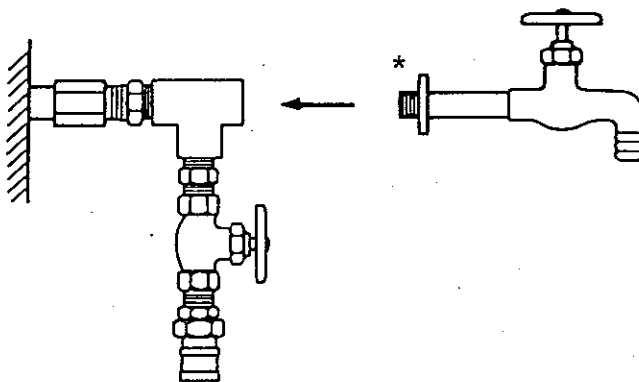

Wall type

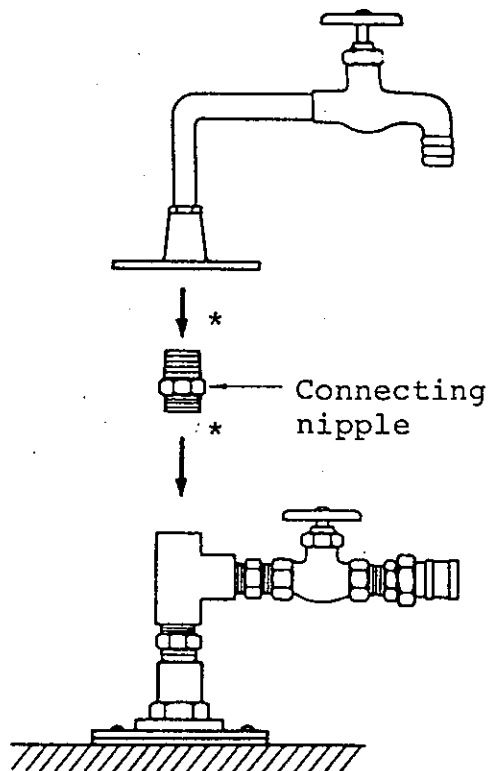

Floor type

- (c) Connect the water feed unit and the feed water solenoid valve of the Washer with the attached feed hose. One-touch connectors are equipped to the hose, and firmly fix the connections as indicated in the figure.

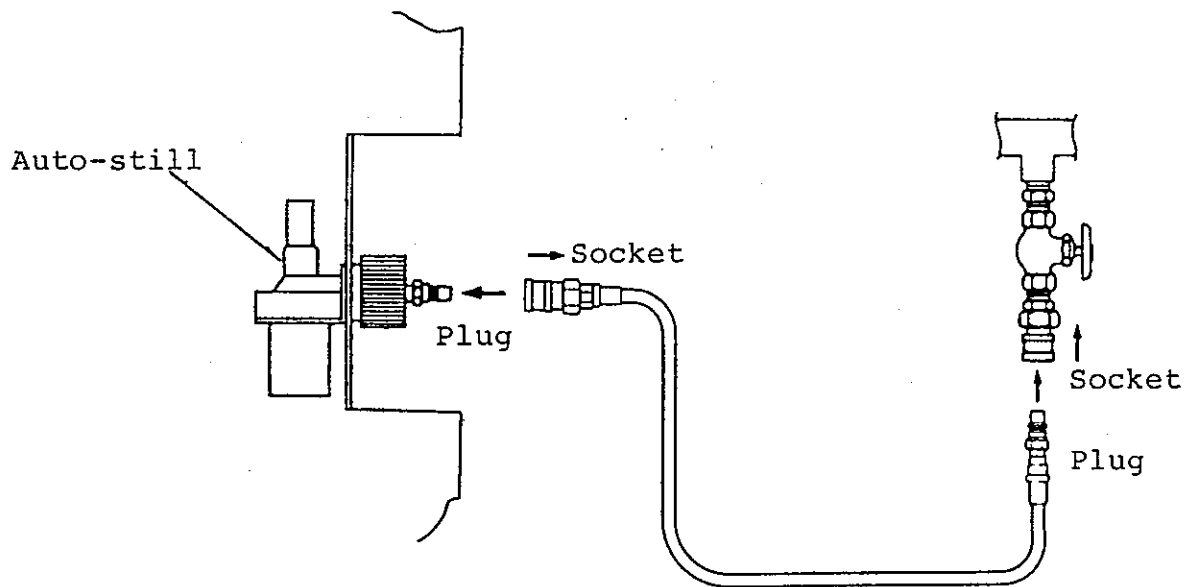

- (d) Open the main valve of the city water, and confirm that no water leaks at connections.
- (2) Connect the attached drain hose with exhaust outlet of unit and with drain hole. Fix the other end of the hose at a drainage area. Shorten the length of drain hose as far as possible not to cause bending of the hose.

- (3) After confirming that the power switch is turned off, connect the power cord properly to the power source of 100 V and capacity of 15 A or more.

The power cord of the unit is a 3P cord including the earth wire, and the plug is also a grounded type plug. If the receptacle of the power outlet does not match the plug, the grounding adapter provided as an accessory must be used.

Make sure to connect the earth lead wire to a grounding facility when the grounding adapter is used.

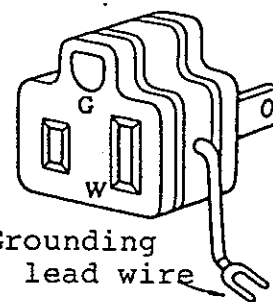

Grounding adapter

- (4) Set the glassware to be washed to the round net or the rack.
- (5) In washing with detergent, put about 25 g (0.5%) of detergent (Murin Luster, preferably) in the vessel.

- (6) Turn the power switch to ON, and the POWER lamp (red) lights up.

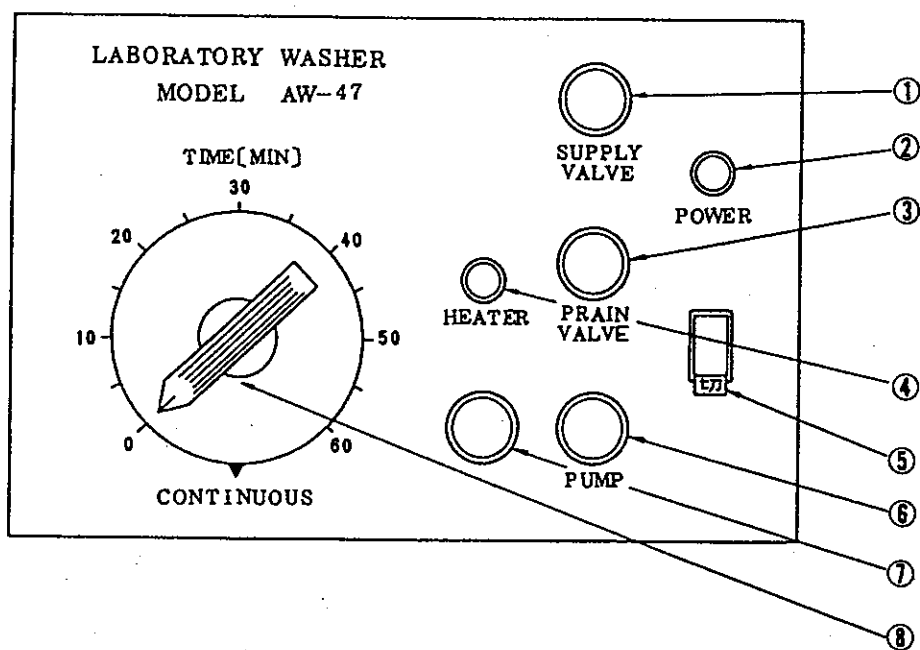

[Front Panel]

- ① Feed water valve switch
- ② POWER lamp
- ③ Drain valve switch
- ④ Heater lamp
- ⑤ Power switch
- ⑥ Pump switch
- ⑦ Heater switch
- ⑧ Timer (0-60 min)



- (7) Then, set the timer.

Note: The timer allows to set in the range of 0 to 60 minutes without regard to the line frequency of 50 Hz or 60 Hz. If it is set to CONTINUOUS, in addition, continuous washing is made in the washing process irrespective of the timer setting.

- (8) Turn the SUPPLY VALVE switch to ON to supply water. The vessel will be filled with water after a certain time, and excessive water is drained from the overflow outlet. Then, turn the SUPPLY VALVE switch to OFF.

(Keep the SUPPLY VALVE switch at ON in the rinsing process.)

- (9) Turn the PUMP switch to ON to start the pump and washing. Then, turn the HEATER switch to ON. Note that all switches will be turned off if the door is opened during operation. Thus, it allows to add more to be washed or to check the Washer.
- (10) When the time set on the timer passes, the pump stops automatically, and washing with detergent ends.

Set the timer again and turn the SUPPLY VALVE switch to ON to start rinsing. The effectiveness of rinsing will be rather low and it will take a longer time to rinse if the amount of water supply is small. Make sure to supply sufficient amount of water (on the order of 20 l/min) for better rinsing.

- (11) The pump stops automatically when the time set on the timer passes, and the rinsing process ends. Turn the DRAIN VALVE switch to ON to drain.

Note: Do not turn the DRAIN VALVE switch to ON while the pump is operating, or bubbles will be sucked into the chamber.

[IX] REMARKS ON HANDLING

- (1) The water cock and the feed water hose must be connected at a place where a draining facility is provided.
- (2) The city water pressure must be in the range of 1 to 3 kg/cm<sup>2</sup> (including during the night).
- (3) Make sure to keep the water cock closed when the Washer is not to be operated such as during the night and holidays.
- (4) Make sure to replace supply and drain hoses and internal piping hoses with new ones within 2 years. Make sure to replace a hose any time when degradation is observed. Perform periodic inspections on connections especially when the water pressure changes much.
- (5) In replacing hoses and other parts, use those which conform to Yamato's specification.
- (6) Screw-in the cap-nut portion of drain hose firmly to the drain port of the Washer, and fix the other end of the hose at a place where water can be drained. Cut the drain hose to a necessary length, and be careful not to bend the hose.

- (7) Make sure to connect the grounding lead wire to a grounding terminal when the grounding adapter is used.
- (8) Be very careful in opening the Washer because it gets very hot inside.
- (9) Do not use foaming detergent or detergent such as cleansers which contain insoluble components.  
Never use organic solvents in the Washer.
- (10) All operation stop when the door is opened during operation. Open the door carefully because water may splash due to the remaining pumping pressure if the door is opened abruptly.
- (11) Keep caution cards at the water feed unit and at the Washer.

[X] TROUBLESHOOTING

(1) Insufficient cleaning

[Causes]

- (i) Clogged rotary nozzle
- (ii) Timer setting too short
- (iii) Faulty pumping
- (iv) Water temperature is too low (faulty heater)
- (v) Insufficient or degraded detergent
- (vi) Improper glassware setting

[Remedies]

The causes of insufficient cleaning can be judged from the washing performance such as insufficient or no cleaning. The glassware will be cleaned little when the nozzle does not rotate due to clogging or when the washing water has little pressure due to faulty pump. Insufficient cleaning will result when the washing time is too short, when the water temperature is too low due to broken heater or when the detergent has been degraded. Correct faulty portions, and obtain proper washing performance.

(2) Insufficient rinsing

[Causes]

- (i) Clogged rotary nozzle
- (ii) Timer setting too short
- (iii) Faulty pumping
- (iv) Water flow too low
- (v) Improper glassware setting

[Remedies]

The causes for insufficient rinsing are similar to those of insufficient cleaning except that water flow is an important factor in rinsing. Water feeding and draining are carried out at the same time by overflowing, and it will take a long time to replace the rinsing water with clean water if the water flow is low. A water flow on the order of 20 l/min is considered to be sufficient. (The time required to fill the vessel and begin to overflow from the drain port is about 20 seconds at this water flow rate.)

- (3) The rotary nozzle does not rotate or rotates too slow (less than 5 times per minute).

[Causes]

- (i) Circumferential nozzles clogged
- (ii) Faulty bearing, or something got into the bearing.
- (iii) Pressure of supply water is too low or water flow is too low.
- (iv) Rotary nozzle is hitting something.

[Remedies]

The nozzle in normal condition turns 10 to 15 times per minute. If the rotary nozzle does not rotate even when water is gushing vertically, the cause must be (i), (ii), or (v). Try and turn the rotary nozzle by hand. If trouble in bearing is suspected, take out the rotary nozzle and repair or replace the rotary nozzle. The rotary nozzle does not turn when the amount of water is low (as against normal 5 ℓ) or when bubbles are included in the pump, and add some water.

(4) Miscellaneous

Feeding and draining troubles due to clogged feed water or drain solenoid valves may occur in extreme cases. If such is the case, repair or replace the faulty solenoid valve.

[XI] PARTS LIST

Parts name	Parts number	Specifications
180° elbow	291012-133	Hard glass (Yamato)
90° elbow	-134	Hard glass (Yamato)
Heater	-146	1 kW, SUS316 (Yamato)
Handle collar	-153	Black bakelite (Yamato)
Magnet	-201	Ferrite (Daichi Magnet)
Door glass	-202	Heat-resistant glass (Yamato)
Bearing	-303	SUS440C, A-2520F (MMB)
Oil seal*	-304	ZF No. 3 (Nippon Oil Seal)
Breaker	-315	BS2022 (Matsushita Denko)
Switch (white)	-316	KLS-25, 2a2b (Kimden)
Lamp	-317	T-4.5, 12V (Kimden)
Spring timer	-318	SC-2-1H-1a (Zenkosha)
Lead switch	-319	RD-3-50 (NEC)
Solenoid valve	-302	J240-130 for feeding (CKD)
Solenoid valve	-322	J241-122 for draining (CKD)
Transformer	-324	HT-1203 (Toyozumi)
Electromagnetic contactor	-330	FC-0T 1a 100V (Fujidenki)
Relay	-332	AP3121 (Matsushita Denko)
Pilot lamp	-334	BN5701 (Sato Parts)
Temperature controller	-335	CS-7, 75±5°C (Fukushima Dengyo)

Note: Parts indicated with \* are consumables.



[XII] DRAWING FOR PIPING

