

SINCE 1889



Large capacity (37L) constant temperature oil bath with excellent temperature distribution accuracy.

Oil Bath

BOA201/311

Large capacity oil bath with safety design

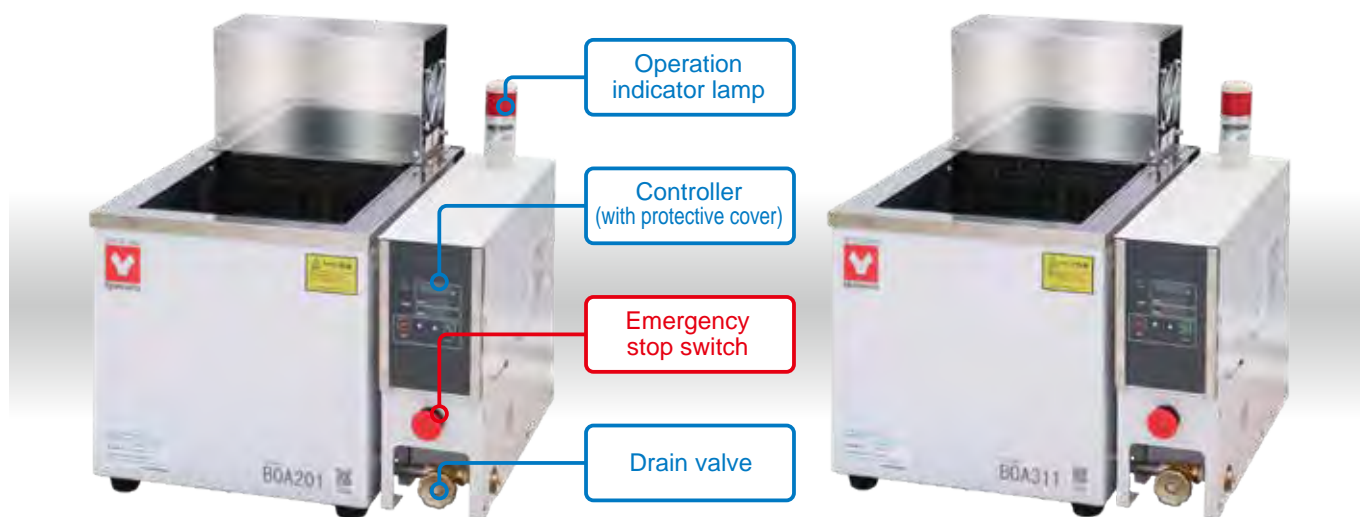

BOA201

BOA311

Features

- Large capacity oil tank (37L) to process large volume of samples.
- Designed with a shelf board that changes tank height depending on application. (11 steps with 20mm pitch)
- High temperature distribution accuracy of $\pm 0.2^{\circ}\text{C}$ is through jet stirring.
- Standard equipped with external alarm output, temperature output, and RS485 terminal.

Safety and security functions

- Designed with triple overheat protection function.
 - ① Automatic overheat prevention control at set temperature $+6^{\circ}\text{C}$ (controller)
 - ② Set the upper temperature limit to any desired temperature. (controller)
 - ③ Independent overheat protection device. (maximum temperature $+30^{\circ}\text{C}$ fixed)
- Large operation lamp to indicate high temperature operation.
- Designed with an emergency stop switch to forcibly shut off the equipment breaker in an emergency.
- Oil level detection at the upper and lower limits prevents empty firing and overflow.



Precautions for use

Silicone oil and other oily smokes are flammable, use bath it where there is an exhaust device such as a fume hood.



Specifications

Model	BOA201	BOA311	
Product code	222114	222116	
Stirring method	Jet stirring		
Performance*2	Temp. control range	RT+10 to 200°C	RT+10 to 270°C
	Temp. adjustment accuracy	±0.1°C (at 200°C, Silicone oil, JTM K05)	
	Temp. fluctuation	0.2°C (at 200°C, Silicone oil, JIS)	
	Temp. distribution accuracy	±0.2°C (at 200°C, Silicone oil, JTM K05)	
	Temp. gradient	0.5°C (at 200°C, Silicone oil, JIS)	
	Max. temp. reaching time	Approx. 120 min.	Approx. 70 min.
Configuration	Exterior	Chrome-free electrogalvanized steel sheet with baked finish	
	Inner bath	Stainless steel plate	
	Heater	Pipe heater, SUS316	
		2kW	4.5kW
Stirrer	Vertical propeller stirring		
	Induction motor, 25W		
Controller	Controller	VS6 type	
	Temp. control method	PID control	
	Display resolution	0.1°C	
	Operation functions	Fixed temp. operation (with operation indicator lamp)	
	Other functions	Drain valve/Large operation indicator lamp/ External alarm output terminal/Temp. output terminal (1 to 5V, 4 to 20mA switching type)/ RS485 communication function/Calibration offset function/ Set value lock function/Power failure compensation function	
		Sensor	Platinum resistance thermometer Pt100Ω (for temp. control)/ K Thermocouple (for overheat protection device)
Safety Features	Self-diagnosis function (automatic overheat protection/ temperature sensor error/heater disconnection/ SSR short circuit/main relay failure/memory error/ internal communication error/measurement temp. error/ empty burning abnormal/water level error)/ Overheat protection device/Independent overheat protection device (BOA201 230°C, BOA311 300°C fixed)/ Overcurrent leakage breaker/Emergency stop switch		
Standard	Effective internal dimensions	W296×D340×H270mm (Height when the lowest shelf board is attached from the top of the inner bath)	
	Shelf in the bath Number of steps/pitch	11 steps / 20mm	
	External dimensions*2	W531×D520×H578mm (Height in the bath: 397mm)	
	Bath capacity	Approx. 37L (Amount of oil up to 50mm from the top of the bath)	
	Power source	AC220V 10A Single phase with step-down transformer	AC220V 21A Single phase with step-down transformer
Accessories	Weight	Approx. 37kg	
	Shelf	1 pc.	
	Lid	1 pc.	
Instruction manual	1 copy		

*1 The operating environment temperature range is 5 to 35°C.

*2 Do not include protrusions

Option

Model	OA017
Product code	281146
Product name	External communication adapter set
Specification	RS485 (device) ⇔ USB2.0 converter (PC)

Exterior view of shelf plate

Shelf plate capable of changing depth according to sample

11 Steps / 20mm pitch
Lowest Depth: 270 mm

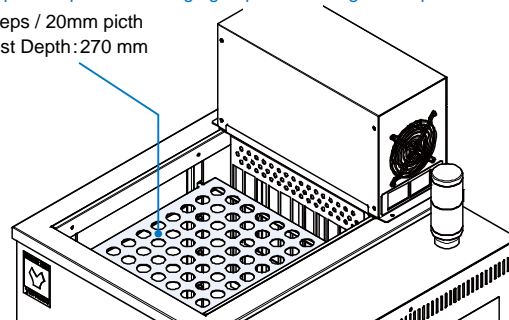

Lid (standard accessory)



Q&A BOA201/311

Q What is the recommended oil to use?

Silicone oil is recommended.
TSF 458-50 when used below 200°C. TSF 458-100 is recommended when operating at 200 to 270°C. Select a viscosity of 100mm²/s or less.



The specifications and performance figures of the products listed in this catalog are presented as a user guide under general operating conditions. When using the product, please understand the contents of the instruction manual and use the product correctly. Please note that we cannot be held responsible for any damage to persons or property caused by using the product outside the conditions of use described in the instruction manual.

•Specifications and appearance are subject to change for improvement without prior notice. •The product colors may appear different from the actual colors due to the shooting and printing inks.
•Company names, product names, and logos are trademarks or registered trademarks of our company Corporation or of their respective owners.

SINCE 1889



For the development of scientific technologies

Yamato Scientific Co., Ltd.

www.yamato-scientific.com

Yamato Scientific Co., Ltd.

International Sales Department :

Harumi Island Triton Square Office Tower Y, 36F

1-8-11 Harumi, Chuo-ku, Tokyo 104-0053, Japan

TEL: +81-3-5548-7122 FAX: +81-3-5548-0132

<Customer Service/Technical Support> english-website@yamato-net.co.jp

Yamato Scientific Shanghai Corp.

Room 1001-1002, Block B, Xinyan Building,
No.65 Guiping Road, Xuhui District, Shanghai, China
TEL: +86-21-6443-5319 FAX: +86-21-5452-0268

<Customer Service/Technical Support> info@yamato-shanghai.com

Yamato Scientific America Inc.

925 Walsh Ave. Santa Clara, CA 95050, U.S.A.

TEL: +1-408-235-7725 FAX: +1-408-235-7730

<Customer Service> customerservice@yamato-usa.com

<Technical Support > www.yamato-usa.com