

---

**User's  
Manual**

CL255  
Clamp-on Tester  
クランプテスタ

IM CL255

---

保証書付

---

**YOKOGAWA** ◆

横河計測株式会社

Yokogawa Test & Measurement Corporation

IM CL255  
2018.6 12 版 (KYOU)

# Contents

---

■ Precautions for Safety Use of the Instrument .....	i
1. Instrument Layout .....	1
2. Measurement .....	4
2.1 Preparation for Measurement .....	4
2.2 DC Current Measurement .....	4
2.3 AC Current Measurement .....	5
2.4 DC Voltage Measurement .....	6
2.5 AC Voltage Measurement .....	7
2.6 Resistance Measurement .....	8
2.7 Continuity Check (400Ω range fixed) .....	8
2.8 Frequency Measurement .....	9
2.9 Peak Measurement .....	10
2.10 Average Measurement .....	11
3. Other Functions .....	12
3.1 Sleep Function .....	12
3.2 Data Hold Function .....	12
3.3 LoHz Function .....	12
3.4 OUTPUT Terminal (For current ranges only) .....	13
3.5 Optional Accessories .....	14
4. Battery Replacement .....	15
5. Specifications .....	16
6. Calibration and After-sales Service .....	20

## ■ Precautions for Safe Use of the Instrument

When handling the instrument, ALWAYS observe all of the cautionary notes on safety given below. Yokogawa M&C Corporation is not at all liable for damage resulting from misuse of this product by the user that is contrary to these cautionary notes.

Various symbols are used on the instrument and in this manual to ensure the product is used safely and to protect operators and property from possible hazards or damage. The following safety symbols are used where appropriate. Read the explanations carefully and familiarize yourself with the symbols before reading the text.

The instrument and this manual use the following safety symbols:

Danger! Handle with Care.



This symbol indicates that the operator must refer to an explanation in the User's Manual in order to avoid the risk of personal injury or death and/or damage to the instrument.



Double Insulation

This symbol indicates double insulation.



AC Voltage/Current

This symbol indicates AC voltage or current.



DC Voltage/Current

This symbol indicates DC voltage or current.



AC/DC Voltage/Current

This symbol indicates AC/DC voltage or current.



Ground

This symbol indicates ground (earth)



Indicates that this instrument can clamp on bare conductors when measuring a voltage corresponding to the applicable Measurement category, which is marked next to this symbol.



### WARNING

---

---

Indicates that there is a possibility of serious personal injury or loss of life if the operating procedure is not followed correctly and describes the precautions for avoiding such injury or loss of life.

---

---



### CAUTION

---

---

Indicates that there is a possibility of serious personal injury or damage to the instrument if the operating procedure is not followed correctly and describes the precautions for avoiding such injury or damage.

---

---

## NOTE

Draws attention to information essential for understanding the operation and features.



## WARNING

- Never make measurement on a circuit above 750V AC or 1000V DC.
- Do not use the instrument in an atmosphere where any flammable or ex-plosive gas is present.
- Do not attempt to make measurement in the presence of flammable gas-es, fumes, vapor or dust. Otherwise, the use of the instrument may cause sparking, which can lead to an explosion.
- Avoid using the instrument if it has been exposed to rain or moisture or if your hands are wet.
- Do not exceed the maximum allowable input of any measurement range.
- Never open the battery compartment cover when making measurement.
- Do not use the instrument if there is any damage to the casing or when the casing is removed.
- Do not turn the Function Selector switch with plugged in test leads connected to the circuit under test.
- Do not install substitute parts or make any modification to the instrument. Return the instrument to Yokogawa Meters & Instruments or your distributor for repair or re-calibration.
- Always switch off the instrument before opening the battery compartment cover for battery replacement.
- Do not use the test leads that have deteriorated or are defective.
- Check the test leads continuity



## WARNING

To avoid damage to the instrument or electric shock!

The restrictions on the maximum voltage level for which the CL255 testers can be used, depend on the measurement categories specified by the safety standards. These category specifications are formulated to protect operators against transient impulse voltage in power lines.

Function	Maximum Allowable Input	
	MEASUREMENT CATEGORY II	MEASUREMENT CATEGORY III
$\sim A, \overline{=A}$	AC 2000A rms Measuring circuit voltage : AC 750V rms DC 1000V	AC 2000A rms Measuring circuit voltage : AC 600V rms DC 600V
$\sim V, \overline{=V}$	AC 750V rms/DC 1000V	AC 600V rms/DC 600V
Input terminal-to-ground voltage	AC 750V rms/DC 1000V	

O (None, Other)

Other circuits that are not directly connected to MEAINS.

Measurement category II (CAT.II)

Local level, appliance, portable equipment etc., with smaller transient over-voltages than CAT.III.

Measurement category III (CAT.III):

Distribution level, fixed installation, with smaller transient over-voltages than CAT.IV.



## CAUTION

---

---

- Always make sure to insert each plug of the test leads fully into the appropriate terminal on the instrument.
  - Make sure to remove the test leads from the instrument before making current measurement.
  - Be sure to set the Function Selector switch to the "OFF" position after use. When the instrument will not be in use for a long period of time, Place it in storage after removing the battery.
  - Use a damp cloth and detergent for cleaning the instrument. Do not use abrasives or solvents.
- 
- 

## NOTE

- Radiation immunity affects the accuracy of CL255 testers under the conditions specified in EN 61000-4-3.
- If equipment generating strong electromagnetic interference is located nearby, the testers may malfunction.

# 1. Instrument Layout

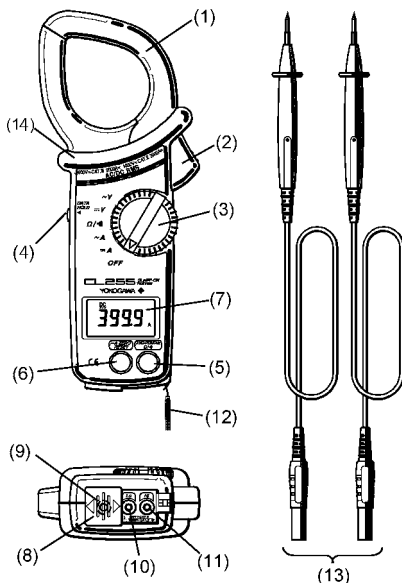

- (1) Transformer Jaws : Pick up current flowing through the conductor.
- (2) Open/Close Lever : Operates the transformer jaws. Press to open the Transformer Jaws.
- (3) Function Selector Switch : Selects function to use. Also switches off the instrument when set to "OFF" position.
- (4) Data Hold Button : Freezes the display reading. "H" is shown on the display when Data Hold is enabled.  
Note : When the plug is inserted into the output terminal, Data Hold Switch operates as range selection switch. (See section 3.4 OUTPUT Terminal)
- (5) Mode Selector Button : Selects measuring mode. The instrument defaults to the normal mode (NOR) Then, press this switch to cycle through measuring modes. In any mode, pressing this switch for more than one second returns the instrument to the normal mode.

$\sim A / \sim V$ (ACA/ACV)	Display	$\equiv A / \equiv V$ (DCA/DCV)	Display	$\Omega / \cdot \cdot \cdot$ (Resistance/Continuity)	Display
→ Normal ↓ Average ↓ Peak ↓ Frequency	<b>AVG</b>  <b>PEAK</b>  Hz	→ Normal ↓ Average ↓ Peak	<b>AVG</b>  <b>PEAK</b>	→ Resistance ↓ ↓ ↓ Continuity check	$\Omega$  $\cdot \cdot \cdot$

- (6) **FA ZERO RESET** Button : Used for zero adjustment on DCA and resistance ranges. Also used to reset the display reading in the PEAK mode. On DCA range, "AUTO" is shown on the display when auto-zeroing is completed. (Auto-zeroing is available on 400A range only.)
- (7) LCD Display : Field effect type of liquid crystal display with maximum counts of 3999. Function symbols and decimal point are controlled by the microprocessor based on the selected function and measuring mode.

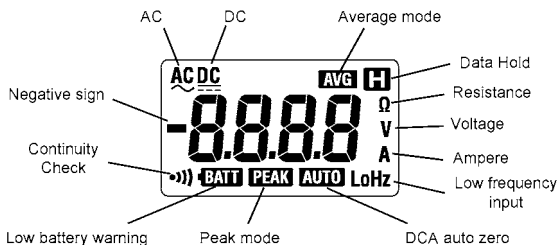

- (8) Terminal Cover : Slides over Hi and Lo Terminals to prevent access to them when OUTPUT terminal is in use.
- (9) OUTPUT Terminal (For AC or DC current range only) : Provides DC voltage output in proportion to the AC or DC current reading. (See section 3.4, OUTPUT Terminal.) output is connected to a recording device such as a chart recorder for long hour monitoring. No output is available on voltage and resistance ranges.
- (10) Lo Terminal : Accepts the black test lead for voltage or resistance measurement.
- (11) Hi Terminal : Accepts the red test lead for voltage or resistance measurement.

- (12) Safety Hand Strap : Prevents the instrument from slipping off the hand during use.
- (13) Test Leads (Model 98072) : Connected to Lo and Hi terminals for voltage or resistance measurement.
- (14) Barrier : It is a part providing protection against electrical shock and ensuring the minimum required air and creepage distances.



## 2. Measurement

### 2.1 Preparation for Measurement

#### CAUTION

- The jaw section is a delicate, precision sensor. Do not subject the jaw to unreasonably strong shock, vibration, or force when using it.
- If dust gets into the tops of the jaws, remove it immediately. Do not close the jaws when dust is trapped in its joints as the sensor may break.
- Please check that the Function Selector switch is set to the desired position before measurement.

### 2.2 DC Current Measurement

#### WARNING

- Do not make measurement on a circuit above 1000VDC. This may cause shock hazard or damage to the instrument or equipment under test.
- Do not make current measurement with the test leads connected to the Hi and Lo terminals.
- Keep your fingers and hands behind the barrier during measurement.

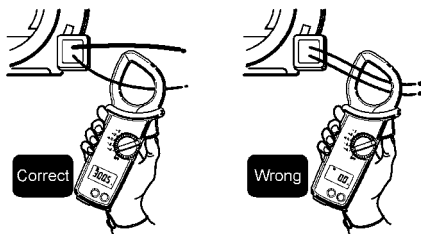

- (1) Set the Function Selector switch to the " $\text{DC} \text{ A}$ " position. "DC" should be shown on the upper left corner of the display.
- (2) With the transformer jaws closed and without clamping them onto the conductor, press the  button for about one second to zero adjust the display. (Zero adjust feature is for 400A range only.) When zero adjustment is completed, "AUTO" appears on the display.
- (3) Press the open/close lever to open the transformer jaws and clamp them onto the conductor under test, then take the reading on the display. The most accurate reading will be obtained by keeping the conductor at the center of the transformer jaws.

## NOTE

- During current measurement, keep the transformer jaws fully closed. Otherwise, accurate measurement cannot be made. The maximum measurable conductor size is approx. 55mm in diameter.
- When the current flows from the upside (the display side) to the underside of the instrument, the polarity of the reading is positive and vice versa.
- The **⊖A ZERO RESET** button may not completely zero adjust the output voltage from the OUTPUT terminal. In this case, make zero adjustment on the recording device.
- Turning the Function Selector switch to a position other than DCA cancels the zero adjustment.

## 2.3 AC Current Measurement

### WARNING

- 
- Never use the instrument on a circuit above 750VAC. This may cause electrical shock hazard and damage to the instrument or the circuit under test.
  - Do not make measurement with the battery compartment cover removed.
  - Keep your fingers and hands behind the barrier during measurement.
- 

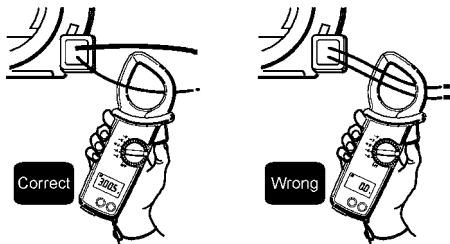

- (1) Set the Function Selector switch to the "  $\sim$ A " position. "AC" should be shown on the upper left corner of the display.
- (2) Press the open/close lever to open the transformer jaws and clamp them onto a single conductor and take the reading on the display. The most accurate reading will be obtained by keeping the conductor at the center of the transformer jaws.

## NOTE

- During current measurement, keep the transformer jaws fully closed. Otherwise, accurate measurements cannot be taken. Maximum conductor size is 55mm in diameter.
- Zero adjustment is not necessary in AC current measurement. There is no polarity in the reading either.
- When the current under test measures 3% of the full scale or less, or the frequency of the current is low, "LoHz" is indicated on the display.

## 2.4 DC Voltage Measurement

### WARNING

---

Never use the instrument on a circuit above 1000VDC. This may cause electrical shock hazard and damage to the instrument or the circuit under test. Keep your fingers and hands behind the barrier during measurement.

---

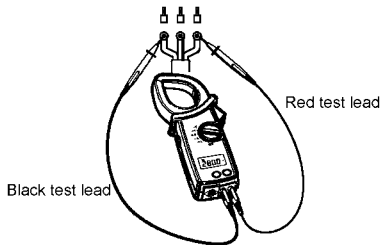

- (1) Set the Function Selector switch to the " $\text{DC V}$ " position. "DC" should be shown on the upper left corner of the display.
- (2) Slide the terminal cover to the left to disclose the Hi and Lo terminals. Plug the red test lead into the Hi terminal and the black test lead into Lo terminal.
- (3) Connect the tip of the red and black test leads to the positive (+) and negative (-) sides of the circuit under test respectively. Take the reading on the display.

## 2.5 AC Voltage Measurements

### WARNING

---

Never use the instrument on a circuit above 750VAC. This may cause electrical shock hazard and damage to the instrument or the circuit under test.

---

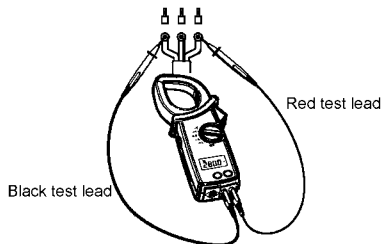

- (1) Set the Function Selector switch to the " $\sim V$ " position. "AC" should be shown on the upper left corner of the display.
- (2) Slide the terminal cover to the left to disclose the Hi and Lo terminals. Plug the red test lead into Hi terminal and the black test lead into the Lo terminal.
- (3) Connect the tip of the red and black test leads to the circuit under test and take the reading on the display.

### NOTE

When the voltage under test measures 3% of the full scale or less, or the frequency of the voltage is low, "LoHz" is indicated on the display.

## 2.6 Resistance Measurement



### WARNING

---

Never use the instrument on an energized circuit.

---

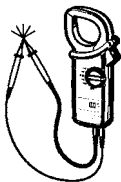

- (1) Set the Function Selector switch to the " $\Omega/\bullet$ " position. The " $\Omega$ " should be shown on the upper right corner of the display.
- (2) Slide the terminal cover to the left to disclose the Hi and Lo terminals. Plug the red test lead into the Hi terminal and the black test lead into the Lo terminal.
- (3) With the tip of the test leads shorted together, press the **AVG PEAK/Hz D/Hz** button to offset the resistance of the test leads.
- (4) Connect the tip of the test leads to the circuit under test and take the reading on the display.

## 2.7 Continuity Check (400 $\Omega$ range fixed)

The continuity check mode is enabled by pressing the **AVG PEAK/Hz D/Hz** button on resistance range. " $\bullet$ " and " $\Omega$ " is indicated on the display to show the instrument in the continuity check mode. The buzzer beeps, if the resistance under test is 20 $\Omega$  or less.



### WARNING

---

Never use the instrument on an energized circuit.

---

- (1) Set the Function Selector switch to the " $\Omega/\bullet$ " position.
- (2) Slide the terminal cover to the left to disclose the Hi and Lo terminals. Plug the red test lead into the Hi terminal and the black test lead into the Lo terminal.
- (3) With the tip of the test leads shorted together, press the **AVG PEAK/Hz D/Hz** button to offset the resistance of the test leads.

- (4) Press the  button once to enter from the normal mode to the continuity check mode. "•••)" should be indicated on the display.
- (5) Connect the tip of the test leads to the circuit under test. If the re-sistance is  $20\Omega$  or less, the buzzer beeps.

## 2.8 Frequency Measurement

- On ACA or ACV range, the frequency of the current or voltage under test can be counted and shown on the display.
- In the frequency measurement mode, "Hz" is indicated on the display.
- Trigger threshold is approx. 10V for AC voltage and approx. 10A for AC current. At frequency measurement, in case of low input signal, it often happens that measurement cannot be made. Because range is fixed at 400V for AC voltage and at 400A for AC current.



### WARNING

---

- Never use the instrument on a high voltage circuit above 750VAC. This may cause electrical shock hazard and damage to the instrument or the circuit under test.
  - Do not make current measurement with the test leads plugged into the instrument.
- 

- (1) Set the Function Selector switch to the " ~A " or " ~V " position.
- (2) Press the  button three times to enter from the normal mode to the frequency measurement mode. "Hz" should be indicated on the display.
- (3) Follow instructions for ACA or ACV measurement and take the frequency reading.

### NOTE

When the voltage under test measures 3% of the full scale or less, or the frequency of the current or voltage is 40Hz or less, "LoHz" is indicated on the display.

## 2.9 Peak Measurement

- In this mode, "**PEAK**" is indicated on the display.
- In the PEAK mode, the display shows current or voltage's crest in effective value. (For example, when the current or voltage is si-nusoidal, the reading equals the crest value divided by the square root of two.) The display reading is constantly updated with a maximum crest.
- Response time is 300ms in DC measurement and 10ms in AC measurement.





### WARNING

- Never use the instrument on a circuit above 750VAC or 1000VDC. This may cause electrical shock hazard and damage to the instrument or the circuit under test.
- Do not make measurement with the test leads plugged into the instrument.

- (1) The PEAK mode is available on DCA, ACA, DCV and DCA ranges. Set the Function Selector switch to the " $\overline{\sim}$ A", " $\sim$ A", " $\overline{\sim}$ V" or " $\sim$ V" position.

Note: Only on DCA range, press the  button for about one second to zero adjust the reading with the transformer jaws closed.

- (2) Press the  button twice to enter from the normal mode to the PEAK mode. "**PEAK**" should be shown on the display.
- (3) Follow instructions for DCA, ACA, DCV or ACV measurement.
- (4) For accurate reading, press the  button to reset the reading after clamping onto the conductor or making test lead connections to the circuit under test. Then proceed to measurement.

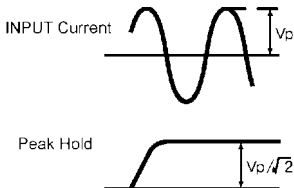





### NOTE

- In the PEAK mode, the auto-ranging feature is disabled and measuring ranges are fixed as follows.
  - DCA and ACA : 0 to 400.0A
  - DCA and ACV : 0 to 400.0V
- The Sleep function is disabled in the PEAK mode as well.

## 2.10 Average Measurement

This mode is available on ACV, DCV, ACA and DCA ranges.

- (1) Set the Function Selector switch to the "  A ", "  A ", "  V " or "  V " position.
- (2) Press the  button once to enter from the normal mode to the Average mode. " **AVG** " should be indicated on the display.
- (3) Follow instructions for ACV, DCV, ACA or DCA measurement.
- (4) The display shows a running average of six readings over an interval of about 2 seconds.



## 3. Other Functions

### 3.1 Sleep Function

This is a function to prevent the instrument from being left powered on in order to conserve battery life. This function causes the instrument to enter the Sleep (powered-down) mode about 30 minutes after the last switch or button operation.

To exit the Sleep mode, turn the Function Selector switch back to "OFF", then to any other position, or press any button.

The current is consumed a little in the Sleep mode.

#### NOTE

- Connecting the plug to the OUTPUT terminal disables the Sleep function. The function is enabled on removing the plug from the terminal.
- The Sleep function is disabled in the PEAK measurement mode.

### 3.2 Data Hold Function

This is a function used to freeze the measured value on the display. Press the Data Hold button to freeze the reading. The reading will be held regardless of subsequent variation in input. "H" is shown on the upper right corner of the display while the instrument is in the Data Hold mode.

To exit the Data Hold mode, press the Data Hold button again.

#### NOTE

If the instrument in the Data Hold mode goes into "sleep", it will return to the normal mode.

### 3.3 LoHz Function

In ACV or ACA range, if frequency of the voltage or current under test is 40Hz or lower, the display indicates "LoHz" and sample rate is automatically switched from the normal 3 times/sec to 2 times/sec to reduce fluctuation of the reading. "LoHz" is also indicated where input is 3% of full scale or less.

### 3.4 OUTPUT Terminal (For current ranges only)

#### WARNING

- Never use the instrument on a circuit above 750VAC or 1000VDC. This may cause electrical shock hazard and damage to the instrument or the circuit under test.
- Never apply voltage to the OUTPUT terminal.

When the plug is inserted into the output terminal, auto-range function is cleared.

Set the range depending on the state of Data Hold Switch.

Data Hold Switch OFF	400A range
Data Hold Switch ON	2000A range

#### NOTE

After measurement, be sure to return Data Hold switch to "OFF" position.

- (1) Attach the output plug cable (sold separately : 98076 or 98077) to a connection lead so that the output voltage can be connected to a recording device such as a chart recorder.
- (2) Slide the terminal cover to the right to disclose the OUTPUT terminal and insert the output plug into the terminal. Make connection to the recording device.

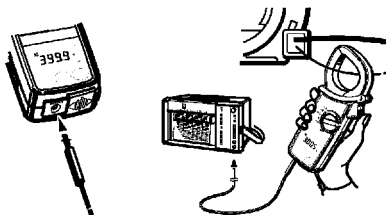

- (3) Set the Function Selector switch to the desired position (ACA or DCA) and follow appropriate measurement instructions.

## NOTE

- Consult the output voltage specifications shown in chapter 5 and adjust the sensitivity of the recording device.
- On DC current range, the **0 A ZERO RESET** button may not completely zero adjust the output voltage from the OUTPUT terminal. In this case, make zero adjustment on the recording device.
- Connecting the plug to the OUTPUT terminal disables the Sleep function. The function is enabled on removing the plug from the terminal. The in-strument enters Sleep mode 30 minutes after the plug is removed.
- For long hours of use of the OUTPUT terminal, use an Alkaline battery, which will extend continuous recording time up to about 24 hours.

## 3.5 Optional Accessories

Clamp Adapter Model 99025 (For AC current measurement only)

The clamp adapter (99025) has been discontinued.

The clamp adapter (99025) is designed to increase the measuring capability of a clamp meter. With the use of the Clamp Adapter, you can not only extend current range over 3000A, but also clamp on a large bus-bar or con-ductor.

- (1) Set the Function Selector switch to the "  $\sim$ A " position.
- (2) As shown in the figure below, clamp Model CL255 onto the pickup coil of Model 99025.
- (3) Clamp Model 99025 onto the bus-bar or conductor under test.
- (4) Take the reading on Model CL255 and multiply it by 10.

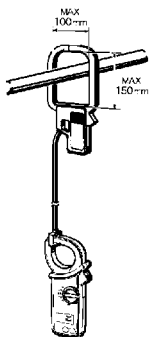

## 4. Battery Replacement

### WARNING

---

To avoid electric shock hazard, make sure to set the Function Selector switch to "OFF" and remove the test leads from the instrument before trying to replace battery.

---

### CAUTION

---

Make sure to install battery in correct polarity as indicated in battery compartment.

---

If the battery voltage becomes too low for the instrument to operate normally, "**BATT**" is shown on the display. Then, replace the battery. Note that when the battery is completely exhausted, the display blanks without "**BATT**" shown.

- (1) Set the Function Selector switch to the "OFF" position.
- (2) Unscrew and remove the battery compartment on the bottom of the instrument.
- (3) Replace the battery observing correct polarity. Use a new 6LR61 (Alkaline) or 6F22 (Manganese) 9V battery.
- (4) Re-place and screw the battery compartment cover.

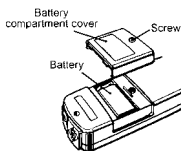

## 5. Specifications

### ■ Instrument Specifications

- Measuring Ranges and Accuracy (at  $23\pm 5^{\circ}\text{C}$ , 45 to 75% relative humidity)

DC Current  $\text{---}\text{A}$

Measuring Range (Auto-ranging)	Accuracy
0 to $\pm 399.9\text{A}$	$\pm 1.5\% \text{ rdg} \pm 2\text{dgt}$
$\pm 150$ to $\pm 2000\text{A}$	

Auto-ranging

Lo : 0 to 399.9A (Shifts to Hi at 400.0A)

Hi : 150 to 2000A (Shifts to Lo at 149A. At 2020A or above, "OL" is shown.)

AC Current  $\sim\text{A}$  (Crest factor (CF): 3.0 or less, peak current: 3000A or less)

Measuring Range (Auto-ranging)	Accuracy
5.0 to $\pm 399.9\text{A}$	$\pm 1.5\% \text{ rdg} \pm 3\text{dgt}$ (50/60Hz)
150 to 1700A	$\pm 3.0\% \text{ rdg} \pm 4\text{dgt}$ (30 to 1kHz)
1701 to 2000A	$\pm 3.5\% \text{ rdg} \pm 3\text{dgt}$ (50/60Hz)

Conversion method : AC coupled, true rms responding, calibrated to the rms

Auto-ranging

Lo : 0 to 399.9A (Shifts to Hi at 400.0A)

Hi : 150 to 2000A (Shifts to Lo at 149A. At 2020A or above, "OL" is shown.)

DC Voltage  $\text{---}\text{V}$  (Input impedance:  $2\text{M}\Omega$ )

Measuring Range (Auto-ranging)	Accuracy
0 to $\pm 39.99\text{V}$	$\pm 1.0\% \text{ rdg} \pm 2\text{dgt}$
$\pm 15.0$ to $\pm 399.9\text{V}$	
$\pm 150$ to $\pm 1000\text{V}$	

Auto-ranging

Lo : 0 to 39.99V (Shifts to Mid at 40.00V)

Mid : 15.0 to 399.9V (Shifts to Lo at 14.9V and to Hi at 400.0V)

Hi : 150 to 1000V (Shifts to Mid at 149V. At 1020V or above, "OL" is shown.)

AC Voltage  $\sim V$  (Input impedance: 1M $\Omega$ )

(Crest factor (CF): 3.0 or less, peak voltage: 1200V or less)

Measuring Range (Auto-ranging)	Accuracy
0.50 to 39.99V	$\pm 1.5\%$ rdg $\pm 3$ dgt (50/60Hz) $\pm 2.0\%$ rdg $\pm 4$ dgt (30 ~ 1kHz)
15.0 to 399.9V	
150 to 750V	

Conversion method : AC coupled, true rms responding, calibrated to the rms  
Auto-ranging

Lo : 0 to 39.99V (Shifts to Mid at 40.00V)

Mid : 15.0 to 399.9V (Shifts to Lo at 14.9V and to Hi at 400.0V)

Hi : 150 to 750V (Shifts to Mid at 149V. At 770V or above, "OL" is shown.)

Resistance  $\Omega$

Measuring Range (Auto-ranging)	Accuracy
0 to 399.9 $\Omega$	$\pm 1.5\%$ rdg $\pm 2$ dgt
150 to 3999 $\Omega$	

Auto-ranging

Lo : 0 to 399.9 $\Omega$  (Shifts to Hi at 400.0 $\Omega$ )

Hi : 150 to 3999 $\Omega$  (Shifts to Lo at 149 $\Omega$ . At 4000 $\Omega$  or above, "OL" is shown.)

Continuity Check  $\Omega/\bullet$  (Range fixed)

Measuring Range	Accuracy
10 to 399.9 $\Omega$	$\pm 1.5\%$ rdg $\pm 2$ dgt

The buzzer beeps when the resistance is 20 $\Omega$  or less.

Frequency

Measuring Range	Accuracy
10 to 3999Hz	$\pm 1.5\%$ rdg $\pm 5$ dgt



OUTPUT (Output impedance: about 10k $\Omega$ )

	Measuring Range	Output voltage (mVDC)	Accuracy
DC	0 to $\pm 399.9$ A	0 to $\pm 399.9$ mV	$\pm 1.5\%$ rdg $\pm 3$ mV
	$\pm 150$ to $\pm 2000$ A	$\pm 15.0$ to $\pm 200.0$ mV	
AC	0 to 399.9A	0 to 399.9mV	$\pm 1.5\%$ rdg $\pm 3$ mV(50/60Hz)
	150 to 1700A	15.0 to 170.0mV	$\pm 3.0\%$ rdg $\pm 3$ mV(40 ~ 1kHz)
	1701 to 2000A	170.1 to 200.0mV	$\pm 3.5\%$ rdg $\pm 3$ mV (50/60Hz)

### \*Effective Value (rms)

Most alternating currents and voltages are expressed in effective values, which are also referred to as RMS (Root-Mean-Square) values. The effective value is the square root of the average of square of alternating current or voltage values.

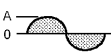
Many clamp meters using a conventional rectifying circuit have "RMS" scales for AC measurement. The scales are, however, actually calibrated in terms of the effective value of a sine wave though the clamp meter is responding to the average value. The calibration is done with a conversion factor of 1.111 for sine wave, which is found by dividing the effective value by the average value. These instruments are therefore in error if the input voltage or current has some other shape than sine wave.

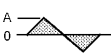
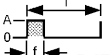
Waveform	Effective value V rms	Average value V avg	Conversion factor V rms/V avg	Reading errors for average sensing instruments	Crest factor CF
	$\frac{1}{\sqrt{2}} A$ $\approx 0.707$	$\frac{2}{\pi} A$ $\approx 0.637$	$\frac{\pi}{2\sqrt{2}}$ $\approx 1.111$	0%	$\sqrt{2}$ $\approx 1.414$
	A	A	1	$\frac{A \times 1.111 - A}{A} \times 100$ $\approx 11.1\%$	1
	$\frac{1}{\sqrt{3}} A$	0.5A	$\frac{2}{\sqrt{3}}$ $\approx 1.155$	$\frac{0.5A \times 1.111 - \frac{A}{\sqrt{3}}}{\frac{A}{\sqrt{3}}} \times 100$ $= -3.8\%$	$\sqrt{3}$ $\approx 1.732$
	$A\sqrt{D}$	$A \frac{f}{T}$ $= A \cdot D$	$\frac{A\sqrt{D}}{AD} = \frac{1}{\sqrt{D}}$	$(1.111\sqrt{D} - 1) \times 100\%$	$\frac{A}{A\sqrt{D}} = \frac{1}{\sqrt{D}}$

\*CF(Crest Factor) is found by dividing the peak value by the effective value.

Examples:

DC: CF=1

Sine wave: CF=1.414

Square wave with a 1:10 duty ratio: CF=3

## ■ General Specifications

- Operating System :  $\Delta\Sigma$  modulation
- Measurement Function : AC current, DC current, AC voltage, DC voltage, resistance, continuity check, frequency
- Display : Liquid crystal display with maximum counts of 3999

- Overrange Indication : "OL" is shown on the display
- Response Time : Approx. 2 seconds.
- Sample Rate : Approx. 3 times per second.
- Temperature and Humidity for Guaranteed Accuracy : 23°C ±5°C , relative humidity up to 75% without condensation
- Operating Temperature and Humidity : 0 to 40°C , relative humidity up to 85% without condensation
- Storage Temperature and Humidity : -20 to 60°C , relative humidity up to 85% without condensation
- Effect of conductor position : Within ±1.5%rdg ±3dgt of indicated value at the center to a 10 mm-dia conductor carrying 100A, at every part inside the jaws
- Effect of external magnetic field : 4A or less in AC or DC magnetic field of 400 A/m
- Power Source : 6LR61 or 6F22 9V battery
- Battery Life : Approx. 15 hours (continuity)
- Current Consumption : Approx. 15mA max.
- Sleep function : Automatically powered down in Approx. 30 minutes after the last switch operation (power consumption : Approx. 200 μA)
- Withstanding Voltage : 6300V AC, 50/60Hz for 5sec. between electrical circuit and housing case or metal part of the jaws
- Insulation Resistance : 10MΩ or greater at 1000V between electrical circuit and housing case or metal part of the jaws
- Conductor Size : Approx. 55mm diameter max.
- Dimensions : Approx. 105(W) x 250(H) x 49(D) mm
- Weight : Approx. 540g (with battery)
- Safety Standard: EN 61010-1, EN 61010-2-033  
EN 61010-031, EN 61010-2-032  
AC/DC 600V CAT III, AC/DC 1000V CAT II,  
Pollution degree 2, indoor use, altitude 2000m or less
- EMC Standard: EN 61326-1, EN 61326-2-1
- Radiation immunity : EN 61000-4-3
- Environmental standard: EN 50581
- Accessories :
 

Test leads Model 98072	1set
6F22 battery	1
Carrying case Model 93034	1
User's Manual	1
- Optional Accessories : Output cable Model 98076  
Output cable (for terminal screw) Model 98077



## 6. Calibration and After-sales Service

Should any failure occur while you are using the tester, follow the instructions given below. If the tester still fails to operate correctly and needs repair, contact the vendor from whom you purchased the instrument or the nearest Yokogawa Meters & Instruments sales office.

- Turn off the POWER switch once, then turn it back on again.
- If the tester does not turn on, replace the battery with a new one.

### Calibration

It is recommended that the instrument be calibrated once every year.

### Waste Electrical and Electronic Equipment (WEEE), Directive

(This directive is valid only in the EU.)

This product complies with the WEEE directive marking requirement.

This marking indicates that you must not discard this electrical/electronic product in domestic household waste.

#### Product Category

With reference to the equipment types in the WEEE directive, this product is classified as a "Monitoring and control instruments" product.

When disposing products in the EU, contact your local Yokogawa Europe B.V. office.

Do not dispose in domestic household waste.



This User's Manual explains the Prevention of Pollution Control of Electronic Equipmen Method in China. This manual is valid only in China.

### 产品中有害物质的名称及含量

部件名称	有害物质					
	铅 (Pb)	汞 (Hg)	镉 (Cd)	六价铬 (Cr (VI))	多溴联苯 (PBB)	多溴二苯醚 (PBDE)
框架 (塑料)	○	○	○	○	○	○
线路板 ASSY	×	○	×	○	○	○
导线	×	○	○	○	○	○
电池	×	○	○	○	○	○

- ：表示该有害物质在该部件所有均质材料中的含量均在GB/T 26572规定的限量要求以下。
- ×：表示该有害物质至少在该部件的某一均质材料中的含量超出GB/T 26572规定的限量要求。

环保使用期限：



该标识适用于 SJ/T11364 中所述，在中华人民共和国销售的电子电气产品的环保使用期限。只要您遵守该产品相关的安全及使用注意事项，在自制造日起算的年限内，则不会因产品中有有害物质泄漏或突发变异，而造成对环境的污染或对人体及财产产生恶劣影响。

