**User's
Manual**



**Model PR300
Power and Energy Meter
Communication Interface
(RS-485 and Ethernet Communications)**

IM 77C01E01-10E

vigilantplant.®

Introduction

This user's manual describes the communication functions of the PR300 power and energy meter and contains information on how to create communication programs.

Hereafter, the PR300 power and energy meter is simply referred to as the PR300.

Read the manual carefully to understand the communication functions of the PR300 .

The PR300 has the following communication protocols.

- PC link communication protocol
- Modbus /RTU and Modbus/ASCII communication protocols
- Modbus/TCP communication protocol (for the PR300 with Ethernet communication function)
- PR201 original communication protocol

You are required to have background knowledge of the communication specifications of higher-level devices, their communication hardware, language used for creating communication programs, and so on.

■ Intended Readers

This manual is intended for people familiar with the functions of the PR300, control engineers and personnel in charge of maintaining instrumentation and control equipment.

■ Related Documents

The following user's manuals all relate to the communication functions of the PR300. Read them as necessary.

- Model PR300 Power and Energy Meter User's Manual (electronic manual)
Document number: IM 77C01E01-01E
- Model PR300 Power and Energy Meter Startup Manual <Installation>
Document number: IM 77C01E01-02E
- Model PR300 Power and Energy Meter Startup Manual <Initial Setup Operations>
Document number: IM 77C01E01-03E

These manuals provide information about the procedure of installation, wiring and operation.

■ Trademark

- (1) All the brands or names of Yokogawa Electric's products used in this manual are either trademarks or registered trademarks of Yokogawa Electric Corporation.
- (2) Ethernet is a registered trademark of XEROX Corporation in the United States.
- (3) Company and product names that appear in this manual are trademarks or registered trademarks of their respective holders.

Documentation Conventions

■ Symbols

This manual uses the following symbols.

● Symbols Used in the Main Text



NOTE

Draws attention to information that is essential for understanding the operation and/or features of the product.

TIP

Gives additional information to complement the present topic.

See Also

Gives reference locations for further information on the topic.

● Symbols Used in Figures and Tables

[NOTE]

Draws attention to information that is essential for understanding the features of the product.

[TIP]

Gives additional information to complement the present topic.

[See Also]

Gives reference locations for further information on the topic.

■ Description of Displays

- (1) Some of the representations of product displays shown in this manual may be exaggerated, simplified, or partially omitted for reasons of convenience when explaining them.
- (2) Figures and illustrations representing the PR300's displays may differ from the real displays in regard to the position and/or indicated characters (upper-case or lower-case, for example), the extent of difference does not impair a correct understanding of the functions and the proper operations and monitoring of the system.

Notices

■ Regarding This User's Manual

- (1) This manual should be passed on to the end user. Keep the manual in a safe place.
- (2) Read this manual carefully to gain a thorough understanding of how to operate this product before you start using it.
- (3) This manual is intended to describe the functions of this product. Yokogawa Electric Corporation (hereinafter simply referred to as Yokogawa) does not guarantee that these functions are suited to the particular purpose of the user.
- (4) Under absolutely no circumstance may the contents of this manual, in part or in whole, be transcribed or copied without permission.
- (5) The contents of this manual are subject to change without prior notice.
- (6) Every effort has been made to ensure accuracy in the preparation of this manual. Should any errors or omissions come to your attention however, please contact your nearest Yokogawa representative or our sales office.
- (7) The document concerning TCP/IP software has been created by Yokogawa based on the BSD Networking Software, Release 1 that has been licensed from the University of California.

■ Regarding Protection, Safety, and Prohibition Against Unauthorized Modification

- (1) In order to protect the product and the system controlled by it against damage and ensure its safe use, be certain to strictly adhere to all of the instructions and precautions relating to safety contained in this document. Yokogawa does not guarantee safety if products are not handled according to these instructions.
- (2) The following safety symbols are used on the product and/or in this manual.

● Symbols Used on the Product and in This Manual



This symbol on the product indicates that the operator must refer to an explanation in the user's manual in order to avoid the risk of injury or death of personnel or damage to the instrument. The manual describes how the operator should exercise special care to avoid electric shock or other dangers that may result in injury or loss of life.



Protective Grounding Terminal

This symbol indicates that the terminal must be connected to ground prior to operating the equipment.

■ Force Majeure

- (1) Yokogawa does not make any warranties regarding the product except those mentioned in the WARRANTY that is provided separately.
- (2) Yokogawa assumes no liability to any party for any loss or damage, direct or indirect, caused by the use or any unpredictable defect of the product.
- (3) Be sure to use the spare parts approved by Yokogawa when replacing parts or consumables.
- (4) Modification of the product is strictly prohibited.
- (5) Reverse engineering such as the disassembly or decompilation of software is strictly prohibited.
- (6) No portion of the software supplied by Yokogawa may be transferred, exchanged, leased, or sublet for use by any third party without the prior permission of Yokogawa.

Model PR300 Power and Energy Meter Communication Interface (RS-485 and Ethernet Communications)

IM 77C01E01-10E 4th Edition

CONTENTS

- Introduction i
- Documentation Conventions ii
- Notices iii
- 1. Communications Overview**
 - 1.1 RS-485 Communication Specifications 1-1
 - 1.2 Ethernet Communication Specifications 1-1
- 2. Setup**
 - 2.1 Setup Procedure 2-1
 - 2.1.1 Procedure for RS-485 Communication 2-2
 - 2.1.2 Procedure for Ethernet Communication 2-3
 - 2.1.3 Procedure for Ethernet-Serial Gateway Function 2-4
 - 2.2 Setting Communication Conditions 2-6
 - 2.2.1 Conditions for RS-485 Communication 2-6
 - 2.2.2 Conditions for Ethernet Communication 2-8
 - 2.2.3 Conditions for Ethernet-Serial Gateway Function 2-10
 - 2.3 Wiring for Communication 2-12
 - 2.3.1 Wiring for RS-485 Communication 2-12
 - 2.3.2 Wiring for Ethernet Communication 2-13
 - 2.3.3 Wiring for RS-485 Communication for Ethernet-Serial Gateway Function .. 2-14
- 3. Procedures for Setting PR300 Functions**
 - 3.1 Basic Setting 3-2
 - 3.1.1 Setting of VT Ratio 3-2
 - 3.1.2 Setting of CT Ratio 3-3
 - 3.1.3 Setting of Integrated Low-cut Power 3-4
 - 3.2 Setting Pulse Output 3-5
 - 3.2.1 Selection of Measurement Item for Pulse Output 3-5
 - 3.2.2 Pulse Unit 3-6
 - 3.2.3 ON Pulse Width 3-7
 - 3.3 Setting Analog Output 3-8
 - 3.3.1 Selection of Measurement Item for Analog Output 3-8
 - 3.3.2 Upper/Lower Limits of Scaling 3-9
 - 3.4 Demand Setting 3-10
 - 3.4.1 Demand Power/Current 3-10
 - 3.4.2 Demand Period 3-11
 - 3.4.3 Demand Alarm Mask Time 3-12
 - 3.4.4 Demand Power Alarm Point 3-13

3.4.5	Demand Current Alarm Point	3-14
3.4.6	Demand Alarm Release Function	3-15
3.5	Communication Setting	3-16
3.5.1	Protocol	3-16
3.5.2	Baud Rate	3-17
3.5.3	Parity	3-18
3.5.4	Stop Bit	3-19
3.5.5	Data Length	3-20
3.5.6	Station Number	3-21
3.5.7	IP Address (for Ethernet communication)	3-22
3.5.8	Subnet Mask (for Ethernet communication)	3-23
3.5.9	Default Gateway (for Ethernet communication)	3-24
3.5.10	Port Number (for Ethernet communication)	3-25
3.6	Writing Energy Values	3-26
3.6.1	Active Energy	3-26
3.6.2	Regenerative Energy	3-27
3.6.3	LEAD Reactive Energy	3-28
3.6.4	LAG Reactive Energy	3-29
3.6.5	Apparent Energy	3-30
3.7	Executing Reset Operations	3-31
3.7.1	Remote Reset	3-31
3.7.2	Maximum/Minimum Values Reset	3-32
3.7.3	Energy Value All-Reset	3-32
3.7.4	Active Energy Reset	3-33
3.7.5	Regenerative Energy Reset	3-33
3.7.6	Reactive Energy Reset	3-34
3.7.7	Apparent Energy Reset	3-34
3.8	Setting Control States	3-35
3.8.1	Integration Start/Stop	3-35
3.8.2	Optional Integration Start/Stop	3-36
3.8.3	Demand Measurement Start/Stop	3-37
3.8.4	Confirmation and Release of Demand Alarm State	3-38
4.	PC Link Communication Protocol	
4.1	Overview	4-1
4.1.1	Configuration of Command	4-2
4.1.2	Configuration of Response	4-3
4.1.3	Response Error Codes	4-4
4.1.4	Specifying Broadcast	4-5
4.2	Command and Response	4-6
WRD	Reads D registers on a word-by-word basis	4-7
WWR	Writes data into D registers on a word-by-word basis	4-8
WRR	Reads D registers on a word-by-word basis in random order	4-9
WRW	Writes data into D registers on a word-by-word basis in random order ...	4-10
WRS	Specifies the D registers to be monitored on a word-by-word basis	4-11
WRM	Monitors the D registers on a word-by-word basis	4-12
INF6	Reads the model, suffix codes, and version information	4-13
INF7	Reads the maximum value of CPU	4-14
4.3	Communication with Higher-level Devices	4-15
4.3.1	Communication with FA-M3 (UT Link Module)	4-15

4.4	Sample Program	4-17
4.4.1	Example of BASIC Program for Send and Receive	4-17
5.	Modbus/RTU and ASCII Communication Protocols	
5.1	Overview	5-1
5.1.1	Configuration of Message	5-3
5.1.2	Specifying D Registers	5-4
5.1.3	Checking Errors	5-4
5.1.4	Configuration of Response	5-7
5.1.5	Specifying Broadcast	5-9
5.2	Message and Response	5-10
03	Reads data from multiple D registers	5-11
06	Writes data into D register	5-12
08	Performs loop back test	5-13
16	Writes data into multiple D registers	5-14
6.	Modbus/TCP Communication Protocol	
6.1	Overview	6-1
6.2	TCP/IP Communication	6-3
6.3	Network Frame Structure	6-4
6.3.1	MBAP Header Structure	6-4
6.3.2	PDU Structure	6-4
6.4	Communication with Higher-level Devices	6-5
6.4.1	List of Function Codes	6-5
6.4.2	Specifying D Registers	6-5
6.4.3	Request and Response	6-6
03	Reads data from multiple D registers	6-6
06	Writes data into D register	6-7
08	Performs loop back test	6-8
16	Writes data into multiple D registers	6-9
6.4.4	Response Error Codes	6-11
6.5	Sample Program	6-12
6.5.1	Example of BASIC Program for Send and Receive	6-12
7.	Functions and Usage of D Registers	
7.1	Overview of D Registers	7-1
7.2	Configuration of D Registers	7-1
7.3	Interpretation of D Register Map Table	7-1
7.4	D Register Map	7-2
8.	PR201 Original Communication Protocol	
8.1	Overview	8-1
8.2	Communication Specifications	8-1
8.3	Command/Response Format	8-2
8.4	List of Commands	8-3
8.5	Command Details	8-5
Appendix	Table of ASCII Codes (Alphanumeric Codes)	
	Revision Information	

1. Communications Overview

1.1 RS-485 Communication Specifications

Protocols available for RS-485 communication interfaces include the PC link communication protocol and the Modbus communication protocol.

Table 1.1 RS-485 Communication Specifications

Item	Details	Connected Device
Communication Hardware	2-wire system RS-485	—
Compliant Standard	EIA RS-485	—
Protocol Specification	PC Link Communication with and without checksum	A PC installed with a driver for PC link communication and SCADA software, PLC (FA-M3 UT link module), etc.
	Modbus Communication (ASCII and RTU modes)	A PC installed with a Modbus driver and SCADA software, a Modbus-compatible PLC, etc.
	PR201 original communication	Personal computer etc. with SCADA software installed to support PR201 original communication protocol
Baud Rate	2400 bps, 9600 bps, 19200 bps	—
Maximum Communication Distance	1200 m	
Maximum Number of Connectable Devices	31	
Transmission Method	2-wire, half-duplex	
Synchronization	Start-stop synchronization	
Communication Method	Non-procedural	
Communication Cable	Shielded twisted pair cable (AWG24-equivalent size)	

1.2 Ethernet Communication Specifications

Protocols available for Ethernet communication interfaces include the Modbus/TCP communication protocol.

Table 1.2 Ethernet Communication Specifications

Item	Details	Connected Device
Communication Hardware	10BASE-T/100BASE-TX	—
Compliant Standard	Ethernet IEEE802.3	
Access Control	CSMA/CD	
Protocol Specification	Modbus communication (Port No.: 502)	Ethernet-equipped PC etc.
Baud Rate	10 Mbps/100 Mbps	—
Maximum Segment Length	100 m *1	
Maximum Connecting Configuration	Cascade max. 4 levels (for 10BASE-T) max. 2 levels (for 100BASE-TX) *2	
Communication System	TCP/IP	
Data Format	Binary	
Maximum Number of Connections	1	

*1: Distance between the hub and module.

*2: The number of hubs connectable in cascade configuration.

2. Setup

This chapter describes how to set up the PR300, which is equipped with RS-485 communication as a standard feature.

When using an Ethernet-equipped model, either RS-485 or Ethernet can be selected by parameter setting for communications.

For details of use of RS-485 communication, see subsection 2.1.1 “Procedure for RS-485 Communication.”

For details of use of the Ethernet communication, see subsection 2.1.2 “Procedure for Ethernet Communication.”

For details of use of the Ethernet-serial gateway function, see subsection 2.1.3 “Procedure for Ethernet-Serial Gateway Function.”

2.1 Setup Procedure

Set up the communication functions on the PR300 as follows:



WARNING

To avoid an electric shock, be sure to turn off the power supply source to the equipment involved before you start wiring.

Note: Create communication programs referring to the user’s manual for communications of each higher-level device.
Higher-level devices : PCs, PLCs (sequencers), and others.

2.1.1 Procedure for RS-485 Communication

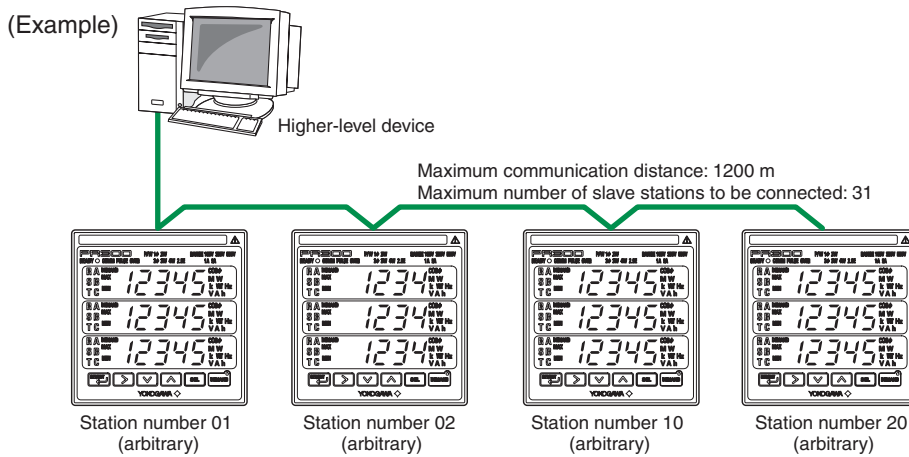

1 Communication parameters setting for PR300

Set up the communication function using the front panel keys.

See

Subsection 2.2.1 “Conditions for RS-485 Communication”

2 Connect a higher-level device with PR300

See

Subsection 2.3.1 “Wiring for RS-485 Communication”

3 Create communication programs for the higher-level device to perform communication

See

Chapter 3
“Procedures for Setting PR300 Functions”

For communication protocol, see

Chapter 4
“PC Link Communication Protocol”

Chapter 5
“Modbus/RTU and ASCII Communication Protocols”

Chapter 8
“PR201 Original Communication Protocol”

For data storage location, see

Chapter 7
“Functions and Usage of D Registers”

2.1.2 Procedure for Ethernet Communication

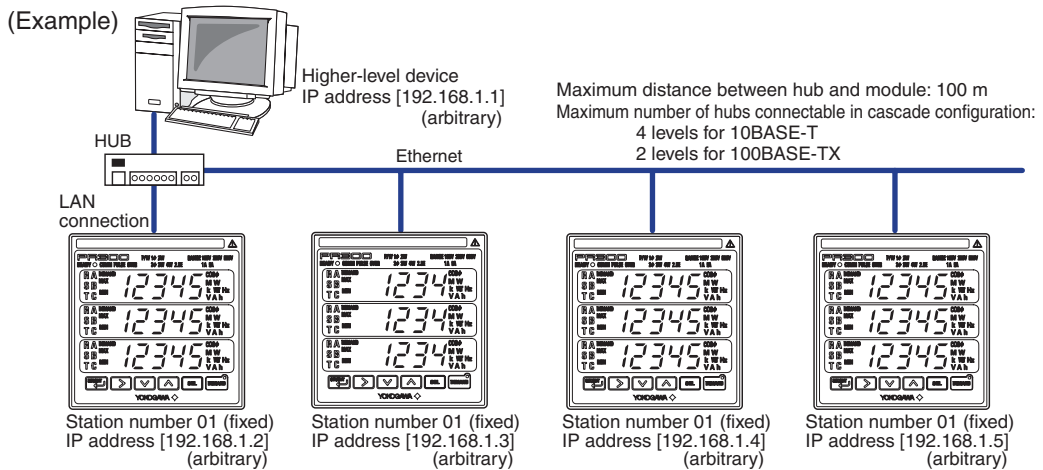

1

Communication parameters setting for PR300

Set up the communication function using the front panel keys.

See

Subsection 2.2.2 "Conditions for Ethernet Communication"

2

Connect a higher-level device with PR300

See

Subsection 2.3.2 "Wiring for Ethernet Communication"

3

Create communication programs for the higher-level device to perform communication

See

Chapter 3
"Procedures for Setting PR300 Functions"

For communication protocol, see
Chapter 6
"Modbus/TCP Communication Protocol"

For data storage location, see
Chapter 7
"Functions and Usage of D Registers"

Note: It is recommended to use the Ethernet network as a dedicated one for the PR300.

2.1.3 Procedure for Ethernet-Serial Gateway Function

(Example)

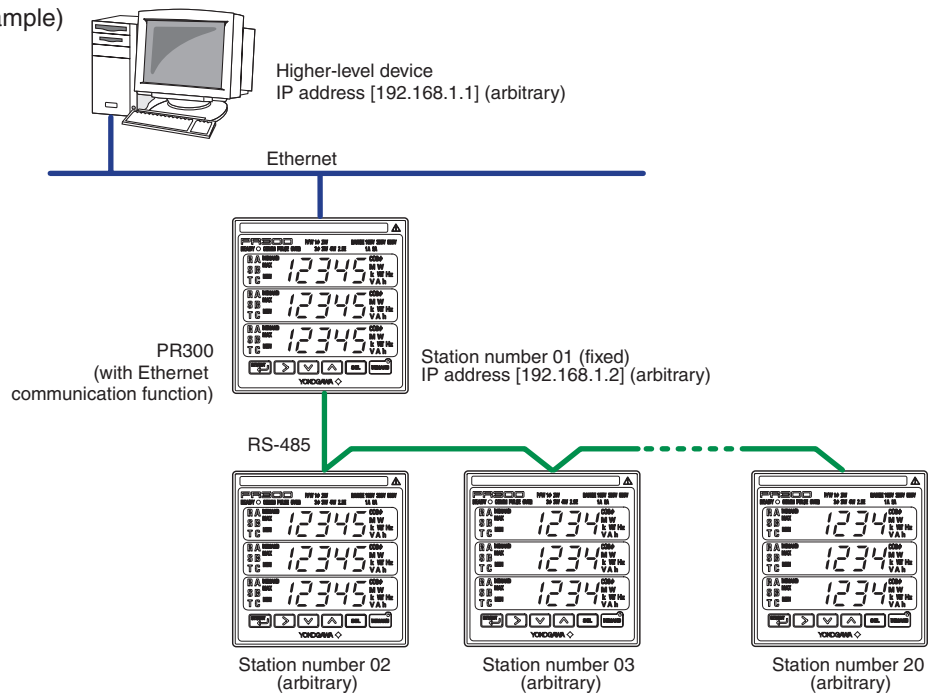

- 1** **Communication parameters setting for PR300**
Set up the communication function using the front panel keys.

See

 - Subsection 2.2.2
“Conditions for Ethernet Communication”
 - Subsection 2.2.3
“Conditions for Ethernet-Serial Gateway Function”

- 2** **Connect a higher-level device with PR300**

See

 - Subsection 2.3.2
“Wiring for Ethernet Communication”

- 3** **Connect a lower-level device with PR300**

See

 - Subsection 2.3.3
“Wiring for RS-485 Communication for Ethernet-Serial Gateway Function”

- 4** **Create communication programs for the higher-level device to perform communication**

See

 - Chapter 3
“Procedures for Setting PR300 Functions”
 - For communication protocol, see
Chapter 6
“Modbus/TCP Communication Protocol”
 - For data storage location, see
Chapter 7
“Functions and Usage of D Registers”

Note: It is recommended to use the Ethernet network as a dedicated one for the PR300.

● VJET Ethernet/RS-485 converter as an Ethernet-serial gateway function

(Example)

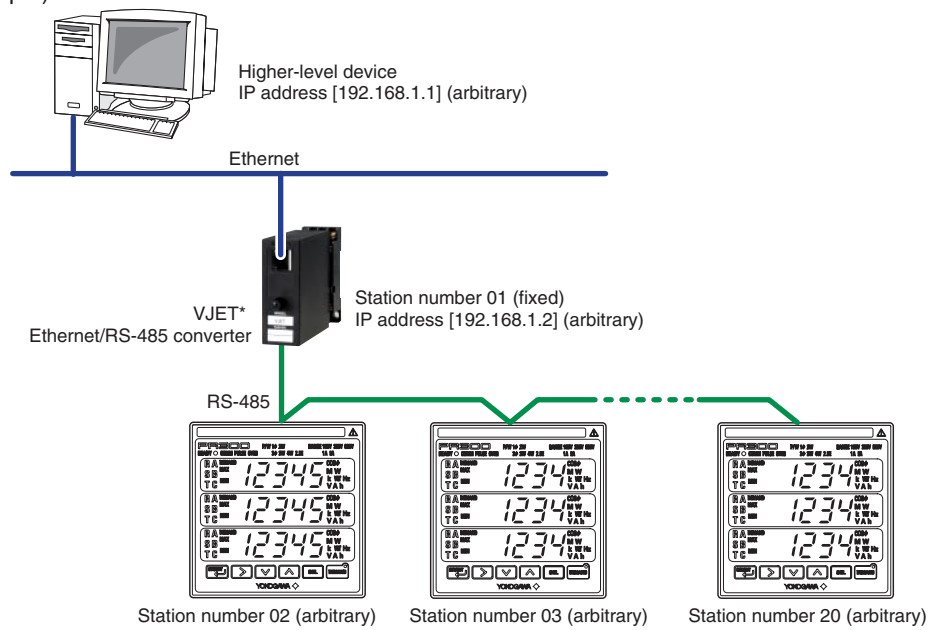

* The VJET is Yokogawa's converter. For details of use of the VJET, refer to its user's manual.

Note: It is recommended to use the Ethernet network as a dedicated one for the PR300.
The communication conditions of any slave PR300 must conform to those of the VJET at a higher level.

2.2 Setting Communication Conditions

This section describes the setting parameters for using the communication functions, and the setting ranges. For details of setting method, refer to the PR300 Power and Energy Meter User's Manual (electronic manual).

2.2.1 Conditions for RS-485 Communication

This subsection describes the setting parameters for using the RS-485 communication function, and the setting ranges.

Table 2.1 Parameters to be Set for Communication Functions

Parameter Name	Menu	Parameter Symbol	Setting Range	Initial Value	
Station number		<i>St-no</i> (ST-NO)	01 to 99 (01 to 31 recommended)	01	
Protocol		<i>Comm</i> (COMM)	PC link without checksum	<i>PCLK1</i> (PCLK1)	PCLK2
			PC link with checksum	<i>PCLK2</i> (PCLK2)	
			Modbus/ASCII	<i>M ASC</i> (M ASC)	
			Modbus/RTU	<i>M RTU</i> (M RTU)	
			Modbus/TCP*1	<i>M TCP</i> (M TCP)	
			PR201 original	<i>PR201</i> (PR201)	
Baud rate	<i>r-485</i> (RS-485 communication)	<i>b-rt</i> (B-RT)	2400 bps 9600 bps 19200 bps	9600	
Parity*3		<i>Par</i> (PRI)	None Even Odd	<i>none</i> (NONE) <i>EVEN</i> (EVEN) <i>odd</i> (ODD)	NONE
Stop bit*3		<i>STP</i> (STP)	1 2	1	
Data length*2 *3		<i>DLN</i> (DLN)	7 8	8	

*1: Modbus/TCP can be selected for the PR300 with Ethernet communication function only.

*2: When Modbus /RTU is selected for the protocol, select 8 for the data length. If 7 is selected for the data length, communication is not possible.

*3: When PR201 original is selected for the protocol, select NONE for the parity, 1 for the stop bit and 8 for the data length.

● **Protocol (COMM)**

Set the communication protocol identical to that of the higher-level device to be connected.

● **Station number (ST-NO)**

Set the station number of the PR300 itself. A station number of 01 to 99 may be assigned in any order. However, the maximum number of PR300 to be connected to a single communication port is 31.

When connecting two or more PR300 to a single communication port, set a different station number to each.

Example of connecting a higher-level device with four PR300 having station numbers 01, 05, 10, and 20

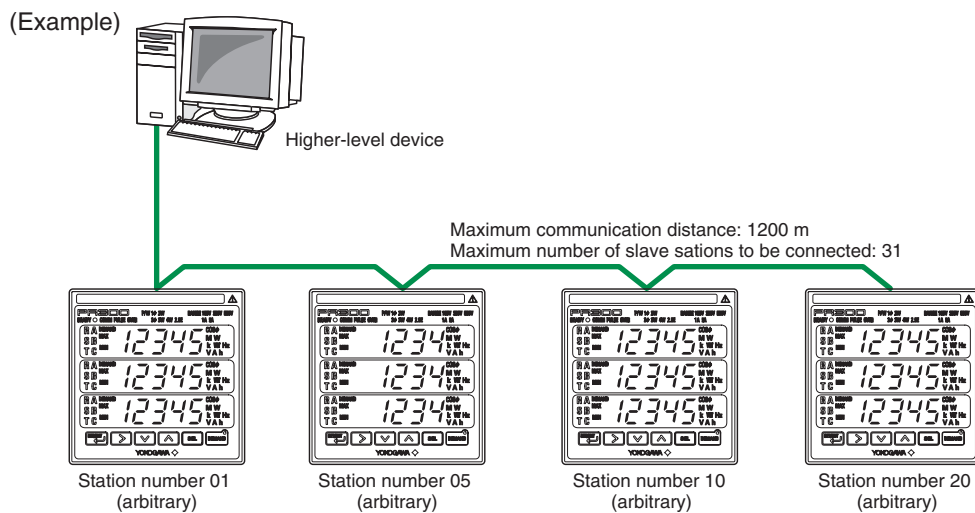

● **Baud rate (B-RT)**

Set the baud rate identical to that of the higher-level device to be connected. (Otherwise, proper communication cannot be achieved.)

● **Parity (PRI)**

Set the handling of parity to be carried out when data is sent or received. Set the parity bit state identical to that of the higher-level device to be connected.

* When PR201 original is selected for the protocol, select NONE for the parity.

● **Stop bit (STP)**

Set the stop bit identical to that of the higher-level device to be connected.

* When PR201 original is selected for the protocol, select 1 for the stop bit.

● **Data length (DLN)**

Set the same data length as for the upper device that is to be connected.

* When Modbus/RTU is selected for the protocol, select 8 for the data length.

* When PR201 original is selected for the protocol, select 8 for the data length.

2.2.2 Conditions for Ethernet Communication

This subsection describes the setting parameters for using the Ethernet communication function, and the setting ranges.

Table 2.2 Parameters to be Set for Communication Functions

Parameter Name	Menu	Parameter Symbol	Setting Range	Initial Value	
Protocol	r485 (RS-485 Communication)	CoMm (COMM)	PC link without checksum	PCLK1 (PCLK1)	PCLK2
			PC link with checksum	PCLK2 (PCLK2)	
			Modbus/ASCII	M ASC (M ASC)	
			Modbus/RTU	M RTU (M RTU)	
			Modbus/TCP*1	M TCP (M TCP)	
			PR201 original	PR201 (PR201)	
IP address-1	Ethr (Ethernet Communication) *2	IP-1 (IP-1)	0 to 255	192	
IP address-2		IP-2 (IP-2)	0 to 255	168	
IP address-3		IP-3 (IP-3)	0 to 255	1	
IP address-4		IP-4 (IP-4)	0 to 255	1	
Subnet mask-1		SM-1 (SM-1)	0 to 255	255	
Subnet mask-2		SM-2 (SM-2)	0 to 255	255	
Subnet mask-3		SM-3 (SM-3)	0 to 255	255	
Subnet mask-4		SM-4 (SM-4)	0 to 255	0	
Default gateway-1		DG-1 (DG-1)	0 to 255	0	
Default gateway-2		DG-2 (DG-2)	0 to 255	0	
Default gateway-3		DG-3 (DG-3)	0 to 255	0	
Default gateway-4		DG-4 (DG-4)	0 to 255	0	
Port number		Port (PORT)	502, 1024 to 65535	502	
Ethernet setting switch		E-SW (E-SW)	OFF, ON	—	

*1: Modbus/TCP can be selected for the PR300 with Ethernet communication function only.

*2: Ethernet communication menu is displayed when Modbus/TCP is selected for the protocol.

● **Protocol (COMM)**

Set the protocol to Modbus/TCP.

● **IP address-1 to 4 (IP-n) [n: integers from 1 to 4]**

Set the IP address for the PR300 by the following format.

0 to 255 0 to 255 0 to 255 0 to 255

IP address . . .

● **Subnet mask-1 to 4 (SM-n) [n: integers from 1 to 4]**

Set the subnet mask for the PR300 by the following format.

0 to 255 0 to 255 0 to 255 0 to 255

Subnet Mask . . .

● **Default gateway-1 to 4 (DG-n) [n: integers from 1 to 4]**

Set the default gateway for the PR300 by the following format.

0 to 255 0 to 255 0 to 255 0 to 255

Default Gateway . . .

 **NOTE**

Before performing setup of IP address, subnet mask, and default gateway, consult the administrator for the network to which the PR300 is to be connected.

● **Port number (PORT)**

Set the port number for the PR300.

 **NOTE**

To activate the settings of IP address, subnet mask, default gateway, and port number, set the Ethernet setting switch to 'ON' after setting them.

● **Ethernet setting switch (E-SW)**

This switch activates the Ethernet communication parameters settings. Setting this parameter to ON activates the settings of IP address, subnet mask, default gateway, and port number.

This parameter automatically reverts to OFF in about 20 seconds after being set to ON.

2.2.3 Conditions for Ethernet-Serial Gateway Function

The Ethernet-serial gateway function is a function that reads/writes data from/to other devices equipped with RS-485 serial communication function using the Modbus/TCP protocol via the PR300.

With this function, the higher-level device can access the devices connected to the RS-485 serial communication line in the same way as to access the devices connected to Ethernet.

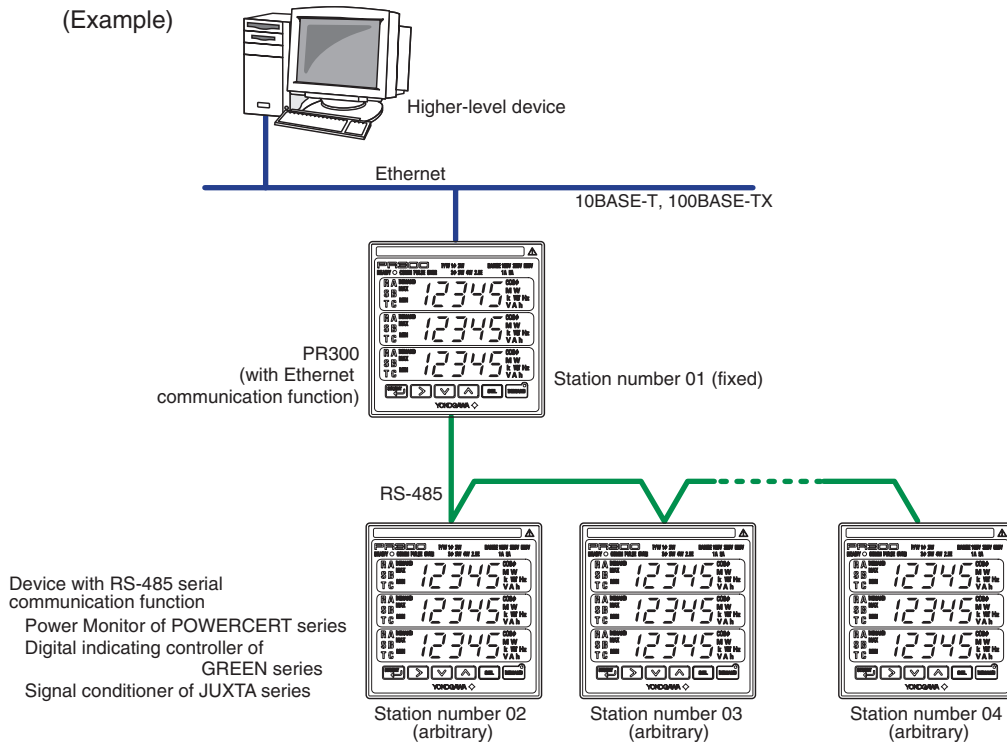

The PR300 operates as a gateway that changes the Modbus/TCP protocol received via network to the Modbus/RTU protocol for the serial devices connected to the RS-485 communication interface. Therefore, the devices supporting the Modbus/RTU protocol are required for the devices to be connected.

 **NOTE**





- If the Ethernet-serial gateway function is used, set a station number other than 01 for the RS-485 communication devices which are slaves of the PR300 connected to Ethernet.
- If the Ethernet communication function is used, the RS-485 communication interface is used specifically for the Ethernet-serial gateway function. Therefore, it is not possible for a higher-level device such as a PC to access the PR300 via the RS-485 communication interface.

● **Setting for PR300 to perform the Ethernet-serial gateway function**

To use the Ethernet-serial gateway function, set the parameters of subsection 2.2.2, “Conditions for Ethernet Communication” and set a parity (PRI) in Table 2.3.

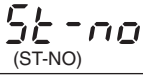
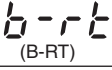
When the protocol is set to Modbus/TCP, the parameters of RS-485 other than the parity are fixed and unchangeable.

Table 2.3 Parameters of PR300 to Perform the Ethernet-Serial Gateway Function





Parameter Name	Menu	Parameter Symbol	Setting Range	Initial Value	
Station number	 (RS-485 communication)	 (ST-NO)	01 (fixed)	01	
Baud rate		 (B-RT)	9600 bps (fixed)	9600	
Parity		 (PRI)	None Even Odd	NONE EVEN ODD	NONE
Stop bit		 (STP)	1 (fixed)	1	
Data length		 (DLN)	8 (fixed)	8	

● **Slave PR300**

The station number of any slave PR300 (device for RS-485 communication) must be a different number other than 01.

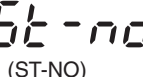
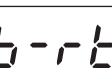
The communication conditions for any slave PR300 (device for RS-485 communication) other than the station number must conform to those in Table 2.3.

Table 2.4 Parameters of Slave PR300

Parameter Name	Menu	Parameter Symbol	Setting Range	Initial Value	
Station number	 (RS-485 communication)	 (ST-NO)	02 to 99	01	
Baud rate		 (B-RT)	2400 bps 9600 bps 19200 bps	9600	
Parity		 (PRI)	None Even Odd	NONE EVEN ODD	NONE
Stop bit		 (STP)	1 2	1	
Data length		 (DLN)	7 8	8	

When using the VJET Ethernet/RS-485 converter as an Ethernet-serial gateway function, the communication conditions of any slave PR300 must conform to those of the VJET at a higher level. The initial value of the VJET parity is EVEN.

2.3 Wiring for Communication

Connect a higher-level device with the PR300 for using the communication functions. The wiring procedures and precautionary notes are as follows.

2.3.1 Wiring for RS-485 Communication

For a common PC, the RS-485 interface is not directly connectable. Use a ML2 RS232C/RS485 converter for wiring.

WARNING

To avoid an electric shock, be sure to turn off the power supply source to the equipment involved before you start wiring.

Use crimp-on terminals at cable ends.

Before you start wiring, read the user's manual of each device.

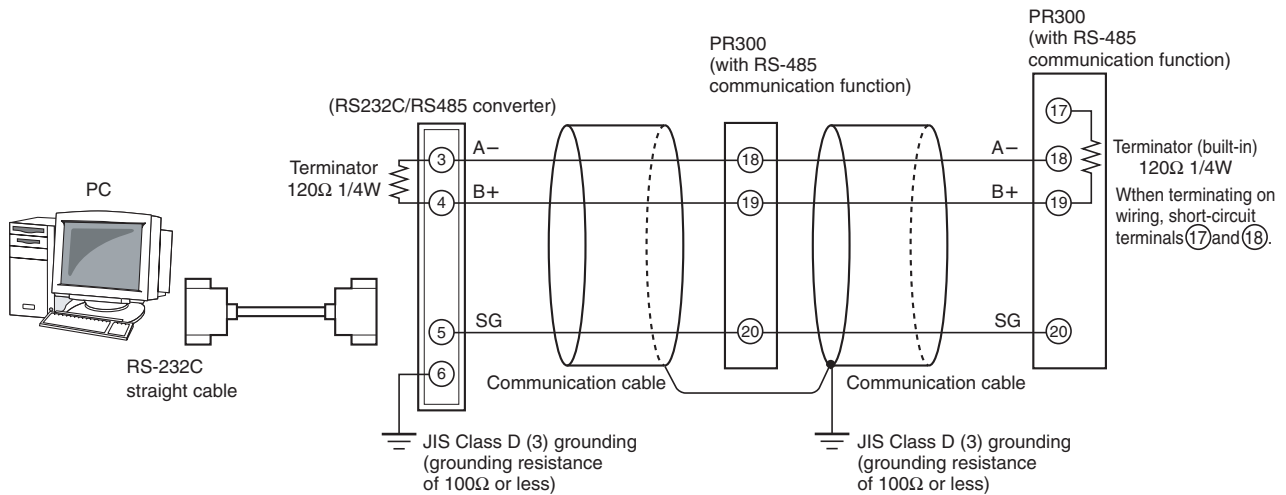

Note: Use UL Listed RS-232C/RS-485 converter if the converter has AC/DC power supply input; this is optional for converters supplied by a Limited Power Source with input voltages less than 30 V AC or 60 V DC and which are separated from mains by double or reinforced insulation.

Communication cable: Shielded twisted pair cable (AWG24-equivalent size)
Recommended terminals: See the PR300 Power and Energy Meter User's Manual (electronic manual).

2.3.2 Wiring for Ethernet Communication

To use the Ethernet communication function, connect a higher-level device with the PR300 with Ethernet communication function using 10BASE-T/100BASE-TX. 10BASE-T/100BASE-TX are Ethernet connection methods using twisted pair cables. The transmission rates are 10 Mbps/100 Mbps. In 10BASE-T/100BASE-TX networks, higher-level devices such as a PC are connected in a star pattern through a hub.

WARNING

To avoid an electric shock, be sure to turn off the power supply source to the equipment involved before you start wiring.

Use hubs and twisted pair cables that conforms to the Ethernet specifications. The maximum number of hubs connectable in cascade configuration is 4 for 10BASE-T and 2 for 100BASE-TX. The maximum allowable length of twisted pair cables is 100 meters.

Read the user's manual of each device carefully before wiring.

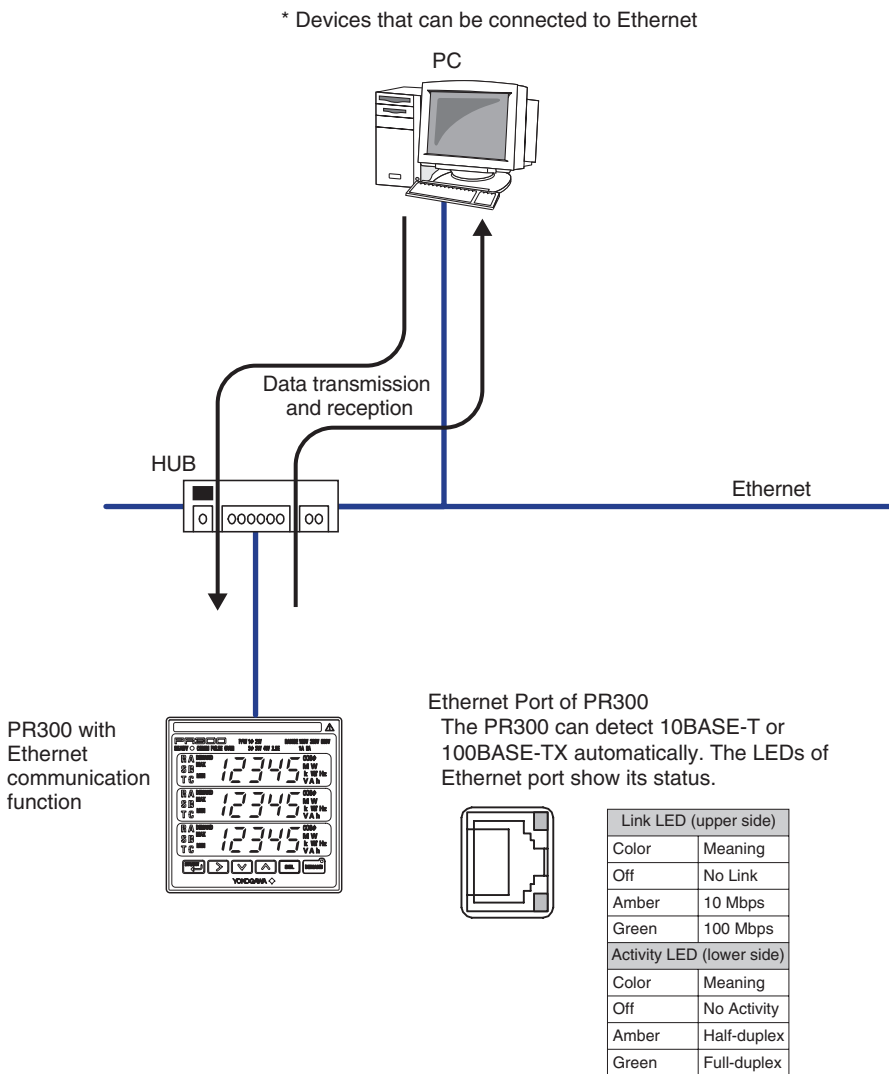

2.3.3 Wiring for RS-485 Communication for Ethernet-Serial Gateway Function

To use the Ethernet-serial gateway function, connect other RS-485 serial communication device to the RS-485 communication terminals .

WARNING

To avoid an electric shock, be sure to turn off the power supply source to the equipment involved before you start wiring.

The figure below shows the example of wiring connection for the PR300 with Ethernet communication function. If other devices are used for connection, the names of communication terminals and others may be different from those mentioned in the figure.

Read the user’s manual of each device carefully before wiring.

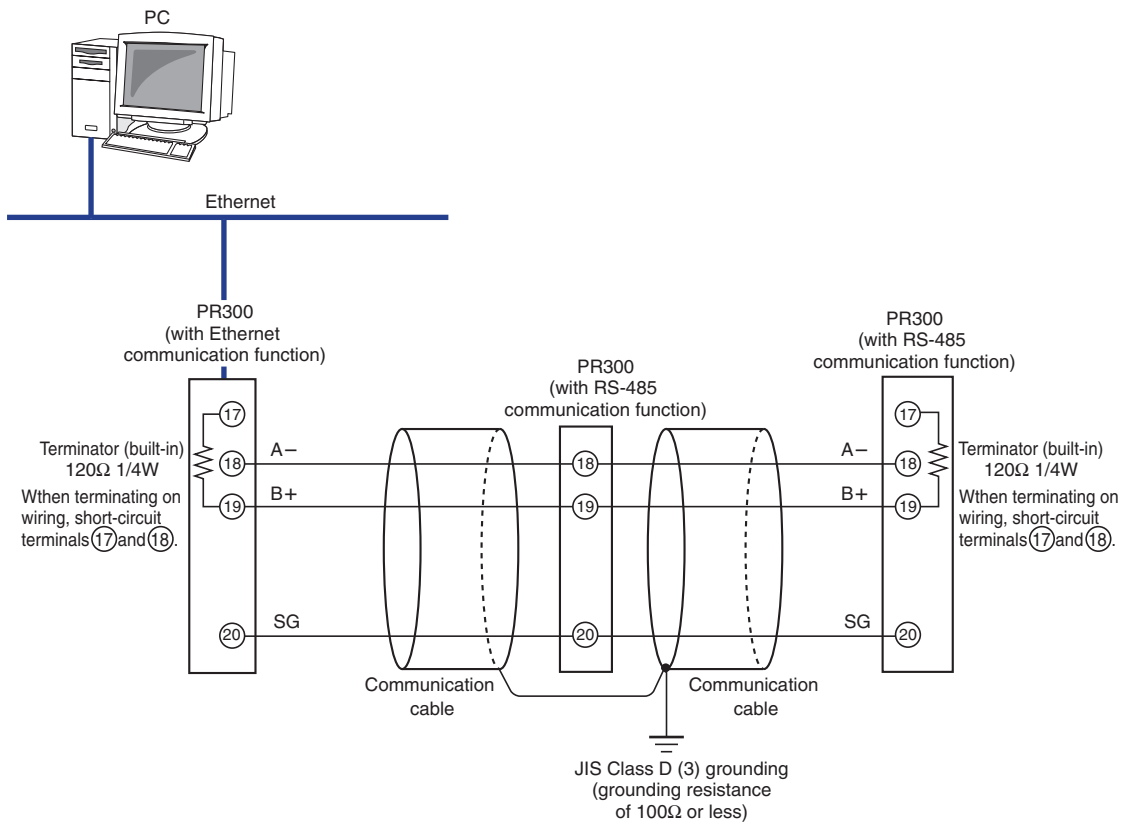

3. Procedures for Setting PR300 Functions

To set the functions of the PR300, use the protocols described in Chapter 4, “PC Link Communication Protocol,” Chapter 5, “Modobus/RTU and ASCII Communication Protocols,” or Chapter 6, “Modbus/TCP Communication Protocol” according to the instructions in this chapter.

For details of each function, refer to the PR300 Power and Energy Meter User’s Manual (electronic manual).

For how to read the tables in this chapter, refer to Chapter 7, “Functions and Usage of D Registers.”

The PR300 offers registers for floating-point data. To perform settings via communication from higher-level device, floating-point data is displayed by IEEE754 (single precision).



NOTE

- The PR300 has data (D register) the unit of which is two words. When 2-word data need to be written or read, writing or reading operations must be performed for the 2-word data at the same time.
 - Even if data written to the D register is out of the effective range, a normal response is returned. The part of the written data within the effective range becomes effective on the PR300 when the equivalent setting change status is written for that data.
-

3.1 Basic Setting

3.1.1 Setting of VT Ratio

[Procedure]

- (1) Write a VT ratio to the two D registers in the table below. The data type is 4-byte floating point.
- (2) After writing that value, write 1 to the setup change status register, D0207.

D Register	Reference No.	H No.	Description	Effective Range
D0201	40201	00C8	VT ratio (float, lower 2 bytes)	1 to 6000
D0202	40202	00C9	VT ratio (float, upper 2 bytes)	
D0207	40207	00CE	Setup change status (D0201 to D0206 are validated)	If other than 1: Invalid If 1: Writing is executed

Initial value of VT ratio: 1 (4-byte floating-point data: 3F800000)

[Example]

To set the VT ratio to 10:

For station number 01, use PC link communication (without checksum) and the random write command as shown below:

If 10 is converted into a 4-byte floating-point value, the value is 4120 0000.

[Command]

[STX] 01010WRW03D0201, 0000, D0202, 4120, D0207, 0001 [ETX] [CR]

[Response]

[STX] 0101OK [ETX] [CR]

 **NOTE**

- When changing the VT ratio, the integrated values of active energy, reactive energy, apparent energy, optional active energy, and regenerative energy will return to "0." The values of the demand alarm point and the scaling of analog output will also be initialized.
- Set the VT and CT ratios so that [secondary rated power] × [VT ratio] × [CT ratio] is smaller than 10 GW. When this value is 10 GW or greater, writing to D registers will be invalid (no error is output).

3.1.2 Setting of CT Ratio

[Procedure]

- (1) Write a CT ratio to the two D registers in the table below. The data type is 4-byte floating point.
- (2) After writing that value, write 1 to the setup change status register, D0207.

D Register	Reference No.	H No.	Description	Effective Range
D0203	40203	00CA	CT ratio (float, lower 2 bytes)	0.05 to 32000
D0204	40204	00CB	CT ratio (float, upper 2 bytes)	
D0207	40207	00CE	Setup change status (D0201 to D0206 are validated)	If other than 1: Invalid If 1: Writing is executed

Initial value of CT ratio: 1 (4-byte floating-point data: 3F800000)

[Example]

To set the CT ratio to 10.0:

For station number 01, use PC link communication (without checksum) and the random write command as shown below:

If 10.0 is converted into a 4-byte floating-point value, the value is 4120 0000.

[Command]

[STX] 01010WRW03D0203, 0000, D0204, 4120, D0207, 0001 [ETX] [CR]

[Response]

[STX] 0101OK [ETX] [CR]



NOTE

- When changing the CT ratio, the integrated values of active energy, reactive energy, apparent energy, optional active energy, and regenerative energy will return to “0.” The values of the demand alarm point and the scaling of analog output will also be initialized.
- Set the VT and CT ratios so that [secondary rated power] × [VT ratio] × [CT ratio] is smaller than 10 GW. When this value is 10 GW or greater, writing to D registers will be invalid (no error is output).

3.1.3 Setting of Integrated Low-cut Power

[Procedure]

- (1) Write an integrated low-cut power value to the two D registers in the table below. The data type is 4-byte floating point.
- (2) After writing that value, write 1 to the setup change status register, D0207.

D Register	Reference No.	H No.	Description	Effective Range
D0205	40205	00CC	Integrated low-cut power (float, lower 2 bytes)	0.05 to 20.00 Unit: %
D0206	40206	00CD	Integrated low-cut power (float, upper 2 bytes)	
D0207	40207	00CE	Setup change status (D0201 to D0206 are validated)	If other than 1: Invalid If 1: Writing is executed

Initial value of integrated low-cut power: 0.05% (4-byte floating-point data: 3D4CCCCD)

[Example]

To set the integrated low-cut power value to 10.0%:

For station number 01, use PC link communication (without checksum) and the random write command as shown below:

If 10.0 is converted into a 4-byte floating-point value, the value is 4120 0000.

[Command]

[STX] 01010WRW03D0205, 0000, D0206, 4120, D0207, 0001 [ETX] [CR]

[Response]

[STX] 0101OK [ETX] [CR]

3.2 Setting Pulse Output

3.2.1 Selection of Measurement Item for Pulse Output

[Procedure]

- (1) Write a measurement item for pulse output value to the D register in the table below. The data type is integer.
- (2) After writing that value, write 1 to the pulse output writing status register, D0211.

D Register	Reference No.	H No.	Description	Effective Range
D0208	40208	00CF	Measurement item for pulse output	0: Active energy 1: Regenerative energy 2: LEAD reactive energy 3: LAG reactive energy 4: Apparent energy
D0211	40211	00D2	Pulse output writing status (D0208, D0209, and D0210 are validated)	If other than 1: Invalid If 1: Writing is executed

Initial value of measurement item for pulse output: 0 (active energy)

[Example]

To set the measurement item for pulse output to 1 (LEAD reactive energy):

For station number 01, use PC link communication (without checksum) and the random write command as shown below:

[Command]

[STX] 01010WRW02D0208, 0001, D0211, 0001 [ETX] [CR]

[Response]

[STX] 0101OK [ETX] [CR]



NOTE

- A measurement item for pulse output value can be set for the PR300 with pulse output.
- When the PR300 is the three-phase four-wire system (2.5 element), the following measurement items can be measured only when the current is in a state of equilibrium:
“2: LEAD reactive energy”, “3: LAG reactive energy” and “4: Apparent energy.”

3.2.2 Pulse Unit

[Procedure]

- (1) Write a pulse unit value to the D register in the table below. The data type is integer.
- (2) After writing that value, write 1 to the pulse output writing status register, D0211.

D Register	Reference No.	H No.	Description	Effective Range
D0209	40209	00D0	Pulse unit	1 to 50,000 Unit: × 100 Wh/pulse
D0211	40211	00D2	Pulse output writing status (D0208, D0209, and D0210 are validated)	If other than 1: Invalid If 1: Writing is executed

Initial value of pulse unit: 10 (1000 Wh/pulse)

[Example]

To set the pulse unit to 100 Wh/pulse, write “0001.”

For station number 01, use PC link communication (without checksum) and the random write command as shown below:

[Command]

[STX]01010WRW02D0209,0001,D0211,0001[ETX][CR]

[Response]

[STX]0101OK[ETX][CR]



NOTE

- A pulse unit value can be set for the PR300 with pulse output.
- To set the pulse unit value via communication, set it to 1/100 the value of the displayed (true) value (e.g., set it to 5 when setting the pulse unit value to 500 Wh/pulse).

3.2.3 ON Pulse Width

- (1) Write an ON pulse width value to the D register in the table below. The data type is integer.
- (2) After writing that value, write 1 to the pulse output writing status register, D0211.

 **NOTE**

When the value to be set for the ON pulse width is greater than the value calculated by the following equation, the value cannot be set:

$$\text{ON pulse width (ms)} \leq \frac{\text{Pulse unit [Wh/pls]} \times 60 \times 60 \times 1000}{\text{Secondary rated power [W]} \times \text{VT ratio} \times \text{CT ratio} \times 1.2 \times 2}$$

D Register	Reference No.	H No.	Description	Effective Range
D0210	40210	00D1	ON pulse width	1 to 127 Unit: × 10 ms
D0211	40211	00D2	Pulse output writing status (D0208, D0209, and D0210 are validated)	If other than 1: Invalid If 1: Writing is executed

Initial value of ON pulse width: 5 (50 ms)

[Example]

To set the ON pulse width to 100 ms, write "000A."

For station number 01, use PC link communication (without checksum) and the random write command as shown below:

[Command]

[STX] 01010WRW02D0210, 000A, D0211, 0001 [ETX] [CR]

[Response]

[STX] 0101OK [ETX] [CR]

 **NOTE**

- An ON pulse width value can be set for the PR300 with pulse output.
- To set the ON pulse width value via communication, set it to 1/10 the value of the displayed (true) value (e.g., set it to 5 when setting the ON pulse width value to 50 ms).

3.3 Setting Analog Output

3.3.1 Selection of Measurement Item for Analog Output

[Procedure]

- (1) Write a measurement item for analog output value to the D register in the table below. The data type is integer.
- (2) After writing that value, write 1 to the analog output writing status register, D0217.

D Register	Reference No.	H No.	Description	Effective Range
D0212	40212	00D3	Measurement item for analog output	0: Active power 1: Reactive power 2: Apparent power 3: Voltage-1 4: Voltage-2 5: Voltage-3 6: Current-1 7: Current-2 8: Current-3 9: Power factor 10: Frequency
D0217	40217	00D8	Analog output writing status (D0212 to D0216 are validated)	If other than 1: Invalid If 1: Writing is executed

Initial value of measurement item for analog output: 0 (active power)

[Example]

To set the measurement item for analog output to 3 (voltage-1):

For station number 01, use PC link communication (without checksum) and the random write command as shown below:

[Command]

[STX] 01010WRW02D0212, 0003, D0217, 0001 [ETX] [CR]

[Response]

[STX] 0101OK [ETX] [CR]



NOTE

- A measurement item for analog output value can be set for the PR300 with analog output.
- Different types of the PR300 can measure different items, and so the values that can be set to the D register differ depending on the PR300 type. If a value that cannot be written to the D register is written, it will be invalid. The table below shows the values that cannot be set for four types of the PR300:

Phase and Wire System	Values that cannot be Set
Single-phase two-wire	4: Voltage-2, 5: Voltage-3, 7: Current-2, and 8: Current-3
Single-phase three-wire	5: Voltage-3 and 8: Current-3
Three-phase three-wire	4: Voltage-2 and 7: Current-2
Three-phase four-wire (2.5 element)	4: Voltage-2 and 7: Current-2

- When the PR300 is the three-phase four-wire system (2.5 element), the following measurement items can be measured only when the current is in a state of equilibrium: “1: Reactive power”, “2: Apparent power”, “6: Current-1”, “8: Current-3” and “9: Power factor.”

3.3.2 Upper/Lower Limits of Scaling

[Procedure]

- (1) Write upper/lower limits of scaling value to the four D registers in the table below. The data type is 4-byte floating point.
- (2) After writing that value, write 1 to the analog output writing status register, D0217.

D Register	Reference No.	H No.	Description	Effective Range
D0213	40213	00D4	Lower limit of scaling (float, lower 2 bytes)	0.0 to 50.0 Unit: %
D0214	40214	00D5	Lower limit of scaling (float, upper 2 bytes)	
D0215	40215	00D6	Upper limit of scaling (float, lower 2 bytes)	50.0 to 100.0 Unit: %
D0216	40216	00D7	Upper limit of scaling (float, upper 2 bytes)	
D0217	40217	00D8	Analog output writing status (D0212 to D0216 are validated)	If other than 1: Invalid If 1: Writing is executed

Initial value of lower limit of scaling: 50%
 Initial value of upper limit of scaling: 100%

[Example]

To set the lower limit of scaling to 10.0%:

For station number 01, use PC link communication (without checksum) and the random write command as shown below:

If 10.0 is converted into a 4-byte floating point value, the value is 4120 0000.

[Command]

[STX] 01010WRW03D0213, 0000, D0214, 4120, D0217,0001 [ETX] [CR]

[Response]

[STX] 0101OK [ETX] [CR]



NOTE

- An upper/lower limit of scaling value can be set for the PR300 with analog output.
- Set an upper/lower limit of scaling so that [upper limit of scaling] – [lower limit of scaling] is 50% or greater. If it is smaller than 50%, writing to the D register will be invalid.

3.4 Demand Setting

3.4.1 Demand Power/Current

[Procedure]

- (1) Write a demand power/current value to the D register in the table below. The data type is integer.
- (2) After writing that value, write 1 to the demand measurement writing status register, D0226.

D Register	Reference No.	H No.	Description	Effective Range
D0218	40218	00D9	Demand power/current	0: Active power 1: Current
D0226	40226	00E1	Demand measurement writing status (D0218 to D0225 are validated)	If other than 1: Invalid If 1: Writing is executed

Initial value of demand power/current: 0 (active power)

[Example]

To set the demand power/current to 1 (current):

For station number 01, use PC link communication (without checksum) and the random write command as shown below:

[Command]

[STX] 01010WRW02D0218, 0001, D0226, 0001 [ETX] [CR]

[Response]

[STX] 0101OK [ETX] [CR]

 **NOTE**

- A demand power/current value can be set for the PR300 with demand measuring function.
- When the PR300 is the three-phase four-wire system (2.5 element), "1: Current" can be measured only when the current is in a state of equilibrium.

3.4.2 Demand Period

[Procedure]

- (1) Write a demand period value to the D register in the table below. The data type is integer.
- (2) After writing that value, write 1 to the demand measurement writing status register, D0226.

D Register	Reference No.	H No.	Description	Effective Range
D0219	40219	00DA	Demand period	1 to 60 (Demand alarm mask time to 60) Unit: minute
D0226	40226	00E1	Demand measurement writing status (D0218 to D0225 are validated)	If other than 1: Invalid If 1: Writing is executed

Initial value of demand period: 30 minutes

[Example]

To set the demand period to 20 minutes:

For station number 01, use PC link communication (without checksum) and the random write command as shown below:

[Command]

[STX] 01010WRW02D0219, 0014, D0226, 0001 [ETX] [CR]

[Response]

[STX] 0101OK [ETX] [CR]



NOTE

A demand period value can be set for the PR300 with demand measuring function.

3.4.3 Demand Alarm Mask Time

[Procedure]

- (1) Write a demand alarm mask time value to the D register in the table below. The data type is integer.
- (2) After writing that value, write 1 to the demand measurement writing status register, D0226.

D Register	Reference No.	H No.	Description	Effective Range
D0220	40220	00DB	Demand alarm mask time	1 to 59 (1 to demand period) Unit: minute
D0226	40226	00E1	Demand measurement writing status (D0218 to D0225 are validated)	If other than 1: Invalid If 1: Writing is executed

Initial value of demand alarm mask time: 1 minute

[Example]

To set the demand alarm mask time to 20 minutes:

For station number 01, use PC link communication (without checksum) and the random write command as shown below:

[Command]

[STX]01010WRW02D0220,0014,D0226,0001[ETX][CR]

[Response]

[STX]0101OK[ETX][CR]



NOTE

A demand alarm mask time value can be set for the PR300 with demand measuring function.

3.4.4 Demand Power Alarm Point

[Procedure]

- (1) Write a demand power alarm point value to the two D registers in the table below. The data type is 4-byte floating point.
- (2) After writing that value, write 1 to the demand measurement writing status register, D0226.

D Register	Reference No.	H No.	Description	Effective Range
D0221	40221	00DC	Demand power alarm point (float, lower 2 bytes)	1 to 1000 Unit: kW
D0222	40222	00DD	Demand power alarm point (float, upper 2 bytes)	
D0226	40226	00E1	Demand measurement writing status (D0218 to D0225 are validated)	If other than 1: Invalid If 1: Writing is executed

Initial value of demand power alarm point: 100 kW

[Example]

To set the demand power alarm point to 10.0 kW:

For station number 01, use PC link communication (without checksum) and the random write command as shown below:

If 10.0 is converted into a 4-byte floating point value, the value is 4120 0000.

[Command]

[STX]01010WRW03D0221,0000,D0222,4120,D0226,0001[ETX][CR]

[Response]

[STX]0101OK[ETX][CR]



A demand power alarm point value can be set for the PR300 with demand measuring function.

3.4.5 Demand Current Alarm Point

[Procedure]

- (1) Write a demand current alarm point value to the two D registers in the table below. The data type is 4-byte floating point.
- (2) After writing that value, write 1 to the demand measurement writing status register, D0226.

D Register	Reference No.	H No.	Description	Effective Range
D0223	40223	00DE	Demand current alarm point (float, lower 2 bytes)	1 to 1000 Unit: A
D0224	40224	00DF	Demand current alarm point (float, upper 2 bytes)	
D0226	40226	00E1	Demand measurement writing status (D0218 to D0225 are validated)	If other than 1: Invalid If 1: Writing is executed

Initial value of demand current alarm point: 100 A

[Example]

To set the demand current alarm point to 10.0 A:

For station number 01, use PC link communication (without checksum) and the random write command as shown below:

If 10.0 is converted into a 4-byte floating point value, the value is 4120 0000.

[Command]

[STX]01010WRW03D0223,0000,D0224,4120,D0226,0001[ETX][CR]

[Response]

[STX]0101OK[ETX][CR]



NOTE

A demand current alarm point value can be set for the PR300 with demand measuring function.

3.4.6 Demand Alarm Release Function

[Procedure]

- (1) Write a demand alarm release function value to the D register in the table below. The data type is integer.
- (2) After writing that value, write 1 to the demand measurement writing status register, D0226.

D Register	Reference No.	H No.	Description	Effective Range
D0225	40225	00E0	Demand alarm release function	0: Automatic release 1: Manual release
D0226	40226	00E1	Demand measurement writing status (D0218 to D0225 are validated)	If other than 1: Invalid If 1: Writing is executed

Initial value of demand alarm release function: 0 (automatic release)

[Example]

To set the demand alarm release function to 0 (automatic release):

For station number 01, use PC link communication (without checksum) and the random write command as shown below:

[Command]

[STX]01010WRW02D0225,0000,D0226,0001[ETX][CR]

[Response]

[STX]0101OK[ETX][CR]



NOTE

- A demand alarm release function value can be set for the PR300 with demand measuring function.
- When the demand alarm release function is used by digital input, releasing via communication is not possible.

3.5 Communication Setting

3.5.1 Protocol

[Procedure]

- (1) Write a protocol value to the D register in the table below. The data type is integer.
- (2) After writing that value, write 1 to the RS-485 writing status register, D0277.

D Register	Reference No.	H No.	Description	Effective Range
D0271	40271	010E	Protocol	0: PC link (without checksum) 1: PC link (with checksum) 2: Modbus/ASCII 3: Modbus/RTU 4: Modbus/TCP *1 5: PR201 original
D0277	40277	0114	RS-485 writing status (D0271 to D0276 are validated)	If other than 1: Invalid If 1: Writing is executed

Initial value of protocol: 1 (PC link with checksum)

*1: Modbus/TCP can be selected for the PR300 with Ethernet communication function only.



NOTE

- When Modbus/TCP is selected for the protocol, the baud rate, the stop bit, the data length and the station number are fixed and unchangeable.
- When PR201 original is selected, the baud rate, the parity, the stop bit and the data length cannot be set via communication.

[Example]

To set the protocol to 4 (Modbus/TCP):

For station number 01, use PC link communication (without checksum) and the random write command as shown below:

[Command]

[STX]01010WRW02D0271,0004,D0277,0001[ETX][CR]

[Response]

[STX]0101OK[ETX][CR]

3.5.2 Baud Rate

[Procedure]

- (1) Write a baud rate value to the D register in the table below. The data type is integer.
- (2) After writing that value, write 1 to the RS-485 writing status register, D0277.

D Register	Reference No.	H No.	Description	Effective Range
D0272	40272	010F	Baud rate	0: 2400 bps 1: 9600 bps 2: 19200 bps
D0277	40277	0114	RS-485 writing status (D0271 to D0276 are validated)	If other than 1: Invalid If 1: Writing is executed

Initial value of baud rate: 1 (9600 bps)



NOTE

When Modbus/TCP is selected for the protocol, the baud rate is fixed and unchangeable at 9600 bps.

[Example]

To set the baud rate to 2 (19200 bps):

For station number 01, use PC link communication (without checksum) and the random write command as shown below:

[Command]

[STX]01010WRW02D0272,0002,D0277,0001[ETX][CR]

[Response]

[STX]0101OK[ETX][CR]

3.5.3 Parity

[Procedure]

- (1) To set the parity, write data to the D register in the table below. The data type is integer.
- (2) After writing that value, write 1 to the RS-485 writing status register, D0277.

D Register	Reference No.	H No.	Description	Effective Range
D0273	40273	0110	Parity	0: NONE 1: EVEN 2: ODD
D0277	40277	0114	RS-485 writing status (D0271 to D0276 are validated)	If other than 1: Invalid If 1: Writing is executed

Initial value of parity: 0 (NONE)

[Example]

To set the parity to 1 (EVEN):

For station number 01, use PC link communication (without checksum) and the random write command as shown below:

[Command]

[STX]01010WRW02D0273,0001,D0277,0001[ETX][CR]

[Response]

[STX]0101OK[ETX][CR]

3.5.4 Stop Bit

[Procedure]

- (1) To set the stop bit, write data to the D register in the table below. The data type is integer.
- (2) After writing that value, write 1 to the RS-485 writing status register, D0277.

D Register	Reference No.	H No.	Description	Effective Range
D0274	40274	0111	Stop bit	1: 1 bit 2: 2 bits
D0277	40277	0114	RS-485 writing status (D0271 to D0276 are validated)	If other than 1: Invalid If 1: Writing is executed

Initial value of stop bit: 1 (1 bit)



NOTE

When Modbus/TCP is selected for the protocol, the stop bit is fixed and unchangeable at 1 bit.

[Example]

To set the stop bit to 2 (2 bits):

For station number 01, use PC link communication (without checksum) and the random write command as shown below:

[Command]

[STX]01010WRW02D0274,0002,D0277,0001[ETX][CR]

[Response]

[STX]0101OK[ETX][CR]

3.5.5 Data Length

[Procedure]

- (1) To set the data length, write data to the D register in the table below. The data type is integer.
- (2) After writing that value, write 1 to the RS-485 writing status register, D0277.

D Register	Reference No.	H No.	Description	Effective Range
D0275	40275	0112	Data length	0: 8 bits 1: 7 bits
D0277	40277	0114	RS-485 writing status (D0271 to D0276 are validated)	If other than 1: Invalid If 1: Writing is executed

Initial value of data length: 0 (8 bits)



NOTE

When Modbus/TCP is selected for the protocol, the data length is fixed and unchangeable at 8 bits.

[Example]

To set the data length to 1 (7 bits):

For station number 01, use PC link communication (without checksum) and the random write command as shown below:

[Command]

[STX]01010WRW02D0275,0001,D0277,0001[ETX][CR]

[Response]

[STX]0101OK[ETX][CR]

3.5.6 Station Number

[Procedure]

- (1) To set the station number, write data to the D register in the table below. The data type is integer.
- (2) After writing that value, write 1 to the RS-485 writing status register, D0277.

D Register	Reference No.	H No.	Description	Effective Range
D0276	40276	0113	Station number	01 to 99
D0277	40277	0114	RS-485 writing status (D0271 to D0276 are validated)	If other than 1: Invalid If 1: Writing is executed

Initial value of station number: 01



NOTE

When Modbus/TCP is selected for the protocol, the station number is fixed and unchangeable at 01.

[Example]

To set the station number to 02:

For station number 01, use PC link communication (without checksum) and the random write command as shown below:

[Command]

[STX]01010WRW02D0276,0002,D0277,0001[ETX][CR]

[Response]

[STX]0101OK[ETX][CR]

3.5.7 IP Address (for Ethernet communication)

[Procedure]

- (1) To set the IP address, write data to the four D registers in the table below. The data type is integer.
- (2) After writing that value, write 1 to the Ethernet writing status register, D0294.

D Register	Reference No.	H No.	Description	Effective Range
D0281	40281	0118	IP address-1 (IP-1)	0 to 255
D0282	40282	0119	IP address-2 (IP-2)	0 to 255
D0283	40283	011A	IP address-3 (IP-3)	0 to 255
D0284	40284	011B	IP address-4 (IP-4)	0 to 255
D0294	40294	0125	Ethernet writing status (D0281 to D0293 are validated)	If other than 1: Invalid If 1: Writing is executed

Initial value of IP address: 192.168.1.1

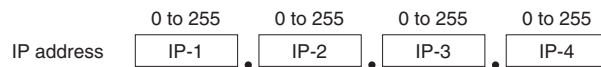

 **NOTE**

- An IP address value can be set for the PR300 with Ethernet communication function.
- IP address settings are only effective when the protocol is set to Modbus/TCP.

[Example]

To set the IP address to 192.168.1.3:

For station number 01, use PC link communication (without checksum) and the random write command as shown below:

[Command]

[STX]01010WRW05D0281,00C0,D0282,00A8,D0283,0001,D0284,0003,D0294,0001[ETX][CR]

[Response]

[STX]0101OK[ETX][CR]

3.5.8 Subnet Mask (for Ethernet communication)

[Procedure]

- (1) To set the subnet mask, write data to the four D registers in the table below. The data type is integer.
- (2) After writing that value, write 1 to the Ethernet writing status register, D0294.

D Register	Reference No.	H No.	Description	Effective Range
D0285	40285	011C	Subnet mask-1 (SM-1)	0 to 255
D0286	40286	011D	Subnet mask-2 (SM-2)	0 to 255
D0287	40287	011E	Subnet mask-3 (SM-3)	0 to 255
D0288	40288	011F	Subnet mask-4 (SM-4)	0 to 255
D0294	40294	0125	Ethernet writing status (D0281 to D0293 are validated)	If other than 1: Invalid If 1: Writing is executed

Initial value of subnet mask: 255.255.255.0

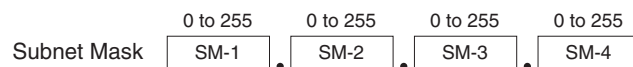

 **NOTE**

- A subnet mask value can be set for the PR300 with Ethernet communication function.
- Subnet mask settings are only effective when the protocol is set to Modbus/TCP.

[Example]

To set the subnet mask to 255. 255. 255. 0:

For station number 01, use PC link communication (without checksum) and the random write command as shown below:

[Command]

[STX]01010WRW05D0285,00FF,D0286,00FF,D0287,00FF,D0288,0000,D0294,0001[ETX][CR]

[Response]

[STX]0101OK[ETX][CR]

3.5.9 Default Gateway (for Ethernet communication)

[Procedure]

- (1) To set the default gateway, write data to the four D registers in the table below. The data type is integer.
- (2) After writing that value, write 1 to the Ethernet writing status register, D0294.

D Register	Reference No.	H No.	Description	Effective Range
D0289	40289	0120	Default gateway-1 (DG-1)	0 to 255
D0290	40290	0121	Default gateway-2 (DG-2)	0 to 255
D0291	40291	0122	Default gateway-3 (DG-3)	0 to 255
D0292	40292	0123	Default gateway-4 (DG-4)	0 to 255
D0294	40294	0125	Ethernet writing status (D0281 to D0293 are validated)	If other than 1: Invalid If 1: Writing is executed

Initial value of default gateway: 0.0.0.0

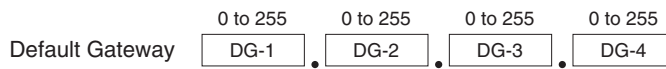

 **NOTE**

- A default gateway value can be set for the PR300 with Ethernet communication function.
- Default gateway settings are only effective when the protocol is set to Modbus/TCP.

[Example]

To set the default gateway to 0. 0. 0. 0:

For station number 01, use PC link communication (without checksum) and the random write command as shown below:

[Command]

[STX]01010WRW05D0289,0000,D0290,0000,D0291,0000,D0292,0000,D0294,0001[ETX][CR]

[Response]

[STX]0101OK[ETX][CR]

3.5.10 Port Number (for Ethernet communication)

[Procedure]

- (1) To set the port number, write data to the D register in the table below. The data type is integer.
- (2) After writing that value, write 1 to the Ethernet writing status register, D0294.

D Register	Reference No.	H No.	Description	Effective Range
D0293	40293	0124	Port number	502, 1024 to 65535
D0294	40294	0125	Ethernet writing status (D0281 to D0293 are validated)	If other than 1: Invalid If 1: Writing is executed

Initial value of port number: 502



NOTE

- A port number value can be set for the PR300 with Ethernet communication function.
- Port number setting is only effective when the protocol is set to Modbus/TCP.

[Example]

To set the port number to 1024:

For station number 01, use PC link communication (without checksum) and the random write command as shown below:

[Command]

[STX]01010WRW02D0293,0400,D0294,0001[ETX][CR]

[Response]

[STX]0101OK[ETX][CR]

3.6 Writing Energy Values

3.6.1 Active Energy

[Procedure]

- (1) Write an active energy value to the two D registers in the table below. The data type is integer.
- (2) After writing that value, write 1 to the writing status register, D0373.

D Register	Reference No.	H No.	Description	Effective Range
D0371	40371	0172	Active energy-setpoint (lower 2 bytes)	Refer to the "NOTE" below.
D0372	40372	0173	Active energy-setpoint (upper 2 bytes)	
D0373	40373	0174	Active energy value writing status	If other than 1: Invalid If 1: Writing is executed

[Example]

To set the active energy value to 10,000,000 kWh:

For station number 01, use PC link communication (without checksum) and the random write command as shown below:

If 10,000,000 is converted into a hexadecimal value, the value is 0098 9680. Then the order of the upper two bytes and the lower two bytes is reversed ⇒ 9680 0098.

[Command]

[STX] 01010WRW03D0371, 9680, D0372, 0098, D0373, 0001 [ETX] [CR]

[Response]

[STX] 0101OK [ETX] [CR]



NOTE

The set active energy value range of the PR300 changes depending on the values of the VT and CT ratios. The table below shows the set value range.

[Secondary Rated Power] × [VT Ratio] × [CT Ratio]	Possible Set Value Range
Less than 100 kW	0 to 99999 kWh
100 kW to less than 1 MW	0 to 999999 kWh
1 MW to less than 10 MW	0 to 9999999 kWh
10 MW or greater	0 to 99999999 kWh



NOTE

The secondary rated power of the PR300 changes depending on its model and suffix codes.

3.6.2 Regenerative Energy

[Procedure]

- (1) Write a regenerative energy value to the two D registers in the table below. The data type is integer.
- (2) After writing that value, write 1 to the writing status register, D0376.

D Register	Reference No.	H No.	Description	Effective Range
D0374	40374	0175	Regenerative energy-setpoint (lower 2 bytes)	Refer to the "NOTE" below.
D0375	40375	0176	Regenerative energy-setpoint (upper 2 bytes)	
D0376	40376	0177	Regenerative energy writig status	If other than 1: Invalid If 1: Writing is executed

[Example]

To set the regenerative energy value to 10,000,000 kWh:

For station number 01, use PC link communication (without checksum) and the random write command as shown below:

If 10,000,000 is converted into a hexadecimal value, the value is 0098 9680. Then the order of the upper two bytes and the lower two bytes is reversed ⇒ 9680 0098.

[Command]

[STX] 01010WRW03D0374, 9680, D0375, 0098, D0376, 0001 [ETX] [CR]

[Response]

[STX] 0101OK [ETX] [CR]



NOTE

The set regenerative energy value range of the PR300 changes depending on the values of the VT and CT ratios. The table below shows the set value range.

[Secondary Rated Power] × [VT Ratio] × [CT Ratio]	Possible Set Value Range
Less than 100 kW	0 to 99999 kWh
100 kW to less than 1 MW	0 to 999999 kWh
1 MW to less than 10 MW	0 to 9999999 kWh
10 MW or greater	0 to 99999999 kWh



NOTE

The secondary rated power of the PR300 changes depending on its model and suffix codes.

3.6.3 LEAD Reactive Energy

[Procedure]

- (1) Write a LEAD reactive energy value to the two D registers in the table below. The data type is integer.
- (2) After writing that value, write 1 to the writing status register, D0381.

D Register	Reference No.	H No.	Description	Effective Range
D0377	40377	0178	LEAD reactive energy-setpoint (lower 2 bytes)	Refer to the "NOTE" below.
D0378	40378	0179	LEAD reactive energy-setpoint (upper 2 bytes)	
D0381	40381	017C	Reactive energy writing status (D0377 to D0380 are validated)	If other than 1: Invalid If 1: Writing is executed

[Example]

To set the LEAD reactive energy value to 10,000,000 kvarh:

For station number 01, use PC link communication (without checksum) and the random write command as shown below:

If 10,000,000 is converted into a hexadecimal value, the value is 0098 9680. Then the order of the upper two bytes and the lower two bytes is reversed ⇒ 9680 0098.

[Command]

[STX] 01010WRW03D0377, 9680, D0378, 0098, D0381, 0001 [ETX] [CR]

[Response]

[STX] 0101OK [ETX] [CR]



NOTE

The set LEAD reactive energy value range of the PR300 changes depending on the values of the VT and CT ratios. The table below shows the set value range.

[Secondary Rated Power] × [VT Ratio] × [CT Ratio]	Possible Set Value Range
Less than 100 kW	0 to 99999 kvarh
100 kW to less than 1 MW	0 to 999999 kvarh
1 MW to less than 10 MW	0 to 9999999 kvarh
10 MW or greater	0 to 99999999 kvarh



NOTE

The secondary rated power of the PR300 changes depending on its model and suffix codes.

3.6.4 LAG Reactive Energy

[Procedure]

- (1) Write a LAG reactive energy value to the two D registers in the table below. The data type is integer.
- (2) After writing that value, write 1 to the writing status register, D0381.

D Register	Reference No.	H No.	Description	Effective Range
D0379	40379	017A	LAG reactive energy-setpoint (lower 2 bytes)	Refer to the "NOTE" below.
D0380	40380	017B	LAG reactive energy-setpoint (upper 2 bytes)	
D0381	40381	017C	Reactive energy writing status (D0377 to D0380 are validated)	If other than 1: Invalid If 1: Writing is executed

[Example]

To set the LAG reactive energy value to 10,000,000 kvarh:

For station number 01, use PC link communication (without checksum) and the random write command as shown below:

If 10,000,000 is converted into a hexadecimal value, the value is 0098 9680. Then the order of the upper two bytes and the lower two bytes is reversed ⇒ 9680 0098.

[Command]

[STX] 01010WRW03D0379, 9680, D0380, 0098, D0381, 0001 [ETX] [CR]

[Response]

[STX] 0101OK [ETX] [CR]



NOTE

The set LAG reactive energy value range of the PR300 changes depending on the values of the VT and CT ratios. The table below shows the set value range.

[Secondary Rated Power] × [VT Ratio] × [CT Ratio]	Possible Set Value Range
Less than 100 kW	0 to 99999 kvarh
100 kW to less than 1 MW	0 to 999999 kvarh
1 MW to less than 10 MW	0 to 9999999 kvarh
10 MW or greater	0 to 99999999 kvarh



NOTE

The secondary rated power of the PR300 changes depending on its type.

3.6.5 Apparent Energy

[Procedure]

- (1) Write an apparent energy value to the two D registers in the table below. The data type is integer.
- (2) After writing that value, write 1 to the writing status register, D0384.

D Register	Reference No.	H No.	Description	Effective Range
D0382	40382	017D	Apparent energy-setpoint (lower 2 bytes)	Refer to the "NOTE" below.
D0383	40383	017E	Apparent energy-setpoint (upper 2 bytes)	
D0384	40384	017F	Apparent energy writing status	If other than 1: Invalid If 1: Writing is executed

[Example]

To set the apparent energy value to 10,000,000 kVAh:

For station number 01, use PC link communication (without checksum) and the random write command as shown below:

If 10,000,000 is converted into a hexadecimal value, the value is 0098 9680. Then the order of the upper two bytes and the lower two bytes is reversed ⇒ 9680 0098.

[Command]

[STX] 01010WRW03D0382, 9680, D0383, 0098, D0384, 0001 [ETX] [CR]

[Response]

[STX] 0101OK [ETX] [CR]

 **NOTE**

The set apparent energy value range of the PR300 changes depending on the values of the VT and CT ratios. The table below shows the set value range.

[Secondary Rated Power] × [VT Ratio] × [CT Ratio]	Possible Set Value Range
Less than 100 kW	0 to 99999 kVAh
100 kW to less than 1 MW	0 to 999999 kVAh
1 MW to less than 10 MW	0 to 9999999 kVAh
10 MW or greater	0 to 99999999 kVAh

 **NOTE**

The secondary rated power of the PR300 changes depending on its model and suffix codes.

3.7 Executing Reset Operations

3.7.1 Remote Reset

[Procedure]

(1) To execute remote reset, write data to the D register in the table below. The data type is integer.

D Register	Reference No.	H No.	Description	Effective Range
D0400	40400	018F	Remote reset	If other than 1: Invalid If 1: PR300 reset

Initial value of remote reset: 0



NOTE

- When remote reset is executed, maximum, minimum and instantaneous voltage values and maximum and instantaneous current values will be reset. Optional integration is terminated if it is being performed.
- Even when remote reset is executed, active energy, reactive energy, and apparent energy data as well as set parameter values are retained.

[Example]

To execute remote reset:

For station number 01, use PC link communication (without checksum) and the random write command as shown below:

[Command]

[STX] 01010WRW01D0400, 0001 [ETX] [CR]

[Response]

[STX] 0101OK [ETX] [CR]



NOTE

After remote reset is executed, wait for 10 seconds or more before sending another command. It takes about 10 seconds to reset.

Even when PR300 was reset by power supply switch off/on, also wait for 10 seconds or more before sending another command.

3.7.2 Maximum/Minimum Values Reset

[Procedure]

- (1) To execute maximum/minimum values reset, write data to the D register in the table below. The data type is integer.

D Register	Reference No.	H No.	Description	Effective Range
D0351	40351	015E	Maximum/minimum values (D0101 to D0138) reset	If other than 1: Invalid If 1: Maximum/minimum values reset

[Example]

To execute maximum/minimum values reset:

For station number 01, use PC link communication (without checksum) and the random write command as shown below:

[Command]

[STX]01010WRW01D0351,0001[ETX][CR]

[Response]

[STX]0101OK[ETX][CR]

3.7.3 Energy Value All-Reset

[Procedure]

- (1) To execute energy value all-reset, write data to the D register in the table below. The data type is integer.

D Register	Reference No.	H No.	Description	Effective Range
D0352	40352	015F	Energy value all-reset Relevant items are as follows: Active energy (D0001, D0002) Regenerative energy (D0003, D0004) LEAD reactive energy (D0005, D0006) LAG reactive energy (D0007, D0008) Apparent energy (D0009, D0010)	If other than 1: Invalid If 1: Energy value all-reset

[Example]

To execute energy value all-reset:

For station number 01, use PC link communication (without checksum) and the random write command as shown below:

[Command]

[STX]01010WRW01D0352,0001[ETX][CR]

[Response]

[STX]0101OK[ETX][CR]

3.7.4 Active Energy Reset

[Procedure]

- (1) To execute active energy reset, write data to the D register in the table below. The data type is integer.

D Register	Reference No.	H No.	Description	Effective Range
D0353	40353	0160	Active energy (D0001 and D0002) reset	If other than 1: Invalid If 1: Active energy reset

[Example]

To execute active energy reset:

For station number 01, use PC link communication (without checksum) and the random write command as shown below:

[Command]

[STX] 01010WRW01D0353, 0001 [ETX] [CR]

[Response]

[STX] 0101OK [ETX] [CR]

3.7.5 Regenerative Energy Reset

[Procedure]

- (1) To execute regenerative energy reset, write data to the D register in the table below. The data type is integer.

D Register	Reference No.	H No.	Description	Effective Range
D0354	40354	0161	Regenerative energy (D0003 and D0004) reset	If other than 1: Invalid If 1: Regenerative energy reset

[Example]

To execute regenerative energy reset:

For station number 01, use PC link communication (without checksum) and the random write command as shown below:

[Command]

[STX] 01010WRW01D0354, 0001 [ETX] [CR]

[Response]

[STX] 0101OK [ETX] [CR]

3.7.6 Reactive Energy Reset

[Procedure]

- (1) To execute reactive energy reset, write data to the D register in the table below. The data type is integer.

D Register	Reference No.	H No.	Description	Effective Range
D0355	40355	0162	Reactive energy (D0005 to D0008) reset	If other than 1: Invalid If 1: Reactive energy reset

[Example]

To execute reactive energy reset:

For station number 01, use PC link communication (without checksum) and the random write command as shown below:

[Command]

[STX] 01010WRW01D0355, 0001 [ETX] [CR]

[Response]

[STX] 0101OK [ETX] [CR]

3.7.7 Apparent Energy Reset

[Procedure]

- (1) To execute apparent energy reset, write data to the D register in the table below. The data type is integer.

D Register	Reference No.	H No.	Description	Effective Range
D0356	40356	0163	Apparent energy (D0009 and D0010) reset	If other than 1: Invalid If 1: Apparent energy reset

[Example]

To execute apparent energy reset:

For station number 01, use PC link communication (without checksum) and the random write command as shown below:

[Command]

[STX] 01010WRW01D0356, 0001 [ETX] [CR]

[Response]

[STX] 0101OK [ETX] [CR]

3.8 Setting Control States

3.8.1 Integration Start/Stop

[Procedure]

- (1) To execute integration start/stop, write data to the D register in the table below. The data type is integer.

D Register	Reference No.	H No.	Description	Effective Range
D0301	40301	012C	Integration start/stop Relevant items are as follows: Active energy (D0001, D0002) Regenerative energy (D0003, D0004) LEAD reactive energy (D0005, D0006) LAG reactive energy (D0007, D0008) Apparent energy (D0009, D0010)	0: Stop 1: Start

Initial value of integration start/stop: 1 (start)

[Example]

To execute integration start/stop:

For station number 01, use PC link communication (without checksum) and the random write command as shown below:

<For start>

[Command]

[STX] 01010WRW01D0301, 0001 [ETX] [CR]

[Response]

[STX] 0101OK [ETX] [CR]

<For stop>

[Command]

[STX] 01010WRW01D0301, 0000 [ETX] [CR]

[Response]

[STX] 0101OK [ETX] [CR]

3.8.2 Optional Integration Start/Stop

[Procedure]

- (1) To execute optional integration start/stop, write data to the D register in the table below. The data type is integer.

D Register	Reference No.	H No.	Description	Effective Range
D0302	40302	012D	Optional integration start/stop Relevant D registers: D0011 to D0014	0: Stop 1: Start

Initial value of optional integration start/stop: 0 (stop)

 **NOTE**

Optional integration start/stop can also be controlled by digital input. Once digital input is performed, it is the only means for such control. Control via communication is no longer possible until the power is turned off or remote reset is executed (see subsection 3.7.1). However, for the PR300 with demand measuring function, digital input is used to release the demand alarm. In this case, optional integration start/stop cannot be used.

[Control via communication]

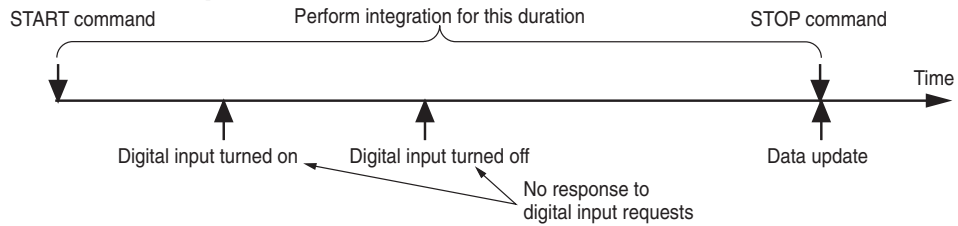

[Control by digital input]

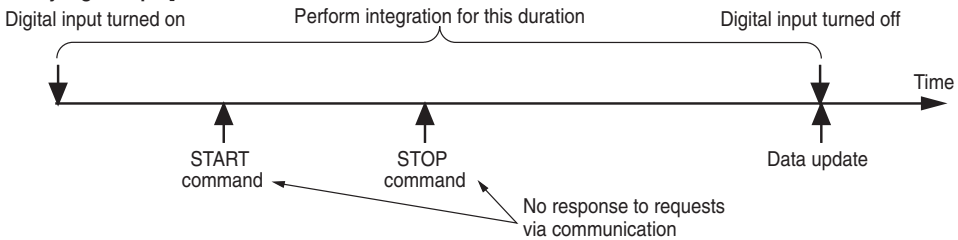

[Example]

To execute optional integration start/stop:

For station number 01, use PC link communication (without checksum) and the random write command as shown below:

[Command]

[STX]01010WRW01D0302,0001[ETX][CR]

[Response]

[STX]0101OK[ETX][CR]

3.8.3 Demand Measurement Start/Stop

[Procedure]

- (1) To execute demand measurement start/stop, write data to the D register in the table below. The data type is integer.

D Register	Reference No.	H No.	Description	Effective Range
D0311	40311	0136	Demand measurement start/stop Relevant items are as follows: Demand power (D0043, D0044) Demand current (D0045 to D0050)	0: Measurement stop 1: Measurement start

Initial value of demand measurement start/stop: 0 (measurement stop)



NOTE

Demand measurement start/stop can also be controlled by operation key. Once the operation key is used, it is the only means for such control. Control via communication is not possible until the power is turned off, or remote reset is executed (see subsection 3.7.1).

[Control via communication]

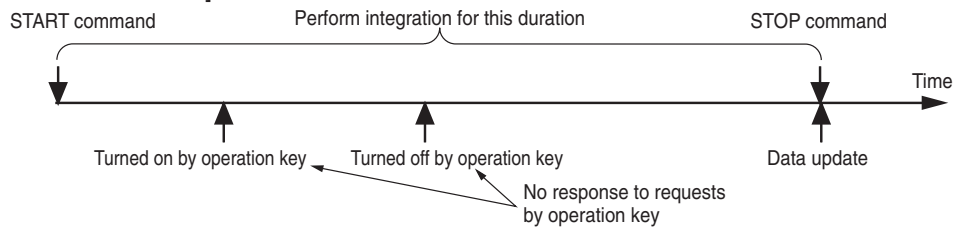

[Control by operation key]

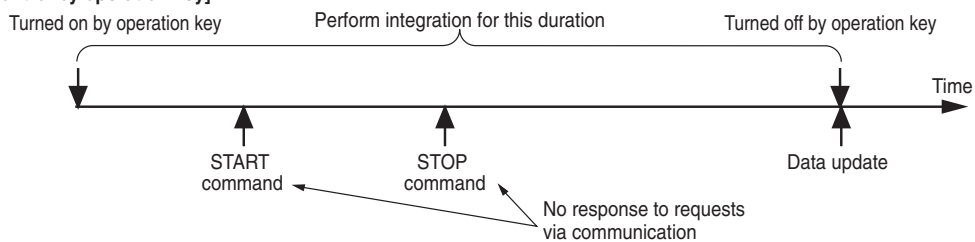

[Example]

To execute demand measurement start/stop:

For station number 01, use PC link communication (without checksum) and the random write command as shown below:

```

<For start>
[Command]
[STX]01010WRW01D0311,0001[ETX][CR]
[Response]
[STX]0101OK[ETX][CR]
<For stop>
[Command]
[STX]01010WRW01D0311,0000[ETX][CR]
[Response]
[STX]0101OK[ETX][CR]

```



NOTE

Demand measurement start/stop can be performed for the PR300 with demand measuring function.

3.8.4 Confirmation and Release of Demand Alarm State

[Procedure]

- (1) To execute confirmation and release of demand alarm state, write data to the D register in the table below. The data type is integer.

D Register	Reference No.	H No.	Description	Effective Range
D0312	40312	0137	Confirmation and release of demand alarm state	0: Normal state 1: Alarm state Writing "0" during alarm state clears the alarm

[Example]

To execute confirmation of demand alarm state:

For station number 01, use PC link communication (without checksum) and the word-basis read (write) command as shown below:

<For read>

[Command]

[STX]01010WRDD0312,01[ETX][CR]

[Response]

[STX]01010OK0001[ETX][CR]

<For write>

[Command]

[STX]01010WWRD0312,01,0000[ETX][CR]

[Response]

[STX]01010OK[ETX][CR]

 **NOTE**

Confirmation and release of demand alarm state can be set for the PR300 with demand measuring function.

4. PC Link Communication Protocol

4.1 Overview

The use of PC link communication enables the PR300 to communicate with a device such as a PC or FA-M3(PLC)'s UT link module. Such a device can be used in communication to read/write data from/to D registers which are internal registers of the PR300.

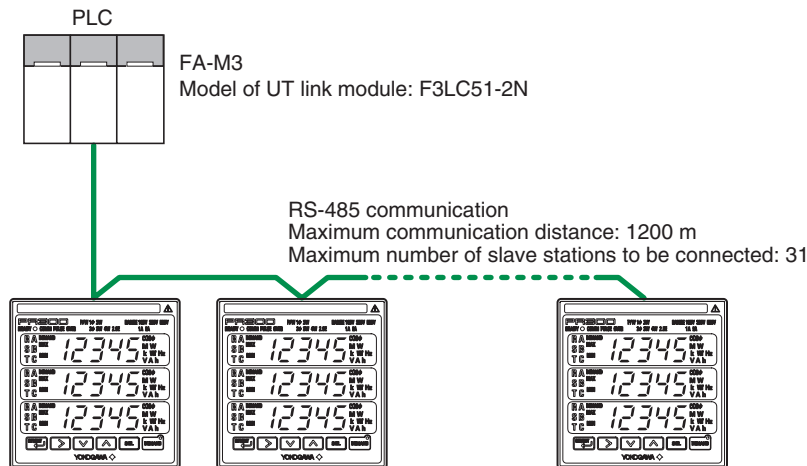

Figure 4.1 Example of Connection for PC Link Communication

Hereafter, PCs are generically called “higher-level devices.”

In PC link communication, a higher-level device identifies each PR300 with a station number of 01 to 99.

NOTE

- The PR300 has data (D register) the unit of which is two words. When 2-word data need to be written or read, writing or reading operations must be performed for the 2-word data at the same time.
- Even if data written to the D register is out of the effective range, a normal response is returned. The part of the written data within the effective range becomes effective on the PR300 when the equivalent setup change status is written for that data.

4.1.1 Configuration of Command

Commands sent from a higher-level device to the PR300 consist of the following elements.

Number of Bytes	1	2	2	1	3	Variable length	2	1	1
Element	STX	Station number (ST-NO)	CPU number 01	Time to wait for response 0	Command	Data corresponding to command	Checksum	ETX	CR
	(1)	(2)	(3)	(4)	(5)	(6)	(7)	(8)	(9)

(1) STX (Start of Text)

This control code indicates the start of a command. The ASCII code is 02 in hexadecimal.

(2) Station Number (01 to 99)

Station numbers are used by the higher-level device to identify the PR300 at the communication destination. (These numbers are identification numbers specific to individual PR300.) P1: Broadcasting mode (See subsection 4.1.4, "Specifying Broadcast")

(3) CPU number

This number is fixed to '01.' The ASCII codes are 30 and 31 in hexadecimal.

(4) Time to Wait for Response

This is fixed to '0'. The ASCII code is 30 in hexadecimal.

(5) Command (See section 4.2, "Command and Response")

Specify a command to be issued from the higher-level device.

(6) Data Corresponding to Command

Specify an internal register (D register), number of data pieces, and others.

(7) Checksum

This is required if the protocol with checksum is selected for the RS-485 communication protocol parameter COMM.

It converts the ASCII codes of texts between the character next to STX and the character immediately before the checksum into hexadecimal values and adds them byte by byte. It then fetches the single lowermost byte of the added results as the checksum.

This column is required only for PC link communication with checksum. PC link communication without checksum does not require this 2-byte space of ASCII code.

[Example]

[STX]01010WRDD0001, 02□□ [ETX][CR]

Add up the hexadecimal values of the ASCII codes of each text.

('0' : 30, '1' : 31, 'W' : 57, 'R' : 52, 'D' : 44, ',' : 2C, '2' : 32)

$$30+31+30+31+30+57+52+44+44+30+30+30+31+2C+30+32 = 372$$

Lowermost two digits of the added results as the checksum.

[STX]01010WRDD0001,0272[ETX][CR]

(8) ETX (End of Text)

This control code indicates the end of a command string. The ASCII code is 03 in hexadecimal.

(9) CR (Carriage Return)

This control code indicates the end of a command. The ASCII code is 0D in hexadecimal.

 **NOTE**

The control codes “STX”, “ETX”, and “CR” are essential for commands when you create a communication program for PC link communication. Omission of any of them or incorrect order of them results in communication failure.

4.1.2 Configuration of Response

Responses from the PR300 with respect to a command sent from the higher-level device consist of the elements shown below, which differ depending on the condition of communication; normal or failure.

1) Normal Communication

When communication completes normally, the PR300 returns a character string “OK” and data corresponding to a command.

No parameter data area for write command.

Number of Bytes	1	2	2	2	Variable length	2	1	1
Element	STX	Station number (ST-NO)	CPU number 01	OK	Parameter data	Checksum	ETX	CR

2) In the Event of Failure

If communication does not complete normally, the PR300 returns a character string “ER” and error code (EC1 and EC2). (See subsection 4.1.3, “Response Error Codes”.)

- No response is made in case of an error in station number specification or CPU number specification.
- If a PR300 cannot receive ETX in a command, response may not be made.

Note: As a countermeasure, provide a timeout process in the communication functions of the higher-level device or in communication programs.

Number of Bytes	1	2	2	2	2	2	3	2	1	1
Element	STX	Station number (ST-NO)	CPU number 01	ER	EC1	EC2	Command	Checksum	ETX	CR

4.1.3 Response Error Codes

See Also

4.1.2, "Configuration of Response", for the configuration of response in the event of error.

The error codes (EC1) and detailed error codes (EC2) of responses are as follows.

Table 4.1 List of Error Codes EC1

Error Code	Meaning	Cause(s)
02	Command error	<ul style="list-style-type: none"> No command exists. Command not executable
03	Register specification error	<ul style="list-style-type: none"> No register number exists.
04	Out of setpoint range (when in writing operation)	<ul style="list-style-type: none"> A value other than hexadecimal values (0 to 9, A to F) has been specified in word specification. The position of a start for a data load/save or other command is out of the address range.
05	Out of data count range	<ul style="list-style-type: none"> The specification of the number of words is out of the specified range.
06	Monitor error	<ul style="list-style-type: none"> An attempt was made to execute monitoring without specifying the monitor (WRS).
08	Parameter error	<ul style="list-style-type: none"> An illegal parameter is set.
42	Checksum error	<ul style="list-style-type: none"> The sum does not match the expected value.
43	Internal buffer overflow	<ul style="list-style-type: none"> A data value greater than the specified was received.
44	Character reception timeout	<ul style="list-style-type: none"> The end-of-data or end-of-text character has not been received.

Table 4.2 List of Detailed Error Codes EC2

Error Code (EC1)	Meaning	Detailed Error Code (EC2)
03	Register specification error	Parameter number where error occurred (HEX) This is the sequence number of a parameter that first resulted in an error when counted from the leading parameter. e.g.: <div style="text-align: center; margin-left: 100px;"> Register name specification error ↓ [STX]01010WRW02D0043,3F80,A0044,0000[ETX][CR] Parameter numbers 1 2 3 4 5 </div> [STX]0101ER0304WRW[ETX][CR] In this case, EC1=03 and EC2=04.
04	Out of setpoint range	
05	Out of data count range	
08	Parameter error	

For error codes other than those noted as EC1, there is no EC2 meaning, and 0x00 is returned as a response.

4.1.4 Specifying Broadcast

The corresponding multiple PR300 perform the function to receive and process a command in which this station number is specified.

- (1) Specify "P1" for the station number in the command to execute it.
- (2) This command works independently of station numbers of slave stations (01 to 99).
- (3) This command is applicable for writing only.
- (4) No response is returned from the PR300 when communication is performed using this command.

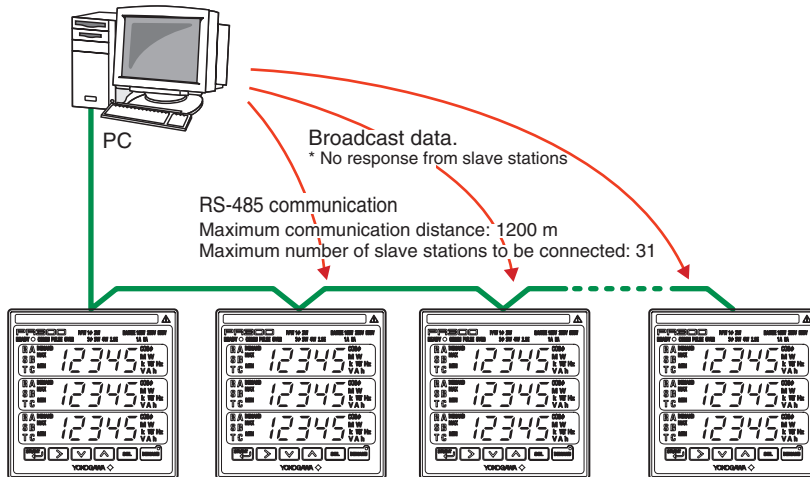

Figure 4.2 Broadcasting

[Example of Starting Optional Integrations]

Use PC link communication (without checksum) and the random write command as shown below:

```
[STX]P1010WRW01D0302,0000[ETX][CR]
```

D Register	Reference No.	H No.	Description	Effective Range
D0302	40302	012D	Optional integration start/stop (D0011 to D0014)	0: Stop 1: Start

4.2 Command and Response

The following shows the lists of commands available in PC link communication. The details of them are explained in the description of each command.

(1) Word-basis Access Commands

Command	Description	Number of words to be handled
WRD	Word-basis read	1 to 64 words
WWR	Word-basis write	1 to 64 words
WRR	Word-basis, random read	1 to 32 words
WRW	Word-basis, random write	1 to 32 words
WRS	Specifies D registers to be monitored on a word-by-word basis.	1 to 32 words
WRM	Word-basis monitoring	—

(2) Information Commands

Command	Description	Number of units to be handled
INF6	Reads model, suffix codes, and version.	1
INF7	Reads the maximum value of CPU.	1

WRD Reads D registers on a word-by-word basis

● Function

This function code reads a sequence of contiguous register information on a word-by-word basis by the specified number of words, starting with a specified register number.

- The number of words to be read at a time is 1 to 64.
- For the format of response in the event of failure, see subsection 4.1.2.
- The command shown below includes the checksum function. When performing communication without the checksum, do not include the 2-byte checksum element in the command.

● Command/Response (for normal operation)

Number of Bytes	1	2	2	1	3	5	1	2	2	1	1
Command element	STX	Station number (ST-NO)	01	0	WRD	Register number	Comma or space	Number of words (n)	Checksum	ETX	CR

Number of Bytes	1	2	2	2	4	4	...	4	2	1	1
Response element	STX	Station number (ST-NO)	01	OK	dddd1	dddd2	...	ddddn	Checksum	ETX	CR

The response is returned in a 4-digit character string (0000 to FFFF) in hexadecimal.

ddddn: read data of the specified number of words
 ddddn = character string in hexadecimal
 n = 1 to 64 words

● Example

Read the active energy (register symbol: kWh L and kWh H) of the PR300 at station number 01.

The register numbers for active energy are D0001 and D0002.

[Command]

[STX]01010WRDD0001, 0272 [ETX] [CR]

The data of active energy (2 words) will be returned in response to the command above.

[Response]

[STX]0101OK7840017D0B [ETX] [CR]

↑
25000000 [kWh] in decimal.
See the Note below.

Note: To use the response data as the reading, reverse the order of the upper and lower words.

Hex 7840 017D → (reversed) → Hex 017D 7840 → Decimal 25000000

WWR Writes data into D registers on a word-by-word basis

● Function

This function code writes information into a sequence of contiguous registers on a word-by-word basis by the specified number of words, starting with a specified register number.

- The number of words to be written at a time is 1 to 64.
- For the format of response in the event of failure, see subsection 4.1.2.
- The command shown below includes the checksum function. When performing communication without the checksum, do not include the 2-byte checksum element in the command.

● Command/Response (for normal operation)

Number of Bytes	1	2	2	1	3	5	1	2	1	4
Command element	STX	Station number (ST-NO)	01	0	WWR	Register number	Comma or space	Number of words (n)	Comma or space	dddd1

Command (continued)

4	...	4	2	1	1
dddd2	...	ddddn	Checksum	ETX	CR

Write information is specified in a 4-digit character string (0000 to FFFF) in hexadecimal.

(ddddn: write data of the specified number of words
 ddddn = character string in hexadecimal
 n = 1 to 64 words)

Number of Bytes	1	2	2	2	2	1	1
Response element	STX	Station number (ST-NO)	01	OK	Checksum	ETX	CR

● Example

Write the floating point data "00004120" into the VT ratio (register symbol: VT L and VT H) and CT ratio (register symbol: CT L and CT H) of the PR300 at station number 01.

The register numbers for VT ratio are D0201 and D0202.

The register numbers for CT ratio are D0203 and D0204.

[Command]

[STX]01010WWRD0201,04,0000412000004120C3[ETX][CR]

"OK" will be returned in response to the command above.

[Response]

[STX]0101OK5C[ETX][CR]

Note: To use the response data as the reading, reverse the order of the upper and lower words.

VT ratio: 4-byte floating-point hex data 0000 4120 → (reversed) → Hex 4120 0000 ⇒ Decimal 10

CT ratio: 4-byte floating-point hex data 0000 4120 → (reversed) → Hex 4120 0000 ⇒ Decimal 10

WRR Reads D registers on a word-by-word basis in random order

● Function

This function code reads the statuses of the individual registers, on a word-by-word basis, specified in a random order by the specified number of words.

- The number of words to be read at a time is 1 to 32.
- For the format of response in the event of failure, see subsection 4.1.2.
- The command shown below includes the checksum function. When performing communication without the checksum, do not include the 2-byte checksum element in the command.

● Command/Response (for normal operation)

Number of Bytes	1	2	2	1	3	2	5	1	5	1
Command element	STX	Station number (ST-NO)	01	0	WRR	Number of words (n)	Register number 1	Comma or space	Register number 2	Comma or space

Command (continued)

...	5	2	1	1
...	Register number n	Checksum	ETX	CR

Number of Bytes	1	2	2	2	4	4	...	4	2	1	1
Response element	STX	Station number (ST-NO)	01	OK	dddd1	dddd2	...	ddddn	Checksum	ETX	CR

The response is returned in a 4-digit character string (0000 to FFFF) in hexadecimal.

(dddd_n: read data of the specified number of words
 dddd_n = character string in hexadecimal
 n = 1 to 32 words)

● Example

Read the voltage-1 (register symbol: V1 L and V1 H) and current-1 (register symbol: A1 L and A1 H) of the PR300 at station number 01.

The register numbers for voltage-1 are D0027 and D0028.

The register numbers for current-1 are D0033 and D0034.

[Command]

[STX]01010WRR04D0027,D0028,D0033,D003405[ETX][CR]

The data 800V for the voltage-1 and 50A for the current-1 will be returned in response to the command above.

[Response]

[STX]0101OK000044480000424882[ETX][CR]

↑
 — 800 [V] and 50 [A] in decimal. See the Note below.

Note: To use the response data as the reading, reverse the order of the upper and lower words.

Voltage-1: floating-point hex data 0000 4448 → (reversed) → Hex 4448 0000 ⇒ Decimal 800

Current-1: floating-point hex data 0000 4248 → (reversed) → Hex 4248 0000 ⇒ Decimal 50

WRW Writes data into D registers on a word-by-word basis in random order

● Function

This function code writes register information specified for each register into the registers specified in a random order by the specified number of words.

- The number of words to be written at a time is 1 to 32.
- For the format of response in the event of failure, see subsection 4.1.2.
- The command shown below includes the checksum function. When performing communication without the checksum, do not include the 2-byte checksum element in the command.

● Command/Response (for normal operation)

Number of Bytes	1	2	2	1	3	2	5	1	4	1
Command element	STX	Station number (ST-NO)	01	0	WRW	Number of words (n)	Register number 1	Comma or space	dddd1	Comma or space

Command (continued)

5	1	4	...	5	1	4	2	1	1
Register number 2	Comma or space	dddd2	...	Register number n	Comma or space	ddddn	Checksum	ETX	CR

Write information is specified in a 4-digit character string (0000 to FFFF) in hexadecimal.

ddddn: repetition of register numbers and write information of the specified number of words
 ddddn = character string in hexadecimal
 n = 1 to 32 words

Number of Bytes	1	2	2	2	2	1	1
Response element	STX	Station number (ST-NO)	01	OK	Checksum	ETX	CR

● Example

Write 1 into the remote reset (register symbol: RMT RST) and active energy reset (register symbol: kWh RST) of the PR300 at station number 01.

The register number for remote reset is D0400.

The register number for active energy reset is D0353.

[Command]

[STX]01010WRW02D0400,0001,D0353,000171[ETX][CR]

“OK” will be returned in response to the command above.

[Response]

[STX]0101OK5C[ETX][CR]

WRS Specifies the D registers to be monitored on a word-by-word basis

● Function

This function code specifies the register numbers to be monitored on a word-by-word basis. Note that this command simply specifies the registers. Actual monitoring is performed by the WRM command after the register numbers are specified by this command.

If the volume of data is large and you wish to increase the communication rate, it is effective to use a combination of the WRS and WRM commands rather than the WRR command. If the power supply is turned off, the register numbers specified will be erased.

- The number of words to be specified at a time is 1 to 32.
- For the format of response in the event of failure, see subsection 4.1.2.
- The command shown below includes the checksum function. When performing communication without the checksum, do not include the 2-byte checksum element in the command.

● Command/Response (for normal operation)

Number of Bytes	1	2	2	1	3	2	5	1	5	1
Command element	STX	Station number (ST-NO)	01	0	WRS	Number of words (n)	Register number 1	Comma or space	Register number 2	Comma or space

Command (continued)

...	5	2	1	1
...	Register number n	Checksum	ETX	CR

Number of Bytes	1	2	2	2	2	1	1
Response element	STX	Station number (ST-NO)	01	OK	Checksum	ETX	CR

● Example

Specify that the active power (register symbol: W L and W H) of the PR300 at station number 01 is to be monitored. (This command simply specifies the registers.) The register numbers for active power are D0021 and D0022.

[Command]

[STX]01010WRS02D0021,D00228B[ETX][CR]

“OK” will be returned in response to the command above.

[Response]

[STX]0101OK5C[ETX][CR]

WRM Monitors the D registers on a word-by-word basis

● Function

This function code reads the information of the registers that have been specified in advance by the WRS command.

- Before executing this command, the WRS command must always be executed to specify which registers are to be monitored. If no register has been specified, error code 06 is returned.
- For the format of response in the event of failure, see subsection 4.1.2.
- The command shown below includes the checksum function. When performing communication without the checksum, do not include the 2-byte checksum element in the command.

● Command/Response (for normal operation)

Number of Bytes	1	2	2	1	3	2	1	1
Command element	STX	Station number (ST-NO)	01	0	WRM	Checksum	ETX	CR

Number of Bytes	1	2	2	2	4	4	...	4	2	1	1
Response element	STX	Station number (ST-NO)	01	OK	dddd1	dddd2	...	ddddn	Checksum	ETX	CR

The response is returned in a 4-digit character string (0000 to FFFF) in hexadecimal.

{

 ddddn: read data of the number of words specified by the WRS command
 ddddn = character string in hexadecimal
 n = 1 to 32 words

}

● Example

Monitor the active power (register symbol: W L and W H) of the PR300 at station number 01. (This command reads the status of the register specified by the WRS command.)

[Command]

[STX]01010WRME8[ETX][CR]

The data 2500 will be returned in response to the command above.

[Response]

[STX]0101OK4000451CF9[ETX][CR]

Note: To use the response data as the reading, reverse the order of the upper and lower words.

Active power: floating-point hex data 4000 451C → (reversed) → Hex 451C 4000 ⇒ Decimal 2500

INF6 Reads the model, suffix codes, and version information

● Function

This function code reads the model, suffix codes, and version number of the PR300.

- For the format of response in the event of failure, see subsection 4.1.2.

● Command/Response (for normal operation)

Number of Bytes	1	2	2	1	3	1	2	1	1
Command element	STX	Station number (ST-NO)	01	0	INF	6	Checksum	ETX	CR

Number of Bytes	1	2	2	2	12	4	4	4
Response element	STX	Station number (ST-NO)	01	OK	Model code: PR300☆★□□□□□□ (Note 1)	Version and revision numbers (Note 2)	Start register specified for readout refreshing* 1	Number of registers specified for readout refreshing* 22

Response (continued)

4	4	2	1	1
Start register specified for write refreshing* 1	Number of registers specified for write refreshing* 0	Checksum	ETX	CR

The * mark indicates fields the FA-M3's UT link module refers to.

Note 1: Model and suffix code information

PR300-☆★□□□-□□

<Model>-<Suffix code>

☆: Returns the currently selected phase and wire system

- 1: Single-phase two-wire system
- 2: Single-phase three-wire system
- 3: Three-phase three-wire system
- 4: Three-phase four-wire system
- 5: Three-phase four-wire system (2.5 element)

★: Returns the currently selected input range

- 1: 150 V/1 A
- 2: 150 V/5 A
- 3: 300 V/1 A
- 4: 300 V/5 A
- 5: 600 V/1 A
- 6: 600 V/5 A

(* ★ and ☆ are decided by the settings of the phase and wire system and the input range.)

□: Returns the suffix code as is

Example:

Suffix code: PR300-32333-6A-0; _____ Not returned
 Selected phase and wire system: _____ Single-phase three-wire system; and
 Selected input range: 300 V/5 A; then
 PR300243336A

Note 2: Version number and revision number

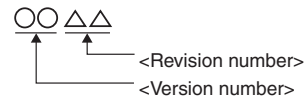

Example: 0102
 (version number + revision number)

● Example

To read the model, suffix code etc. of PR300 at station number 01:

[Command]

[STX]01010INF605[ETX][CR]

In response to this command, the following values will be returned:

Phase and wire system: Single-phase three-wire system

Rated input voltage/current: 300 V/5 AAC

I/O function: Analog output and pulse output

Communication function: Ethernet

Optional measuring function: Demand measurement

Phase indication format: R, S, and T indications

[Response]

[STX]01010KPR300243336R01020001002200010000E1[ETX][CR]

INF7 Reads the maximum value of CPU

● Function

This function code returns the maximum value of CPU of a station in PC link communication.

- For the format of response in the event of failure, see subsection 4.1.2.

● Command/Response (for normal operation)

Number of Bytes	1	2	2	1	3	1	2	1	1
Command element	STX	Station number (ST-NO)	01	0	INF	7	Checksum	ETX	CR

Number of Bytes	1	2	2	2	1	2	1	1
Response element	STX	Station number (ST-NO)	01	OK	CPU maximum value (Note1)	Checksum	ETX	CR

Note 1: The maximum value of CPU for power and energy meter is 1.

● Example

Read the maximum value of CPU number of the PR300 at station number 01.

[Command]

[STX]01010INF706[ETX][CR]

The data 1 will be returned in response to the command above.

[Response]

[STX]0101OK18D[ETX][CR]

4.3 Communication with Higher-level Devices

Higher-level devices are those capable of using the PC link communication protocol.

4.3.1 Communication with FA-M3 (UT Link Module)

Communication with FA-M3 is achieved by simply connecting the PR300 to a UT link module using the PC link communication protocol. Set the communication conditions of the PR300 identical to those of the UT link module.

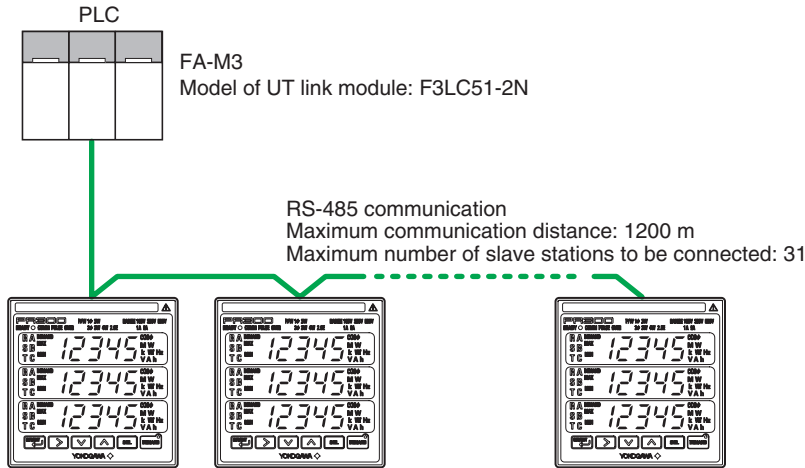

Figure 4.3 Communication with UT Link Module

The UT link module function has the following two modes, which allow you to communicate with FA-M3 without being aware of it. For more information, see the optionally available user's manual of UT Link Module (IM 34M6H25-01E).

1. Automatic mode

This mode enables the instruments' fixed devices (those that cannot be specified by the user) to be constantly refreshed by reading from them. The fixed devices are D0001 to D0022, and the read areas cannot be written to.

2. Manual mode

This mode enables the instrument's devices (those that can be specified by the user) to be constantly refreshed by reading from and/or writing to them.

See Also

The devices mentioned here are D registers. For more information on D registers, see Chapter 7.

FA-M3's UT Link Module Setup Procedure (Example)

This section explains the procedure for setting up the FA-M3's UT link module when the "Automatic mode" is used.

(1) Setting Up the UT Link Module

Before following the procedure, always make sure that the FA-M3's UT link module is turned off. Then, open the inner cover and follow the setup steps described below.

Configure the DIP switch of the UT link module as shown below:

Switch No.	Status	Description
SW1	ON	Data length: 8 bits
SW2, SW3	ON	Parity: none (initial value: even)
SW4	OFF	Stop bit: 1 bit
SW5	OFF	Checksum: none
SW6	ON	Termination character: yes (CR)
SW7	ON	Mode: Automatic mode
SW8	OFF	Not used.

Set the Baud Rate switch to 9600 bps.

Set the Communication Mode switch to 7 (Normal).

(2) Setting Up the PR300

Set the communication conditions of the PR300 as shown below:

For details on how to set the conditions, see the PR300 Power and Energy Meter User's Manual (electronic manual).

Parameter	Description
Communication protocol	PC link communication (without checksum)
Data length	8 bits
Parity	None
Stop bit	1 bit
Baud rate	9600 bps

(3) Turn on the FA-M3.

4.4 Sample Program

4.4.1 Example of BASIC Program for Send and Receive

This section shows an example of a command sending and response receiving program created with F-BASIC*2 for PC/AT*1 (or compatible machines).

*1 PC/AT is the product of IBM Ltd.

*2 F-BASIC is the product of Fujitsu Ltd.

Example of the Program Created Using F-BASIC Version 6.3

Communication Conditions	Baud rate:	9600bps	
	Parity:	None	
	Data length:	8 bits	
	Stop bit:	1 bit	
	Protocol:	PC link (without checksum)	

```

STX$=CHR$(2)           `Define
ETX$=CHR$(3)           `Define
CR$=CHR$(13)           `Define
LF$=chr$(10)           `Define
RCVCHR$=""             `Initialize receive character string
STOPFLAG=0             `Initialize end flag
`
SEND$=STX$+"01010WRDD0001,02"+ETX$ `Create character string for send
`
BAUD 0,9600             `Set a communication baud rate
open "COM0:(F8N1N7)" as #1 `Open a communication port
`
    interval 5           `Set timeout timer
    on com(0) gosub *RECEIVECHR `Specify interruption processing
                                during receiving
    on interval gosub *TIMEOUT `Specify interruption processing
                                at timeout
`
    print #1,SEND$       `Send
    com(0) on            `Permit interruption during receiving
    interval on          `Start timer
`
    while STOPFLAG=0    `Wait for receive end or timeout
    waiti
    wend
`
    com(0) off           `Permit interruption during receiving
    close #1             `Close the port
`
    print ">" +SEND$     `Display sent character string
                                on screen
    print "<" +RCVCHR$   `Display received character
                                string on screen

end
`

```

```
`=== Subroutine ===
*RECEIVECHR                                `Interruption processing during
                                           receiving
    interval off                            `Start timer
    RCVCHR$=RCVCHR$+input$(lof(#1),#1)      `Fetch character string
                                           from receive buffer.
    END$=mid$(RCVCHR$,len(RCVCHR$),1)
    select case END$
        case LF$                            `Echo-back-capable
            RCVCHR$=""                       `Initialize receive character string
        case CR$                            `Receiving end flag
            STOPFLAG=1                       `Set receiving end flag
        case else
    end select
    interval on                              `Start timer
return
`
*TIMEOUT                                    `Timeout processing
    STOPFLAG=1                              `Set timeout flag
    RCVCHR$="Time out ! (5 sec)" + CR$
                                           `Character string for display
                                           on screen "Time out ! (5 sec)"
return
```

5. Modbus/RTU and ASCII Communication Protocols

5.1 Overview

The use of Modbus communication enables the PR300 to communicate with a device such as a PC or PLC (sequencer). Such a device can be used in communication to read/write data from/to D registers which are internal registers of the PR300.

Hereafter, PCs are generically called “higher-level devices.”

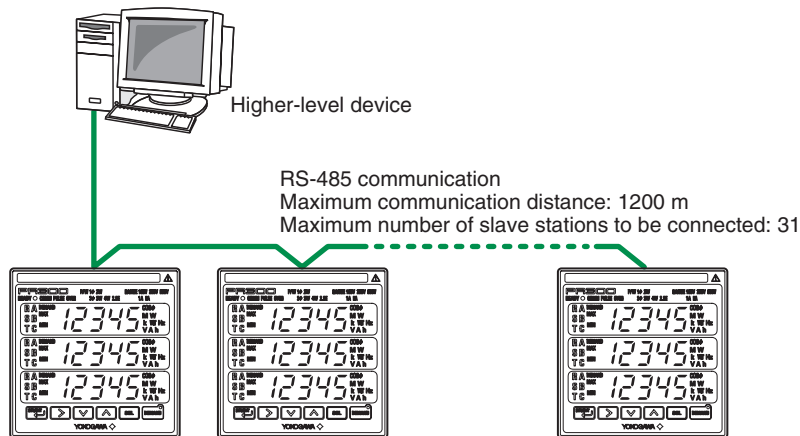

Figure 5.1 Example of Connection for Modbus Communication

See Also

Chapter 7 for information on the D registers.

For Modbus communication with the PR300, we provide the ASCII mode and RTU mode (binary system) for the transmission mode.

Table 5.1 ASCII and RTU Modes

Item	ASCII Mode	RTU Mode
Number of data bits	7 bits (ASCII)	8 bits (binary)
Message start mark	: (colon)	None
Message end mark	CR+LF (*2)	None
Message length (*1)	2N+1	N
Data time intervals	1 second or less	Between frames: 3.5 characters
Error detection	Longitudinal redundancy check: LRC	Cyclic redundancy check: CRC-16

*1: When message length in the RTU mode is assumed to be "N", message length in ASCII mode is "2N+1".
 *2: LF is a synchronization character indicating that the PR300 is ready to accept the next signal. In the RTU mode, synchronization is achieved during the time interval between characters. If there is a period of time equivalent to 3.5 characters before the next character is received, the message being received next is recognized as a new frame.

In Modbus communication, a higher-level device identifies each PR300 with a station number of 01 to 99.

 **NOTE**

- The PR300 has data (D register) the unit of which is two words. When 2-word data need to be written or read, writing or reading operations must be performed for the 2-word data at the same time.
- Even if data written to the D register is out of the effective range, a normal response is returned.

5.1.1 Configuration of Message

Messages sent from the higher-level device to the PR300 consist of the following elements.

Element	Start of Message Mark	Station Number (ST-NO)	Function Code	Data	Error Check	End of Message Mark
Number of bytes in RTU mode	None	1	1	2n (variable)	2	None
Number of bytes in ASCII mode	1	2	2	4n (variable)	2	2

(1) (2) (3) (4) (5) (6)

(1) Start of Message Mark

This mark indicates the start of a message. Note that only ASCII mode requires a colon (:).

(2) Station Number (01 to 99)

Station numbers are used by the higher-level device to identify the PR300 at the communication destination. (These numbers are identification numbers specific to individual PR300, which are expressed in hexadecimal in the message.)

00: Broadcasting mode (See subsection 5.1.5, "Specifying Broadcast")

(3) Function Code (See section 5.2, "Message and Response")

This element specifies a command (function code) from the higher-level device.

(4) Data

This element specifies D register numbers, the number of D registers, parameter values, or others in accordance with the function code. (It is expressed in hexadecimal in the message.)

(5) Error Check

In RTU mode: Carried out by the cyclic redundancy check (CRC-16) system.

In ASCII mode: Carried out by the longitudinal redundancy check (LRC) system.

(6) End of Message Mark

This mark indicates the end of a message. Note that only ASCII mode requires CR + LF.

5.1.2 Specifying D Registers

Specification of D registers using commercially available SCADA or other software and specification of D registers for messages used in a customer-created communication program are different. Take note of this.

For a customer-created communication program, specify a value in hexadecimal that is obtained by subtracting 40001 from a reference number.

Example: Specifying “D0043”

For messages in the customer-created communication program, specify “002A,” the hexadecimal number of value 42 obtained by subtracting 40001 from the reference number.

5.1.3 Checking Errors

Modbus communication has two modes, i.e., the ASCII mode which is communication based on ASCII characters and the RTU mode which is binary code communication. These modes use different error-checking methods.

■ ASCII Mode

In the ASCII mode, errors are checked by means of an LRC longitudinal redundancy check.

The LRC value is the two's complement of the sum obtained by adding up data byte by byte, from the station number to the last data item, excluding ‘:’, ‘CR’ and ‘LF.’ Ignore the carry that may occur at the upper digit when adding up the data.

Example:

The method of calculating the LRC for the [:]110300C80004[LRC][CR][LF] command for reading a series of four D registers of the device at station number 17, starting with the D00201 (VT ratio) register, is as follows:

- [1] Station number 17 is 11 in hexadecimal.
Change the data to byte-by-byte hex data \Rightarrow 11,03,00,C8,00,04.
(In the Modbus/ASCII message, this data is represented by the ASCII code as two bytes, i.e., 31 and 31 in hexadecimal.)
- [2] Add up the byte-by-byte hex data on a byte-by-byte basis.
 $\Rightarrow 11 + 03 + 00 + C8 + 00 + 04 = E0$
- [3] Find the two's complement of the lower one byte of the data thus added up \Rightarrow 20
 $11100000 (0xE0) \rightarrow 00011111 (\text{complement}) + 1 = 00100000 (20)$

■ RTU Mode

In the RTU mode, errors are checked by means of a CRC-16 cyclic redundancy check. The CRC-16 value is the 16-bit remainder when the value obtained by concatenating the 8 bits of all blocks (from the station number to the last data item) of a message, excluding the start bit, stop bit and parity bit, is divided by a predetermined 17-bit binary number.

● Example of CRC-16 Calculation

When executing function code 03 (reads data from multiple D registers) to read the status from the slave at station number 11 "0B", send the 0B03002A0004 command.

- [1] The initial value is FFFF. Find the XOR value of this initial value and the first character (= station number 11).
- [2] Refer to the lower byte of the result of executing the function code (or the upper byte, if the result is regarded as a block of text). From the table, obtain the value corresponding to that byte. Since the result is "F4" in this example, you refer to the 244th value in the table and obtain "8701".
- [3] Find the XOR value of the upper byte of the XOR operation in step [1] and the result of step [2]. This value is the first character of the CRC-16 calculation.
- [4] Using the result of step [3] (remainder) as the next initial value, make the same calculation to evaluate the second character (function code 03).

Initial value	FF FF	
Station number	0B	
XOR	-----	
Reference to table	FF F4	← Convert the hex value to a decimal value, find the corresponding number in Table 5.2, and substitute the number into the formula.
XOR	87 01	← In the example shown on the left, hex value "F4" is converted to decimal value 244. From Table 5.2, the number corresponding to 244 proves to be "8701". This number is substituted into the formula.
XOR	-----	
Function code	87 FE	
Function code	03	
XOR	-----	
Reference to table	87 FD	
XOR	81 C1	
XOR	-----	
XOR	81 46	
•	•	
•	•	
•	•	
XOR	E5 9E	
Last character	04	
XOR	-----	
Reference to table	E5 9A	
XOR	6B 80	
Resulting error	-----	
Resulting error	6B 65	

- [5] Repeat steps [1] to [4] to perform the calculation up to the last character string 04.
- [6] Reverse the order of the upper and lower bytes of 6B65 and append 656B to the end of the character string as the error code.
0B03002A0004656B

First reverse the order of the upper and lower bytes of the calculated result, then compare the value with the received data or store the value in the transmission buffer.

* Numbers in quotation marks are hexadecimal.

Table 5.2 Results of Performing CRC on 0th to 255th Values at “A001”

Number	0	1	2	3	4	5	6	7
Result	0000	C0C1	C181	0140	C301	03C0	0280	C241
Number	8	9	10	11	12	13	14	15
Result	C601	06C0	0780	C741	0500	C5C1	C481	0440
Number	16	17	18	19	20	21	22	23
Result	CC01	0CC0	0D80	CD41	0F00	CFC1	CE81	0E40
Number	24	25	26	27	28	29	30	31
Result	0A00	CAC1	CB81	0B40	C901	09C0	0880	C841
Number	32	33	34	35	36	37	38	39
Result	D801	18C0	1980	D941	1B00	DBC1	DA81	1A40
Number	40	41	42	43	44	45	46	47
Result	1E00	DEC1	DF81	1F40	DD01	1DC0	1C80	DC41
Number	48	49	50	51	52	53	54	55
Result	1400	D4C1	D581	1540	D701	17C0	1680	D641
Number	56	57	58	59	60	61	62	63
Result	D201	12C0	1380	D341	1100	D1C1	D081	1040
Number	64	65	66	67	68	69	70	71
Result	F001	30C0	3180	F141	3300	F3C1	F281	3240
Number	72	73	74	75	76	77	78	79
Result	3600	F6C1	F781	3740	F501	35C0	3480	F441
Number	80	81	82	83	84	85	86	87
Result	3C00	FCC1	FD81	3D40	FF01	3FC0	3E80	FE41
Number	88	89	90	91	92	93	94	95
Result	FA01	3AC0	3B80	FB41	3900	F9C1	F881	3840
Number	96	97	98	99	100	101	102	103
Result	2800	E8C1	E981	2940	EB01	2BC0	2A80	EA41
Number	104	105	106	107	108	109	110	111
Result	EE01	2EC0	2F80	EF41	2D00	EDC1	EC81	2C40
Number	112	113	114	115	116	117	118	119
Result	E401	24C0	2580	E541	2700	E7C1	E681	2640
Number	120	121	122	123	124	125	126	127
Result	2200	E2C1	E381	2340	E101	21C0	2080	E041
Number	128	129	130	131	132	133	134	135
Result	A001	60C0	6180	A141	6300	A3C1	A281	6240
Number	136	137	138	139	140	141	142	143
Result	6600	A6C1	A781	6740	A501	65C0	6480	A441
Number	144	145	146	147	148	149	150	151
Result	6C00	ACC1	AD81	6D40	AF01	6FC0	6E80	AE41
Number	152	153	154	155	156	157	158	159
Result	AA01	6AC0	6B80	AB41	6900	A9C1	A881	6840
Number	160	161	162	163	164	165	166	167
Result	7800	B8C1	B981	7940	BB01	7BC0	7A80	BA41
Number	168	169	170	171	172	173	174	175
Result	BE01	7EC0	7F80	BF41	7D00	BDC1	BC81	7C40
Number	176	177	178	179	180	181	182	183
Result	B401	74C0	7580	B541	7700	B7C1	B681	7640
Number	184	185	186	187	188	189	190	191
Result	7200	B2C1	B381	7340	B101	71C0	7080	B041
Number	192	193	194	195	196	197	198	199
Result	5000	90C1	9181	5140	9301	53C0	5280	9241
Number	200	201	202	203	204	205	206	207
Result	9601	56C0	5780	9741	5500	95C1	9481	5440
Number	208	209	210	211	212	213	214	215
Result	9C01	5CC0	5D80	9D41	5F00	9FC1	9E81	5E40
Number	216	217	218	219	220	221	222	223
Result	5A00	9AC1	9B81	5B40	9901	59C0	5880	9841
Number	224	225	226	227	228	229	230	231
Result	8801	48C0	4980	8941	4B00	8BC1	8A81	4A40
Number	232	233	234	235	236	237	238	239
Result	4E00	8EC1	8F81	4F40	8D01	4DC0	4C80	8C41
Number	240	241	242	243	244	245	246	247
Result	4400	84C1	8581	4540	8701	47C0	4680	8641
Number	248	249	250	251	252	253	254	255
Result	8201	42C0	4380	8341	4100	81C1	8081	4040

5.1.4 Configuration of Response

The PR300 receives a command message from the higher-level device. If the received command message is found to be normal and directed at the station number of the PR300 itself, the PR300 concludes the content of the message to be normal. Thus, the PR300 enters the phase of executing message processing, deciphers the content of the command message, and processes with the message.

The PR300 does not execute message processing, however, if the received command message is found to be abnormal. In that case, the PR300 either ignores the received message or creates a response message telling the received message is erroneous.

After receiving a normal command message and executing a given process, the PR300 creates and sends a response message to which error check data appropriate for the command function code of the higher-level device is added.

■ Responses to Normal Messages

For a loop back function or a function for writing to a single register, the PR300 returns the received command message as a response message.

For a function for writing to multiple D registers, the PR300 returns part of the received command message as the response message.

For a readout function, the PR300 adds the read data to the ends of the station number and function code of the received command message, and returns the message as the response message.

■ Responses to Abnormal Messages

If there is any failure other than transmission errors, the PR300 returns the following response message without executing any process:

Element	Start of Message Mark (:)	Station Number (ST-NO)	Function Code (*1)	Error Code	Error Check	[CR][LF]
Number of bytes in RTU mode	None	1	1	1	2	None
Number of bytes in ASCII mode	1	2	2	2	2	2

*1: The function code entered here is the function code (in hex) plus 80 (in hex).

The following table summarizes details on the error codes.

Error Code	Meaning	Cause
01	Function code error	Function code does not exist.
02	Abnormal D register number	D register number out of the range is specified.
03	Abnormal number of D registers	Number of D registers out of the range is specified.

The PR300 does not regard it as an error even if there is any unused register among those with consecutive register numbers specified by a readout function; rather, the PR300 returns a value of 0 in this case.

The PR300 returns the error code 02 or 03 if the specified consecutive registers are made to fall outside the given range by the number of registers specified, even though the D-register start number was initially within the range. (Depend on the function code.)

■ Cases when There Are No Responses to Transmitted Messages

- A transmission error (overrun, framing, parity, LRC or CRC-16 error) is encountered.
- The station number in the command message is wrong.
- The interval between data composing a message is longer than 2 seconds.
- The station number is "00" (broadcast specification).
- The receiving buffer has overflowed.

Note: As a measure against the abovementioned problems, add a time-out process to the communication function or program of the higher-level device.

5.1.5 Specifying Broadcast

The corresponding multiple PR300s perform the function to receive and process a command in which this station number is specified.

- (1) Specify "00" for the station number in the command to execute it.
- (2) This command works independently of station numbers of slave stations.
- (3) This command is applicable for writing only.
- (4) No response is returned from the PR300 when communication is performed using this command.

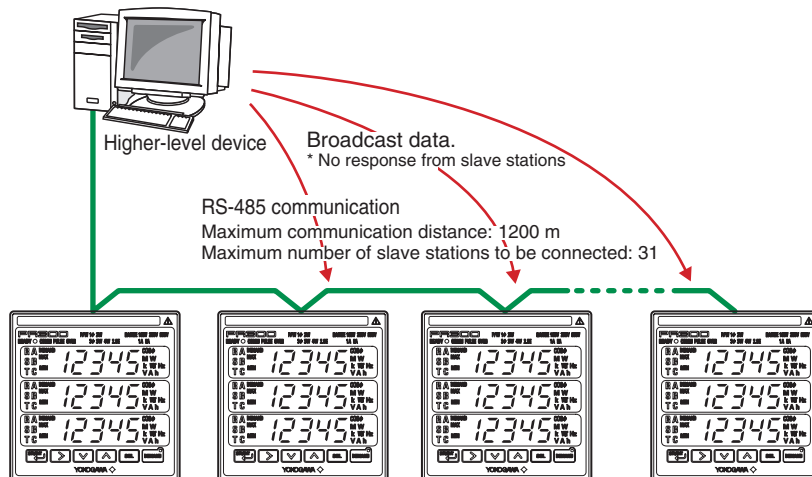

Figure 5.2 Broadcasting

[Example]

Write 0001 into the D0400 (remote reset) using broadcast command.

[Message]

```
[:]:0006018F000168[CR][LF]
```

"00": broadcast addressing, "06": function code 06,
 "018F": D register number 400, "0001": data 0001, "68": error check
 * Numbers in quotation marks are hexadecimal.

No response is returned to the above message.

D-Reg No.	Ref No.	H No.	Description	Effective Range
D0400	40400	018F	Remote reset	If other than 1: Invalid If 1: PR300 is reset

NOTE

- When remote reset is executed, maximum, minimum and instantaneous voltage values and maximum and instantaneous current values will be reset. Optional integration is terminated if it is being performed.
- Even when remote reset is executed, active energy, reactive energy, and apparent energy data as well as set parameter values are retained.

5.2 Message and Response

Function codes are command words used by the higher-level device to obtain the D registers information of PR300.

Table 5.3 Function Codes

Code	Function	Description
03	Reads data from multiple D registers.	Capable of reading data from a maximum of 64 successive D registers between D0001 and D0400.
06	Writes data into D register.	Capable of writing data into one D register between D0001 and D0400.
08	Performs loop back test.	Used when checking communication wiring.
16	Writes data into multiple D registers.	Capable of writing data into a maximum of 32 successive registers between D0001 and D0400.

- The write function codes cannot be written into read-only or user-prohibited D registers.
- Broadcast addressing is possible with function codes 06 and 16 only. (Also in this case, cannot be written into read-only or user-prohibited D registers.)

03 Reads data from multiple D registers

● Function

This function code reads the contents of successive D registers by the specified number starting with a specified D registers number.

- The maximum number of D registers to be read at a time is 64.
- For the format of responses in the event of failure, see subsection 5.1.4.

● Message (for normal operation)

Element	Start of Message Mark (:)	Station Number (ST-NO)	Function Code (03)	D-Register Start Number	Number of D Registers
Number of bytes in RTU mode	None	1	1	2	2
Number of bytes in ASCII mode	1	2	2	4	4

Message (continued)

Error Check	End of Message Mark (CR + LF)
2	None
2	2

● Response (for normal operation)

Element	Start of Message Mark (:)	Station Number (ST-NO)	Function Code (03)	Byte Count	Contents of D Register	...
Number of bytes in RTU mode	None	1	1	1	2	...
Number of bytes in ASCII mode	1	2	2	2	4	...

Response (continued)

Contents of D Register	Error Check	End of Message Mark (CR + LF)
2	2	None
4	2	2

● Example (ASCII mode)

Read a series of four D registers starting with the D0201 (VT ratio and CT ratio) at station number 11.

[Message] [:]0B0300C8000426[CR][LF]
 "0B":station number 11, "03": function code 03, "00C8": D register start number 201, "0004": number of D registers 4, and "26": error check

* Numbers in quotation marks are hexadecimal.

The following response will be returned to the message above.

[Response] [:]0B030800003F8000003F806C[CR][LF]

* The VT ratio and CT ratio data are floating point values. The combined value of D0201 and D0202, 00003F80, represents 1. That of D0203 and D0204, which is also 00003F80, represents 1 as well (the upper four digits, 3F80, and the lower four digits, 0000, are reversed).

* The floating point value of 3F800000 is the decimal equivalent of 1.

06 Writes data into D register

● Function

This function code writes data into a specified D registers number.

- The maximum number of D registers to be written into at a time is 1.
- For the format of response in the event of failure, see subsection 5.1.4.
- Broadcast addressing is possible (by setting “00” to the station number).

● Message (for normal operation)

Element	Start of Message Mark (:)	Station Number (ST-NO)	Function Code (06)	D-Register Number (Upper Digit)	D-Register Number (Lower Digit)
Number of bytes in RTU mode	None	1	1	1	1
Number of bytes in ASCII mode	1	2	2	2	2

Message (continued)

Write Data (Upper Digit)	Write Data (Lower Digit)	Error Check	End of Message Mark (CR + LF)
1	1	2	None
2	2	2	2

● Response (for normal operation)

Element	Start of Message Mark (:)	Station Number (ST-NO)	Function Code (06)	D-Register Number (Upper Digit)	D-Register Number (Lower Digit)
Number of bytes in RTU mode	None	1	1	1	1
Number of bytes in ASCII mode	1	2	2	2	2

Response (continued)

Write Data (Upper Digit)	Write Data (Lower Digit)	Error Check	End of Message Mark (CR + LF)
1	1	2	None
2	2	2	2

● Example (ASCII mode)

Write 0001 into the D0302 (optional integration start/stop) at station number 11.

[Message] [:]0B06012D0001C0[CR][LF]

“0B”: station number 11, “06”: function code 06, “012D”: D register number 302, “0001”: data 0001, and “C0”: error check

* Numbers in quotation marks are hexadecimal.

The following response will be returned to the message above.

[Response] [:]0B06012D0001C0[CR][LF]

The frame same as the message is returned.

08 Performs loop back test

● Function

This function code is used to check connection for communication.

- For the format of response in the event of failure, see subsection 5.1.4.
- The “00” shown below (marked with an asterisk *) are fixed.
- Any value can be selected for transmit data.

● Message (for normal operation)

Element	Start of Message Mark (:)	Station Number (ST-NO)	Function Code (08)	00* 0000	Transmit Data (Arbitrary)
Number of bytes in RTU mode	None	1	1	2	2
Number of bytes in ASCII mode	1	2	2	4	4

Message (continued)

Error Check	End of Message Mark (CR + LF)
2	None
2	2

● Response (for normal operation)

Element	Start of Message Mark (:)	Station Number (ST-NO)	Function Code (08)	00 0000	Same as Transmit Data
Number of bytes in RTU mode	None	1	1	2	2
Number of bytes in ASCII mode	1	2	2	4	4

Response (continued)

Error Check	End of Message Mark (CR + LF)
2	None
2	2

● Diagnostic Codes

Diagnostic Code	Meaning	Data
0000	Command message return	Arbitrary

● Example (ASCII mode)

Send data 0000 (fixed) and transmit data 04D2 (arbitrary) to the station number 11 to check the connection for communication.

[Message] [:]0B08000004D217[CR][LF]

When the connection is normal, the following response same as the command will be returned.

[Response] [:]0B08000004D217[CR][LF]

16 Writes data into multiple D registers

● Function

This function code writes data into successive D registers by the number starting with a specified D registers number.

- The maximum number of D registers to be written into at a time is 32.
- For the format of response in the event of failure, see subsection 5.1.4.
- Broadcast addressing is possible (by setting “00” to the station number). No response is returned when using the broadcast addressing.

● Message (for normal operation)

Element	Start of Message Mark (:)	Station Number (ST-NO)	Function Code (10)	D-Register Start Number (Upper Digit)	D-Register Start Number (Lower Digit)
Number of bytes in RTU mode	None	1	1	1	1
Number of bytes in ASCII mode	1	2	2	2	2

Message (continued)

Number of D Registers (Upper Digit)	Number of D Registers (Lower Digit)	Byte Count	Data (Upper Digit)	Data (Lower Digit)	...	Error Check	End of Message Mark (CR + LF)
1	1	1	1	1	...	2	None
2	2	2	2	2	...	2	2

● Response (for normal operation)

Element	Start of Message Mark (:)	Station Number (ST-NO)	Function Code (10)	D-Register Start Number (Upper Digit)	D-Register Start Number (Lower Digit)
Number of bytes in RTU mode	None	1	1	1	1
Number of bytes in ASCII mode	1	2	2	2	2

Response (continued)

Number of D Registers (Upper Digit)	Number of D Registers (Lower Digit)	Error Check	End of Message Mark (CR + LF)
1	1	2	None
2	2	2	2

● Example (ASCII mode)

Write 10 into a series of four D registers starting with the D0201 (VT ratio and CT ratio) at station number 11.

[Message] [:]0B1000C800004120000041204F[CR][LF]

“0B”: station number 11, “10”: function code 16, “00C8”: D register start number 201, “0004”: number of D registers 4, “08”: byte count (number of D registers × 2), “0000”: VT ratio lower two bytes, “4120”: VT ratio upper two bytes, “0000”: CT ratio lower two bytes, “4120”: CT ratio upper two bytes and “4F”: error check

* Numbers in quotation marks are hexadecimal.

The following response will be returned to the message above.

[Response]

[:]0B1000C8000419[CR][LF]

Write 1 into the D0207(setup change status) to activate the writing into the VT ratio and CT ratio.

[:]0B0600CE000120[CR][LF]

“0B”: station number 11, “06”: function code 06, “00CE”: D register start number 207, “0001”: writing data 0001, and “20”: error check

* Numbers in quotation marks are hexadecimal.

6. Modbus/TCP Communication Protocol

6.1 Overview

Modbus/TCP is one of the protocol used to communicate with devices such as PCs or PLCs (sequencers) using the TCP/IP protocol via Ethernet and other networks.

This communication protocol is used to perform read/write operations with the D registers in the PR300 and exchange data with connected devices.

The PR300 can be connected to IEEE802.3-compliant networks (10BASE-T/100BASE-TX). Generally, the Modbus/TCP protocol communicates through port 502.

In addition, the PR300 operates as Ethernet-serial gateway. A higher-level device can exchange data with other serial communication devices using the Modbus/TCP protocol via the PR300.

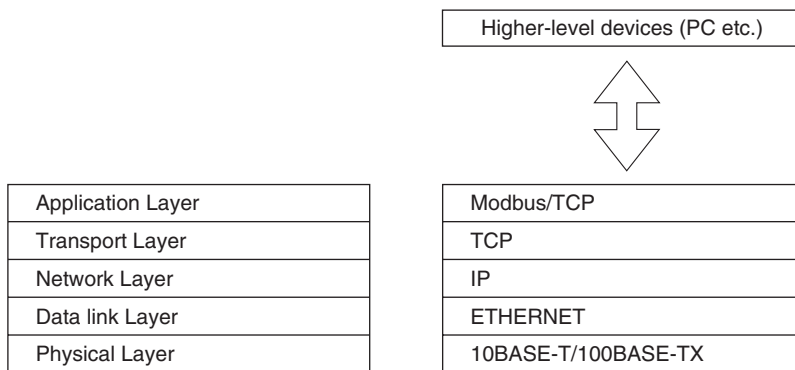

Figure 6.1 Network Layer

(Example)

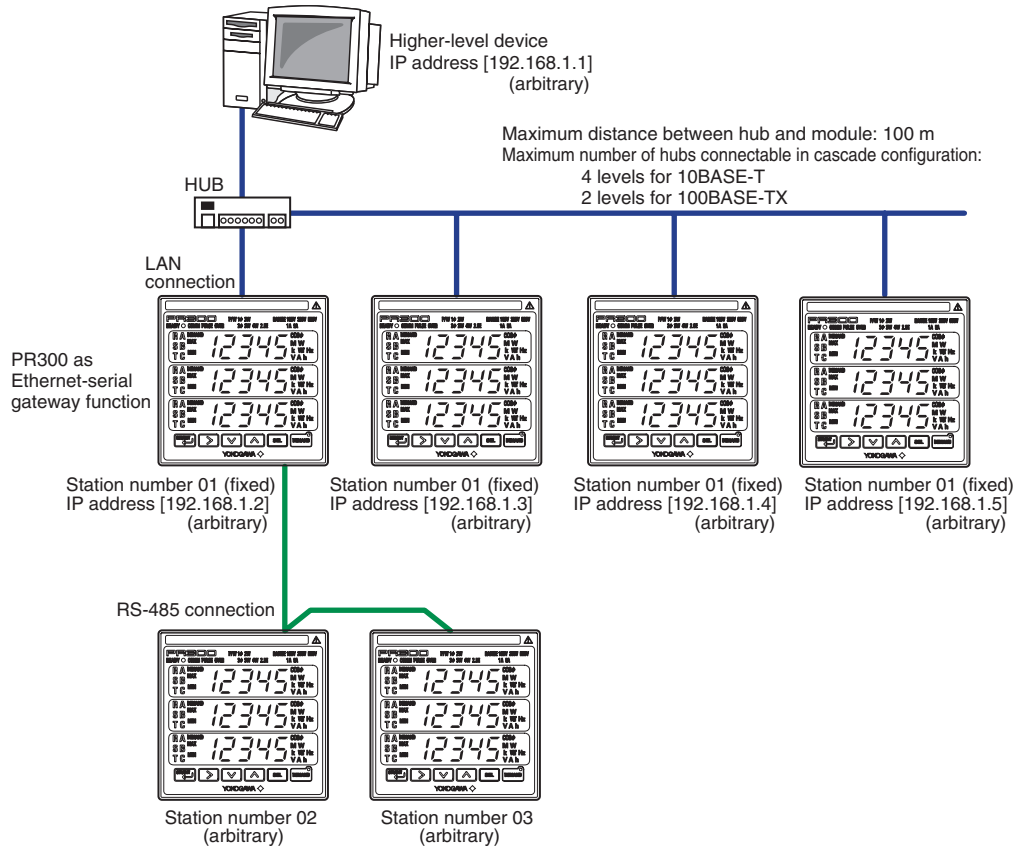

Figure 6.2 Example of Connection for Modbus/TCP Communication

See Also

Chapter 7 for information on the D registers.

6.2 TCP/IP Communication

Modbus/TCP communicates with other devices, following the procedure below, through the TCP/IP socket interface.

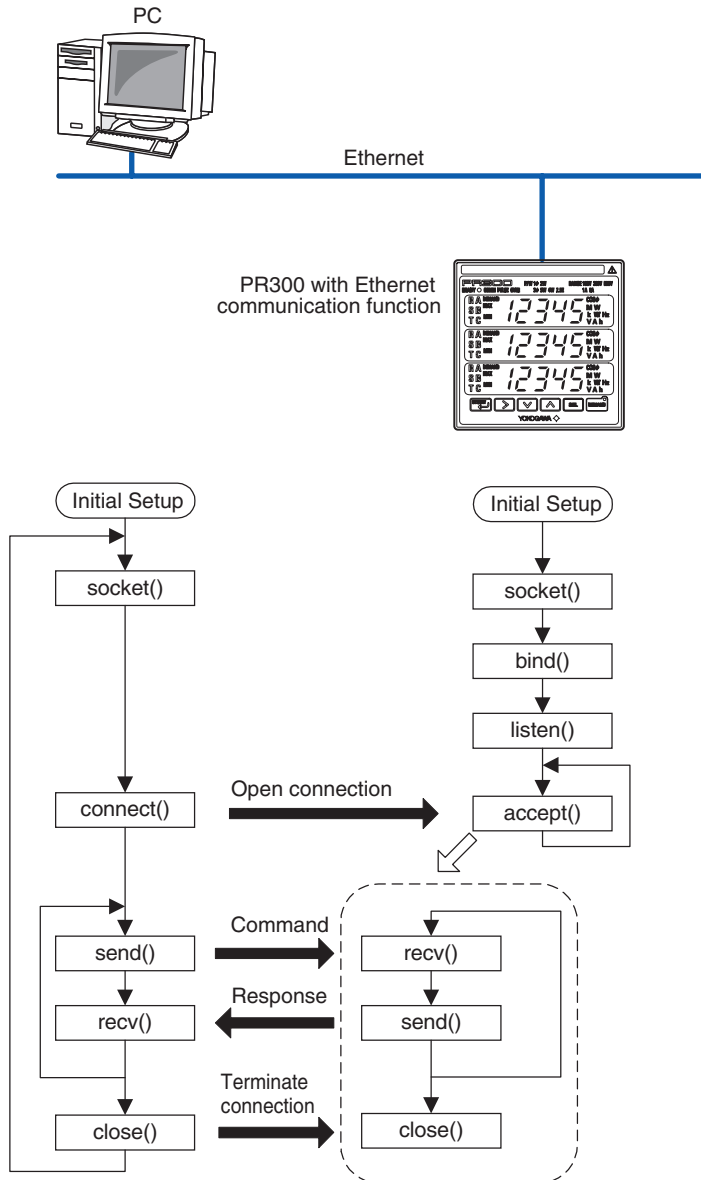

Figure 6.3 TCP/IP Communication

 **NOTE**

If no request is received from the higher-level device for more than 60 seconds after establishing a connection, the PR300 will automatically terminate the connection.

6.3 Network Frame Structure

The Modbus/TCP frame structure is as follows:

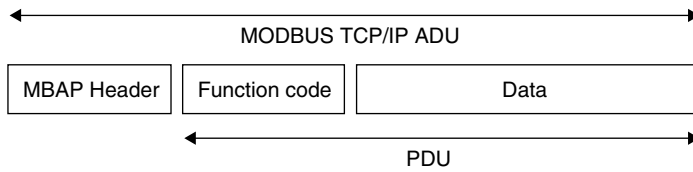

MBAP Header (Modbus Application Protocol Header) : Header used to identify the Modbus/TCP protocol
PDU: simple Protocol Data Unit

6.3.1 MBAP Header Structure

The MBAP Header (Modbus Application Protocol Header) consists of the following seven bytes.

Byte No	0	1	2	3	4	5	6
Description	Transaction ID		Protocol ID		Number of bytes		Unit ID

Transaction ID: Set any value for identifying the transaction. The PR300 returns a value received from a higher-level device as a response.

Protocol ID: Specify "0" for the Modbus/TCP protocol.

Number of bytes: Number of bytes after the unit ID (byte number 6)

Unit ID: For the communication with the PR300 itself, specify "01" for the higher-level device. The PR300 returns "01" as a response. For the communication with the device connected to the RS-485 communication terminals of the PR300 using the Ethernet-serial gateway function, specify its station number (02 to 99). The device returns the same value as a response.

6.3.2 PDU Structure

The PDU (simple Protocol Data Unit) consists of the following *n* bytes.

Byte No	0	1 to (n-1)
Description	Function code	Data

Function code: Specify a command (function code) from a higher-level device.

Data: Specify D register numbers, number of D registers, parameter values, or others in accordance with the function code. (expressed in hexadecimal in the request)

6.4 Communication with Higher-level Devices

6.4.1 List of Function Codes

The codes in the following list are command words higher-level devices use to acquire information from the internal registers (D registers) of the PR300.

Code	Function	Description
03	Reads data from multiple D registers.	Capable of reading data from a maximum of 64 successive D registers between D0001 and D0400.
06	Writes data into D register.	Capable of writing data to one D register between D0001 and D0400.
08	Performs loop back test.	Used when checking communication wiring.
16	Writes data into multiple D registers.	Capable of writing data into a maximum of 32 successive register between D0001 and D0400.

The write function codes cannot be written into read-only or use-prohibited D registers.

6.4.2 Specifying D Registers

Follow the procedures below to specify a D register from a higher-level device:

- (1) If using commercially available SCADA or other software, specify the Ref No. indicated in Chapter 7, "Functions and Usage of D Registers."
- (2) For customer-created communication programs, specify the H No. indicated in Chapter 7, "Functions and Usage of D Registers."

Example: To specify D0301 as the integration start/stop,

*Specify Ref. No. 40301 for a request using commercially available SCADA or other software.

*Specify H No. "012C" for a request using customer-created communication program.

6.4.3 Request and Response

03 Reads data from multiple D registers

● Function

This function code reads the contents of successive D registers by the specified number starting with a specified D registers number.

- The maximum number of D registers to be read at a time is 64.
- For the format of responses in the event of failure, see subsection 6.4.4.

● Request (for normal operation): Reading data from n registers

Element	MBAP Header				PDU		
Number of bytes	2	2	2	1	1	2	2
Command element	Transaction ID	Protocol ID	Number of bytes	Unit ID	Function code	Register start number	Number of registers
Hex value	Arbitrary	0000	0006	01 to 99	03		n

● Response (for normal operation)

Element	MBAP Header				PDU				
Number of bytes	2	2	2	1	1	1	2		2
Command element	Transaction ID	Protocol ID	Number of bytes	Unit ID	Function code	Byte count	Contents of register 1	Contents of register n
Hex value	Arbitrary	0000	2n+3	01 to 99	03	2n			

● Example

Read a series of four D registers starting with D0201 (VT ratio and CT ratio) at station number 01.

[Request] 000100000006010300C80004

↑ ↑ ↑ ↑ ↑ ↑ ↑
 (1) (2) (3) (4) (5) (6) (7)

- (1) "0001": Arbitrary 2-byte data
- (2) "0000": Protocol ID=0000 (fixed)
- (3) "0006": Number of bytes
- (4) "01": Unit ID = 01 indicating PR300
- (5) "03": Function code 03
- (6) "00C8": D register start number 201
- (7) "0004": Number of D registers = 4

The following response will be returned to the request above:

[Response] 00010000000B010308000003F8000003F80

↑ ↑ ↑ ↑ ↑ ↑ ↑ ↑
 (1) (2) (3) (4) (5) (6) D0201 and D0202 D0203 and D0204

* The VT ratio and CT ratio data are floating point values. The combined value of D0201 and D0202, 00003F80, represents 1. That of D0203 and D0204, which is also 00003F80, represents 1 as well (the upper four digits, 3F80, and the lower four digits, 0000, are reversed).

* The floating point value of 3F800000 is the decimal equivalent of 1.

- (1) "0001": The arbitrary 2-byte data in the request
- (2) "0000": Protocol ID = 0000 (fixed)
- (3) "000B": Number of bytes
- (4) "01": Unit ID = 01 indicating PR300
- (5) "03": Function code 03
- (6) "08": Byte count

* Numbers in quotation marks are hexadecimal.

06 Writes data into D register

● Function

This function code writes data into a specified D register number.

- The maximum number of D registers to be written into at a time is 1.
- For the format of response in the event of failure, see subsection 6.4.4.

● Request (for normal operation)

Element	MBAP Header				PDU		
	2	2	2	1	1	2	2
Number of bytes	Transaction ID	Protocol ID	Number of bytes	Unit ID	Function code	Register start number	Write data
Command element	Arbitrary	0000	0006	01 to 99	06		
Hex value							

● Response (for normal operation)

Element	MBAP Header				PDU		
	2	2	2	1	1	2	2
Number of bytes	Transaction ID	Protocol ID	Number of bytes	Unit ID	Function code	Register start number	Write data
Command element	Arbitrary	0000	0006	01 to 99	06		
Hex value							

● Example

Write 5 (500Wh/pls) into the D0209 (pulse unit) at station number 01.

[Request] 000100000006010600D00005
 ↑ ↑ ↑ ↑ ↑ ↑ ↑
 (1) (2) (3) (4) (5) (6) (7)

- (1) "0001": Arbitrary 2-byte data
- (2) "0000": Protocol ID=0000 (fixed)
- (3) "0006": Number of bytes
- (4) "01": Unit ID=01 indicating PR300
- (5) "06": Function code=06
- (6) "00D0": D register number 209
- (7) "0005": Write data

The following response will be returned to the request above.

[Response] 000100000006010600D00005
 ↑ ↑ ↑ ↑ ↑ ↑ ↑
 (1) (2) (3) (4) (5) (6) (7)

- (1) "0001": Arbitrary 2-byte data in the request
- (2) "0000": Protocol ID=0000 (fixed)
- (3) "0006": Number of bytes
- (4) "01": Unit ID=01 indicating PR300
- (5) "06": Function code=06
- (6) "00D0": D register number 209
- (7) "0005": Write data

* Numbers in quotation marks are hexadecimal.

08 Performs loop back test

● Function

This function code is used to check connection for communication.

- For the format of response in the event of failure, see subsection 6.4.4.
- The “0000” shown below (marked with an asterisk *) are fixed.
- Any value can be selected for transmit data.

● Request (for normal operation)

Element	MBAP Header				PDU		
	Transaction ID	Protocol ID	Number of bytes	Unit ID	Function code	0000*	Transmit data
Number of bytes	2	2	2	1	1	2	2
Command element	Transaction ID	Protocol ID	Number of bytes	Unit ID	Function code	0000*	Transmit data
Hex value	Arbitrary	0000	0006	01 to 99	08	0000	Arbitrary

● Response (for normal operation)

Element	MBAP Header				PDU		
	Transaction ID	Protocol ID	Number of bytes	Unit ID	Function code	0000*	Transmit data
Number of bytes	2	2	2	1	1	2	2
Command element	Transaction ID	Protocol ID	Number of bytes	Unit ID	Function code	0000*	Transmit data
Hex value	Arbitrary	0000	0006	01 to 99	08	0000	Arbitrary

● Example

Send “1234” in hex to the PR300 to check the communication connection.

[Request] 000100000006010800001234

↑ ↑ ↑ ↑ ↑ ↑
 (1) (2) (3) (4) (5) (6)

- (1) “0001”: Arbitrary 2-byte data (2) “0000”: Protocol ID=0000 (fixed)
 (3) “0006”: Number of bytes (4) “01”: Unit ID=01 indicating PR300
 (5) “08”: Function code=08 (6) “1234”: Transmit data

The following response will be returned to the request above.

[Response] 000100000006010800001234

↑ ↑ ↑ ↑ ↑ ↑
 (1) (2) (3) (4) (5) (6)

- (1) “0001”: Arbitrary 2-byte data in the request
 (2) “0000”: Protocol ID=0000 (fixed) (3) “0006”: Number of bytes
 (4) “01”: Unit ID=01 indicating PR300 (5) “08”: Function code=08
 (6) “1234”: Transmit data

* Numbers in quotation marks are hexadecimal.

16 Writes data into multiple D registers

● Function

This function code writes data into successive D registers by the number starting with a specified D registers number.

- The maximum number of D registers to be written into at a time is 32.
- For the format of response in the event of failure, see subsection 6.4.4.
- Broadcast addressing is possible (by setting “00” to the station number). No response is returned when using the broadcast addressing.

● Request (for normal operation): Writing data to n registers

Element	MBAP Header				PDU		
Number of bytes	2	2	2	1	1	2	2
Command element	Transaction ID	Protocol ID	Number of bytes	Unit ID	Function code	Register start number	Number of registers
Hex value	Arbitrary	0000	2n+7	01 to 99	10		n

Request (continued)

PDU			
1	2		2
Byte count	Data 1	Data n
2n			

● Response (for normal operation)

Element	MBAP Header				PDU		
Number of bytes	2	2	2	1	1	2	2
Command element	Transaction ID	Protocol ID	Number of bytes	Unit ID	Function code	Register start number	Number of registers
Hex value	Arbitrary	0000	0006	01 to 99	10		n

● Example

Set both the VT ratio and CT ratio to 1.

[Request] 00010000000F011000C800040800003F8000003F80

↑ ↑ ↑ ↑ ↑ ↑ ↑ ↑ ↑ ↑
 (1) (2) (3) (4) (5) (6) (7) (8) D0201 and D0202 D0203 and D0204

- (1) "0001": Arbitrary 2-byte data
- (2) "0000": Protocol ID = 0000 (fixed)
- (3) "000F": Number of bytes
- (4) "01": Unit ID = 01 indicating PR300
- (5) "10": Function code = 16
- (6) "00C8": D register start number 201
- (7) "0004": Number of registers = 4
- (8) "08": Byte count

* The VT ratio and CT ratio data are floating point values.
 The combined value of D0201 and D0202, 00003F80, represents 1. That of D0203 and D0204, which is also 00003F80, represents 1 as well (the upper four digits, 3F80, and the lower four digits, 0000, are reversed).
 * The floating point value of 3F800000 is the decimal equivalent of 1.

The following response will be returned to the request above:

[Response] 000100000006011000C80004

↑ ↑ ↑ ↑ ↑ ↑ ↑
 (1) (2) (3) (4) (5) (6) (7)

- (1) "0001": Arbitrary 2-byte data
- (2) "0000": Protocol ID = 0000 (fixed)
- (3) "0006": Number of bytes
- (4) "01": Unit ID = 01 indicating PR300
- (5) "10": Function code = 16
- (6) "00C8": D register start number 201
- (7) "0004": Number of D registers = 4

* Numbers in quotation marks are hexadecimal.

6.4.4 Response Error Codes

● When a response is returned

If an inconsistency is found in a request's PDU, the PR300 ignores the request and returns the following response.

Element	MBAP Header				PDU	
Number of bytes	2	2	2	1	1	1
Command element	Transaction ID	Protocol ID	Number of bytes	Unit ID	Function code	Error code
Hex value	Arbitrary	0000	03	01 to 99		

*The function code entered here is the request's function code (in hex) plus 80 (in hex).

● Response Error Codes

Error Code	Meaning	Cause
01	Function code error	Function code does not exist.
02	Abnormal D register number	D register number out of the range is specified.
03	Abnormal number of D registers	Number of D registers out of the range is specified.

● When a response is not returned

In the following cases, the PR300 ignores the request and does not return a response.

- When no connection is established at the TCP/IP socket interface.
- When an inconsistency is found in a request's MBAP header.
- When the communication with the serial communication device specified in Unit ID is unusual.

Note: As a measure against the abovementioned problems, add a time-out process to the communication function or program of the higher-level device.

6.5 Sample Program

6.5.1 Example of BASIC Program for Send and Receive

This section shows an example of a command sending and response receiving program created with Visual-Basic*2 for PC/AT*1 (or compatible machines).

*1 PC/AT is the product of IBM Ltd.

*2 Visual-BASIC is a registered trademark of Microsoft Corporation in the United States.

(Example)

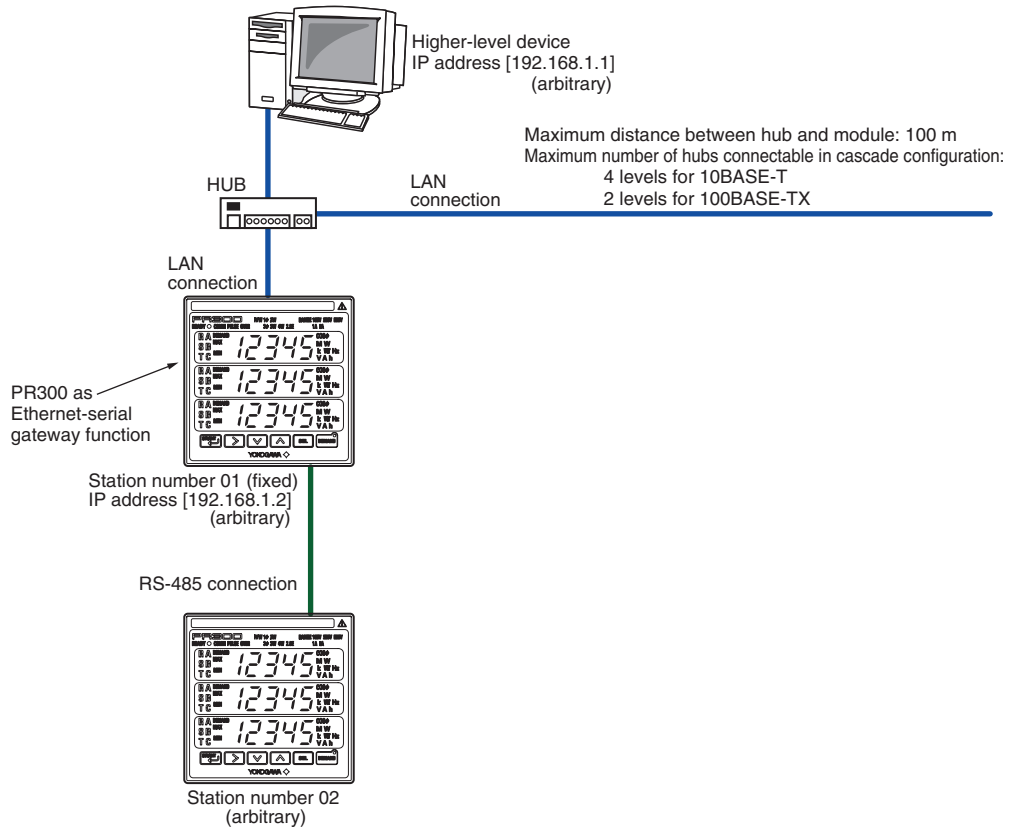

Example of the Program Created Using Visual-BASIC Version 6.0

In this sample program, command sending and response receiving are carried out by the method for connection and sending and SendData method of Winsock control.

● Preparation

Since this sample program uses Winsock control, it is necessary to assign the Microsoft Winsock Control component. Refer to the user’s manual of Visual-Basic for how to assign the component.

● Sample Program

Normal status check, error processing and retry processing are omitted for this procedure.

The program does not operate by the procedure described in this section only. Please make it reference at the time of actual application creation.

```

'Variable declaration
'
Option Explicit
Dim strSendData As String           'Sending data
Dim strReceive As String           'Received data
Dim binChrs(11) As Byte            'Binary data
Dim iFlag As Integer              'Flag of wait for completion
'
'=====
Private Sub cmdSend1()
'Procedure to connect with PR300 by TCP/IP and to create/send data.
'
'Variable declaration
Dim iCount As Integer
Dim strCher As String
'
'Set properties of Winsock control
Winsock1.Protocol = sckTCPProtocol    'TCP protocol
Winsock1.RemoteHost = "192.168.1.1"  'IP address of PR300 to be connected
Winsock1.RemotePort = 502            'Port of Modbus/TCP to be used
'
'Request TCP connection of PR300
Winsock1.Connect                     'Request TCP connection

Do Until Winsock1.State = sckConnected 'Wait for the completion of connection
    iFlag = DoEvents()
Loop
'

```

7. Functions and Usage of D Registers

7.1 Overview of D Registers

This section describes the functions and usage of D registers.

The D registers store the input values, statuses, and others that are handled by the PR300. By connecting the PR300 to higher-level device capable of PC link communication, Modbus communication, or Ethernet communication, you can readily use these internal data items by reading from or writing to the D registers.

7.2 Configuration of D Registers

Register No.	Classification	Description
D0001 to D0100	Process data (measurement data)	Electric energy, instantaneous value and status
D0101 to D0200	Process data (statistics data)	Maximum value and minimum value
D0201 to D0300	Parameter data	Setup conditions such as VT ratio and CT ratio
D0301 to D0400	Control data	Control of operations such as remote reset
Other	Prohibited area (blank)	Cannot be used. Writing to this area is not guaranteed.

7.3 Interpretation of D Register Map Table

This section explains how to read the D Register Map tables in this chapter. The numbers listed in the leftmost column are D register numbers ((1) below). The five-digit numbers in the next column are reference numbers used for Modbus communication ((2) below). The numbers in the column third from left are register numbers in hexadecimal used in Modbus communication programs ((3) below).

D-Reg No.	Ref No.	H No.	Register Symbol	Register Name	Effective Range	Initial Value	Back-up	R/W
D0001	40001	0000	kWh L	Active energy (uint32, lower 2 bytes)	0 to 99,999,999 [kWh]	-	●	R
D0002	40002	0001	kWh H	Active energy (uint32, upper 2 bytes)				

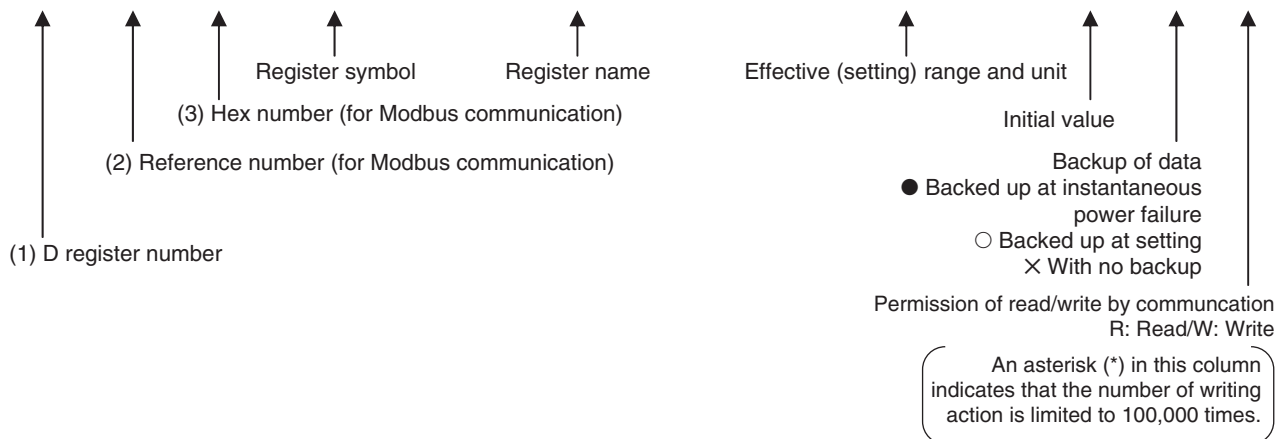

○ Data Format Abbreviations

- float: single precision floating decimal point
- uint: without sign integer
- int: with sign integer

7.4 D Register Map

● Process Data (D0001 to D0146)

D-Reg No.	Ref No.	H No.	Register Symbol	Register Name	Effective Range	Initial Value	BackUp	R/W
D0001	40001	0000	kWh L	Active energy (uint 32, lower 2 bytes)	0 to 99,999,999 [kWh]	-	●	R
D0002	40002	0001	kWh H	Active energy (uint 32, upper 2 bytes)				
D0003	40003	0002	RkWh L	Regenerative energy (uint 32, lower 2 bytes)	0 to 99,999,999 [kWh]	-	●	R
D0004	40004	0003	RkWh H	Regenerative energy (uint 32, upper 2 bytes)				
D0005	40005	0004	Lead kVarh L	LEAD reactive energy (uint 32, lower 2 bytes)	0 to 99,999,999 [kVarh]	-	●	R
D0006	40006	0005	Lead kVarh H	LEAD reactive energy (uint 32, upper 2 bytes)				
D0007	40007	0006	Lag kVarh L	LAG reactive energy (uint 32, lower 2 bytes)	0 to 99,999,999 [kVarh]	-	●	R
D0008	40008	0007	Lag kVarh H	LAG reactive energy (uint 32, upper 2 bytes)				
D0009	40009	0008	kVAh L	Apparent energy (uint 32, lower 2 bytes)	0 to 99,999,999 [kVAh]	-	●	R
D0010	40010	0009	kVAh H	Apparent energy (uint 32, upper 2 bytes)				
D0011	40011	000A	Wh1 L	Optional active energy – current value (uint 32, lower 2 bytes)	0 to 99,999 [Wh]	-	×	R
D0012	40012	000B	Wh1 H	Optional active energy – current value (uint 32, upper 2 bytes)				
D0013	40013	000C	Wh2 L	Optional active energy – previous value (uint 32, lower 2 bytes)	0 to 99,999 [Wh]	-	×	R
D0014	40014	000D	Wh2 H	Optional active energy – previous value (uint 32, upper 2 bytes)				
D0015 to D0020								
D0021	40021	0014	W L	Active power (float, lower 2 bytes)	0.0 to ±9,999,999.9 [W]	-	×	R
D0022	40022	0015	W H	Active power (float, upper 2 bytes)				
D0023	40023	0016	Var L	Reactive power (float, lower 2 bytes)	0.0 to ±9,999,999.9 [Var]	-	×	R
D0024	40024	0017	Var H	Reactive power (float, upper 2 bytes)				
D0025	40025	0018	VA L	Apparent power (float, lower 2 bytes)	0.0 to 9,999,999.9 [VA]	-	×	R
D0026	40026	0019	VA H	Apparent power (float, upper 2 bytes)				
D0027	40027	001A	V1 L	Voltage-1 (float, lower 2 bytes)	0.0 to 9,999,999.9 [V]	-	×	R
D0028	40028	001B	V1 H	Voltage-1 (float, upper 2 bytes)				
D0029	40029	001C	V2 L	Voltage-2 (float, lower 2 bytes)	0.0 to 9,999,999.9 [V]	-	×	R
D0030	40030	001D	V2 H	Voltage-2 (float, upper 2 bytes)				
D0031	40031	001E	V3 L	Voltage-3 (float, lower 2 bytes)	0.0 to 9,999,999.9 [V]	-	×	R
D0032	40032	001F	V3 H	Voltage-3 (float, upper 2 bytes)				
D0033	40033	0020	A1 L	Current-1 (float, lower 2 bytes)	0.000 to 999,999.990 [A]	-	×	R
D0034	40034	0021	A1 H	Current-1 (float, upper 2 bytes)				
D0035	40035	0022	A2 L	Current-2 (float, lower 2 bytes)	0.000 to 999,999.990 [A]	-	×	R
D0036	40036	0023	A2 H	Current-2 (float, upper 2 bytes)				
D0037	40037	0024	A3 L	Current-3 (float, lower 2 bytes)	0.000 to 999,999.990 [A]	-	×	R
D0038	40038	0025	A3 H	Current-3 (float, upper 2 bytes)				
D0039	40039	0026	PF L	Power factor (float, lower 2 bytes)	-0.500 to 1.000 to +0.500	-	×	R
D0040	40040	0027	PF H	Power factor (float, upper 2 bytes)				
D0041	40041	0028	Freq L	Frequency (float, lower 2 bytes)	45.0 to 65.0 [Hz]	-	×	R
D0042	40042	0029	Freq H	Frequency (float, upper 2 bytes)				
D0043	40043	002A	DEMAND W L	Demand power (float, lower 2 bytes)	0.0 to 9,999,999.9 [W]	-	×	R
D0044	40044	002B	DEMAND W H	Demand power (float, upper 2 bytes)				
D0045	40045	002C	DEMAND A1 L	Demand current-1 (float, lower 2 bytes)	0.000 to 999,999.990 [A]	-	×	R
D0046	40046	002D	DEMAND A1 H	Demand current-1 (float, upper 2 bytes)				
D0047	40047	002E	DEMAND A2 L	Demand current-2 (float, lower 2 bytes)	0.000 to 999,999.990 [A]	-	×	R
D0048	40048	002F	DEMAND A2 H	Demand current-2 (float, upper 2 bytes)				
D0049	40049	0030	DEMAND A3 L	Demand current-3 (float, lower 2 bytes)	0.000 to 999,999.990 [A]	-	×	R
D0050	40050	0031	DEMAND A3 H	Demand current-3 (float, upper 2 bytes)				
D0051 to D0098								
D0099	40099	0062	ADERROR ADC	ADC failure (see P.7-6)	-	-	×	R
D0100	40100	0063	ERROR	Various types of error information (see P.7-6)	-	-	×	R
D0101	40101	0064	W MAX L	Maximum active power (float, lower 2 bytes)	0.0 to 9,999,999.9 [W]	0	×	R
D0102	40102	0065	W MAX H	Maximum active power (float, upper 2 bytes)				
D0103	40103	0066	W MIN L	Minimum active power (float, lower 2 bytes)	0.0 to 9,999,999.9 [W]	0	×	R
D0104	40104	0067	W MIN H	Minimum active power (float, upper 2 bytes)				
D0105	40105	0068	Var MAX L	Maximum reactive power (float, lower 2 bytes)	0.0 to 9,999,999.9 [Var]	0	×	R
D0106	40106	0069	Var MAX H	Maximum reactive power (float, upper 2 bytes)				
D0107	40107	006A	Var MIN L	Minimum reactive power (float, lower 2 bytes)	0.0 to 9,999,999.9 [Var]	0	×	R
D0108	40108	006B	Var MIN H	Minimum reactive power (float, upper 2 bytes)				

D-Reg No.	Ref No.	H No.	Register Symbol	Register Name	Effective Range	Initial Value	BackUp	R/W
D0109	40109	006C	VA MAX L	Maximum apparent power (float, lower 2 bytes)	0.0 to 9,999,999.9 [VA]	0	×	R
D0110	40110	006D	VA MAX H	Maximum apparent power (float, upper 2 bytes)				
D0111	40111	006E	VA MIN L	Minimum apparent power (float, lower 2 bytes)	0.0 to 9,999,999.9 [VA]	0	×	R
D0112	40112	006F	VA MIN H	Minimum apparent power (float, upper 2 bytes)				
D0113	40113	0070	V1 MAX L	Voltage-1 maximum value (float, lower 2 bytes)	0.0 to 9,999,999.9 [V]	0	×	R
D0114	40114	0071	V1 MAX H	Voltage-1 maximum value (float, upper 2 bytes)				
D0115	40115	0072	V1 MIN L	Voltage-1 minimum value (float, lower 2 bytes)	0.0 to 9,999,999.9 [V]	0	×	R
D0116	40116	0073	V1 MIN H	Voltage-1 minimum value (float, upper 2 bytes)				
D0117	40117	0074	V2 MAX L	Voltage-2 maximum value (float, lower 2 bytes)	0.0 to 9,999,999.9 [V]	0	×	R
D0118	40118	0075	V2 MAX H	Voltage-2 maximum value (float, upper 2 bytes)				
D0119	40119	0076	V2 MIN L	Voltage-2 minimum value (float, lower 2 bytes)	0.0 to 9,999,999.9 [V]	0	×	R
D0120	40120	0077	V2 MIN H	Voltage-2 minimum value (float, upper 2 bytes)				
D0121	40121	0078	V3 MAX L	Voltage-3 maximum value (float, lower 2 bytes)	0.0 to 9,999,999.9 [V]	0	×	R
D0122	40122	0079	V3 MAX H	Voltage-3 maximum value (float, upper 2 bytes)				
D0123	40123	007A	V3 MIN L	Voltage-3 minimum value (float, lower 2 bytes)	0.0 to 9,999,999.9 [V]	0	×	R
D0124	40124	007B	V3 MIN H	Voltage-3 minimum value (float, upper 2 bytes)				
D0125	40125	007C	A1 MAX L	Current-1 maximum value (float, lower 2 bytes)	0.000 to 999,999.990 [A]	0	×	R
D0126	40126	007D	A1 MAX H	Current-1 maximum value (float, upper 2 bytes)				
D0127	40127	007E	A2 MAX L	Current-2 maximum value (float, lower 2 bytes)	0.000 to 999,999.990 [A]	0	×	R
D0128	40128	007F	A2 MAX H	Current-2 maximum value (float, upper 2 bytes)				
D0129	40129	0080	A3 MAX L	Current-3 maximum value (float, lower 2 bytes)	0.000 to 999,999.990 [A]	0	×	R
D0130	40130	0081	A3 MAX H	Current-3 maximum value (float, upper 2 bytes)				
D0131	40131	0082	PF MAX L	Maximum power factor (float, lower 2 bytes)	-0.500 to 1.000 to +0.500	0	×	R
D0132	40132	0083	PF MAX H	Maximum power factor (float, upper 2 bytes)				
D0133	40133	0084	PF MIN L	Minimum power factor (float, lower 2 bytes)	-0.500 to 1.000 to +0.500	0	×	R
D0134	40134	0085	PF MIN H	Minimum power factor (float, upper 2 bytes)				
D0135	40135	0086	Freq MAX L	Maximum frequency (float, lower 2 bytes)	45.0 to 65.0 [Hz]	0	×	R
D0136	40136	0087	Freq MAX H	Maximum frequency (float, upper 2 bytes)				
D0137	40137	0088	Freq MIN L	Minimum frequency (float, lower 2 bytes)	45.0 to 65.0 [Hz]	0	×	R
D0138	40138	0089	Freq MIN H	Minimum frequency (float, upper 2 bytes)				
D0139	40139	008A	DEMAND W MAX L	Maximum demand power (float, lower 2 bytes)	0.0 to 9,999,999.9 [W]	0	×	R
D0140	40140	008B	DEMAND W MAX H	Maximum demand power (float, upper 2 bytes)				
D0141	40141	008C	DEMAND A1 MAX L	Demand current-1 maximum value (float, lower 2 bytes)	0.000 to 999,999.990 [A]	0	×	R
D0142	40142	008D	DEMAND A1 MAX H	Demand current-1 maximum value (float, upper 2 bytes)				
D0143	40143	008E	DEMAND A2 MAX L	Demand current-2 maximum value (float, lower 2 bytes)	0.000 to 999,999.990 [A]	0	×	R
D0144	40144	008F	DEMAND A2 MAX H	Demand current-2 maximum value (float, upper 2 bytes)				
D0145	40145	0090	DEMAND A3 MAX L	Demand current-3 maximum value (float, lower 2 bytes)	0.000 to 999,999.990 [A]	0	×	R
D0146	40146	0091	DEMAND A3 MAX H	Demand current-3 maximum value (float, upper 2 bytes)				
D0147 to D0200								

* D register with a blank cannot be used. (Writing to this area is not guaranteed.)

● Parameter/Control Data (D0201 to D0400)

D-Reg No.	Ref No.	H No.	Register Symbol	Register Name	Effective Range	Initial Value	BackUp	R/W
D0201	40201	00C8	VT L	VT ratio (float, lower 2 bytes)	1 to 6000	1	○	R/W
D0202	40202	00C9	VT H	VT ratio (float, upper 2 bytes)				
D0203	40203	00CA	CT L	CT ratio (float, lower 2 bytes)	0.05 to 32000	1	○	R/W
D0204	40204	00CB	CT H	CT ratio (float, upper 2 bytes)				
D0205	40205	00CC	LOWCUT L	Integrated low-cut power (float, lower 2 bytes)	0.05 to 20.00 [%]	0.05	○	R/W
D0206	40206	00CD	LOWCUT H	Integrated low-cut power (float, upper 2 bytes)				
D0207	40207	00CE	SET STS	Setup change status	If other than 1: Invalid If 1: Writing is executed (D0201 to D0206 are validated)	–	×	W
D0208	40208	00CF	PULSE SLCT	Measurement item for pulse output	0: Active energy 1: Regenerative energy 2: LEAD reactive energy 3: LAG reactive energy 4: Apparent energy	0	○	R/W
D0209	40209	00D0	PULSE	Pulse unit (uint 16)	1 to 50000 [100wh/pls]	10	○	R/W
D0210	40210	00D1	PULSE WIDTH	ON pulse width (uint 8)	1 to 127 [10ms]	5	○	R/W
D0211	40211	00D2	PULSE STS	Pulse output writing status	If other than 1: Invalid If 1: Writing is executed (D0208 to D0210 are validated)	–	×	W
D0212	40212	00D3	AOUT SLCT	Measurement item for analog output	0: Active power, 1: Reactive power 2: Apparent power, 3: Voltage-1 4: Voltage-2, 5: Voltage-3 6: Current-1, 7: Current-2 8: Current-3, 9: Power factor 10: Frequency	0	○	R/W
D0213	40213	00D4	LOWER SCAL L	Lower limit of scaling (float, lower 2 bytes)	0.0 to 50.0 [%]	50	○	R/W
D0214	40214	00D5	LOWER SCAL H	Lower limit of scaling (float, upper 2 bytes)				
D0215	40215	00D6	UPPER SCAL L	Upper limit of scaling (float, lower 2 bytes)	50.0 to 100.0 [%]	100	○	R/W
D0216	40216	00D7	UPPER SCAL H	Upper limit of scaling (float, upper 2 bytes)				
D0217	40217	00D8	ANALOG AOUT STS	Analog output writing status	If other than 1: Invalid If 1: Writing is executed (D0212 to D0216 are validated)	–	×	W
D0218	40218	00D9	DEMAND SLCT	Demand power/current	0: Active power, 1: Current	0	○	R/W
D0219	40219	00DA	DEMAND INTERVAL TIME	Demand period	1 to 60 [minute] (Demand alarm mask time to 60 [minute])	30	○	R/W
D0220	40220	00DB	DEMAND ALM MASK TIME	Demand alarm mask time	1 to 59 [minute] (1 to Demand period [minute])	1	○	R/W
D0221	40221	00DC	DEMAND ALM W L	Demand power alarm point (float, lower 2 bytes)	1 to 1000 [kW]	100	○	R/W
D0222	40222	00DD	DEMAND ALM W H	Demand power alarm point (float, upper 2 bytes)				
D0223	40223	00DE	DEMAND ALM A L	Demand current alarm point (float, lower 2 bytes)	1 to 1000 [A]	100	○	R/W
D0224	40224	00DF	DEMAND ALM A H	Demand current alarm point (float, upper 2 bytes)				
D0225	40225	00E0	DEMAND ALM RESET	Demand alarm release function	0: Automatic release 1: Manual release	0	○	R/W
D0226	40226	00E1	DEMAND STS	Demand measurement writing status	If other than 1: Invalid If 1: Writing is executed (D0218 to D0225 are validated)	–	×	W
D0227 to D0270								
D0271	40271	010E	PSL	Protocol	0: PC link (without checksum) 1: PC link (with checksum) 2: Modbus ASCII 3: Modbus RTU 4: Modbus TCP 5: PR201 original	1	○	R/W
D0272	40272	010F	BPS	Baud rate	0: 2400 bps, 1: 9600 bps, 2: 19200 bps	1	○	R/W
D0273	40273	0110	PRI	Parity	0: NONE, 1: EVEN, 2: ODD	0	○	R/W
D0274	40274	0111	STP	Stop bit	1: 1 bit, 2: 2 bit	1	○	R/W
D0275	40275	0112	DLN	Data length	0: 8 bit, 1: 7 bit	0	○	R/W
D0276	40276	0113	ST-No.	Station number	01 to 99	01	○	R/W
D0277	40277	0114	RS485 STS	RS-485 writing status	If other than 1: Invalid If 1: Writing is executed (D0271 to D0276 are validated)	–	×	W
D0278 to D0280								
D0281	40281	0118	IP ADDRESS 1	IP address-1 (uint 32, 1 byte)	0 to 255	192	○	R/W
D0282	40282	0119	IP ADDRESS 2	IP address-2 (uint 32, 1 byte)	0 to 255	168	○	R/W
D0283	40283	011A	IP ADDRESS 3	IP address-3 (uint 32, 1 byte)	0 to 255	1	○	R/W
D0284	40284	011B	IP ADDRESS 4	IP address-4 (uint 32, 1 byte)	0 to 255	1	○	R/W
D0285	40285	011C	SUBNET MASK 1	Subnet mask-1 (uint 32, 1 byte)	0 to 255	255	○	R/W
D0286	40286	011D	SUBNET MASK 2	Subnet mask-2 (uint 32, 1 byte)	0 to 255	255	○	R/W
D0287	40287	011E	SUBNET MASK 3	Subnet mask-3 (uint 32, 1 byte)	0 to 255	255	○	R/W
D0288	40288	011F	SUBNET MASK 4	Subnet mask-4 (uint 32, 1 byte)	0 to 255	0	○	R/W

D-Reg No.	Ref No.	H No.	Register Symbol	Register Name	Effective Range	Initial Value	BackUp	R/W
D0289	40289	0120	DEFAULT GATEWAY 1	Default gateway-1 (uint 32, 1 byte)	0 to 255	0	○	R/W
D0290	40290	0121	DEFAULT GATEWAY 2	Default gateway-2 (uint 32, 1 byte)	0 to 255	0	○	R/W
D0291	40291	0122	DEFAULT GATEWAY 3	Default gateway-3 (uint 32, 1 byte)	0 to 255	0	○	R/W
D0292	40292	0123	DEFAULT GATEWAY 4	Default gateway-4 (uint 32, 1 byte)	0 to 255	0	○	R/W
D0293	40293	0124	PORT NUM	Port number	502, 1024 to 65535	502	○	R/W
D0294	40294	0125	ETHERNET STS	Ethernet writing status	If other than 1: Invalid If 1: Writing is executed (D0281 to D0293 are validated)	—	×	W
D0295 to D0300								
D0301	40301	012C	INTEG START STOP	Integration start/stop	0: Stop, 1: Start	1	○	R/W
D0302	40302	012D	Wh START STOP	Optional integration start/stop	0: Stop, 1: Start	0	×	R/W
D0303 to D0310								
D0311	40311	0136	DEMAND START STOP	Demand measurement start/stop	0: Stop, 1: Start	0	×	R/W
D0312	40312	0137	DEMAND ALM STATUS	Confirmation and release of demand alarm state	0: Normal state, 1: Alarm state Writing "0" during alarm state clears the alarm.	0	×	R/W
D0313 to D0350								
D0351	40351	015E	MAX RST	Maximum/minimum values reset	If other than 1: Invalid If 1: Maximum/minimum values are reset (D0101 to D0138)	—	×	W
D0352	40352	015F	Wh ALL RST	Energy value all-reset	If other than 1: Invalid If 1: All energy values are reset (D0001 to D0010)	—	×	W
D0353	40353	0160	kWh RST	Active energy reset	If other than 1: Invalid If 1: Active energy is reset (D0001, D0002)	—	×	W
D0354	40354	0161	RkWh RST	Regenerative energy reset	If other than 1: Invalid If 1: Regenerative energy is reset (D0003, D0004)	—	×	W
D0355	40355	0162	kVarh RST	Reactive energy reset	If other than 1: Invalid If 1: Reactive energy is reset (D0005 to D0008)	—	×	W
D0356	40356	0163	kVAh RST	Apparent energy reset	If other than 1: Invalid If 1: Apparent energy is reset (D0009, D0010)	—	×	W
D0357 to D0370								
D0371	40371	0172	kWh SET L	Active energy – setpoint (uint 32, lower 2 bytes)	See subsection 3.6.1	—	×	W
D0372	40372	0173	kWh SET H	Active energy – setpoint (uint 32, upper 2 bytes)	See subsection 3.6.1	—	×	W
D0373	40373	0174	kWh STS	Active energy writing status	If other than 1: Invalid If 1: The values of D0371 and D0372 are written as the integrated values.	—	×	W
D0374	40374	0175	RkWh L	Regenerative energy – setpoint (uint 32, lower 2 bytes)	See subsection 3.6.2	—	×	W
D0375	40375	0176	RkWh H	Regenerative energy – setpoint (uint 32, upper 2 bytes)	See subsection 3.6.2	—	×	W
D0376	40376	0177	RkWh STS	Regenerative energy writing status	If other than 1: Invalid If 1: The values of D0374 and D0375 are written as the integrated values.	—	×	W
D0377	40377	0178	Lead kVarh SET L	LEAD reactive energy – setpoint (uint 32, lower 2 bytes)	See subsection 3.6.3	—	×	W
D0378	40378	0179	Lead kVarh SET H	LEAD reactive energy – setpoint (uint 32, upper 2 bytes)	See subsection 3.6.3	—	×	W
D0379	40379	017A	Lag kVarh SET L	LAG reactive energy – setpoint (uint 32, lower 2 bytes)	See subsection 3.6.4	—	×	W
D0380	40380	017B	Lag kVarh SET H	LAG reactive energy – setpoint (uint 32, upper 2 bytes)	See subsection 3.6.4	—	×	W
D0381	40381	017C	kVarh STS	Reactive energy writing status	If other than 1: Invalid If 1: The values of D0377 to D0380 are written as the integrated values.	—	×	W
D0382	40382	017D	kVAh SET L	Apparent energy – setpoint (uint 32, lower 2 bytes)	See subsection 3.6.5	—	×	W
D0383	40383	017E	kVAh SET H	Apparent energy – setpoint (uint 32, upper 2 bytes)	See subsection 3.6.5	—	×	W
D0384	40384	017F	kVAh STS	Apparent energy writing status	If other than 1: Invalid If 1: The values of D0382 and D0383 are written as the integrated values.	—	×	W
D0385 to D0399								
D0400	40400	018F	RMT RST	Remote reset	If other than 1: Invalid If 1: PR300 is reset (the same effect as turning the power off and then on)	0	×	W

* D register with a blank cannot be used. (Writing to this area is not guaranteed.)

D0099 and D0100 are designed to represent two or more events, such as errors and status, using combinations of bits within the register. If any of the events shown in the following tables occur, the corresponding bit is set to 1. The bit remains 0 if the event does not occur. Note that bits with blank fields in the tables are not in use.

● Bit Information for ADC Failure (D0099)

Bit	Symbol	Failure Status	Description
0 to 14			
15	ADC_COMM_FAIL	ADC communication error	Occurs if the ADC fails.

● Bit Information for Various Types of Errors (D0100)

Bit	Failure Status
0	System data error, calibration data error, parameter error, backup data error
1	EEPROM error
2	Overranged power
3	Overranged apparent power
4	Overranged reactive power
5	Overranged current (A-1)
6	Overranged current (A-2)
7	Overranged current (A-3)
8	Overranged voltage (V-1)
9	Overranged voltage (V-2)
10	Overranged voltage (V-3)
11	Under-ranged voltage (V-1)
12	Under-ranged voltage (V-2)
13	Under-ranged voltage (V-3)
14	Overranged power factor
15	Overranged frequency

8. PR201 Original Communication Protocol

8.1 Overview

This function enables various measured values to be read into a personal computer through the use of a command/response method. There are two ways for reading the values. One is used to read values individually and another to read them in batch mode (where only measurement items in the specified mode can be read).

8.2 Communication Specifications

	PR300
Transmission distance	Approximately 1.2 km maximum (Use of 24 AWG twisted pair cable)
Connection method	Multi-drop connection of up to 32 stations, including a high-level personal computer
Station number	1 to 99
Transmission method	Half-duplex transmission
Synchronization	Start-stop synchronization
Baud rate	19200/9600/2400 bps
Data format	Start bit, one bit
Data bit	8 bits
Parity	None
Stop bit	1 bit
Xon/Xoff control	Unavailable
Communication error handling	If an invalid command is received, it is discarded and no response is returned. Because noise or invalid commands are ignored, the higher-level PC must perform time-out processing. The time-out time must be set to 1 second or more. In addition, when a parameter or data causes an error, an error response must be returned.

Command/response timing:

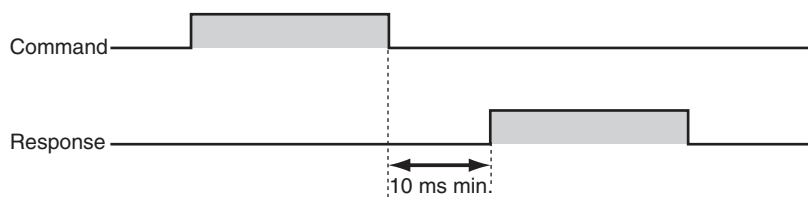

8.3 Command/Response Format

Command components:

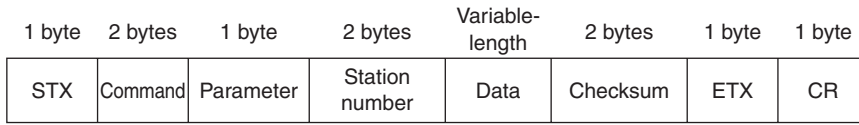

Checksum range

- STX: Start of Text (hexadecimal: 02)
- Command: 2-byte ASCII code (DG or DP)
- Parameter: 1-byte ASCII code (0 to Z)
- Station number: 2-byte ASCII code (01 to 63)
- Data: No data is found at data read-out time. When a setting value is changed, a variable-length ASCII code is set (size in byte varies depending on the parameter).
- Checksum: 2-byte ASCII code (00 to FF)
This value is obtained by adding the data (hex.) in a checksum range and converting the lower 2 digits of the resulting value.
- ETX: End of Text (hexadecimal: 03)
- CR: Carriage Return (hexadecimal: 0D)

Response components:

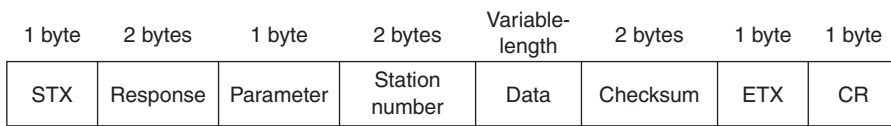

Checksum range

- STX: Start of Text (hexadecimal: 02)
- Response: 2-byte ASCII code (DG or DP)
- Parameter: 1-byte ASCII code (0 to Z)
- Station number: 2-byte ASCII code (01 to 63)
- Data: Variable-length ASCII code (byte size depends on the type of parameter)
- Checksum: 2-byte ASCII code (00 to FF)
- ETX: End of Text (hexadecimal: 03)
- CR: Carriage Return (hexadecimal: 0D)

NOTE

When a communication error occurs, the parameter Z of the DG command must be transmitted to read out an error response. The details of the communication error can be determined by the contents of the error response.

8.4 List of Commands

Parameters common for preceding styles (PR201S1.0, UZ005S2.0)

Parameter	Meaning	Response data			
		Format	Range	Resolution	Size
0	Read measured values in batch.	Data of parameters 1 to 5 and 6 (power factor measurement)			46 bytes
1	Read electric energy	□□□□□	00000 to 99999 [kWh]	1[kWh]	5 bytes
2	Read optional electric (Previous value) energy *1 (Current value)	□□□□□	00000 to 99999 [Wh]	1[Wh]	10 bytes
		□□□□□	00000 to 99999 [Wh]	1[Wh]	
3	Instantaneous power	±□.□□□E+○	±0 to ±9.999E +6 [W]	0.001E+2[W]	9 bytes
4	Instantaneous voltage-1	□.□□□E+○	0 to 9.999E +6 [V]	0.001E+2[V]	8 bytes
5	Instantaneous current-1	□.□□□E+○	0 to 9.999E +5 [A]	0.001E+0[A]	8 bytes
6	Instantaneous power factor	△□.□□□	D0.500 to G1.000 to G0.500	0.001	6 bytes
7	Start optional integration *1	No data			0 byte
8	Stop optional integration *1	No data			0 byte
9	Maximum/minimum values initialization	No data			0 byte
A	Read measured value and maximum/minimum values in batch	Data of parameters 1 to 6 and B to D			70 bytes
B	Read maximum voltage-1 value	□.□□□E+○	0 to 9.999E +6 [V]	0.001E+2[V]	8 bytes
C	Read minimum voltage-1 value	□.□□□E+○	0 to 9.999E +6 [V]	0.001E+2[V]	8 bytes
D	Read maximum current-1 value	□.□□□E+○	0 to 9.999E +5 [A]	0.001E+0[A]	8 bytes
E	Read maximum current-2 value	□.□□□E+○	0 to 9.999E +5 [A]	0.001E+0[A]	8 bytes

Command: DG

Parameter	Meaning	Response data			
		Format	Range	Resolution	Size
2	Read optional electric (Previous value) energy *1 (Current value)	□□□□□	00000 to 99999 [Wh]	1[Wh]	10 bytes
		□□□□□	00000 to 99999 [Wh]	1[Wh]	
3	Instantaneous power	±□.□□□E+○	±0 to ±9.999E +6 [W]	0.001E+2[W]	9 bytes
4	Instantaneous voltage-1	□.□□□E+○	0 to 9.999E +6 [V]	0.001E+2[V]	8 bytes
5	Instantaneous current-1	□.□□□E+○	0 to 9.999E +5 [A]	0.001E+0[A]	8 bytes
6	Instantaneous power factor	△□.□□□	D0.500 to G1.000 to G0.500	0.001	6 bytes
7	Start optional integration *1	No data			0 byte
8	Stop optional integration *1	No data			0 byte
9	Maximum/minimum values initialization	No data			0 byte
B	Read maximum voltage-1 value	□.□□□E+○	0 to 9.999E +6 [V]	0.001E+2[V]	8 bytes
C	Read minimum voltage-1 value	□.□□□E+○	0 to 9.999E +6 [V]	0.001E+2[V]	8 bytes
D	Read maximum current-1 value	□.□□□E+○	0 to 9.999E +5 [A]	0.001E+0[A]	8 bytes
F	Read measured values in batch	Data of parameters G, 2, 3, 4, H, J, 5, K, L and 6 (power factor measurement)			81 byte
G	Read electric energy	□□□□□E+○	00000E+3 to 99999E+6 [Wh]		8 bytes
H	Instantaneous voltage-2	□.□□□E+○	0 to 9.999E +6 [V]	0.001E+2[V]	8 bytes
J	Instantaneous voltage-3	□.□□□E+○	0 to 9.999E +6 [V]	0.001E+2[V]	8 bytes
K	Instantaneous current-2	□.□□□E+○	0 to 9.999E +5 [A]	0.001E+0[A]	8 bytes
L	Instantaneous current-3	□.□□□E+○	0 to 9.999E +5 [A]	0.001E+0[A]	8 bytes
M	Read measured value and maximum/minimum values in batch	Data of parameters G, 2, 3, 4, H, J, 5, K, L, 6 (power factor measurement), B, C, D and N to T			153 bytes
N	Read maximum voltage-2 value	□.□□□E+○	0 to 9.999E +6 [V]	0.001E+2[V]	8 bytes
P	Read maximum voltage-3 value	□.□□□E+○	0 to 9.999E +6 [V]	0.001E+2[V]	8 bytes
Q	Read minimum voltage-2 value	□.□□□E+○	0 to 9.999E +6 [V]	0.001E+2[V]	8 bytes
R	Read minimum voltage-3 value	□.□□□E+○	0 to 9.999E +6 [V]	0.001E+2[V]	8 bytes
S	Read maximum current-2 value	□.□□□E+○	0 to 9.999E +5 [A]	0.001E+0[A]	8 bytes
T	Read maximum current-3 value	□.□□□E+○	0 to 9.999E +5 [A]	0.001E+0[A]	8 bytes
U	---				
V	---				
W	---				
X	Read model and suffix codes	PR201-□□□□□-△△			14 bytes
Y	---				
Z	Error response	□□			2 bytes

*1: When optional integration is started or stopped through communication, the subsequent optional integration control signals are disabled. For this reason, optional integration must be controlled by either communication or optional integration control signals. After a power failure, optional integration control is reset.

Command: DP

Parameter	Meaning	Model	Response data format	Response data range	Response data size
0	Read setting value		No data	See *2 for response	16 byte
1	---				
2	---				
3	---				
4	Set VT ratio	Not available in PR300	□□□□□	00001 to 06000	5 bytes
5	Set CT ratio	Not available in PR300	□□□□□	00.05 to 32000	5 bytes
6	---				
7	---				
8	---				
9	---				
A	Remote reset		No data		0 byte
B	Integrated low-cut power	Not available in PR300	□□.□	00.1 to 99.9	4 bytes
C	Integration pulse unit	Not available in PR300	□.□□□E--○	6.667E -6 to 1.000E-1	8 bytes
D	Integration pulse ON pulse width	Not available in PR300	□□□□	0010 to 1270	4 bytes
E	Analog output scaling "L"	Not available in PR300	△□□□□(△: + or -)	-4800 to +4800	5 bytes
F	Analog output scaling "H"	Not available in PR300	△□□□□(△: + or -)	-4800 to +4800	5 bytes
G	Integration reset		No data (retained data is also reset)		0 byte

*2 The following shows a response to a setting value read command.
VT ratio, CT ratio and integrated low-cut power 16 bytes

8.5 Command Details

■ Command: DG

● Parameter: 0 (Reads measured values in batch)

• Function

This command reads the active energy, optional electric energy (previous and current values), active power, voltage-1, current-1 and the power factor.

• Command/response

Number of bytes	1	2	1	2	2	1	1
Command element	STX	DG	0	Station number (ADR)	Checksum	ETX	CR

There is no command data for data reading.

Number of bytes	1	2	1	2	5	5	5	9
Response element	STX	DG	0	Station number (ADR)	□□□□□□ Active energy	dddd (Previous optional electric energy value)	dddd (Current optional electric energy value)	±□.□□□E+○ (Active power)

Response data is returned as a 46-byte ASCII character string.

Continued:

8	8	6	2	1	1
□.□□□E+○ (Voltage-1)	□.□□□E+○ (Current-1)	△□.□□□ (Power factor)	Checksum	ETX	CR

• Example

The PR300 measured values of station number 01 are read out in a batch. □□ indicates the checksum value.

[Command]

[STX]DG001□□[ETX][CR]

The following response is returned for the above command.

[Response]

[STX]DG001100001000010000+1.000E+31.000E+31.000E+3G0.800□□[ETX][CR]

- (1) Active energy: 10000 kWh, (2) Optional electric energy (previous value): 10000 Wh, (3) Optional electric energy (current value): 10000 Wh, (4) Active power: +1.000E+3 W (10000 W), (5) Voltage-1: 1.000E+3 V (1000 V), (6) Current-1: 1.000E+3 A (1000 A) and (7) Power factor: G0.800.

● **Parameter: 1 (Reads electric energy)**

• **Function**

Reads the active energy.

• **Command/response**

Number of bytes	1	2	1	2	2	1	1
Command element	STX	DG	1	Station number (ADR)	Checksum	ETX	CR

There is no command data for data reading.

Number of bytes	1	2	1	2	5	2	1	1
Response element	STX	DG	1	Station number (ADR)	□□□□□	Checksum	ETX	CR

Response data is returned as a 5-byte ASCII character string (00000 to 99999).

• **Example**

Reads the active energy of PR300 with station number 01. □□ indicates the checksum value.

[Command]

[STX]DG101□□[ETX][CR]

Returns a response with the active energy of 10000 kWh for the above command.

[Response]

[STX]DG10110000□□[ETX][CR]

 **NOTE**

Display ranges of active energy vary depending on the values of the VT and CT ratios. See the following table for display range details.

Secondary rated power x VT ratio x CT ratio	Internal data	PR201 original communication display range
100 kW or less	99999 kWh	99999 kWh
100 kW or more, 1 MW or less	999999 kWh	
1 MW or more, 10 MW or less	9999999 kWh	
10 MW or more	99999999 kWh	

 **NOTE**

The secondary rated power of the PR300 changes depending on its model and suffix codes.

● **Parameter: 2 (Reads optional electric energy)**

• **Function**

Reads the previous value and current value of optional electric energy.

• **Command/response**

Number of bytes	1	2	1	2	2	1	1
Command element	STX	DG	2	Station number (ADR)	Checksum	ETX	CR

There is no command data for data reading.

Number of bytes	1	2	1	2	5	5	2	1	1
Response element	STX	DG	2	Station number (ADR)	dddd (Previous value)	dddd (Current value)	Checksum	ETX	CR

Response data is returned as a 5-byte ASCII character string (00000 to 99999).

• **Example**

Reads the optional electric energy of PR300 with station number 01. □□ indicates the checksum value.

[Command]

[STX]DG201□□[ETX][CR]

Returns 10000 Wh as optional electric energy (previous value) and 10000 Wh as optional electric energy (current value) for the above command.

[Response]

[STX]DG2011000010000□□[ETX][CR]

● **Parameter: 3 (Instantaneous power)**

• **Function**

Reads the active power.

• **Command/response**

Number of bytes	1	2	1	2	2	1	1
Command element	STX	DG	3	Station number (ADR)	Checksum	ETX	CR

There is no command data for data reading.

Number of bytes	1	2	1	2	9	2	1	1
Response element	STX	DG	3	Station number (ADR)	±□.□□□E+○	Checksum	ETX	CR

Response data is returned as a 9-byte ASCII character string (±0.000E+0 to ±9.999E+6).

• **Example**

Reads the active power of PR300 with station number 01. □□ indicates the checksum value.

[Command]

[STX]DG301□□[ETX][CR]

Returns a response of active power 1000 W (+1.000E+3 W) for the above command.

[Response]

[STX]DG301+1.000E+3□□[ETX][CR]

● **Parameter: 4 (Instantaneous voltage-1), Parameter: H (Instantaneous voltage-2), Parameter: J (Instantaneous voltage-3)**

• **Function**

Reads voltage-1 by parameter: 4, voltage-2 by parameter: H and voltage-3 by parameter: J

• **Command/response**

Number of bytes	1	2	1	2	2	1	1
Command element	STX	DG	4 (H) (J)	Station number (ADR)	Checksum	ETX	CR

There is no command data for data reading.

Number of bytes	1	2	1	2	8	2	1	1
Response element	STX	DG	4 (H) (J)	Station number (ADR)	□.□□□E+○	Checksum	ETX	CR

Response data is returned as an 8-byte ASCII character string (0.000E+0 to 9.999E+6).

• **Example**

Reads voltage-1 of PR300 with station number 01. □□ indicates the checksum value.

[Command]

[STX]DG401□□[ETX][CR]

Returns a response of voltage-1: 1000 V (1.000E+3 V) for the above command.

[Response]

[STX]DG4011.000E+3 □□[ETX][CR]

● **Parameter: 5 (Instantaneous current-1), parameter: K (Instantaneous current-2), Parameter: L (Instantaneous current-3)**

• **Function**

Reads current-1 by parameter: 5, current-2 by parameter: K and current-3 by parameter: L.

• **Command/response**

Number of bytes	1	2	1	2	2	1	1
Command element	STX	DG	5 (K) (L)	Station number (ADR)	Checksum	ETX	CR

There is no command data for data reading.

Number of bytes	1	2	1	2	8	2	1	1
Response element	STX	DG	5 (K) (L)	Station number (ADR)	□.□□□E+○	Checksum	ETX	CR

Response data is returned as an 8-byte ASCII character string (0.000E+0 to 9.999E+5)

• **Example**

Reads current-1 of PR300 with station number 01. □□ indicates the checksum value.

[Command]

[STX]DG501□□[ETX][CR]

Returns a response of current-1: 1000 A (1.000E+3 A) for the above command.

[Response]

[STX]DG5011.000E+3 □□[ETX][CR]

● **Parameter: 6 (Instantaneous power factor)**

• **Function**

Reads a power factor.

• **Command/response**

Number of bytes	1	2	1	2	2	1	1
Command element	STX	DG	6	Station number (ADR)	Checksum	ETX	CR

There is no command data for data reading.

Number of bytes	1	2	1	2	6	2	1	1
Response element	STX	DG	6	Station number (ADR)	△□.□□□	Checksum	ETX	CR

Response data is returned as a 6-byte ASCII character string (D0.500 to 1.000 to G0.500).

• **Example**

Reads a power factor of PR300 with station number 01. □□ indicates the checksum value.

[Command]

[STX]DG601□□[ETX][CR]

Returns a response of power factor G0.8 for the above command.

[Response]

[STX]DG601G0.800□□[ETX][CR]

● **Parameter: 7 (Starts optional integration)**

• **Function**

Starts optional integration.

• **Command/response**

Number of bytes	1	2	1	2	2	1	1
Command element	STX	DG	7	Station number (ADR)	Checksum	ETX	CR

There is no command data for data reading.

Number of bytes	1	2	1	2	0	2	1	1
Response element	STX	DG	7	Station number (ADR)	No data	Checksum	ETX	CR

There is no response data.

• **Example**

Starts optional integration of PR300 with station number 01. □□ indicates the checksum value.

[Command]

[STX]DG701□□[ETX][CR]

Returns the following response for the above command.

[Response]

[STX]DG701□□[ETX][CR]

● **Parameter: 8 (Stops optional integration)**

• **Function**

Stops optional integration.

• **Command/response**

Number of bytes	1	2	1	2	2	1	1
Command element	STX	DG	8	Station number (ADR)	Checksum	ETX	CR

There is no command data for data reading.

Number of bytes	1	2	1	2	0	2	1	1
Response element	STX	DG	8	Station number (ADR)	No data	Checksum	ETX	CR

There is no response data.

• **Example**

Stops optional integration of PR300 with station number 01. □□ indicates the checksum value.

[Command]

[STX]DG801□□[ETX][CR]

Returns the following response for the above command.

[Response]

[STX]DG801□□[ETX][CR]

● **Parameter 9: (Initializes maximum and minimum values)**

• **Function**

Initializes the maximum and minimum values (maximum and minimum values of voltage-1 to voltage-3 and maximum value of current-1 to current-3)

• **Command/response**

Number of bytes	1	2	1	2	2	1	1
Command element	STX	DG	9	Station number (ADR)	Checksum	ETX	CR

There is no command data for data reading.

Number of bytes	1	2	1	2	0	2	1	1
Response element	STX	DG	9	Station number (ADR)	No data	Checksum	ETX	CR

There is no response data.

• **Example**

Initializes the maximum and minimum values of PR300 with station number 01. □□ indicates the checksum value.

[Command]

[STX]DG901□□[ETX][CR]

Returns the following response for the above command.

[Response]

[STX]DG901□□[ETX][CR]

● **Parameter: A (Reads measured value and maximum/minimum values in batch)**

• **Function**

Reads the active energy, optional electric energy (previous and current values), active power, voltage-1, current-1, power factor, maximum voltage-1, minimum voltage-1 and maximum current-1.

• **Command/response**

Number of bytes	1	2	1	2	2	1	1
Command element	STX	DG	A	Station number (ADR)	Checksum	ETX	CR

There is no command data for data reading.

Number of bytes	1	2	1	2	5	5	5	9
Response element	STX	DG	A	Station number (ADR)	□□□□□ (Active energy)	ddddd (Previous value of optional electric energy)	ddddd (Current value of optional electric energy)	±□.□□□E+○ (Active power)

Response data is returned as a 70-byte ASCII character string.

Continued

8	8	6	8	8
□.□□□E+○ (Voltage-1)	□.□□□E+○ (Current-1)	△□.□□□ (Power factor)	□.□□□E+○ (Maximum voltage-1)	□.□□□E+○ (Minimum voltage-1)

Continued

8	2	1	1
□.□□□E+○ (Maximum current-1)	Checksum	ETX	CR

• **Example**

Reads in batch the measured values and maximum/minimum value of PR300 with station number 01.

[Command]

[STX]DGA01□□[ETX][CR]

Returns the following response for the above command.

[Response]

[STX]DGA01 $\frac{10000}{(1)}$ $\frac{10000}{(2)}$ $\frac{10000}{(3)}$ $\frac{+1.000E+3}{(4)}$ $\frac{+1.000E+3}{(5)}$ $\frac{+1.000E+3}{(6)}$ $\frac{G0.800}{(7)}$ $\frac{1.000E+3}{(8)}$ $\frac{+1.000E+3}{(9)}$ $\frac{+21.000E+3}{(10)}$ □□[ETX][CR]

(1) Active energy: 10000 kWh, (2) Optional electric energy (previous value): 10000 Wh, (3) Optional electric energy (current value): 10000 Wh, (4) Active power: +1.000E+3 W (1000 W), (5) Voltage-1: 1.000E+3 V (1000 V), (6) Current-1: 1.000E+3 A (1000 A), (7) Power factor: G0.800, (8) Maximum voltage-1: 1.000E+3 V (1000 V), (9) Minimum voltage-1: 1.000E+2 V (100 V), (10) Maximum current-1: 1.000E+3 A (1000 A)

- **Parameter: B (Reads maximum voltage-1), Parameter: C (Reads minimum voltage-1), Parameter: N (Reads maximum voltage-2), Parameter: P (Reads maximum voltage-3), Parameter: Q (Reads minimum voltage-2), Parameter: R (Reads minimum voltage-3)**

• **Function**

Reads the maximum voltage-1 by parameter: B, the minimum voltage-1 by parameter C, the maximum voltage-2 by parameter: N, the maximum voltage-3 by parameter: P, the minimum voltage-2 by parameter: Q, and the minimum voltage-3 by parameter: R.

• **Command/response**

Number of bytes	1	2	1	2	2	1	1
Command element	STX	DG	B (C) (N) (P) (Q) (R)	Station number (ADR)	Checksum	ETX	CR

There is no command data for data reading.

Number of bytes	1	2	1	2	8	2	1	1
Response element	STX	DG	B (C) (N) (P) (Q) (R)	Station number (ADR)	□.□□□E+○	Checksum	ETX	CR

Response data is returned as an 8-byte ASCII character string (0.000E+0 to 9.999E+6).

• **Example**

Reads the maximum voltage-1 of PR300 with station number 01. □□ indicates the checksum value.

[Command]

[STX]DGB01□□[ETX][CR]

Returns a response of the maximum voltage-1: 1000 V (1.000E+3 V) for the above command.

[Response]

[STX]DGB011.000E+3□□[ETX][CR]

● **Parameter: D (Reads maximum current-1), Parameter: E (Reads maximum current-2. Old style), Parameter: S (Reads maximum current-2), Parameter: T (Reads maximum current-3)**

• **Function**

Reads the maximum current-1.

Reads the maximum current-1 by parameter: D, the maximum current-2 by parameters: E and S, and the maximum current-3 by parameter: T.

• **Command/response**

Number of bytes	1	2	1	2	2	1	1
Command element	STX	DG	D (E) (S) (T)	Station number (ADR)	Checksum	ETX	CR

There is no command data for data reading.

Number of bytes	1	2	1	2	8	2	1	1
Response element	STX	DG	D (E) (S) (T)	Station number (ADR)	□.□□□E+○	Checksum	ETX	CR

Response data is returned as an 8-byte ASCII character string (0.000E+0 to 9.999E+5).

• **Example**

Reads the maximum current-1 of PR300 with station number 01. □□ indicates the checksum value.

[Command]

[STTX] DGD01□□[ETX][CR]

Returns a response of the maximum current-1: 1000 A (1.000E+3 A) for the above command.

[Response]

[STX]DGD011.000E+3□□[ETX][CR]

● **Parameter: F (Reads measured values in batch)**

• **Function**

Reads the active energy, optional electric energy (previous and current values), active power, voltage-1, voltage-2, voltage-3, current-1, current-2, current-3 and power factor.

• **Command/response**

Number of bytes	1	2	1	2	2	1	1
Command element	STX	DG	F	Station number (ADR)	Checksum	ETX	CR

There is no command data for data reading.

Number of bytes	1	2	1	2	8	5	5	9
Response element	STX	DG	F	Station number (ADR)	□□□□□E+○ (Active energy)	dddd (Previous value of optional electric energy)	dddd (Current value of optional electric energy)	±□.□□□E+○ (Active power)

Response data is returned as an 81-byte ASCII character string.

Continued

8	8	8	8	8	8
□.□□□E+○ (Voltage-1)	□.□□□E+○ (Voltage-2)	□.□□□E+○ (Voltage-3)	□.□□□E+○ (Current-1)	□.□□□E+○ (Current-2)	□.□□□E+○ (Current-3)

Continued

6	2	1	1
△□.□□□ (Power factor)	Checksum	ETX	CR

• **Example**

Reads the measured values of PR300 with station number 01 in batch. □□ indicates the checksum value.

[Command]

[STX]DGF01□□[ETX][CR]

Returns the following response for the above command.

[Response]

[STX]DGF0110000E+31000010000+1.000E+31.000E+31.000E+31.000E+31.000E+31.000E+3
 (1) (2) (3) (4) (5) (6) (7)
1.000E+31.000E+31.000E+3G0.800□□[ETX][CR]
 (8) (9) (10) (11)

- (1) Active energy: 10000E+3 Wh (10 MWh), (2) Optional electric energy (previous value): 10000 Wh, (3) Optional electric energy (current value): 10000 Wh,
- (4) Active power: +1.000E+3 W (1000 W), (5) Voltage-1: 1.000E+3 V (1000 V),
- (6) Voltage-2: 1.000E+3 V (1000 V), (7) Voltage-3: 1.000E+3 V (1000 V),
- (8) Current-1: 1.000E+3 A (1000 A), (9) Current-2: 1.000E+3 A (1000 A),
- (10) Current-3: 1.000E+3 A (1000 A), (11) Power factor: G0.800

● **Parameter: G (Reads electric energy)**

• **Function**

Reads the active energy.

• **Command/response**

Number of bytes	1	2	1	2	2	1	1
Command element	STX	DG	G	Station number (ADR)	Checksum	ETX	CR

There is no command data for data reading.

Number of bytes	1	2	1	2	8	2	1	1
Response element	STX	DG	G	Station number (ADR)	□□□□□E+○	Checksum	ETX	CR

Response data is returned as an 8-byte ASCII character string (00000E+0 to 99999E+6).

• **Example**

Reads the active energy of PR300 with station number 01. □□ indicates the checksum value.

[Command]

[STX]DGG01□□[ETX][CR]

Returns a response of the active energy: 10 MWh (10000E+3 Wh) for the above command.

[Response]

[STX]DGG0110000E+3□□[ETX][CR]

 **NOTE**

Display ranges of active energy vary depending on the values of the VT and CT ratios. See the following table for display range details.

Secondary rated power x VT ratio x CT ratio	Internal data	PR201 original communication display range	Index display range
100 kW or less	99999 kWh	99999 kWh	99999E+3 Wh
100 kW or more, 1 MW or less	999999 kWh	999990 kWh	99999E+4 Wh
1 MW or more, 10 MW or less	9999999 kWh	9999900 kWh	99999E+5 Wh
10 MW or more	99999999 kWh	99999000 kWh	99999E+6 Wh

 **NOTE**

The secondary rated power of the PR300 changes depending on its model and suffix codes.

● **Parameter: M (Reads measured values and maximum/minimum values in batch)**

• **Function**

Reads the active energy, optional electric energy (previous and current values), active power, voltage-1, voltage-2, voltage-3, current-1, current-2, current-3, power factor, maximum voltage-1, minimum voltage-1, maximum current-1, maximum voltage-2, maximum voltage-3, minimum voltage-2, minimum voltage-3, maximum current-2 and maximum current-3.

• **Command/response**

Number of bytes	1	2	1	2	2	1	1
Command element	STX	DG	M	Station number (ADR)	Checksum	ETX	CR

There is no command data for data reading.

Number of bytes	1	2	1	2	8	5	5	9
Response element	STX	DG	M	Station number (ADR)	□□□□□E+○ (Active energy)	ddddd (Previous value of optional electric energy)	ddddd (Current value of optional electric energy)	±□.□□□E+○ (Active power)

Response data is returned as a 153-byte ASCII character string.

Continued

8	8	8	8	8	8
□.□□□E+○ (Voltage-1)	□.□□□E+○ (Voltage-2)	□.□□□E+○ (Voltage-3)	□.□□□E+○ (Current-1)	□.□□□E+○ (Current-2)	□.□□□E+○ (Current-3)

Continued

6	8	8	8	8	8
△□.□□□ (Power factor)	□.□□□E+○ (Maximum voltage-1)	□.□□□E+○ (Minimum voltage-1)	□.□□□E+○ (Maximum current-1)	□.□□□E+○ (Maximum voltage-2)	□.□□□E+○ (Maximum voltage-3)

Continued

8	8	8	8	2	1	1
□.□□□E+○ (Minimum voltage-2)	□.□□□E+○ (Minimum voltage-3)	□.□□□E+○ (Maximum current-2)	□.□□□E+○ (Maximum current-3)	Checksum	ETX	CR

● **Example**

Reads the measured value and maximum/minimum values of PR300 with station number 01 in batch. □□ indicates the checksum value.

[Command]

[STX]DGM01□□[ETX][CR]

Returns the following response for the above command.

[Response]

[STX]DGM0110000E+31000010000+1.000E+31.000E+31.000E+31.000E+3
 (1) (2) (3) (4) (5) (6) (7)
 1.000E+31.000E+31.000E+3G0.8001.000E+31.000E+21.000E+3
 (8) (9) (10) (11) (12) (13) (14)
 1.000E+31.000E+31.000E+21.000E+21.000E+31.000E+3□□[ETX][CR]
 (15) (16) (17) (18) (19) (20)

(1) Active energy: 10000E+3 Wh (10 MWh), (2) Optional electric energy (previous value): 10000 Wh, (3) Optional electric energy (current value): 10000 Wh, (4) Active power: +1.000E+3 W (1000 W), (5) Voltage-1: 1.000E+3 V (1000 V), (6) Voltage-2: 1.000E+3 V (1000 V), (7) Voltage-3: 1.000E+3 V (1000 V), (8) Current-1: 1.000E+3 A (1000 A), (9) Current-2: 1.000E+3 A (1000 A), (10) Current-3: 1.000E+3 A (1000 A), (11) Power factor: G0.800, (12) Maximum voltage-1: 1.000E+3 V (1000 V), (13) Minimum voltage-1: 1.000E+2 V (100 V), (14) Maximum current-1: 1.000E+3 A (1000 A), (15) Maximum voltage-2: 1.000E+3 V (1000 V), (16) Maximum voltage-3: 1.000E+3 V (1000 V), (17) Minimum voltage-2: 1.000E+2 V (100 V), (18) Minimum voltage-3: 1.000E+2 V (100 V), (19) Maximum current-2: 1.000E+3 A (1000 A), (20) Maximum current-3: 1.000E+3 A (1000 A).

● **Parameter: X (Reads model and suffix codes)**

• **Function**

Returns the model and suffix codes of PR300.

• **Command/response**

Number of bytes	1	2	1	2	2	1	1
Command element	STX	DG	X	Station number (ADR)	Checksum	ETX	CR

There is no command data for data reading.

Number of bytes	1	2	1	2	14	2	1	1
Response element	STX	DG	X	Station number (ADR)	PR201-□□□□□-△△ (Note 1)	Checksum	ETX	CR

Response data is returned in a 14-byte ASCII character string.

Note 1: Information on model and suffix codes

PR201-☆★011-20

<Model> <Suffix code>

☆: Returns the current phase and wire system:

- 1: Single-phase two-wire
- 2: Single-phase three-wire
- 3: Three-phase three-wire
- 4: Three-phase four-wire
- 5: Three-phase four-wire (2.5e)

★: Returns the current rated input:

- 1: 150V/1A
- 2: 150V/5A
- 3: 300V/1A
- 4: 300V/5A
- 5: 600V/1A
- 6: 600V/5A

011: Returns a suffix code.

- 0: Produces neither analog output nor pulse output.
- 1: RS-485 communication
- 1: Power factor measuring function

20: Returns a suffix code.

- 2: 85 to 264 VAC
- 0: Always 0

• **Example**

Reads the format of PR300 with station number 01. □□ indicates the checksum value.

[Command]

[STX]DGX01□□[ETX][CR]

Returns the following response for the above command.

Wire system: Single-phase three-wire, Rated input: 300V/5A, I/O: Without analog output, without pulse output, Communication: RS-485 communication, Measurement: Power factor measurement

[Response]

[STX]DGX01PR201-24011-20□□[ETX][CR]



NOTE

When reading the model and suffix codes of PR300, “PR201” is returned as model name because of the compatibility with existing application for PR201.

● **Parameter: Z (Error response)**

• **Function**

Returns an error response.

• **Command/response**

Number of bytes	1	2	1	2	2	1	1
Command element	STX	DG	Z	Station number (ADR)	Checksum	ETX	CR

There is no command data for data reading.

Number of bytes	1	2	1	2	2	2	1	1
Response element	STX	DG	Z	Station number (ADR)	□□	Checksum	ETX	CR

Response data is returned in a 2-byte ASCII character string.

• **Example**

Reads an error response of PR300 with station number 01. □□ indicates the checksum value.

[Command]

[STX]DGZ01□□[ETX][CR]

Returns a checksum error response for the above command.

[Response]

[STX]DGZ0180□□[ETX][CR]

Reads an error response by converting hexadecimal data “80” into binary data “10000000” and then reading the 7th bit (checksum error).

• **Bit information for error response**

Bit	Failure Status
0	Overranged power
1	Undefined
2	Undefined
3	Undefined
4	Undefined
5	Command data format error
6	Overranged command data
7	Checksum error

■ Command: DP

● Parameter: 0 (Reads setting value)

• Function

Reads the VT ratio, CT ratio and integrated low-cut power. The read low-cut power is always 0.

• Command/response

Number of bytes	1	2	1	2	2	1	1
Command element	STX	DP	0	Station number (ADR)	Checksum	ETX	CR

Number of bytes	1	2	1	2	6	6
Response element	STX	DP	0	Station number (ADR)	□□□□□□ (VT ratio)	□□□□□□ (CT ratio)

Response data is returned in a 16-byte ASCII character string.

Continued

4	2	1	1
□□.□ (Integrated low-cut power)	Checksum	ETX	CR

Response data to be returned for integrated low-cut power is always 0.

• Example

Reads the setting value of PR300 with station number 01. □□ indicates the checksum value.

[Command]

[STX]DP001□□[ETX][CR]

Returns a VT ratio of 10, a CT ratio of 100 and an integrated low-cut power of 0 for the above command.

[Response]

[STX]DP00100001000010000.0□□[ETX][CR]

● **Parameter: A (Remote reset)**

• **Function**

Performs remote reset. If remote reset is performed, the maximum value, minimum value, and instantaneous value of voltage and current are reset. If remote reset is performed at the start of optional integration, optional integration itself stops. Even if remote reset is performed, the data and parameter setting values of active energy remains unchanged.

• **Command/response**

Number of bytes	1	2	1	2	2	1	1
Command element	STX	DP	A	Station number (ADR)	Checksum	ETX	CR

Number of bytes	1	2	1	2	2	1	1
Response element	STX	DP	A	Station number (ADR)	Checksum	ETX	CR

There is no response data.

• **Example**

Performs remote reset on PR300 with station number 01. □□ indicates the checksum value.

[Command]

[STX]DPA01□□[ETX][CR]

Returns the following response for the above command.

[Response]

[STX]DPA01□□[ETX][CR]

Performs remote reset.



Because the PR300 microcomputer is reset after remote reset takes place, wait for 5 seconds or more before transmitting the next command.

● **Parameter: G (Integration reset)**

• **Function**

Resets the active energy.

• **Command/response**

Number of bytes	1	2	1	2	2	1	1
Command element	STX	DP	G	Station number (ADR)	Checksum	ETX	CR

Number of bytes	1	2	1	2	2	1	1
Response element	STX	DP	G	Station number (ADR)	Checksum	ETX	CR

There is no response data.

• **Example**

Resets the active energy of PR300 with station number 01. □□ indicates the checksum value.

[Command]

[STX] DPG01□□[ETX][CR]

Returns the following response for the above command.

[Response]

[STX] DPG01□□[ETX][CR]

Resets the active energy.

- **Parameter: 4 (Sets VT ratio), parameter: 5 (Sets CT ratio), parameter: B (Integrated low-cut power), parameter: C (Integration pulse unit), Parameter: D (Integration pulse ON pulse width), Parameter: E (Analog output scaling “L”), Parameter: F (Analog output scaling “H”) These parameters are not supported. Even if a command with any of these parameters is received, the command is disabled. The command is discarded and an error response (overranged command data error) is returned.**

Appendix Table of ASCII Codes (Alphanumeric Codes)

In order to implement PC link communication, create a transmission/receiving program by referring to the Table of ASCII Codes below.

Hex.	Dec.	Symbol	Hex.	Dec.	Symbol	Hex.	Dec.	Symbol	Hex.	Dec.	Symbol
00	0	^@ NUL	20	32	SPC	40	64	@	60	96	`
01	1	^A SOH	21	33	!	41	65	A	61	97	a
02	2	^B STX	22	34	"	42	66	B	62	98	b
03	3	^C ETX	23	35	#	43	67	C	63	99	c
04	4	^D EOT	24	36	\$	44	68	D	64	100	d
05	5	^E ENQ	25	37	%	45	69	E	65	101	e
06	6	^F ACK	26	38	&	46	70	F	66	102	f
07	7	^G BEL	27	39	'	47	71	G	67	103	g
08	8	^H BS	28	40	(48	72	H	68	104	h
09	9	^I HT	29	41)	49	73	I	69	105	i
0A	10	^J LF	2A	42	*	4A	74	J	6A	106	j
0B	11	^K VT	2B	43	+	4B	75	K	6B	107	k
0C	12	^L FF	2C	44	,	4C	76	L	6C	108	l
0D	13	^M CR	2D	45	-	4D	77	M	6D	109	m
0E	14	^N SO	2E	46	.	4E	78	N	6E	110	n
0F	15	^O SI	2F	47	/	4F	79	O	6F	111	o
10	16	^P DLE	30	48	0	50	80	P	70	112	p
11	17	^Q DC1	31	49	1	51	81	Q	71	113	q
12	18	^R DC2	32	50	2	52	82	R	72	114	r
13	19	^S DC3	33	51	3	53	83	S	73	115	s
14	20	^T DC4	34	52	4	54	84	T	74	116	t
15	21	^U NAK	35	53	5	55	85	U	75	117	u
16	22	^V SYN	36	54	6	56	86	V	76	118	v
17	23	^W ETB	37	55	7	57	87	W	77	119	w
18	24	^X CAN	38	56	8	58	88	X	78	120	x
19	25	^Y EM	39	57	9	59	89	Y	79	121	y
1A	26	^Z SUB	3A	58	:	5A	90	Z	7A	122	z
1B	27	^[ESC	3B	59	;	5B	91	[7B	123	{
1C	28 ^\	FS	3C	60	<	5C	92	\	7C	124	
1D	29	^] GS	3D	61	=	5D	93]	7D	125	}
1E	30	^^ RS	3E	62	>	5E	94	^	7E	126	~
1F	31	^_ US	3F	63	?	5F	95	_	7F	127	DEL

Revision Information

- Title : Model PR300
Power and Energy Meter Communication Interface User's Manual
(RS-485 and Ethernet Communications)
- Manual No. : IM77C01E01-10E

Apr. 2006/1st Edition

Newly published

Aug. 2006/2nd Edition

The PR201 original communication protocol is added.

Feb. 2007/3rd Edition

The note of the RS-232C/RS-485 converter is added.

June 2008/4th Edition

Error correction

Written by Yokogawa Electric Corporation

Published by Yokogawa Electric Corporation
2-9-32 Nakacho, Musashino-shi, Tokyo 180-8750, JAPAN



YOKOGAWA ELECTRIC CORPORATION**Headquarters**

2-9-32, Nakacho, Musashino-shi, Tokyo, 180-8750 JAPAN

Branch Sales Offices

Nagoya, Osaka, Hiroshima, Fukuoka, Sapporo, Sendai, Ichihara, Toyota, Kanazawa, Okayama, and Kitakyusyu.

YOKOGAWA CORPORATION OF AMERICA

2 Dart Road, Newnan, Georgia 30265-1094, U.S.A.

Phone : 1-800-888-6400

Fax : 1-770-254-0928

YOKOGAWA EUROPE B. V.

Databankweg 20 Amersfoort 3821 AL, THE NETHERLANDS

Phone : 31-33-464-1611 Fax : 31-33-464-1610

Branch Sales Offices / Wien (Austria), Zaventem (Belgium), Ratingen (Germany), Madrid (Spain), Runcorn (United Kingdom), Milano (Italy), Velizy-Villacoublay (France), Budapest (Hungary), Stockholm (Sweden), Sola (Norway), Warszawa (Poland), Vila Nova de Gaia (Portugal), Bucharest (Romania)

YOKOGAWA AMERICA DO SUL LTDA.

Praca Acapulco, 31 - Santo Amaro. Sao Paulo/SP - BRAZIL

Phone : 55-11-5681-2400 Fax : 55-11-5681-4434

YOKOGAWA ENGINEERING ASIA PTE. LTD.

5 Bedok South Road, 469270 SINGAPORE

Phone : 65-6241-9933 Fax : 65-6241-2606

YOKOGAWA ELECTRIC KOREA CO., LTD.

14-1, Yangpyongdong-4Ga, Youngdeungpo-Gu, Seoul, 150-866 KOREA

Phone : 82-2-2628-6000 Fax : 82-2-2628-6400

YOKOGAWA AUSTRALIA PTY. LTD.

Tower A, 112-118 Talavera Road, Macquarie Park,

N.S.W.2113, AUSTRALIA

Phone : 61-2-8870-1100 Fax : 61-2-8870-1111

YOKOGAWA INDIA LTD.

Plot No.96 Electronic City Complex, Hosur Road, Bangalore 560100, INDIA

Phone : 91-80-4158-6000 Fax : 91-80-2852-0625

YOKOGAWA CHINA CO., LTD.

Tangyue Pavilion, Xi'an software park No.72,

Keji 2nd Road Xi'an High-tech Industries Development Zone Xi'an 710075,

CHINA

Phone : 86-29-87669988 Fax : 86-29-87607800