

# Power Quality and Energy Efficiency for Power Measurements

# Table of Contents

Introduction . . . . .	.3
AC Power . . . . .	.3
Linear Versus Non-Linear Loads . . . . .	.3
Power Quality . . . . .	.4
What is Power Quality? . . . . .	.4
Causes of Poor Power Quality . . . . .	.5
Voltage Swell . . . . .	.5
Voltage Sag / Dip . . . . .	.5
Voltage Interruption / Dropout . . . . .	.5
Transient Overvoltage (Impulse) . . . . .	.5
Inrush Current . . . . .	.5
Flicker . . . . .	.5
Harmonics . . . . .	.5
Efficiency . . . . .	.6
Efficiency Measurements . . . . .	.6
DC/AC Inverter Efficiency. . . . .	.6
Filter Efficiency . . . . .	.6
Transformer Efficiency . . . . .	.6
System Efficiency . . . . .	.6
Harmonics . . . . .	.7
Triplen Harmonics . . . . .	.8
Calculating Harmonics . . . . .	.8
Total Harmonic Distortion. . . . .	.8
Total Demand Distortion (TDD) . . . . .	.8
Harmonics Measurements . . . . .	.9
Discrete Fourier Transform (DFT) . . . . .	.9
Fast Fourier Transform (FFT) . . . . .	.9
Resolution and Bandwidth . . . . .	.9
Harmonics Measurement Example . . . . .	10
Efficiency and Power Quality Standards . . . . .	10
IEEE 519 . . . . .	10
IEC 61000-3-2 (EN 61000-3-2). . . . .	10
IEC 61000-3-12 (EN 61000-3-12) . . . . .	10
IEC 61000-3-3 (EN 61000-3-3). . . . .	11
IEC 61000-3-11 (EN 61000-3-11) . . . . .	11
IEC 61000-4-7 (EN 61000-4-7). . . . .	11
IEC 62301 . . . . .	11
MIL-STD-704 . . . . .	11
DO-160 . . . . .	11
MIL-STD-1399 . . . . .	11
ANSI/AHRI Standard 210/240-2008 . . . . .	11
Putting It All Together . . . . .	12
Conclusion . . . . .	12

# Power Quality and Energy Efficiency for Power Measurements

## Introduction

Global environmental market forces considerably impact how products are manufactured. Affordable, clean energy is a [sustainable development goal](#) intended to drive more efficiency in our products today.

More than [40 percent](#) of the total energy consumed in the United States is used to operate buildings, and most of that energy is consumed by appliances and building-related equipment. The U.S. Department of Energy (DOE) implements minimum efficiency standards for a wide range of appliances and equipment used in residential and commercial buildings. Currently, DOE efficiency standards cover more than 60 categories of products. In 2015, these standards helped to reduce our national energy bill by \$80B, the equivalent of the electricity needs of nearly one in three American households.

The objective of this paper is to show the close relationship between efficiency and power quality, and provide education on the causes of power quality, types of power quality issues, and provide guidance on measurement considerations.

## AC Power

Typically, electrical power is distributed as a sinusoidal voltage produced by an electro-mechanical generation source. When electric current flows through a wire or conductor, a circular magnetic field is created around the wire and whose strength is related to the current value. When a single wire moves through a permanent magnetic field, an electromagnetic field (EMF) is induced. This creates an instantaneous voltage that depends upon the rate or speed ( $\omega$  in Figure 1) at which the coil is rotated and on the angle of rotation ( $\theta$  in Figure 1).

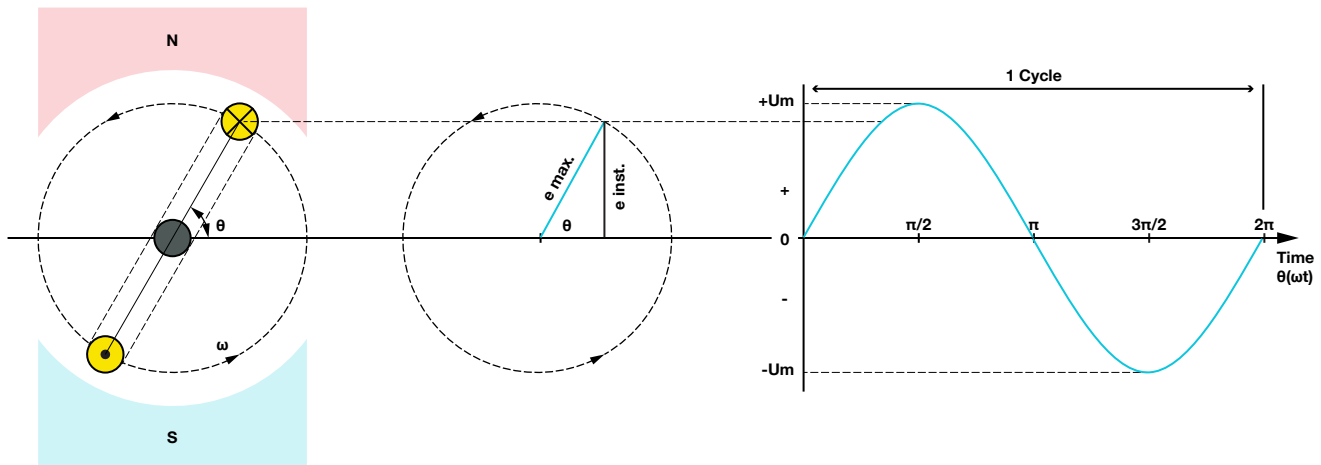

Figure 1 - A wire moving through a permanent magnet creates an instantaneous voltage

## Linear Versus Non-Linear Loads

When an electrical load is connected to a voltage source, it draws current to perform work. If the current follows in the same sinusoidal pattern as the voltage, then the load is said to linearly follow the voltage and is referred to as a linear load.

When a sine wave voltage is applied to a load of linear elements such as a resistor, inductor, or capacitor, the current will always be a sine wave of the same frequency and waveshape, but with a phase shift.

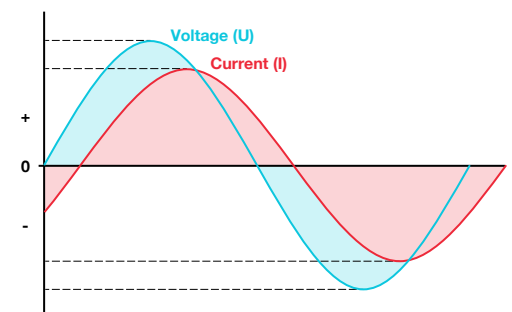

Figure 2 - Voltage and current waveform in a linear load

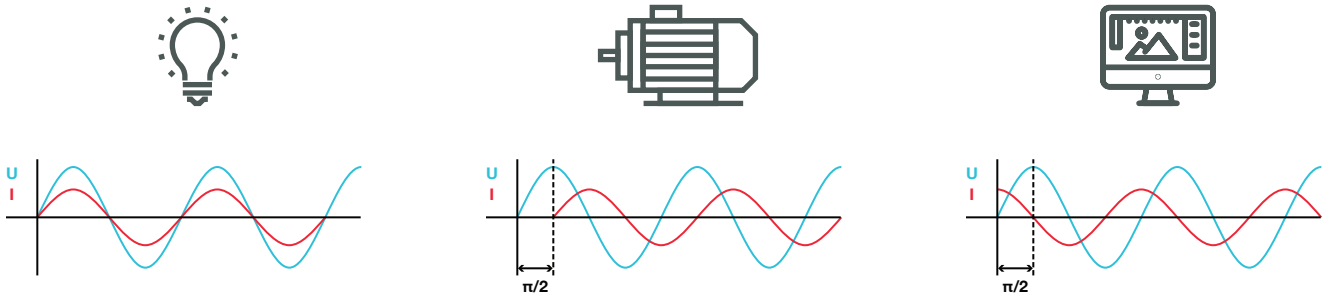

Figure 3 - Three linear load examples - a light bulb is a resistive load, a motor is an inductive load, and a monitor is a capacitive load

However, if the connected load does not follow the sinusoidal wave shape of the voltage, then it is referred to as a non-linear load. Non-linear loads cause stress on the transformers and generators that make up the power system. This stress has been found to be primarily thermal in nature. Since power systems carrying non-linear loads are less efficient, it is important to identify them and take corrective action to reduce their negative impacts on the power grid.

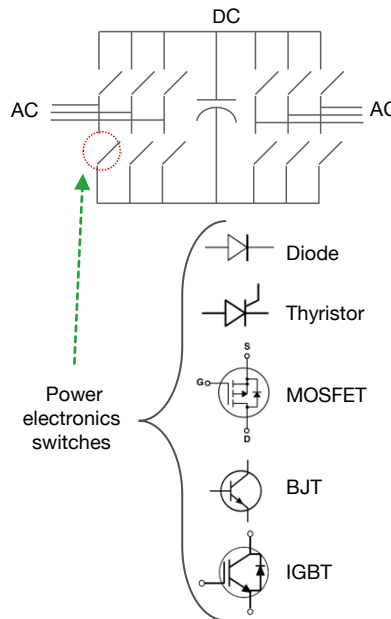

Figure 4 - A non-linear load such as a drive system uses non-linear devices to convert DC to AC using PWM techniques

## Power Quality

Power quality is the measure of the deviation from the normal sine wave from which the power source was generated. Due to the increasing use of non-linear devices in power systems, poor power quality is becoming an increasing cause of concern for consumers and generators of electrical power.

From an engineer’s perspective, poor power quality causes excess heat in electrical equipment such as motors and transformers, causes inefficient operation due to wasted reactive power, and can potentially damage equipment, often due to unbalanced loads and high neutral currents.

From a business perspective, poor power quality increases costs due to inefficient reactive power, increases operations expenses (OPEX) due to higher maintenance and replacement costs of damaged equipment, and reduces system capacity.

## What is Power Quality?

Power quality depends on compatibility between the power source and the load. From a consumer’s perspective, poor power quality is an incompatibility that has an adverse effect on the grid or generation source. From a power generator’s perspective, power quality depends on how clean the output power is and its compatibility with the load.

## Causes of Poor Power Quality

Poor power quality manifests itself through various phenomena. The measure of the following phenomena can help professionals understand potential issues with power systems and provide insight into mitigation techniques.

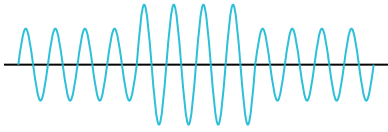

### Voltage Swell

Voltage swell is defined as the increase in the rms voltage level to 110% - 180% of nominal, at the power frequency of ½ cycle to one minute. These are caused by lightning or heavy load switching on power lines.

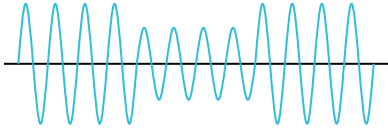

### Voltage Sag / Dip

A voltage sag or dip is defined by IEEE 1159 as the decrease in the rms voltage level to 10% - 90% of nominal, at the power frequency for durations of ½ cycle to one minute. Generating moments on motor loads, weather, and utility equipment problems could cause an inrush current and dips in voltage.



### Voltage Interruption / Dropout

A voltage dropout includes both severe rms voltage sags and complete interruptions of the applied voltage, followed by immediate re-application of the nominal voltage. Momentary or long power disruptions are often caused by lightning or open breakers.

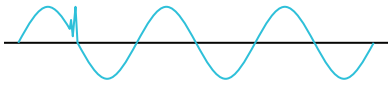

### Transient Overvoltage (Impulse)

Transients are power quality disturbances that involve destructive high magnitudes of current, voltage, or both. Lightning or heavy load switching on a power line may cause a momentary change on voltage.

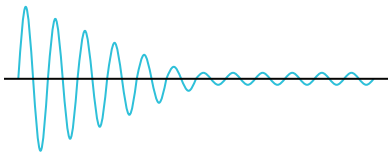

### Inrush Current

Inrush current is defined as the maximum instantaneous input current drawn by an electrical device when first turned on. Generating moments on a motor load may cause an inrush current as well as capacitor discharge in power convertor systems.

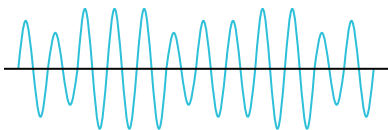

### Flicker

Flicker is generally limited to lighting applications and is described as systematic variations of the voltage waveform envelope, or a series of random voltage changes, the magnitude of which falls between the voltage limits set by ANSI C84.1. Flicker manifests itself with variations in light output.

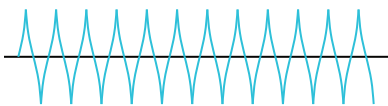

### Harmonics

Harmonics are described by IEEE as sinusoidal voltages or currents with frequencies that are integer multiples of the fundamental frequency. Harmonics are generally caused by non-linear loads on the power system.

## Efficiency

Recent innovations, like PWM motor control and switched mode power supplies, are designed to improve efficiency. Unfortunately, they also introduce non-linear elements that create power quality issues and cause the problems they are intended to fix. Calculating how much poor power quality phenomena affect product performance involves measuring energy efficiency.

### Efficiency Measurements

Efficiency is defined as the power output divided by the power input. An efficiency of 100% is desired but not practical due to losses and distortions in common power systems, as illustrated in the power quality section above.

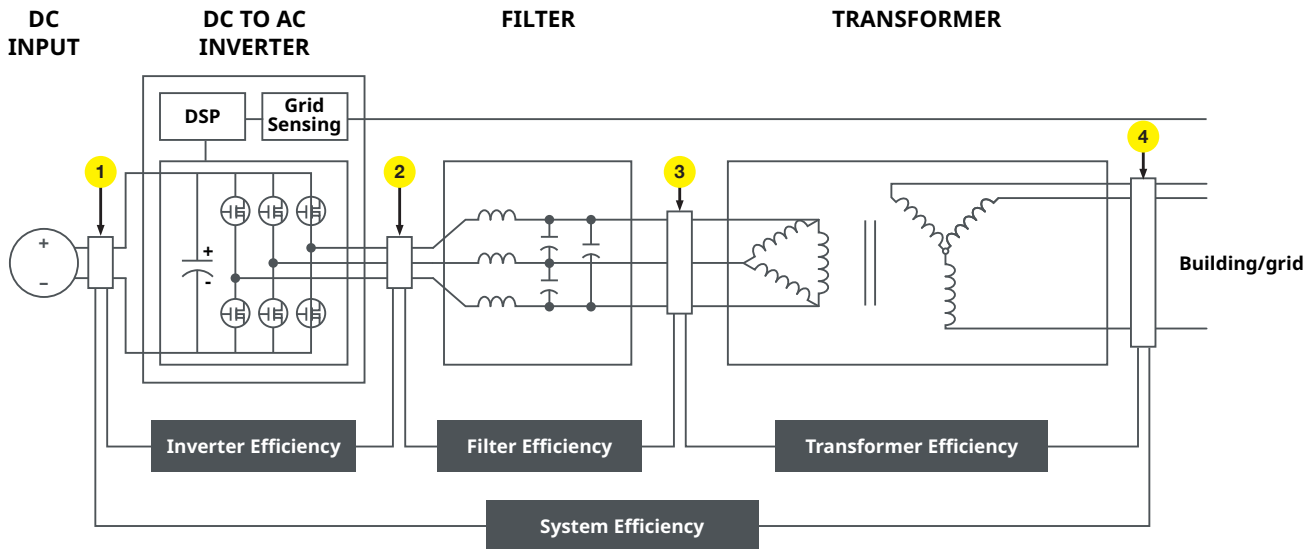

Figure 5 - An energy conversion system for a solar panel connected to the grid has multiple efficiency measurement points

Figure 5 illustrates an example of efficiency measurements in a solar energy system. In this example, the DC input is converted to AC through an inverter, filtered, and regulated with a step-up transformer for input to a grid system.

The following equations indicate how and where efficiency measurements are taken within the system.

$$\eta = \frac{\sum P_2}{P_1}$$

#### DC/AC Inverter Efficiency

DC/AC inverters inevitably introduce highly distorted input current, which result in serious current harmonics and a low power factor.

$$\eta = \frac{\sum P_3}{\sum P_2}$$

#### Filter Efficiency

The filter consists of linear devices, which should not impact harmonics, but phase shift can alter power and ultimately energy efficiency over time. A THD measurement is important to characterize the PWM filter and ensure its specified efficiency is being met.

$$\eta = \frac{\sum P_4}{\sum P_3}$$

#### Transformer Efficiency

Losses in a transformer include copper loss due to ohmic resistance of the windings, iron loss from eddy current, and hysteresis loss.

$$\eta = \frac{\sum P_4}{P_1}$$

#### System Efficiency

System efficiency depends on the load, which, in this case, is a building. The numerous components all contribute some loss to the overall system. Characterizing the complete system is an important measurement. It is also important to note that full characterization includes a long time period to consider the energy (Watt-hours or Joules) as opposed to a power reading with shorter time duration. Ultimately, it is the energy efficiency that needs to be measured.

## Harmonics

A common contributor to poor power quality in most power systems is harmonics.

Harmonics are defined as voltages or currents that operate at frequencies that are integral (whole number) multiples of the fundamental frequency. A resultant waveform is the sum of multiple sine waves that have different frequencies. The fundamental waveform can be called a first harmonic waveform. A second harmonic has a frequency twice that of the fundamental, the third harmonic has a frequency three times the fundamental, and so forth.

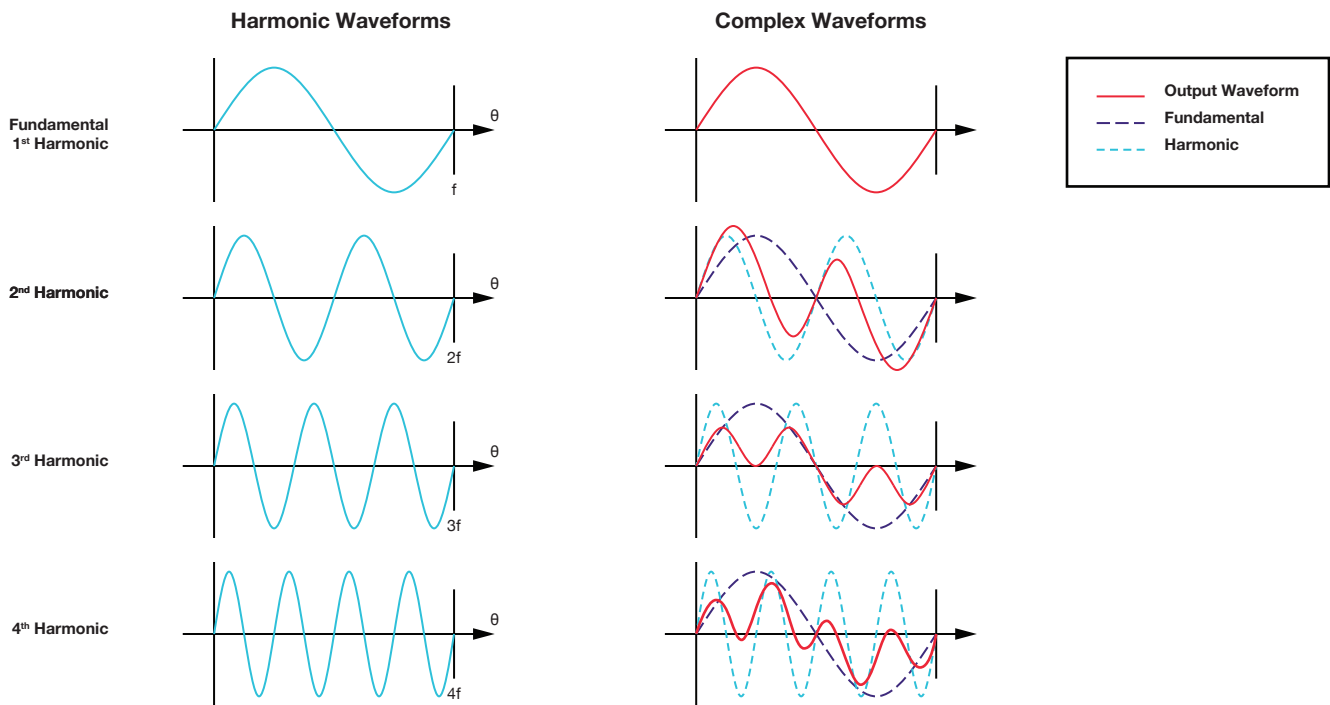

Figure 6 - Harmonics consist of multiple frequencies at integer multiples of the fundamental

In Figure 6, the red waveforms are the actual shapes of the waveforms as seen by a load due to harmonic content being added to the fundamental frequency. Theoretically, there are both even and odd-numbered harmonics. Typically, in an AC power system, even harmonics are absent. The causes for concern are the odd harmonics which are present in an AC system and their contribution to total harmonic distortion.

Harmonics are generally classified by their name, frequency, and sequence. In the table below, the 3rd harmonic is 150 Hz and a 0 sequence. Harmonic sequence refers to the phasor rotation of the harmonic voltages and currents with respect to the fundamental waveform in a balanced three-phase, four-wire motor.

We can summarize the sequence effects as multiples of the fundamental frequency of 50 Hz as shown in the following table.

Name	Fund.	2nd	3rd	4th	5th	6th	7th	8th	9th
Frequency, Hz	50	100	150	200	250	300	350	400	450
Sequence	+	-	0	+	-	0	+	-	0

Table 1 - Sequence effects as multiples of the fundamental frequency

A positive sequence harmonic (fourth, seventh, tenth, etc.) would rotate in the same direction (forward) as the fundamental frequency, whereas a negative sequence harmonic (second, fifth, eighth, etc.) rotates in the opposite direction (reverse) of the fundamental frequency.

It is important to note that most harmonic currents found in a distribution system are odd order harmonics (third, fifth, seventh).

Generally, positive sequence harmonics are undesirable because they are responsible for overheating of conductors, power lines, and transformers due to the addition of the waveforms.

Sequence	Rotation	Harmonic Effect
+	Forward	Excessive Heating Effect
-	Reverse	Motor Torque Problems
0	None	Adds Voltages and/or Currents in Neutral Wire Causing Heating

Table 2 - The harmonic sequence type has different effects on the load or system

Negative sequence harmonics, on the other hand, circulate between the phases and create additional problems with motors. The opposite phasor rotation weakens the rotating magnetic field required by motors (especially induction motors), resulting in reduced mechanical torque.

### Triplen Harmonics

Another type of special harmonics, triplen, has a zero rotational sequence. Triplens are multiples of the third harmonic (third, ninth, fifteenth, etc.), hence their name, and are, therefore, displaced by zero degrees. Zero sequence harmonics circulate between the phase and neutral (or ground).

Unlike the positive and negative sequence harmonic currents that cancel each other out, third order or triplen harmonics do not cancel out. Instead, they add up arithmetically in the common neutral wire, which is subjected to currents from all three phases. The result is that current amplitude in the neutral wire could be up to three times the amplitude of the phase current at the fundamental frequency. That can cause it to become less efficient and overheat.

## Calculating Harmonics

An effective way to calculate the impact of harmonics on a power system is to calculate the total harmonic distortion (THD) and total demand distortion (TDD). While these measurements are often standard features in test equipment, it is important to understand how and why they are calculated.

### Total Harmonic Distortion

THD is the ratio of the rms of the harmonic content, expressed as a percentage of the fundamental or total. It considers harmonic components up to the 50th order but specifically excludes interharmonics. Harmonic components of orders greater than 50 may be included when necessary. The higher the percentage, the more distorted the waveform.

The THD equation as defined by CSA includes all harmonics in the denominator.

$$I_{THD}(\%) : \frac{\sqrt{\sum_{k=2}^{max} I(k)^2}}{I(total)} \times 100$$

The THD equation as defined by IEC includes only the fundamental harmonic in the denominator.

$$I_{THD}(\%) : \frac{\sqrt{\sum_{k=2}^{max} I(k)^2}}{I(1)} \times 100$$

### Total Demand Distortion (TDD)

TDD is the ratio of the rms of the harmonic content, expressed as a percentage of the maximum demand current. It considers harmonic components up to the 50th order but specifically excludes interharmonics. Harmonic components of order greater than 50 may be included when necessary. TDD is a moving average of the THD based on system-rated current value. The difference between the TDD equation and the THD equation is the denominator,  $I_L$ .  $I_L$  equals the sum of all currents corresponding to maximum demand during each of the twelve previous months, divided by 12.

$$I_{TDD} : \frac{\sqrt{\sum_{k=2}^{max} I(k)^2}}{I_L}$$



## Harmonics Measurements

There are two methods for measuring harmonics: the discrete Fourier transform and the fast Fourier transform.

### Discrete Fourier Transform (DFT)

A DFT converts a finite sequence of equally spaced samples of a function into a same-length sequence of equally spaced samples of the discrete time Fourier transform (DTFT), which is a complex-valued function of frequency. The DFT is therefore said to be a frequency domain representation of the original input sequence.

### Fast Fourier Transform (FFT)

A FFT is a computational algorithm that reduces the computing time and complexity of large transforms, and is simply an algorithm used for fast computation of the DFT.

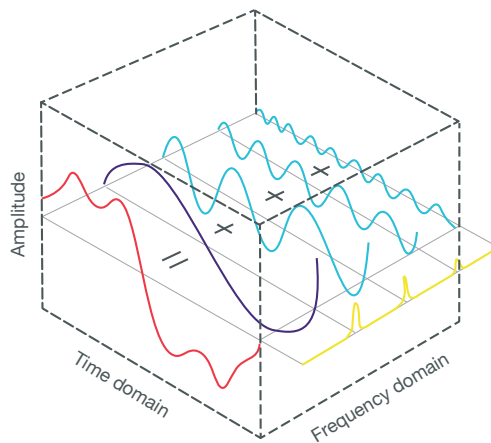

Figure 7 - Fourier states that a complex waveform could be understood and mathematically defined as a composite of a fundamental frequency with other sine waves in multiples of that frequency

By applying a Fourier transform, we can break down a complex waveform into its basic components, which happen to be sine waves at various frequencies, amplitudes, and phases.

### Resolution and Bandwidth

Frequency resolution is the distance in Hz between two adjacent data points in the DFT. The resolution of a FFT is defined as the sampling rate divided by the number of data points. Sampling rate determines the bandwidth of the FFT, so as sampling rate increases, so does the bandwidth. The higher the sampling speed, the lower the FFT resolution.

$$\text{Frequency Resolution} = \frac{f_s}{N}$$

$$\text{Bandwidth} = \frac{f_s}{2}$$

$N = \text{number of sample}$   
 $f_s = \text{sampling rate (S/s)}$

An example is 10 MS/s and 10 kpts = 10,000,000 / 10,000 = 1,000 Hz or 1 kHz. Increasing the memory depth results in slower computation.

$$\text{Frequency Resolution} = \frac{10 \text{ MS/s}}{10 \text{ kPts}} = 1,000 \text{ Hz}$$

$$\text{Bandwidth} = \frac{10 \text{ MS/s}}{2} = 5 \text{ MHz}$$

## Harmonics Measurement Example

Using the previous solar DC/AC converter example, Figure 8 shows the DC input transformation as it is ultimately converted to an AC waveform through PWM. The rectified stages create harmonics, which lead to losses. These harmonic distortions can manifest themselves onto the grid and impact other systems. Measuring the THD of the filter output becomes an important measurement to prevent any power quality issues being amplified through the transformer stage.

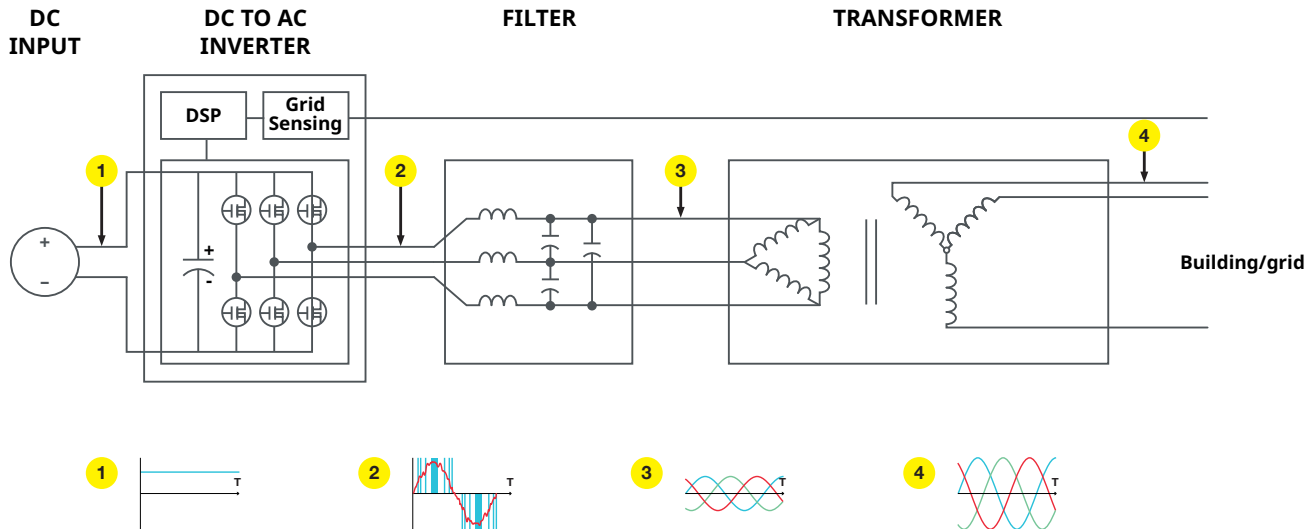

Figure 8 - The DC to AC converter system creates harmonics in the inverter system due to non-linear components

## Efficiency and Power Quality Standards

Power quality standards provide guidance on acceptable distortion values, industry accepted terminology, measurement test points, and test limits. Standard bodies are often non-profit associations made up of manufacturers, energy experts, consumer advocates, and other stakeholders who seek to align various industries to a testing and production norm. There are hundreds of standards that are specific to industries and markets. When a new standard is placed into production, regulators have the right to restrict sale or use of non-compliant products. Through adherence to test standards, both producers and consumers aim to gain cost savings, energy savings, energy security, emissions reductions, and technological innovations.

The following are a few standards that define efficiency and power quality, spanning appliances, industrial, HVAC, and Mil/Aero industries.

### IEEE 519

The IEEE 519 standard is from the Institute of Electrical and Electronics Engineers, which is a non-profit professional association dedicated to advancing technological innovation to electricity. The specific IEEE 519 standard that addresses harmonics is commonly referred to as IEEE 519-2014 and details the recommended practices and requirements regarding harmonic control in electrical power systems.

### IEC 61000-3-2 (EN 61000-3-2)

International standard IEC 61000-3-2 aims to set limits to the harmonic currents drawn by electrical apparatus and maintain mains voltage quality. Version 3-2 is specific to measuring the harmonics of equipment with a current of 16A or below.

### IEC 61000-3-12 (EN 61000-3-12)

International standard IEC 61000-3-12 aims to set limits to the harmonic currents drawn by electrical apparatus and so maintain mains voltage quality. Version 3-2 is specific to measuring the harmonics of equipment with a current above 16A but not greater than 75A.

### IEC 61000-3-3 (EN 61000-3-3)

International standard IEC 61000-3-3 sets limits of voltage changes, voltage fluctuations, and flicker in public low-voltage supply systems for equipment with rated current  $\leq 16A$ .

### IEC 61000-3-11 (EN 61000-3-11)

International standard IEC 61000-3-3 sets limits of voltage changes, voltage fluctuations, and flicker in public low-voltage supply systems for equipment with rated current  $> 16A$  and  $\leq 75A$ .

### IEC 61000-4-7 (EN 61000-4-7)

International standard IEC 61000-4-7 applies to instrumentation intended for measuring spectral components in the frequency range up to 9 kHz which are superimposed on the fundamental of the power supply systems at 50 and 60 Hz.

### IEC 62301

The International Electrotechnical Commission (IEC) 62301 test procedure describes a method for measuring standby power use in appliances, also referred to as vampire power. This is more commonly known as “Energy Star.” The label implies above average energy performance and is typically used for residential products.



### MIL-STD-704

The MIL-STD-704 defines the standardized power interface between a military aircraft and its equipment and carriage stores, covering such topics as voltage, frequency, phase, power factor, ripple, maximum current, electrical noise, and abnormal conditions (overvoltage and undervoltage) for both AC and DC systems.

### DO-160

DO-160 is a standard for environmental testing of avionics published by the American Radio Technical Commission for Aeronautics (RTCA). The specific test that concerns power quality is the RF emission and susceptibility, defined in sections 20 and 21 of the standards.

### MIL-STD-1399

MIL-STD-1399, section 300, sets out standards for the use of AC power on military shipboard environments.

### ANSI/AHRI Standard 210/240-2008

ANSI/AHRI defines a regional standard for seasonal energy efficiency ratio (SEER). SEER is focused on the HVACR market and determines the ratio of total cooling during normal periods of operation divided by total electric energy input during the same period.

Additionally, it defines the heating performance factor (HSPF) to measure heat pump efficiency in heating mode, as opposed to SEER, which measures heat pump efficiency in cooling mode.

## Putting It All Together

While the number of power standards is in the many hundreds, those listed in Table 3 represent a more common requirement in industry today. Each standard exists for an industry and the test limits and requirements vary for each. The table below generalizes how energy efficiency and power quality relate to compliance.







Industry/Market	Standard Compliance	Energy		Harmonic Distortion Power Quality						Transient Capture			
		Consumption/Production (Wh)	Efficiency (%)	Harmonics/THD	Electromagnetic Compatibility (EMC)	Voltage Swell	Voltage Dip/Sag	Voltage Interruption	Flicker	Transient Overvoltage	In-Rush Current	Voltage Ripple	Current Spectrum
 Appliances	IEC62301 (Energy Star)	✓	✓										
	EN 50564: 2011 (standby power)	✓	✓	✓									
 Power Generation/ Grid Tied	UL1741SA			✓							✓		
	IEC 61000-4-7			✓									
	IEC/EN 61000-3-2			✓									
	IEC/EN 61000-3-12			✓									
 Industrial	IEEE519-2014			✓									
	IEC 60034-30-2	✓	✓										
 Mil/Aero	MIL-STD-704			✓							✓		✓
	MIL-STD-1399							✓		✓	✓	✓	
	DO-160			✓				✓		✓			
 HVAC	DOE-STD-1153-2002 /M1	✓	✓								✓		
	ANSI/AHRI 210/240-2008	✓	✓										
 Lighting	IEC/EN 61000-3-3				✓	✓	✓	✓	✓	✓			
	IEC/EN 61000-3-11				✓	✓	✓	✓	✓	✓			
	IEC/EN 61000-4-15				✓	✓	✓	✓	✓	✓			
	ANSI/IES LM-79-19	✓	✓										

Table 3 - Industry standards require specific measurements

## Conclusion

Harmonics are more prevalent in modern electrical systems due to the rising use of non-linear devices to control power. Because of the detrimental effects on motors, transformers, switch gear, fuses, and other devices, it is becoming more important to accurately measure and quantify harmonic orders to not only determine compliance with systems and standards, but to assist in the mitigation to reduce the harmful effects.

Oscilloscopes and power analyzers are capable of measuring harmonics, however selecting the right instrument depends on the application, standard, and other important details.

