





## ■ Power Supply Specifications and Isolation

- Power supply:
  - Rated voltage: 100-240 V AC (+10%/-15%), 50/60 Hz
  - 24 V AC/DC (+10%/-15%) (for /DC option)
- Power consumption:
  - UP35A: 18 VA (DC:9 VA, AC: 14 VA if /DC option is specified)
  - UP32A: 15 VA (DC:7 VA, AC: 11 VA if /DC option is specified)
- Data backup: Nonvolatile memory
- Power holdup time: 20 ms (for 100 V AC drive)
- Withstanding voltage
  - Between primary terminals and secondary terminals: 2300 V AC for 1 minute (UL, CSA)
  - Between primary terminals and secondary terminals: 3000 V AC for 1 minute (CE)
  - Between primary terminals: 1500 V AC for 1 minute
  - Between secondary terminals: 500 V AC for 1 minute
  - (Primary terminals: Power\* and relay output terminals; Secondary terminals: Analog I/O signal terminals, contact input terminals, communication terminals and functional grounding terminals.)
  - \*: Power terminals for 24V AC/DC models are the secondary terminals.
- Insulation resistance: Between power supply terminals and a grounding terminal 20 MΩ or more at 500 V DC
- Isolation specifications

PV (universal ) input terminals	Internal circuits	Power supply
Control, retransmission (analog) output terminals (not isolated between the analog output terminals)		
Valve position (feedback) input terminals		
Control relay (contact point c/contact point a x 2) output terminals		
PV event-1 relay (contact point a) output terminals		
PV event-2 relay (contact point a) output terminals		
Time event-1 relay (contact point a) output terminals		
Position proportional relay output terminals		
Contact input terminals (all)		
RS-485 communication terminals		
24 V DC loop power supply terminals		
Contact output (transistor) terminals		
Ethernet communication terminal		
PROFIBUS-DP/DeviceNet/CC-Link communication terminals		
Current transformer input terminals		

The circuits divided by lines are insulated mutually.

## ■ Environmental Conditions

### Normal Operating Conditions:

- Ambient temperature: -10 to 50°C (side-by-side mounting: -10 to 40 °C)
- If the CC-Link option is specified, 0 to 50 °C for UP35A; 0 to 40 °C for UP32A. (side-by-side mounting: 0 to 40 °C for UP35A/UP32A with CC-Link option)
- Ambient humidity: 20 to 90% RH (no condensation allowed)
- Magnetic field: 400 A/m or less
- Continuous vibration at 5 to 9 Hz: Half amplitude of 1.5 mm or less, 1oct/min for 90 minutes each in the three axis directions
- Continuous vibration at 9 to 150 Hz: 4.9 m/s<sup>2</sup> or less, 1oct/min for 90 minutes each in the three axis directions
- Short-period vibration: 14.7 m/s<sup>2</sup>, 15 seconds or less
- Shock: 98 m/s<sup>2</sup> or less, 11 ms
- Altitude: 2000 m or less above sea level
- Warm-up time: 30 minutes or more after the power is turned on
- Startup time: Within 10 seconds
- \*: The LCD (a liquid crystal display) is used for a display portion of this product. The LCD has a characteristic that the display action becomes late at the low temperature. However, the control function is not affected.

### Transportation and Storage Conditions:

- Temperature: -25 to 70°C
- Temperature change rate: 20°C/h or less
- Humidity: 5 to 95% RH (no condensation allowed)

### Effects of Operating Conditions

- Effect of ambient temperature:
  - Voltage or TC input: ±1 μV/°C or ±0.01% of F.S./°C, whichever is larger
  - Current input: ±0.01% of F.S./°C
  - RTD input: ±0.05°C/°C (ambient temperature) or less
  - Analog output: ±0.02% of F.S./°C or less
- Effect of power supply voltage fluctuation
  - Analog input: ±0.05% of F.S. or less
  - Analog output: ±0.05% of F.S. or less (Each within rated voltage range)

## 5. How to Connect Wires



- Wiring work must be carried out by a person with basic electrical knowledge and practical experience.
- Be sure to turn OFF the power supply to the controller before wiring to avoid an electric shock. Use a tester or similar device to ensure that no power is being supplied to a cable to be connected.
- For the wiring cable, the temperature rating is 75 °C or more.
- As a safety measure, always install a circuit breaker (an IEC 60947-compatible product, 5 A, 100 V or 220 V AC) in an easily accessible location near the instrument. Moreover, provide indication that the switch is a device for turning off the power to the instrument.
- Install the power cable keeping a distance of more than 1 cm from other signal wires.
- The power cable is required to meet the IEC standards concerned or the requirements of the area in which the instrument is being installed.
- Wiring should be installed to conform to NEC (National Electrical Code: ANSI/NFPA-70) or the wiring construction standards in countries or regions where wiring will be installed.
- Since the insulation provided to each relay output terminal is functional insulation, provide Reinforced insulation to the external of the device as necessary. (Refer to the drawing below.)

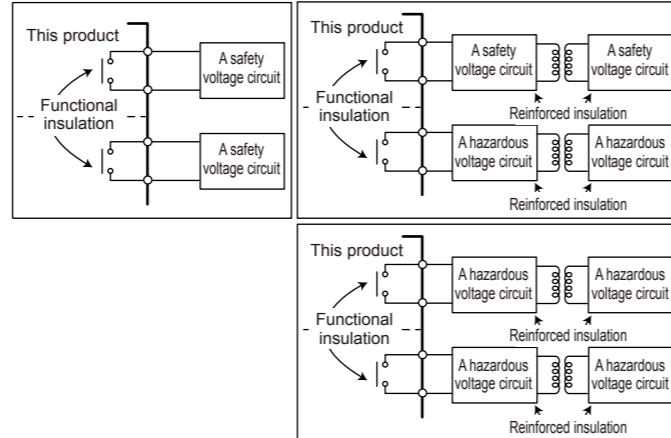

- When connecting two or more crimp-on terminal lugs to the single terminal block, bend the crimp-on terminal lugs as shown in the figure before tightening the screw.
- Note that the wiring of two or more crimp-on terminal lugs to the single high-voltage terminal of the power supply and relay, etc. does not comply with the safety standard.



- Provide electricity from a single-phase power supply. If the power is noisy, install an isolation transformer on the primary side, and use a line filter on the secondary side. When measures against noise are taken, do not install the primary and secondary power cables close to each other.
- If there is a risk of external lightning surges, use a lightning arrester etc.
- For TC input, use shielded compensating lead wires for wiring. For RTD input, use shielded wires that have low conductor resistance and cause no significant differences in resistance between the three wires.
- Since the control output relay has a life span (resistance load of 100,000 times), use the auxiliary relay to perform ON/OFF control.
- The use of inductance (L) loads such as auxiliary relays, motors and solenoid valves causes malfunction or relay failure; always insert a CR filter for use with alternating current or a diode for use with direct current, as a spark-removal surge suppression circuit, into the line in parallel with the load.
- After completing the wiring, the terminal cover is recommended to use for the instrument.

### ● Recommended Crimp-on Terminal Lugs

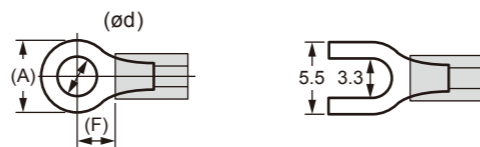

Recommended tightening torque: 0.6 N·m  
Applicable wire size: Power supply wiring 1.25 mm<sup>2</sup> or more

Applicable terminal lug	Applicable wire size mm <sup>2</sup> (AWG#)	(φ d)	(A)	(F)
M3	0.25 to 1.65 (22 to 16)	3.3	5.5	4.2

## ● Cable Specifications and Recommended Cables

Purpose	Name and Manufacturer
Power supply, relay contact outputs	600 V Grade heat-resistant PVC insulated wires, JIS C 3317(HIV), 0.9 to 2.0 mm <sup>2</sup>
Thermocouple	Shielded compensating lead wires, JIS C 1610 For thermocouple input (PV input and remote input with direct input), shielded compensating lead wire of cross-sectional area less than or equal to 0.75 mm <sup>2</sup> is recommended. If the cross-sectional area is wide, the reference junction compensation error may be large.
RTD	Shielded wires (three/four conductors), UL2482 (Hitachi Cable)
Other signals (other than contact input/output)	Shielded wires
Other signals (contact input/output)	Unshielded wires
RS-485 communication	Shielded wires
Ethernet communication	100 BASE-TX (CAT-5)/10 BASE-T
PROFIBUS-DP communication	Dedicated cable for PROFIBUS-DP (Shielded two-wires)
DeviceNet communication	Dedicated cable for DeviceNet (Shielded five-wires)
CC-Link communication	Dedicated cable for CC-Link (Shielded three-wires)

PROFIBUS-DP/CC-Link Connector (wiring side) (Part number: A1987JT)

DeviceNet Connector (wiring side) (Part number: L4502BW)

Recommended tightening torque: 0.5 to 0.6 N·m

## Transistor Output Wiring

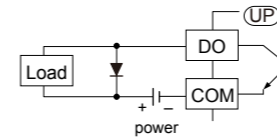

## 6. Terminal Wiring Diagrams



- Do not use an unassigned terminal as the relay terminal.
- Do not use a 100-240 V AC power supply for the 24 V AC/DC model; otherwise, the instrument will malfunction.

### ■ UP35A

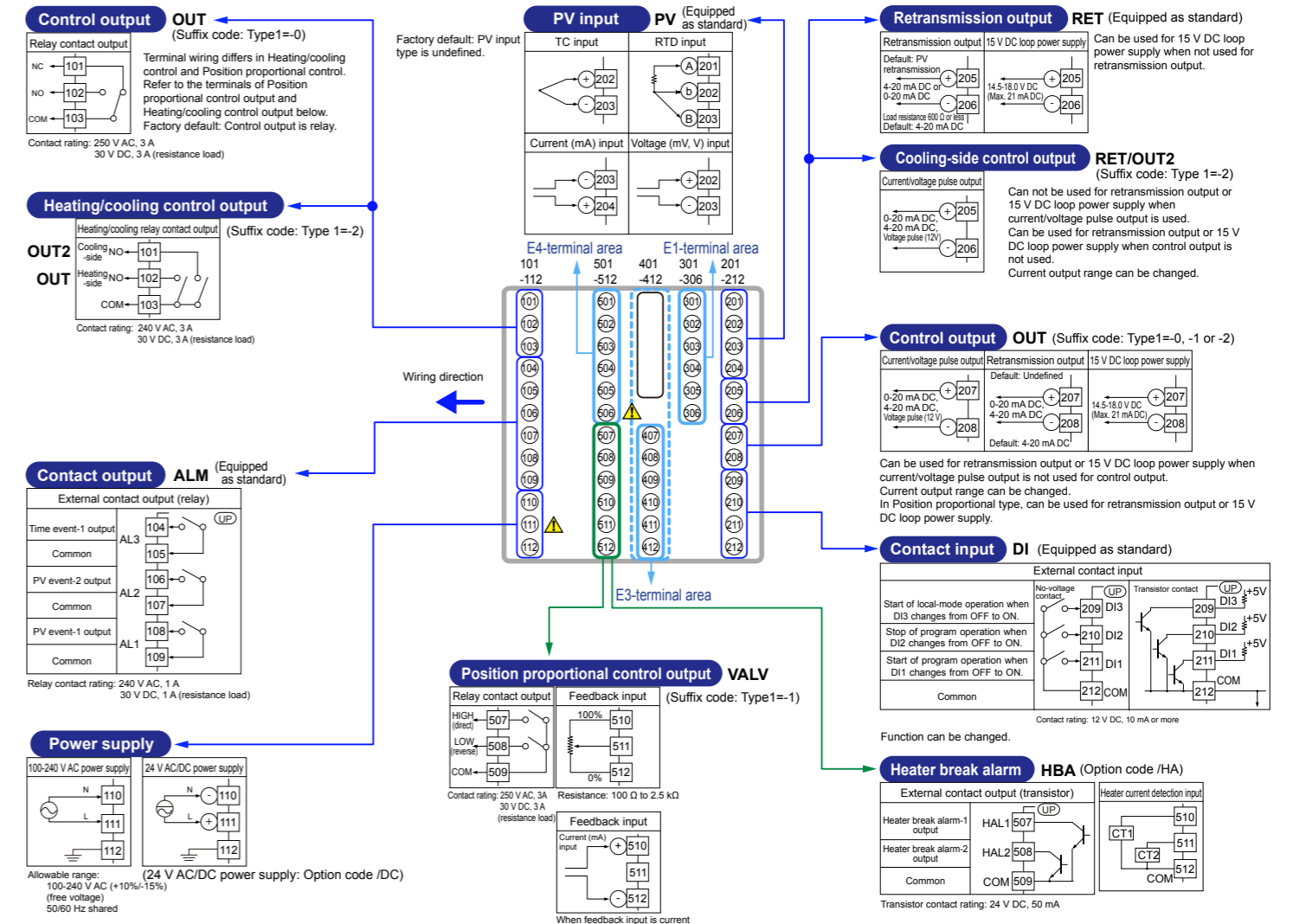

### DC Relay Wiring

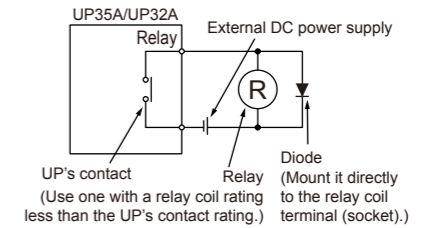

### AC Relay Wiring

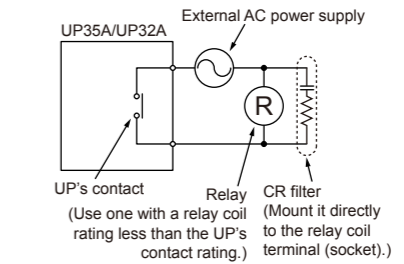

■ UP35A (Continued from page 3)

E4-terminal area E1-terminal area

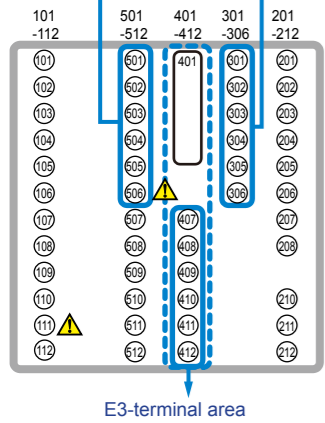

301-306 E1-Terminal Area

Contact output DO (Suffix code: Type 2=1)

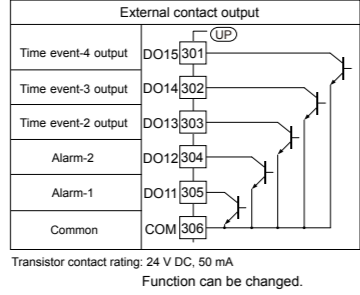

Transistor contact rating: 24 V DC, 50 mA  
Function can be changed.

501-506 E4-Terminal Area

Contact input DI (Suffix code: Type 2=1)

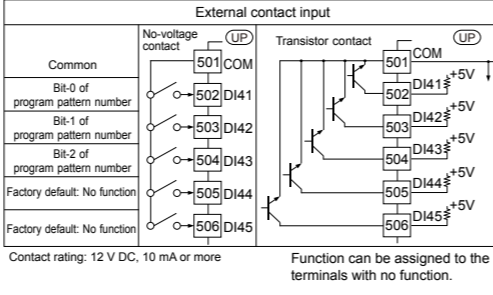

Contact rating: 12 V DC, 10 mA or more  
Function can be assigned to the terminals with no function.

Program patterns can be selected according to the combination of ON and OFF contact inputs.

Program pattern no.	1	2	3	4
DI41	ON	OFF	ON	OFF
DI42	OFF	ON	ON	OFF
DI43	OFF	OFF	OFF	ON

401-412 E3-Terminal Area

RS-485 communication RS485

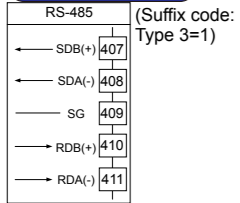

Ethernet communication (with gateway function) ETHR

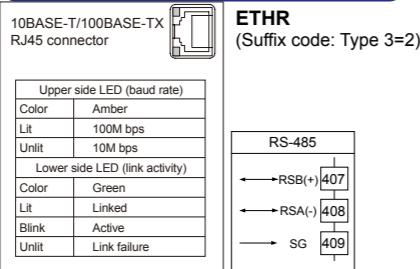

PROFIBUS-DP communication (with Modbus master) PROF

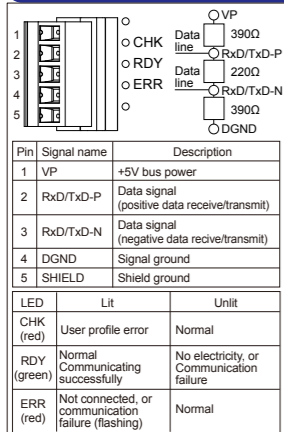

PROF (Suffix code: Type 3=4)  
If the UT is located at the end of a segment for the PROFIBUS communication wiring, terminating resistors are separately needed. These are to be prepared by users. (390 Ω: 2 pcs. 220 Ω: 1 pc., or an active terminator.)

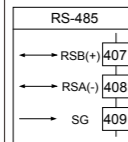

DeviceNet communication (with Modbus master) DNET

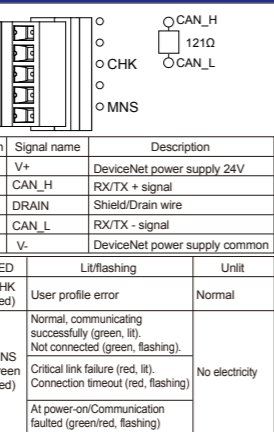

DNET (Suffix code: Type 3=5)  
If the UT is located at the end of a segment for the DeviceNet communication wiring, terminating resistors are separately needed. These are to be prepared by users. (121 Ω: 1 pc.)

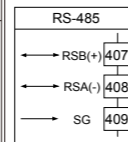

CC-Link communication (with Modbus master) CC-L

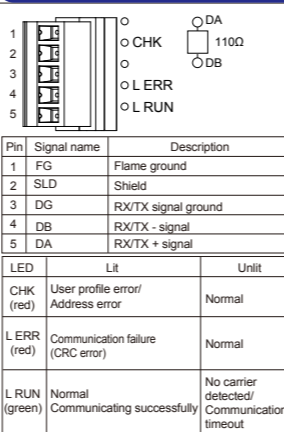

CC-L (Suffix code: Type 3=5)  
If the UT is located at the end of a segment for the CC-Link communication wiring, terminating resistors are separately needed. These are to be prepared by users. (110 Ω: 1 pc.)

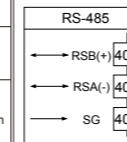

■ UP32A

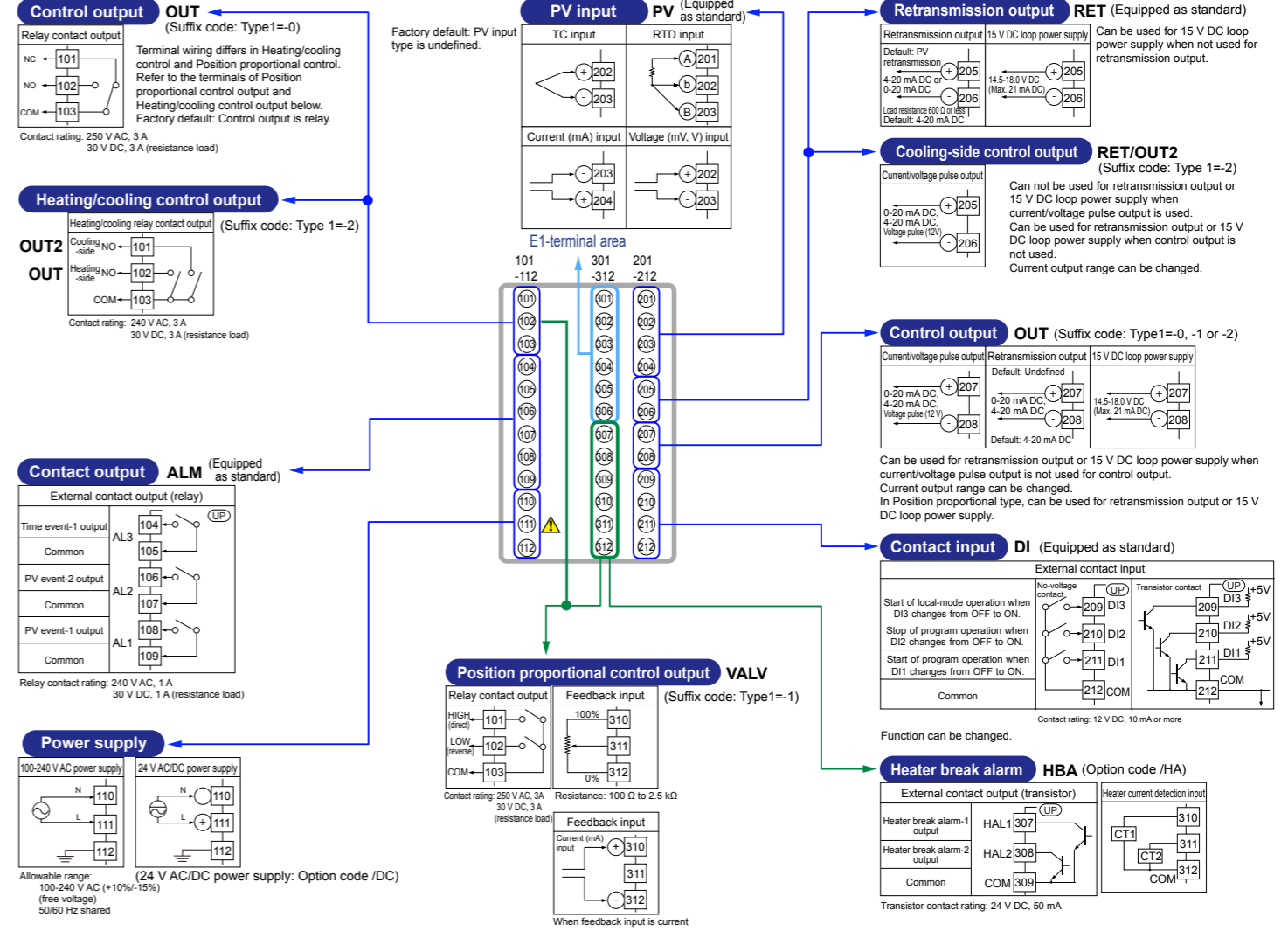

301-312 E1端子エリア

RS-485 communication RS485

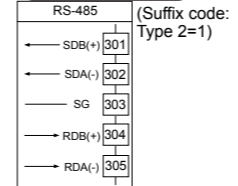

CC-Link communication (with Modbus master) CC-L

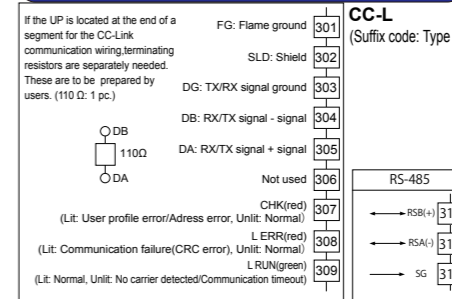

Contact input / Contact output DI/DO (Suffix code: Type 2=2)

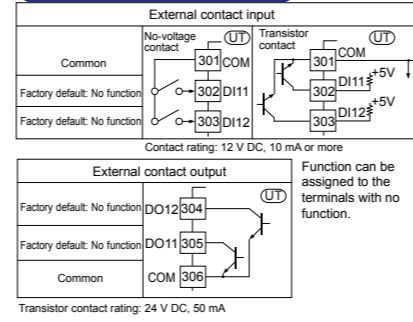

This operation guide describes basic settings and operations of the UP35A/UP32A. For details of each function, see the electronic manual. The scrolling guide is displayed on PV display in the Parameter Setting Display. This guide can be turned on/off with the MODE key. For details of the each function, refer to the electronic manual. Manuals can be downloaded or viewed at the following URL.

<http://www.yokogawa.com/ns/ut/im/>

## Contents

- Names and Functions of Display Parts
- Setup Procedure
- Quick Setting Function (Setting of Input and Output)
- Adjusting Valve Position Automatically (for a Position Proportional Type Controller Only)
- Setting Alarm Type
- Setting Alarm Setpoint

## 1. Names and Functions of Display Parts

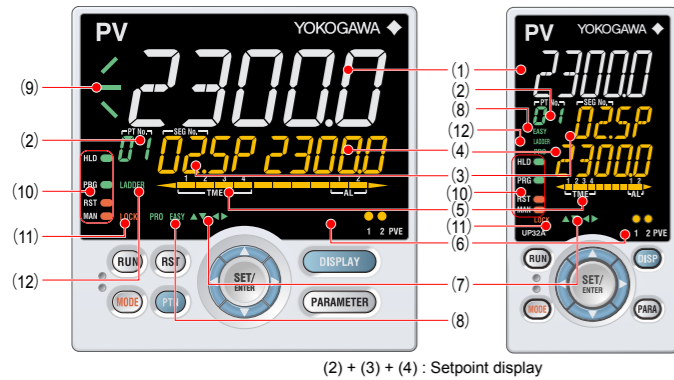

(2) + (3) + (4) : Setpoint display

No. in figure	Name	Description												
(1)	PV display (white or red)	Displays PV. Displays an error code if an error occurs. Displays the scrolling guide in the Menu Display and Parameter Setting Display when the guide display ON/OFF is set to ON.												
(2)	Group display (pattern number) (green)	1 to 4 represent pattern numbers in the Operation Display. Displays a group number (1 to 4 or R) and terminal area (E1 to E4) in the Parameter Setting Display.												
(3)	Symbol display (orange)	Displays a parameter symbol.												
(4)	Data display (orange)	Displays a parameter setpoint and menu symbol.												
(5)	Bar-graph display (event, alarm) (orange)	Displays the event status and the segment position in the Operation Display. (Default values: Time event status, Alarm status) Displays control output value (OUT) and measured input value (PV). The data to be displayed can be set by the parameter.												
(6)	Event indicator (orange)	Lit when the PV events occur. Event displays can be set by the parameter.												
(7)	Key navigation indicator (green)	Lit or blinks when the Up/Down or Left/Right arrow key operation is possible.												
(8)	Parameter display level indicator (green)	Displays the setting conditions of the parameter display level function. <table border="1"> <thead> <tr> <th>Parameter display level</th> <th>EASY</th> <th>PRO</th> </tr> </thead> <tbody> <tr> <td>Easy setting mode</td> <td>Lit</td> <td>Unlit</td> </tr> <tr> <td>Standard setting mode</td> <td>Unlit</td> <td>Unlit</td> </tr> <tr> <td>Professional setting mode</td> <td>Unlit</td> <td>Lit</td> </tr> </tbody> </table>	Parameter display level	EASY	PRO	Easy setting mode	Lit	Unlit	Standard setting mode	Unlit	Unlit	Professional setting mode	Unlit	Lit
Parameter display level	EASY	PRO												
Easy setting mode	Lit	Unlit												
Standard setting mode	Unlit	Unlit												
Professional setting mode	Unlit	Lit												
(9)	Program monitor (green) (UP35A only)	Displays the status of increment, constancy, and decrement of the program setpoint. <ul style="list-style-type: none"> <li>↖ : Lit when a program setpoint is increasing.</li> <li>↔ : Lit when a program setpoint is constant.</li> <li>↘ : Lit when a program setpoint is decreasing.</li> </ul>												
(10)	Status indicator (green and red)	Displays the operating conditions and control status. <table border="1"> <thead> <tr> <th>Indicator</th> <th>Description</th> </tr> </thead> <tbody> <tr> <td>HLD</td> <td>Lit when in hold mode (HLD).</td> </tr> <tr> <td>PRG</td> <td>Lit when in program pattern operation mode (PRG). Lit while the Starting time of program operation (S.TM) is available.</td> </tr> <tr> <td>RST</td> <td>Lit when in reset mode (RST). Blinks during auto-tuning.</td> </tr> <tr> <td>MAN</td> <td>Lit when in manual mode (MAN). Blinks during auto-tuning.</td> </tr> </tbody> </table>	Indicator	Description	HLD	Lit when in hold mode (HLD).	PRG	Lit when in program pattern operation mode (PRG). Lit while the Starting time of program operation (S.TM) is available.	RST	Lit when in reset mode (RST). Blinks during auto-tuning.	MAN	Lit when in manual mode (MAN). Blinks during auto-tuning.		
Indicator	Description													
HLD	Lit when in hold mode (HLD).													
PRG	Lit when in program pattern operation mode (PRG). Lit while the Starting time of program operation (S.TM) is available.													
RST	Lit when in reset mode (RST). Blinks during auto-tuning.													
MAN	Lit when in manual mode (MAN). Blinks during auto-tuning.													
(11)	Security indicator (red)	Lit if a password is set. The setup parameter settings are locked.												
(12)	Ladder operation indicator (green)	Lit while the ladder program operation is executed.												

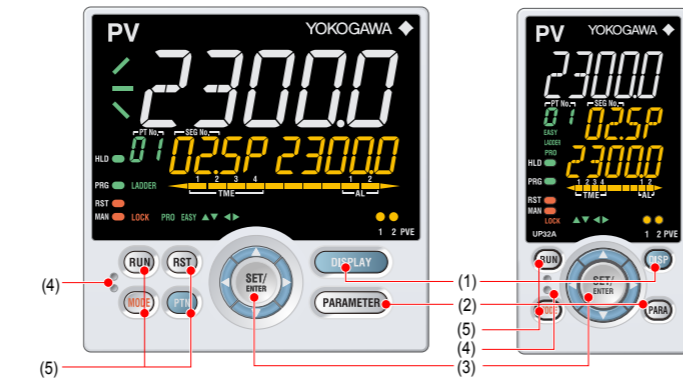

No. in figure	Name	Description
(1)	UP35A: DISPLAY key UP32A: DISP key	Used to switch the Operation Displays. Press the key in the Operation Display to switch the provided Operation Displays. Press the key in the Menu Display or Parameter Setting Display to return to the Operation Display.
(2)	UP35A: PARAMETER key UP32A: PARA key	Hold down the key for 3 seconds to move to the Operation Parameter Setting Display. Hold down the key and the Left arrow key simultaneously for 3 seconds to move to the Setup Parameter Setting Display. Press the key in the Parameter Setting Display to return to the Menu Display. Press the key once to cancel the parameter setting (setpoint is blinking).
(3)	SET/ENTER key Up/Down/Left/Right arrow keys	SET/ENTER key: Press the key in the Menu Display to move to the Parameter Setting Display of the Menu. Press the key in the Parameter Setting Display to transfer to the parameter setting mode (setpoint is blinking), and the parameter can be changed. Press the key during parameter setting mode to register the setpoint. Up/Down/Left/Right arrow keys: Press the Left/Right arrow keys in the Menu Display to switch the Displays. Press the Up/Down/Left/Right arrow keys in the Parameter Setting Display to switch the Displays. Press the Up/Down arrow keys during parameter setting mode (setpoint is blinking) to change a setpoint. Press the Left/Right arrow keys during parameter setting mode (setpoint is blinking) to move between digits according to the parameter.
(4)	Light-loader interface	It is the communication interface for the adapter cable used when setting and storing parameters from a PC. The LL50A Parameter Setting Software (sold separately) is required.
(5)	For UP35A, RUN key RST key MODE key PTN key For UP32A, RUN key MODE key	RUN key: Press the RUN key for 1 second while an operation display is shown starts the program pattern operation. RST key: Press the RST key for 1 second while an operation display is shown stops the program pattern operation. MODE key: Presents a display for switching between the HOLD, ADVANCE, PROG, RESET, LOCAL and AUTO/MAN. In order to change the operation mode, press the SET/ENTER key while the setpoint is blinking. PTN key: A program pattern number can be selected during the operation except the program pattern operation. (The program pattern number displayed on the Group display blinks.) When the PTN key is pressed while the program pattern number is blinking, the blink stops. Users can assign functions to the key using parameters.

Note: The communication connector (maintenance port) for LL50A Parameter Setting Software is on the top of the unit.

## 2. Setup Procedure

The following flowchart shows the setup procedure for UP35A/UP32A.

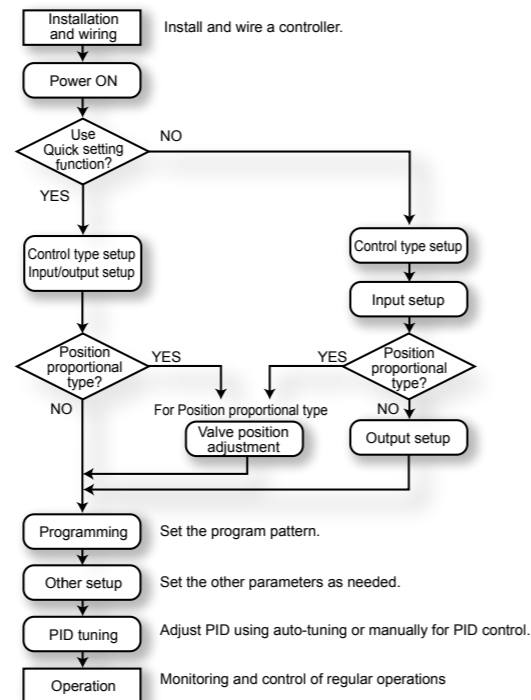

## 3. Quick Setting Function (Setting of Input and Output)

The Quick setting function is a function to easily set the basic function of the controller. Turn on the controller to start the Quick setting function. This function allows you to easily set the control type, input, and output, and quickly start the control action. The items (parameters) to be set by Quick setting function are as follows.  
(1) Control type (PID control, Heating/cooling control, etc.)  
(2) Input function (PV input type, range, scale (at voltage input), etc.)  
(3) Output function (control output type and cycle time)

After turning on the controller, first decide whether or not to use the Quick setting function.

### Operation in Initial Display

- Press the SET/ENTER key while YES is displayed to start the Quick setting function.
- If you change YES to NO and press the SET/ENTER key, Operation Display will appear without starting the Quick setting function.

### Flow of Quick Setting Function

In Quick setting mode, the parameter guide appears on PV display. This guide can be turned on/off with the MODE key.

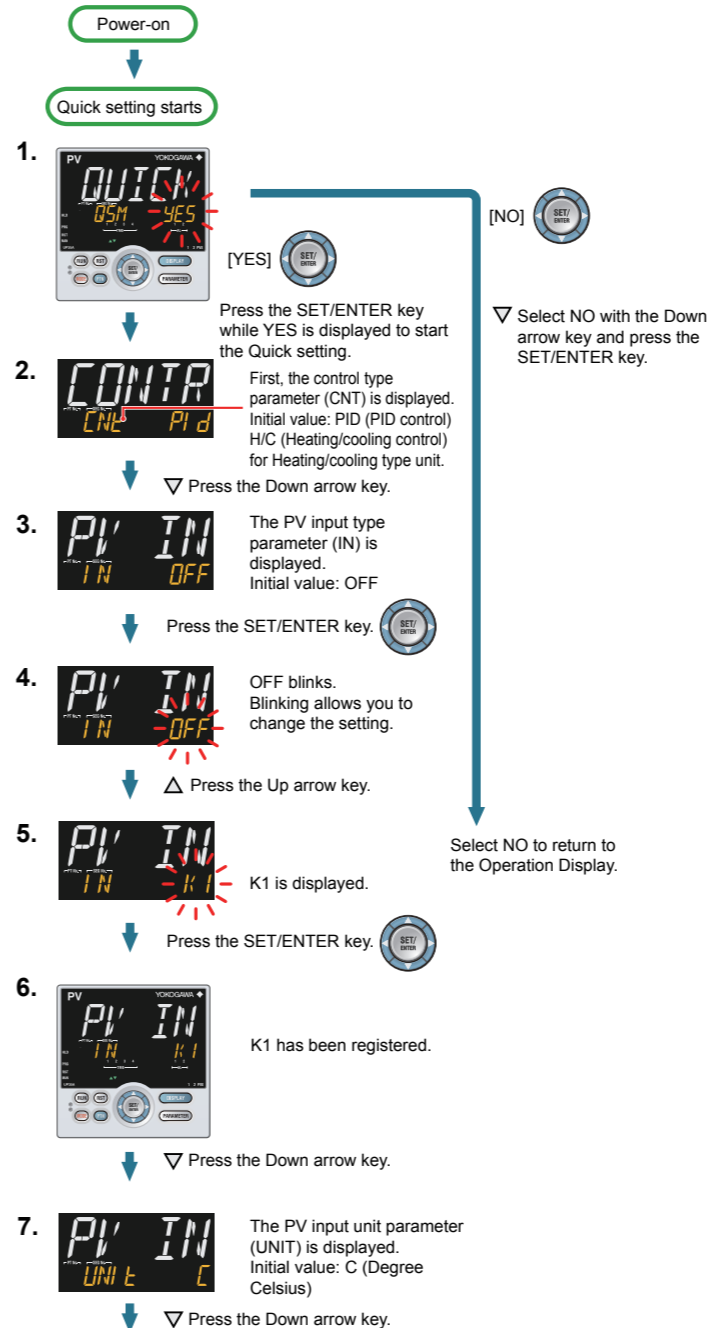

### Operation for Setting

- To select the parameter setting displayed as the initial value, press the Down arrow key to move to the next parameter.
- To change and set the parameter setting, press the SET/ENTER key to start the setpoint blinking. The blinking state allows you to make changes (setting mode). Use the Up/Down/Left/Right arrow keys to change the setpoint. Press the SET/ENTER key to register the setting.

### Making Settings Using Quick Setting Function

**Example: Setting to PID control, thermocouple type K (range of 0.0 to 500.0°C), and current control output**

For the detailed procedure and switching of displays, see "Flow of Quick Setting Function" below. For the parameters to set, see the next page.

- Press the SET/ENTER key while YES for QSM (Quick setting mode) is displayed.
- Set the control type parameter (CNT) to PID (PID control).
- Set the PV input type parameter (IN) to K1 (-270.0 to 1370.0 °C).
- Set the PV input unit parameter (UNIT) to C (Degree Celsius).
- Set the maximum value of PV input range parameter (RH) to 500.0.
- Set the minimum value of PV input range parameter (RL) to 0.0.
- Set the output type selection parameter (OT) to OUT terminals (current).
- Finally, EXIT is displayed. Change NO to YES and press the SET/ENTER key to complete the setup. Operation Display appears.

## Parameters to be set

### Control Type

Parameter Symbol	Name of Parameter	Setting Range
CNT	Control type	PID: PID control ONOF: ON/OFF control (1 point of hysteresis) ONOF2: ON/OFF control (2 points of hysteresis) H/C: Heating/cooling control

Note: Some setpoints may not be displayed depending on the model and suffix codes.

### Input Function

Parameter Symbol	Name of Parameter	Setting Range
IN	PV input type	OFF: Disable K1: -270.0 to 1370.0 °C / -450.0 to 2500.0 °F K2: -270.0 to 1000.0 °C / -450.0 to 2300.0 °F K3: -200.0 to 500.0 °C / -200.0 to 1000.0 °F J: -200.0 to 1200.0 °C / -300.0 to 2300.0 °F T1: -270.0 to 400.0 °C / -450.0 to 750.0 °F T2: 0.0 to 400.0 °C / -200.0 to 750.0 °F B: 0.0 to 1800.0 °C / 32 to 3300 °F S: 0.0 to 1700.0 °C / 32 to 3100 °F R: 0.0 to 1700.0 °C / 32 to 3100 °F N: -200.0 to 1300.0 °C / -300.0 to 2400.0 °F E: -270.0 to 1000.0 °C / -450.0 to 1800.0 °F L: -200.0 to 900.0 °C / -300.0 to 1600.0 °F U1: -200.0 to 400.0 °C / -300.0 to 750.0 °F U2: 0.0 to 400.0 °C / -200.0 to 1000.0 °F W: 0.0 to 2300.0 °C / 32 to 4200 °F PL2: 0.0 to 1390.0 °C / 32.0 to 2500.0 °F P2040: 0.0 to 1900.0 °C / 32 to 3400 °F WRE: 0.0 to 2000.0 °C / 32 to 3600 °F JPT1: -200.0 to 500.0 °C / -300.0 to 1000.0 °F JPT2: -150.00 to 150.00 °C / -200.0 to 300.0 °F PT1: -200.0 to 850.0 °C / -300.0 to 1560.0 °F PT2: -200.0 to 500.0 °C / -300.0 to 1000.0 °F PT3: -150.00 to 150.00 °C / -200.0 to 300.0 °F 0.4-2V: 0.400 to 2.000 V 1-5V: 1.000 to 5.000 V 4-20: 4.00 to 20.00 mA 0-2V: 0.000 to 2.000 V 0-10V: 0.00 to 10.00 V 0-20: 0.00 to 20.00 mA -1020: -10.00 to 20.00 mV 0-100: 0.0 to 100.0 mV
UNIT	PV input unit	-: No unit, C: Degree Celsius -: No unit, -: No unit, - -: No unit, F: Degree Fahrenheit
RH	Maximum value of PV input range	Depends on the input type. - For temperature input - Set the temperature range that is actually controlled. (RL<RH)
RL	Minimum value of PV input range	- For voltage / current input - Set the range of a voltage / current signal that is applied. The scale across which the voltage / current signal is actually controlled should be set using the maximum value of input scale (SH) and minimum value of input scale (SL). (Input is always 0% when RL = RH.)
SDP	PV input scale decimal point position	0: No decimal place 3: Three decimal places 1: One decimal place 4: Four decimal places 2: Two decimal places
SH	Maximum value of PV input scale	-19999 to 30000, (SL<SH),   SH - SL   ≤ 30000
SL	Minimum value of PV input scale	

Note 1: SDP, SH, and SL are displayed only for voltage/current input.

Note 2: W: W-5%Re/W-26%Re (Hoskins Mfg.Co.), ASTM E988

### Output Function

Parameter Symbol	Name of Parameter	Setting Range
OT	Output type selection	Control output or Heating-side control output (Lower two digits) 00: OFF 01: OUT terminals (voltage pulse) 02: OUT terminals (current) 03: OUT terminals (relay) 06: OUT2 terminals (relay) 07: RET/OUT2 terminals (voltage pulse) 08: RET/OUT2 terminals (current) Cooling-side control output (Upper two digits) 00: OFF 01: OUT terminals (voltage pulse) 02: OUT terminals (current) 03: OUT terminals (relay) 06: OUT2 terminals (relay) 07: RET/OUT2 terminals (voltage pulse) 08: RET/OUT2 terminals (current)
CT	Control output cycle time	0.5 to 1000.0 s
CTc	Cooling-side control output cycle time	

## 4. Adjusting Valve Position Automatically (for a Position Proportional Type Controller Only)

The following operating procedure describes how to input feedback signals from the control valve and adjust the fully-open and fully-closed positions of the control valve automatically. The fully-open and fully-closed positions of the valve can be adjusted automatically by inputting feedback signals from the valve. To adjust the valve position, you need to carry out the connection and bring the controller into manual mode. For the connection, see "6. Terminal Wiring Diagrams" in "Installation and Wiring", and for the manual mode, see "5. Switching between AUTO and MAN" in "Operations." The automatic adjustment can be done in program pattern operation and local operation.

1. Show the Operation Display.  
MAN is lit
2. Hold down the keys for 3 seconds. \* When a password is set, PASS is displayed. If the correct password is not entered, setup parameters cannot be changed. CTL menu is displayed.
3. Press the Right arrow key until OUT menu appears. OUT menu is displayed.
4. Press the SET/ENTER key. The parameter V.AT (automatic valve position adjustment) is displayed.
5. Press the SET/ENTER key. OFF blinks.
6. Press the Up arrow key. ON is displayed. Blinks during the change.
7. Press the SET/ENTER key. ON has been registered and the automatic adjustment of the valve position starts. V.AT blinks during the automatic adjustment. After the adjustment is completed, press the DISPLAY key or DISP key once to return to the Operation Display.

- When the adjustment is completed normally, the indication automatically returns to OFF.
- When VAT.E appears on PV display, it indicates an error. Check the wiring for feedback input and perform the automatic adjustment again. To perform a valve adjustment manually, see User's Manual.

## 5. Setting Alarm Type

The following operating procedure shows an example of changing the alarm-1 type (factory default: PV high limit alarm) to PV low limit alarm (setpoint: 02) (These alarms work irrespective of the operation mode.)

1. Show the Operation Display.
2. Hold down the key for 3 seconds. MODE menu is displayed.
3. Press the Right arrow key until ALRM menu appears. ALRM menu is displayed.
4. Press the SET/ENTER key. Press the Up/Down arrow keys to display the parameter needs to be changed. The parameter AL1 (alarm-1 type) is displayed.

5. The last digit of the setpoint blinks. Change the setpoint using the Up/Down arrow keys to increase and decrease the value and the Left/Right arrow keys to move between digits.
6. Press the SET/ENTER key. The alarm-1 type setpoint 02 (PV low limit) is registered. After the setup is completed, press the DISPLAY key once to return to the Operation Display.

- To change the alarm type, change the last 2 digits of the 5-digit value.
- Stand-by action and excitation are turned on or off by selecting 1 or 0. (See "Setting Display of Alarm Type.")
- For the latch action, see User's Manual.

Alarm Type (Alarm Setpoint)	Alarm Action (Energized)	Alarm Action (De-energized)
No alarm (00)	-	-
PV high limit (01) Analog input PV high limit (19)	Hysteresis Open (unit) Closed (lit) PV Alarm setpoint	Hysteresis Closed (lit) Open (unit) PV Alarm setpoint
PV low limit (02) Analog input PV low limit (20)	Hysteresis Closed (lit) Open (unit) Alarm setpoint PV	Hysteresis Open (lit) Closed (unit) Alarm setpoint PV
SP high limit (03) Target SP high limit (09)	Hysteresis Open (unit) Closed (lit) SP or Target SP	Hysteresis Closed (unit) Open (lit) SP or Target SP
SP low limit (04) Target SP low limit (10)	Hysteresis Closed (lit) Open (unit) Alarm setpoint SP or Target SP	Hysteresis Open (lit) Closed (unit) Alarm setpoint SP or Target SP
Deviation high limit (05) Target SP deviation high limit (11)	Hysteresis Open (unit) Closed (lit) PV Deviation setpoint SP or Target SP ⊕	Hysteresis Closed (unit) Open (lit) PV Deviation setpoint SP or Target SP ⊕
Deviation low limit (06) Target SP deviation low limit (12)	Hysteresis Closed (lit) Open (unit) Deviation setpoint PV SP or Target SP ⊖	Hysteresis Open (unit) Closed (lit) Deviation setpoint PV SP or Target SP ⊖
Deviation high and low limits (07) Target SP deviation high and low limits (13)	Hysteresis Hysteresis Closed (lit) Open (unit) Closed (lit) Deviation setpoint PV SP or Target SP	Hysteresis Hysteresis Open (lit) Closed (unit) Open (lit) Deviation setpoint PV SP or Target SP
Deviation within high and low limits (08) Target SP deviation within high and low limits (14)	Hysteresis Hysteresis Open (unit) Closed (lit) Open (unit) Deviation setpoint PV SP or Target SP	Hysteresis Hysteresis Closed (unit) Open (lit) Closed (unit) Deviation setpoint PV SP or Target SP
Control output high limit (15) Cooling-side control output high limit (17)	Hysteresis Open (unit) Closed (lit) Output Alarm setpoint	Hysteresis Closed (lit) Open (unit) Output Alarm setpoint
Control output low limit (16) Cooling-side control output low limit (18)	Hysteresis Closed (lit) Open (unit) Alarm setpoint Output	Hysteresis Open (lit) Closed (unit) Alarm setpoint Output
Feedback input high limit (27)	Fault diagnosis alarm (30) Burnout of PV input, ADC failure, RJC error.	
Feedback input low limit (28)	FAIL (31)	
PV velocity (29)	For the factory default, the contact output is turned ON in normal operation, OFF at the time of FAIL. Control output: OFF or 0%, Alarm output: OFF	

Note 1: "Open/closed" shows status of relay contact, and "lit/unlit" shows status of EV (event) lamp.

Note 2: ⊕ Positive setpoint, ⊖ Negative setpoint

### Setting Display of Alarm Type

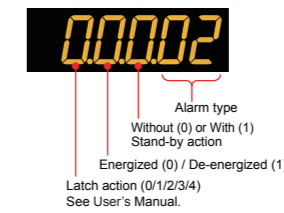

### Stand-by Action

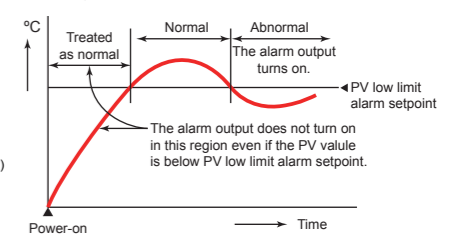

Note that the SP in reset-mode is SSP (Starting target setpoint).

## 6. Setting Alarm Setpoint

The following operating procedure shows an example of setting the alarm-1 setpoint to 180.0. (These alarms work irrespective of the operation mode.) Before setting the alarm setpoint, check the alarm type. To change the alarm type, see "5. Setting Alarm Type."

1. Show the Operation Display.
2. Display MODE menu with the same procedure as described in Setting Alarm Type.
3. Press the Right arrow key. AL menu is displayed.
4. Press the SET/ENTER key. The parameter A1 is displayed. A1 to A8 represent the alarm-1 to -8 setpoints.

Each parameter can be changed in the Parameter Setting Displays of alarms using arrow keys.  
△▽ Up/Down arrow keys: changing parameters

5. Display the parameter that need to be changed. Press the SET/ENTER key. Blinks during the change.
6. Change the setpoint using the Up/Down arrow keys to increase and decrease the value and the Left/Right arrow keys to move between digits. Press the SET/ENTER key. The setpoint has been registered. After the setup is completed, press the DISPLAY key once to return to the Operation Display.

## Initializing parameter values

Parameters that you have changed can be initialized to factory default values or user default values. For details, see "Parameter Initialization" in the User's Manual.

## Changing the parameter display levels

This operation guide does not explain all the parameters. To display all the parameters, you need to change the parameter display level to professional setting mode. For details, see "Setting Security Functions" in the User's Manual.

This operation guide describes basic program settings of the UP35A/UP32A. For details of each function, see the electronic manual. The scrolling guide is displayed on PV display in the Parameter Setting Display. This guide can be turned on/off with the MODE key. (The scrolling guide is OFF when displaying the Program parameter setting display first.) For details of the each function, refer to the electronic manual. Manuals can be downloaded or viewed at the following URL.

<http://www.yokogawa.com/ns/ut/im/>

**Contents**

1. Overview of Program Patterns
2. Creating Program Patterns
3. Program Pattern Setup Charts

**1. Overview of Program Patterns**

The programming example given here demonstrates how to do the tasks outlined below.

- 1) Program the controller to start program operation at 50.0°C and raise the temperature up to 100.0°C in 50 minutes.
- 2) When the temperature reaches 100.0°C, keep it at this level for 30 minutes.
- 3) Raise the temperature up to 200.0°C in 60 minutes.
- 4) When the temperature reaches 200.0°C, keep it at this level for 30 minutes.
- 5) Lower the temperature to 50.0°C in 50 minutes.
- 6) When the temperature reaches 50.0°C, keep it at this level for 30 minutes.

PV input ranges are following:  
 Maximum value of PV input range: 250.0°C  
 Minimum value of PV input range: 0.0°C  
 PV input unit: C

Zone PID selection (ZON): Segment PID selection (0)  
 Segment setting method (SEG.T): Segment time setting (TIME)  
 Program time unit (TMU): hour.minute (HH.MM)

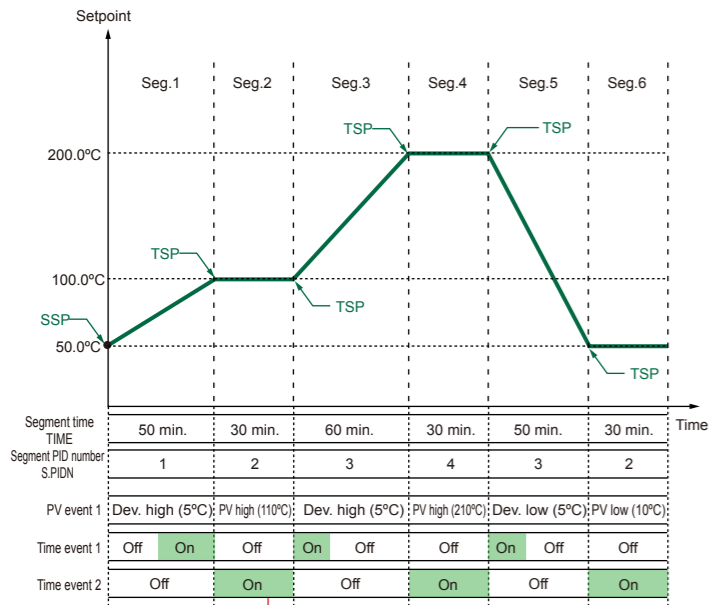

The display symbols of the parameters, TSP (Final target setpoint), TIME (Segment time setting), and S.PID (Segment PID number selection) are the same in each segment. However, the segment can be recognized by the number displayed on the Symbol display.

See User's Manual for the Wait and Repeat actions, Zone PID, Start of program operation (Start code), Changing operation mode at segment switching (Junction code), Local mode.

**2. Creating Program Patterns**

The following operating procedure describes an example of creating the program discussed in "1. Overview of Program Patterns."

**CAUTION** Before creating the program, reverify the PV Input Range, Program Time Unit (TMU), and Segment Setting Method (SEG.T) parameters. If the setting of these setup parameter is changed, the program patterns created and stored so far will be all cleared (initialized) !! Be careful.

1. Show the Operation Display.
2. Hold down the keys for 3 seconds. MODE menu is displayed.
3. Press the Right arrow key. PROG menu is displayed.
4. Press the SET/ENTER key. PTNO=1.
5. Press the SET/ENTER key. SEGNO=0.
6. Press the SET/ENTER key. Starting target setpoint=50.0°C.
7. Press the Down arrow key (until TSP appears).
8. Press the Down arrow key. STC=S5P (Starting target setpoint).
9. Press the SET/ENTER key. Segment 1.
10. Press the SET/ENTER key. Final target setpoint=100.0°C.
11. Press the Down arrow key.
12. Press the SET/ENTER key. Segment time=50 minutes.
13. Press the Down arrow key.
14. Press the Down arrow key.
15. Press the SET/ENTER key. PV event-1 type=Deviation high limit.
16. Press the SET/ENTER key. PV event-1 type=Deviation high limit.
17. Press the SET/ENTER key. PV event-1 setpoint=5.0°C.
18. Press the SET/ENTER key. PV event-1 setpoint=5.0°C.
19. Press the Down arrow key (until TIM1 appears).
20. Press the SET/ENTER key. On time=25 minutes.
21. Press the Down arrow key (until TIM2 appears).
22. Press the Down arrow key. There is no the Off time.
23. Press the Down arrow key (until TSP appears).
24. Press the Up/Down arrow keys to move the parameters for segment-1 and the Left/Right arrow keys to move between each segments.
25. Press the SET/ENTER key. Segment 2. Continues the TSP of segment 1.
26. Press the SET/ENTER key. Segment time=30 minutes.
27. Press the Down arrow key.
28. Press the SET/ENTER key. Segment PID number=2.
29. Press the Down arrow key.
30. Press the SET/ENTER key. PV event-1 type=PV high limit.
31. Press the SET/ENTER key. PV event-1 type=PV high limit.
32. Press the SET/ENTER key. PV event-1 setpoint=110.0°C.
33. Press the SET/ENTER key. PV event-1 setpoint=110.0°C.
34. Press the Down arrow key (until TIM2 appears).
35. Press the SET/ENTER key. Start condition of time event 2=ON start.
36. Press the SET/ENTER key. Start condition of time event 2=ON start.
37. Press the DISPLAY key once to return to the Operation Display.

• Settings for the segment 3 to 6 can be done similarly.  
 • For Programming and the settings for Wait and Repeat actions, see User's Manual.

### 3. Program Pattern Setup Charts

You can register max. 10 program segments/pattern with the UP35A controller. Create as many copies of the chart as necessary.

System name	
Program No.	
Program name	
Model	
Serial No.	

The following parameters are necessary to be set before programming. Note that the program is deleted if TMU or SEG.T is changed after creating programs. For the setting range, see "Parameters."

#### < Setup Parameters >

Parameter symbol	Parameter name	User settings
TMU	Program time unit	
SEG.T	Segment setting method	
ZON	Zone PID selection	

The following parameters are common parameters for the program pattern specified. For the setting range, see "Parameters."

#### < Program Pattern Data (common parameter) >

Parameter symbol	Parameter name	User settings
SSP	Starting target setpoint	
STC	Start code	
WT.SW1	Wait function ON/OFF	
WZ.UP1	Upper-side wait zone	
WZ.LO1	Lower-side wait zone	
WT.TM1	Wait time	
R.CYCL	Number of repeat cycles	
R.STRT	Repeat cycle start segment number	
R.END	Repeat cycle end segment number	

#### Error Indication at Program Pattern Creation and Editing

Error code	Error information	Cause of error
ERR01	Pattern creation or editing is disabled during program or local operation.	Deleting or copying of the program pattern, or inserting or deleting of the segment was executed during program operation.
ERR22	Segment write error	The total number of segments exceeded 20 (40 when the option "/AP" is specified.)
ERR23	Segment insert error	New segment cannot be inserted because the number of segments in a pattern exceeded 20 (40 when the option "/AP" is specified.)
ERR32	Pattern source specification error	No pattern exists in the source.
ERR33	Pattern destination specification error	Patterns already exist in the destination.
ERR41	Pattern delete error	The pattern to be deleted does not exist.

Except the above errors, there are some error codes in communication. For details, see User's Manual.

#### < Program Pattern Data (parameters for segments) >

Maximum value of PV input range / Maximum value of PV input scale ( )  
Unit ( )

A program pattern can be drawn in the right table.

Minimum value of PV input range / Minimum value of PV input scale ( )

Parameter symbol	Parameter name	Segments																				
		1	2	3	4	5	6	7	8	9	10	11	12	13	14	15	16	17	18	19	20	
TSP	Final target setpoint																					
TIME	Segment time setting																					
TM.RT	Segment ramp-rate setting																					
S.PID	Segment PID number selection																					
JC	Junction code																					
PV.TY1	PV event-1 type																					
PV.EV1	PV event-1 setpoint																					
PV.TY2	PV event-2 type																					
PV.EV2	PV event-2 setpoint																					
TME1	Start condition of time event 1																					
T.ON1	On time of time event 1																					
T.OF1	Off time of time event 1																					
TME2	Start condition of time event 2																					
T.ON2	On time of time event 2																					
T.OF2	Off time of time event 2																					
TME3	Start condition of time event 3																					
T.ON3	On time of time event 3																					
T.OF3	Off time of time event 3																					
TME4	Start condition of time event 4																					
T.ON4	On time of time event 4																					
T.OF4	Off time of time event 4																					



This operation guide describes key entries for operating the UP35A/UP32A. Although the display of UP35A is used in this guide, UP32A can be operated similarly. For operations using external contact inputs, see "DI" of "6. Terminal Wiring Diagrams" in "Installation and Wiring."

If you cannot remember how to carry out an operation during setting, press the DISPLAY key or DISP key once. This brings you to the display (Operation Display) that appears at power-on.

The scrolling guide is displayed on PV display in the Parameter Setting Display. This guide can be turned on/off with the MODE key.

For details of the each function, refer to the electronic manual. Manuals can be downloaded or viewed at the following URL.

<http://www.yokogawa.com/ns/ut/im/>

**Contents**

1. Monitoring-purpose Operation Displays Available during Operation
2. Performing/Canceling Auto-tuning
3. Selecting Program Pattern Number (PT.No)
4. Switching between RUN and RESET
5. Switching between AUTO and MAN
6. Manipulating Control Output in Manual Mode
7. Enabling/Disabling Hold-mode (HOLD) of Program Operation
8. Changing Program Setpoints when in Hold-mode (HOLD)
9. Executing "Advance" (ADV) Function
10. Switching to Local-mode (LOCAL) Operation
11. Changing Setpoints during Local-mode (LOCAL) Operation
12. Troubleshooting

**1. Monitoring-purpose Operation Displays Available during Operation**

**Operation Display Switching Diagram**

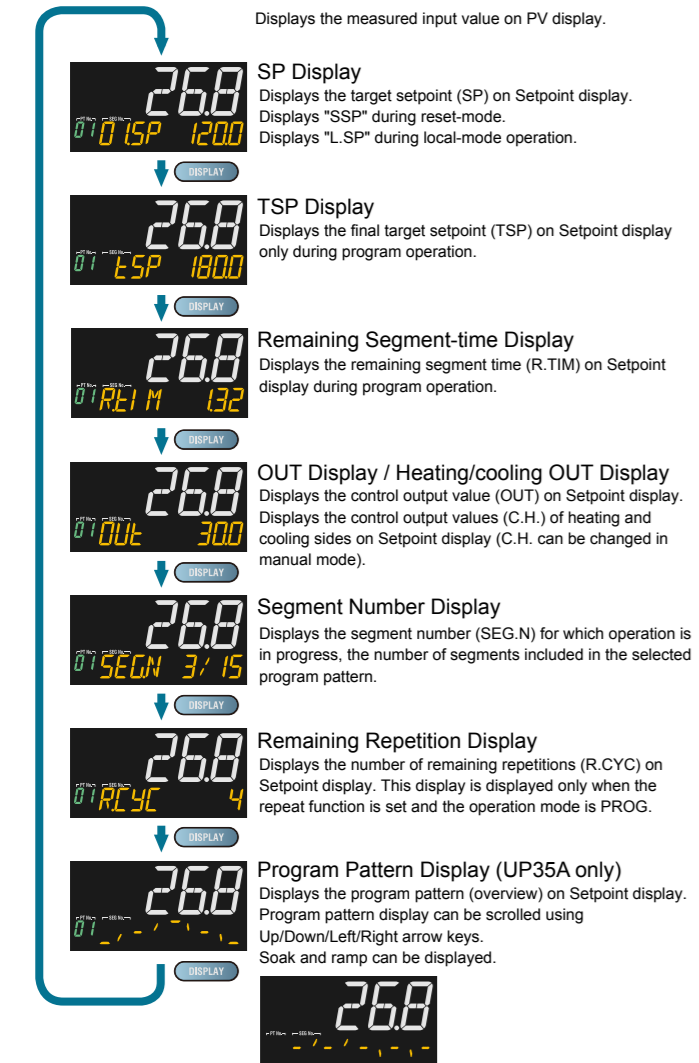

After showing the Program Pattern Display, press the DISPLAY key to show the following displays conditionally. For details, see User's Manual.

**Standard, Position Proportional, and Heating/Cooling Types**

- SELECT Displays 1 to 5 (which appear when registered)
- Analog Input Display (display only) (factory default: non-display)
- Position Proportional Computation Output Display (display only) (factory default: non-display)
- PID Number Display (display only) (factory default: non-display)
- Heater Break Alarm-1 Current Display (display only) (for heater break alarm option only)
- Heater Break Alarm-2 Current Display (display only) (for heater break alarm option only)

**Event Display**

Time event (TME), PV event (PVE) and alarm (AL) are displayed on the Bar-graph display and the Event Indicator. (factory default setting)

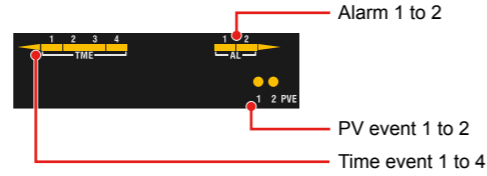

**Operation Display Switching Diagram**

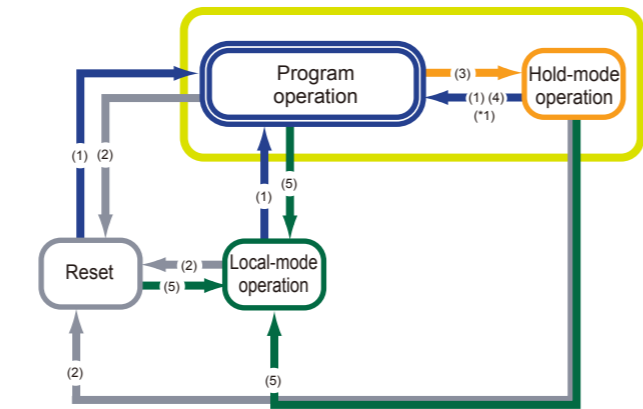

- (1) Press RUN key for 1 s.
  - UP35A: Press RST key for 1 s. UP32A: Press MODE key, select RST=ON and SET/ENT key.
  - Press MODE key, select HOLD=ON and press SET/ENT key.
  - Press MODE key, select HOLD=OFF and SET/ENT key.
  - Press MODE key, select LOC=ON and press SET/ENT key.
- \*1: For another operation, when select ADV=ON and starts program operation. In this case, the segment is advanced.

**2. Performing/Canceling Auto-tuning**

Auto-tuning should be performed after setting a program pattern. Make sure that the controller is in automatic mode (AUTO) and in run mode (RUN) before auto-tuning. For setting to AUTO, see "5. Switching between AUTO and MAN," and for setting to RUN, see "4. Switching between RUN and RESET."

If the setpoint is known in advance or auto-tuning does not find any appropriate PID constants, set the PID manually. For setting the PID manually, see User's Manual.



**Do not perform auto-tuning for the following processes.**

- Tune PID manually.**
- Processes with fast response such as flow rate control and pressure control.
  - Processes which do not allow the output to be turned on and off even temporarily.
  - Processes which prohibit severe output changes at control valves (or other actuators).
  - Processes in which product quality can be adversely affected if PV values fluctuate beyond their allowable ranges.

1. Show the Operation Display.
2. Hold down the PARAMETER key for 3 seconds to display MODE menu. Press the SET/ENTER key.
3. The parameter HOLD (Pause/cancel release of program operation.) is displayed (during program operation.) Press the Down arrow key until the parameter AT appears.

4. The parameter AT (auto-tuning switch) is displayed. Press the SET/ENTER key.
5. OFF blinks. Press the Up/Down arrow keys to display the required setpoint.
6. Blinks during the change. The setting range is 1 to 8 (represent group numbers) or R. To perform auto-tuning for the PID of group 1, set the parameter AT to 1. To quit the auto-tuning, set the parameter to OFF. Press the SET/ENTER key.
7. The setpoint has been registered. This starts auto-tuning. The limiter can be set to the output during auto-tuning. For details, see User's Manual.   
**During auto-tuning,**
  - The MAN lamp blinks.
  - The OUT symbol appears.
  - The output values at 100.0% and 0% appear alternately.
8. The MAN lamp goes off, which means that the auto-tuning completed normally.

**3. Selecting Program Pattern Number (PT.No)**

Program pattern number selection can be performed using any of the following: (1) key, (2) Parameter, (3) Contact input, and (4) Communication. The following shows an example of changing the program pattern (PTNO.) to 1 using the key. Program pattern number can be selected when the controller is in a RESET mode.

- UP35A
1. Show the Operation Display.
  2. RST lamp is lit. Press the PTN key.
  3. Press the Up/Down arrow keys to display the required setpoint. Blinks during the change. Press the SET/ENTER key.
  4. PTNO. has been changed to 1.

- UP32A
1. Show the Operation Display.
  2. RST lamp is lit. Press the MODE key.
  3. The PTNO. (Pattern number selection) is displayed.
  4. Press the Up/Down arrow keys to display the required setpoint. Blinks during the change. Press the SET/ENTER key.
  5. PTNO. has been changed to 1.

**4. Switching between RUN and RESET**

RUN and RESET switching can be performed using any of the following: (1) key, (2) Contact input, (3) Parameter, and (4) Communication. The following shows an example of switching using the key. For details of other switching methods and the display appearing when the operation is started, see User's Manual.

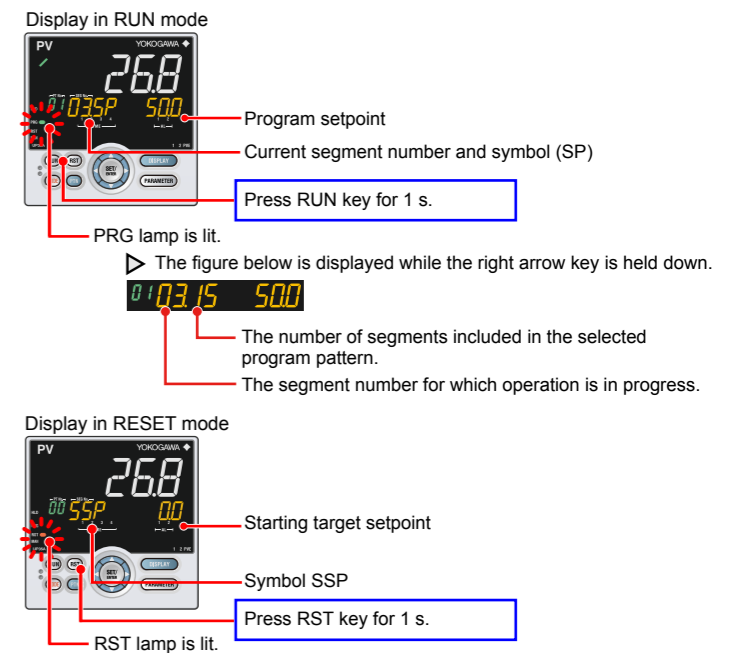

In the case of UP32A, Press MODE key, select RST=ON and SET/ENT key. (This procedure is similar to the operation of selecting the program pattern number.) however, the RST mode does not appear when the PRG/RESET switching function is assigned to contact input.

When the controller is stopped, input and outputs are as follows:

PV input	Displays the PV value.
Control output	When the zone PID selection parameter (ZON) is set to segment PID selection, the preset output value for the PID group number 1 is output. When the zone PID selection parameter (ZON) is set to other than segment PID selection, the preset output value for the PID group number for which zone control is performed is output.
Event output	Turns the output off in case of an event.
Alarm output	Turns the output on in case of an alarm.

## 5. Switching between AUTO and MAN

AUTO and MAN switching can be performed using any of the following: (1) MODE key, (2) Contact input, (3) Contact input, and (4) Communication. The following shows an example of switching using the MODE key. When AUTO and MAN switching function is assigned to the contact input, and the contact input is ON, the switching by key operation cannot be performed. For details, see User's Manual.

1. Show the Operation Display.
2. Press MODE key several times.
3. Displays "MODE MAN" in AUTO mode. Displays "MODE AUTO" in MAN mode. Press the SET/ENTER key.
4. Press the SET/ENTER key. MAN lamp is lit in MAN mode.

When AUTO is switched into MAN, the control output value in AUTO mode is held. The controller can be operated manually from the hold value. If the manual preset output is set (MPO parameter ≠ OFF), the controller can be operated manually from the arbitrary output value (MPO1 to MPO5 parameters).

## 6. Manipulating Control Output in Manual Mode

### NOTE

In manual mode, control output is manipulated by operating the keys (the value is changed using the Up/Down arrow keys, then outputted as it is). Even if the SET/ENTER key is not pressed, the control output value changes according to the displayed value.

In stop mode (when the RST lamp is lit), control output cannot be manipulated.

- Up arrow key: increases control output.  
Down arrow key: decreases control output.
- 
- MAN lamp is lit.

In Position proportional control:  
Up arrow key; opens the valve.  
Down arrow key; closes the valve.  
Output; only while pressing a key.  
OUT; valve opening (0-100%)

Output manipulation in Position proportional control is not restricted from output limiters (OH, OL).

### Manual operation in Heating/cooling control

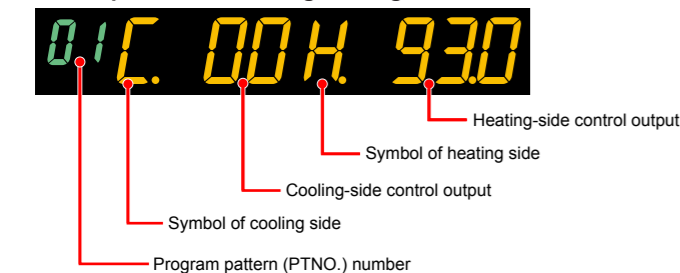

Up arrow key: concurrently decreases cooling-side control output and increases heating-side control output.  
Down arrow key: concurrently increases cooling-side control output and decreases heating-side control output.

(Either none of the heating-side and cooling-side outputs are presented, or both of them are presented according to the dead band setting.)

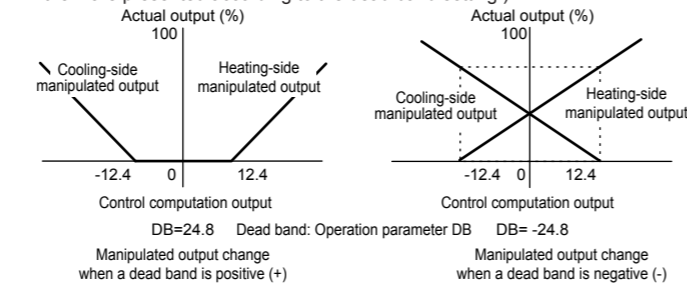

## 7. Enabling/Disabling Hold Mode of Program Operation

Enabling/disabling hold mode of program operation can be performed during program operation using any of the following: (1) MODE key, (2) Parameter, (3) Contact input, and (4) Communication. The following shows an example of switching using the MODE key.

1. Show the Operation Display.
2. Press the MODE key. The parameter HOLD (Pause/cancel release of program operation) is displayed (during program operation.)
3. Displays "HOLD ON" in PROG mode. Displays "HOLD OFF" in HOLD mode. Press the SET/ENTER key.
4. Press the SET/ENTER key. HLD lamp is lit in HOLD mode. The figure below is displayed while the right arrow key hold down. The number of segments included in the selected program pattern. The segment number for which operation is in progress.

Other operating procedures for disabling the hold mode:

- (1) Press the RUN key for 1 second during hold-mode operation. In this case, the controller resumes program operation.
- (2) Execute the "Advance" function during hold-mode operation. In this case, the segment is advanced.

## 8. Changing Program Setpoints when in Hold Mode

The following operating procedures changes a program setpoint of soak segment during Hold-mode operation. The program operation is started when releasing the Hold after changing the program setpoint.

1. Set program operation in hold mode. Press the SET/ENTER key.
2. Blinks during the change. Press the SET/ENTER key.
3. Blinks during the change. Press the Up/Down arrow keys to display the required setpoint. Press the SET/ENTER key.
4. Press the SET/ENTER key.

## 9. Executing "Advance" Function

"Advance" can be performed during program operation using any of the following: (1) MODE key, (2) Parameter, (3) Contact input, and (4) Communication. The following shows an example of switching using the MODE key.

When executing the "Advance" function during hold-mode operation, the hold mode is disabled.

1. Show the Operation Display.
2. Press the MODE key.
3. The ADV (Advance of segment) is displayed (during program operation.) Press the SET/ENTER key.
4. The segment is advanced. Press the SET/ENTER key.

## 10. Switching to Local-mode (LOCAL) Operation

Switching to local-mode can be performed using any of the following: (1) MODE key (user function key), (2) Parameter, (3) Contact input, and (4) Communication. The following shows an example of switching using the MODE key.

1. Show the Operation Display.
2. Press the MODE key several times.

3. The LOC (local operation) is displayed. Press the SET/ENTER key.
4. "LSP" is displayed when in local-mode operation. Press the SET/ENTER key.

## 11. Changing Setpoints during Local-mode Operation

The following operating procedures changes setpoints during local-mode operation.

1. "LSP" is displayed when in local-mode operation. Press the SET/ENTER key.
2. Blinks during the change. Press the Up/Down arrow keys to display the required setpoint.
3. Blinks during the change. Press the SET/ENTER key.
4. Press the SET/ENTER key.

## 12. Troubleshooting

### ■ Troubleshooting Flow

If the Operation Display does not appear after turning on the controller's power, check the procedures in the following flowchart. If a problem appears to be complicated, contact our sales representatives.

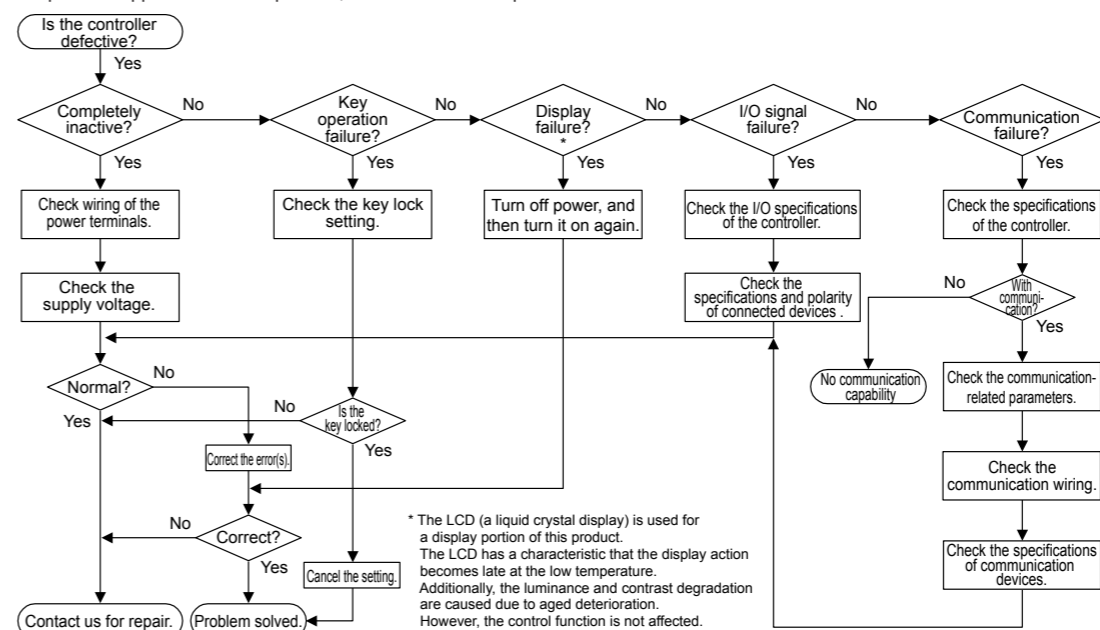

### ■ Remedies if Power Failure Occurs during Operations

- Instantaneous power failure within 20 ms. A power failure is not detected. Normal operation continues.
- Power failure for less than about 5 seconds, or for about 5 seconds or more. Affects the "settings" and "operation status." For details, see User's Manual.

### NOTE

Write down the settings of parameters for a repair request.

- For the Errors at Power On and the Errors during Operation, see "Parameters" in this manual.







### ■ AL1-AL3 Function Registration Parameter

Menu symbol: *ALM* (ALM)

Parameter symbol	Name of Parameter	Setting Range	Initial value	User setting	Display level
<i>AL1S</i> (AL1.S)	AL1 function selection	Set an I relay number. For the items other than below, see Communication User's Manual.	4801		STD
<i>AL2S</i> (AL2.S)	AL2 function selection	Ex.) Set the number 4353 for AL1.S to use the alarm 1.	4802		
<i>AL3S</i> (AL3.S)	AL3 function selection	Set "OFF" to disable the function. Setting range: 4001 to 6304 No function: OFF PV event 1: 4801, PV event 2: 4802 Time event 1: 4817, Time event 2: 4818, Time event 3: 4819, Time event 4: 4821 Alarm 1: 4353 Alarm 2: 4354 AUTO (OFF) / MAN (ON) status: 4177 Program RESET status: 4181 Program RUN status: 4182 Local operation status: 4183 HOLD mode status: 4189 Program advance status: 4187 Pattern end signal (1 second): 4266 Pattern end signal (3 seconds): 4267 Pattern end signal (5 seconds): 4268 Wait end signal (1 second): 4257 Wait end signal (3 seconds): 4258 Wait end signal (5 seconds): 4259 FAIL (Normally ON) output: 4256	4817		
<i>ORS</i> (OR.S)	OUT relay function selection		OFF		
<i>ORS2</i> (OR2.S)	OUT2 relay function selection		OFF		

### ■ DO Setting Parameter (E1-terminal Area)

Menu symbol: *DO* (DO)

Parameter symbol	Name of Parameter	Setting Range	Initial value	User setting	Display level
<i>DO1S</i> (DO1.S)	DO11 function selection	Same as AL1.S Set "OFF" to disable the function.	UP35A: 4353 UP32A: OFF	Table below	STD
<i>DO2S</i> (DO2.S)	DO12 function selection		UP35A: 4354 UP32A: OFF		
<i>DO3S</i> (DO3.S)	DO13 function selection		UP35A: 4818		
<i>DO4S</i> (DO4.S)	DO14 function selection		UP35A: 4819		
<i>DO5S</i> (DO5.S)	DO15 function selection		UP35A: 4821		

Use the following table to record DO setting value.

Parameter	E1-terminal Area
DO1.S	
DO2.S	
DO3.S	
DO4.S	
DO5.S	

### ■ System Setting Parameter

Menu symbol: *SYS* (SYS)

Parameter symbol	Name of Parameter	Setting Range	Initial value	User setting	Display level
<i>RMD</i> (R.MD)	Restart mode	Set how the controller should recover from a power failure of 5 seconds or more. CONT: Continue action set before power failure. MAN: Start from MAN. RESET: Start from AUTO and RESET. Outputs the preset output value.	CONT		STD
<i>RLM</i> (R.TM)	Restart timer	Set time between power on and the instant where controller starts computation. 0 to 10 s	0		
<i>EPO</i> (EPO)	Input error preset output	Set preset output value when the input burnout or ADC error occurs. Manual output is prioritized when the input burnout occurs in MAN. 0: Preset output 1: 0% output 2: 100% output	0		STD
<i>FREQ</i> (FREQ)	Power frequency	AUTO, 60: 60 Hz, 50: 50 Hz	AUTO		EASY
<i>QSM</i> (QSM)	Quick setting mode	OFF: Disable ON: Enable	ON		
<i>LANG</i> (LANG)	Guide display language	ENG: English FRA: French GER: German SPA: Spanish	Depends on the model and suffix codes		
<i>PASS</i> (PASS)	Password setting	0 (No password) to 65535	0		

### ■ Error and Version Confirmation Parameter (for display only)

Menu symbol: *VER* (VER)

Parameter symbol	Name of Parameter	Status record	Display level
<i>PRER</i> (PA.ER)	Parameter error status		EASY
<i>OPER</i> (OP.ER)	Option error status		
<i>AD1E</i> (AD1.E)	A/D converter error status 1		
<i>AD2E</i> (AD2.E)	A/D converter error status 2		
<i>PV1E</i> (PV1.E)	PV input error status		
<i>LAER</i> (LA.ER)	Ladder error status		
<i>MCU</i> (MCU)	MCU version		
<i>DCU</i> (DCU)	DCU version		
<i>ECU1</i> (ECU1)	ECU-1 version (E1-terminal area)		
<i>ECU3</i> (ECU3)	ECU-3 version (E3-terminal area)		
<i>ECU4</i> (ECU4)	ECU-4 version (E4-terminal area)		
<i>PARA</i> (PARA)	Parameter version		
<i>HVER</i> (H.VER)	Product version		
<i>SER1</i> (SER1)	Serial number 1		
<i>SER2</i> (SER2)	Serial number 2		
<i>MAC1</i> (MAC1)	MAC address 1 (E3-terminal area)		
<i>MAC2</i> (MAC2)	MAC address 2 (E3-terminal area)		
<i>MAC3</i> (MAC3)	MAC address 3 (E3-terminal area)		

### ■ Parameter Display Level Parameter

Menu symbol: *LVL* (LVL)

Parameter symbol	Name of Parameter	Setting Range	Initial value	User setting	Display level
<i>LEVL</i> (LEVL)	Parameter display level	EASY: Easy setting mode STD: Standard setting mode PRO: Professional setting mode	STD		EASY

\* For Professional setting mode, see User's Manual.

**Trademarks**

- Our product names or brand names mentioned in this manual are the trademarks or registered trademarks of Yokogawa Electric Corporation.
- Adobe, Acrobat, and Postscript are either registered trademarks or trademarks of Adobe Systems Incorporated.
- Ethernet is a registered trademark of XEROX Corporation in the United States.
- Modbus is a registered trademark of Schneider Electric.
- PROFIBUS-DP is a registered trademark of PROFIBUS User Organization.
- DeviceNet is a registered trademark of Open DeviceNet Vendor Association.
- CC-Link is a registered trademark of CC-Link Partner Association.
- We do not use the TM or ® mark to indicate these trademarks or registered trademarks in this manual.
- All other product names mentioned in this manual are trademarks or registered trademarks of their respective companies.

### [ Operations 13. Troubleshooting ] ■ Errors at Power On

The errors shown below may occur in the fault diagnosis when the power is turned on. (For details of Setpoint display and input/output action when each error occurs, see User's Manual.)

PV display (Operation Display)	Setpoint display (Operation Display)	Status indicator (Operation Display)	Parameter that displays error details	Error description	Cause and diagnosis	Remedy
Indication off	Indication off	—	—	Faulty MCU RAM / MCU ROM	MCU RAM / MCU ROM are failed.	Faulty. Contact us for repair.
ERR	SYS - - - -	—	—	System data error	System data is corrupted.	Faulty. Contact us for repair.
	PAR 0004 (for user default value error only)			User (parameter) default value error	User parameter is corrupted. Initialized to factory default value.	Check and reconfigure the initialized setting parameters. Error indication is erased when the power is turned on again.
	PAR 0010 (for setup parameter error only)			Setup parameter error	Setup parameter data is corrupted. Initialized to user default value.	
	PAR 0020 (for operation parameter error only)			Operation parameter error	Operation parameter data is corrupted. Initialized to user default value.	
	PAR 0040 (for program pattern error only)			Program pattern error	Program pattern data is corrupted. All program patterns are deleted.	
Normal indication	Normal indication	Rightmost decimal point on PV display blinks. Rightmost decimal point on Symbol display blinks.	Setup parameter (PA.ER)	Calibration value error	Initialized to calibrated default value because of corrupted factory default value.	Faulty. Contact us for repair.
				Faulty FRAM	Data writing (storing) to FRAM is impossible.	
Normal indication	Normal indication	LADDER lamp blinks	Setup parameter (LA.ER)	Corrupted ladder program	Ladder program is corrupted. Operates without ladder program.	Download the ladder program again.
Normal indication	0.000 00000 (Decimal point on the left of the Symbol display blinks)	—	Setup parameter (OP.ER)	User profile error	User profile is corrupted.	Download the user profile again.

### [ Operations 13. Troubleshooting ] ■ Errors during Operation

The errors shown below may occur during operation. (For input/output action when each error occurs, see User's Manual.)

PV display (Operation Display)	Setpoint display (Operation Display)	Status indicator (Operation Display)	Parameter that displays error details	Error description	Cause and diagnosis	Remedy
AD.ERR	Normal indication (Note)	—	Setup parameter (AD1.E)	Analog input terminal ADC error +PV input	Analog input terminal AD value error	Faulty. Contact us for repair.
RJC.E (Displays RJC, E and PV alternately.)	Normal indication (Note)	—	Setup parameter (AD1.E)	Universal input terminal RJC error +PV input	Universal input terminal RJC error	Faulty. Contact us for repair. Set the parameter RJC to OFF to erase error indication.
B.OUT	Normal indication (Note)	—	Setup parameter (AD1.E)	Analog input terminal burnout error +PV input	Analog input terminal sensor burnout	Check wiring and sensor. Error indication is erased in normal operation.
			Setup parameter (PV1.E)	PV input burnout error	Burnout of analog input connected to PV	Check wiring and sensor of connected analog input terminals. Error indication is erased in normal operation.
OVER- OVER	Normal indication	—	Setup parameter (PV1.E)	PV input over-scale PV input under-scale (PV values out of -5 to 105%)	PV input is out of -5 to 105%. Also occurs when the data out of range which is the ladder calculation result is input.	Check analog input value or ladder program.
Normal indication	OUT - - - -	—	Setup parameter (AD2.E)	Feedback input resistor/current burnout	Feedback input burnout	Check wiring of feedback input resistor/current. Error indication is erased in normal operation.
Normal indication	Normal indication	LADDER lamp blinks	Setup parameter (LA.ER)	Ladder calculation overflow	Floating point computation for ladder calculation is infinite.	Check the ladder program.
				Load factor over 100%	Computation does not end within the control period. (When the load factor is 100% or more, and the computation does not end within the control period.)	Change the control period or reduce the number of steps for the ladder program.
				Load factor over 200% (Forced end)	Computation does not end within the control period (load factor is 200% or more).	Change the control period or reduce the number of steps for the ladder program.
				Ladder program error	Ladder program is corrupted.	Download the ladder program again. If the error indication is still not erased, there is a fault. Contact us for repair.
Normal indication	0.000 00000 (Decimal point on the left of the Symbol display blinks)	—	Setup parameter (OP.ER)	Peer-to-peer communication error	Peer-to-peer communication error	Check that the target devices are connected correctly. Recovery at normal receipt.
				AT.E	Normal indication	—
VAT.E	Normal indication	—	Setup parameter (AD2.E)	Valve position automatic adjustment error	Fully-closed valve position is equal to or larger than the fully-open valve position after automatic valve position adjustment is performed.	Check wiring and valve. Hold down any key to erase the error indication.
Normal indication	0.000 00000 (Decimal point on the left of the Symbol display blinks)	—	Setup parameter (OP.ER)	Communication error (RS-485 communication)	Framing parity error Buffer overflow Inter-character time-out Checksum error (PC link communication with checksum) CRC check error (Modbus/RTU) LRC check error (Modbus/ASCII)	Check the communication parameters. Recovery at normal receipt. Hold down any key to stop blinking.
Normal indication	0.000 00000 (Decimal point on the left of the Symbol display blinks)	—	Setup parameter (OP.ER)	User profile error	User profile is corrupted.	Download the user profile again.
Normal indication	Normal indication	Rightmost decimal point on Symbol display blinks.	Setup parameter (PA.ER)	Faulty FRAM	Writing (storing) data to FRAM is impossible.	Faulty. Contact us for repair.
Undefined	Undefined	—	—	Faulty MCU / DCU (ROM / RAM error, corrupted)	MCU / DCU is corrupted.	Faulty. Contact us for repair.

Note: When an error occurs in input shown in Analog input display (Operation display), Setpoint display shows the same symbol as the PV display.