

PROPLUS Batch Controllers

YPP6210 Analog Input & YPP6310 Pulse Input



PROPLUS



- YPP6210: 0-20 mA, 4-20 mA, 0-5 V, 1-5 V, ± 10 V Inputs
- YPP6310: Pulse, Open Collector, NPN, PNP, TTL, Switch Contact, Sine Wave (Coil), Square Wave Inputs
- NEMA 4X, IP65 Front
- Start/Pause/Stop, Change Batch with Front Panel Buttons
- Single or Multi-Stage Batch Control (Up to 8 Relays)
- Automatic Overrun Correction
- Rate in Units per Second, Minute, Hour, or Day
- Automatic or Manual Batch Control
- Low or High Flow Alarms
- 9 Digit Grand Total with Overflow Feature
- Count Up or Down with Each Batch
- Configure, Monitor, and Datalog from a PC with Free PROPLUS Software

YOKOGAWA ◆

2 Dart Road • Newnan, Georgia 30265

770-253-7000 • 800-888-6400

Fax: 770-251-2088 • www.yokogawa-usa.com

Disclaimer

The information contained in this document is subject to change without notice. Yokogawa Corporation of America makes no representations or warranties with respect to the contents hereof; and specifically disclaims any implied warranties of merchantability or fitness for a particular purpose.



CAUTION: *Read complete instructions prior to installation and operation of the controller.*



WARNING: *Risk of electric shock or personal injury.*



Warning

This product is not recommended for life support applications or applications where malfunctioning could result in personal injury or property loss. Anyone using this product for such applications does so at his/her own risk. Yokogawa Corporation of America shall not be held liable for damages resulting from such improper use.

Limited Warranty

Yokogawa Corporation of America warrants this product against defects in material or workmanship for the specified period under “Specifications” from the date of shipment from the factory.

Yokogawa’s liability under this limited warranty shall not exceed the purchase value, repair, or replacement of the defective unit.

Registered Trademarks

All trademarks mentioned in this document are the property of their respective owners.

© 2012 Yokogawa Corporation of America. All rights reserved.

www.yokogawa-usa.com

Table of Contents

INTRODUCTION	7
ORDERING INFORMATION	7
SPECIFICATIONS	9
General	9
YPP6210 Process Input	11
YPP6310 Pulse Input	11
Batch Controller Rate/Totalizer Display	13
Relays	14
Isolated 4-20 mA Transmitter Output	15
Modbus [®] RTU Serial Communications	15
YPPA1044 Digital Input & Output Expansion Module	16
COMPLIANCE INFORMATION	16
Safety	16
Electromagnetic Compatibility	16
SAFETY INFORMATION	17
INSTALLATION	18
Unpacking	18
Panel Mounting Instructions	18
Mounting Dimensions	19
Configuration for 12 or 24 VDC Power Option	20
Transmitter Supply Voltage Selection (P+, P-)	21
Connections	21
Connectors Labeling	22
Power Connections	23
YPP6210 Signal Connections	23
YPP6310 Signal Connections	25
Modbus RTU Serial Communications	27
Relay Connections	27
Switching Inductive Loads	28
F4 Digital Input Connections	29
4-20 mA Output Connections	29
Analog Output Transmitter Power Supply	29
External Relay & Digital I/O Connections	30
Interlock Relay Feature	31
BASIC OPERATION AND PROGRAMMING	32
Front Panel Buttons and Status LED Indicators	33
Controller Operation	34
Batch Control Operation Example	35

Display Functions and Messages -----	38
Setting Numeric Values -----	43
Setting Up the Batch Controller (SEtUP) -----	43
Scaling and Calibration-----	45
Setting the Input Signal (<i>inPUL</i>)-----	45
Setting the Totalizer and Batching Features (<i>totRL</i>)-----	45
Setting the Input Units or Custom Tags (<i>un itS</i>)-----	46
Setting the Decimal Point (<i>dEc Pt</i>)-----	47
Programming the Batch Controller (<i>PracU</i>)-----	47
Input Calibration Method (<i>inLRl</i>)-----	48
YPP6310 Only: K-Factor Calibration (<i>FRct or</i>)-----	48
Scaling the Controller (<i>SLRLE</i>)-----	49
Time Base, Total Conversion Factor & Total Reset-----	50
Batch Start Mode (<i>nr adE</i>)-----	50
Calibrating the Controller with External Source (<i>LRl</i>)-----	51
Setting the Display Parameter & Intensity (<i>dSPLRy</i>)-----	52
Display Setup Menu-----	53
Setting the Relay Operation (rELRY) -----	54
Relay Assignment (<i>R55 in</i>)-----	55
Setting the Relay Action-----	56
Setting Batch Control Relays-----	56
Programming Alarm Set and Reset Points-----	57
Setting Fail-Safe Operation-----	57
Programming Time Delay-----	57
Relay Action for Loss of 4-20 mA Input (Loop Break)-----	57
Relay Operation Details -----	58
Overview-----	58
Relays Initialization-----	58
Fail-Safe Operation-----	58
Front Panel LEDs-----	59
Automatic Reset (<i>RUL a</i>)-----	59
Pump Alternation Control-----	59
Setting Up the Interlock Relay (Force On) Feature-----	60
Sample Relay Operation-----	61
Relay and Alarm Operation Diagrams -----	61
High Alarm Operation (Set > Reset)-----	61
Low Alarm Operation (Set < Reset)-----	61
High Alarm with Fail-Safe Operation (Set > Reset)-----	62
Low Alarm with Fail-Safe Operation (Set < Reset)-----	62
Rate Relay Sampling Operation-----	63
Total Relay Sampling Operation-----	63
Signal Loss or Loop Break Relay Operation-----	64
Time Delay Operation-----	65

Scaling the 4-20 mA Analog Output (Rout)	66
Reset Menu (rESEt)	67
Control Menu (ContRL)	67
Setting Up the Password (PR55)	68
Protecting or Locking the Controller	68
Grand Total Reset Password & Non-Resettable Total	69
Making Changes to a Password Protected Controller	69
Disabling Password Protection	69
ADVANCED OPERATION AND PROGRAMMING	70
Advanced Features Menu & Display Messages	71
F4 Operation	74
Multi-Point Calibration & Scaling	74
PROPLUS Software	75
Noise Filter Bypass (bYP55)	76
Rounding Feature (round)	76
Modbus RTU Serial Communications (5Er RL)	76
Select Menu (SELEt)	77
Signal Conditioning Selection (Functn)	78
Low-Flow Cutoff (LwtoFF)	78
Total and Grand Total Count Direction (Count)	79
Analog Output Programming (RoutPr)	79
Programmable Function Keys User Menu (u5Er)	80
YPP6210 Only: Internal Source Calibration (iRL)	81
Controller Copy Function (CoPY)	83
TROUBLESHOOTING	84
Diagnostics Menu (d RL)	84
Determining Software Version	84
Reset Controller to Factory Defaults	85
Factory Defaults & User Settings	86
Troubleshooting Tips	90
Alphabetical List of Display Functions & Messages	91

Table of Figures

Figure 1: 1/8 DIN Panel Mounting	18
Figure 2: Controller Dimensions - Side View	19
Figure 3: Controller Dimensions - Top View	19
Figure 4: Jumper Configuration for 12/24 VDC Power	20
Figure 5: Transmitter Supply Voltage Selection	21
Figure 6: Connector Labeling for Fully Loaded YPP6210.....	22
Figure 7: Connector Labeling for Fully Loaded YPP6310.....	22
Figure 8: Power Connections.....	23
Figure 9: Transmitters Powered by Internal Supply	23
Figure 10: Transmitter Powered by Ext. Supply or Self-Powered ...	24
Figure 11: Voltage Input Connections	24
Figure 12: Flowmeter Powered by Internal Power Supply	25
Figure 13: Flowmeter Powered by External Supply	25
Figure 14: Self-Powered Magnetic Pickup Coil Flowmeter.....	25
Figure 15: NPN open Collector Input.....	26
Figure 16: PNP Sensor Powered by Internal Supply	26
Figure 17: Switch Input Connections	26
Figure 18: Relay Connections	27
Figure 19: AC and DC Loads Protection	28
Figure 20: Low Voltage DC Loads Protection.....	28
Figure 21: F4 Digital Input Connections	29
Figure 22: 4-20 mA Output Connections	29
Figure 23: Expansion Modules & DIN Rail Mounting Kit.....	30
Figure 24: External Relays Module Connections	30
Figure 25: Digital I/O Module Connections	31
Figure 26: Interlock Connection.....	31

INTRODUCTION

The PROPLUS YPP6210 and YPP6310 are easy to use batch controllers ideal for simplifying independent batch control operations where local control is preferred to expensive and expansive plant operation systems.

The controller comes programmed for easy front panel start, pause, stop, and batch size (preset) changes. The bottom display can be programmed to display rate, grand total, batch count, or preset by cycling the Stop (F3) button. A digital input is standard.

Single and multi-stage batching is possible with up to 4 on-board relays and 4 with the external relay module. Each batch control relay may have a unique preclose amount when used for multi-stage batching.

Manual start batching is default, but automatic batching with a restart after a programmed time delay from the completion of the last batch, is also possible.

Overrun correction adjusts the closing of the batch control relays to adjust for inaccuracies from batch to batch. This increases accuracy over time as systems wear out. The overrun correction feature is capable of compensating for inaccuracies of up to 10% of the programmed preset value.

At least two SPDT relays are included for use in batch control or rate alarms.

The batch controllers also share all common PROPLUS Series features, including an isolated 24 VDC transmitter power supply and Modbus RTU Serial communications.

ORDERING INFORMATION

Analog Input Standard Models

85-265 VAC Model	12/24 VDC Model	Options Installed
YPP6210-6R2	YPP6210-7R2	2 relays
YPP6210-6R4	YPP6210-7R4	4 relays
YPP6210-6R5	YPP6210-7R5	2 relays & 4-20 mA output
YPP6210-6R7	YPP6210-7R7	4 relays & 4-20 mA output

Analog Input SunBright Display Models

85-265 VAC Model	12/24 VDC Model	Options Installed
YPP6210-6H2	YPP6210-7H2	2 relays
YPP6210-6H4	YPP6210-7H4	4 relays
YPP6210-6H5	YPP6210-7H5	2 relays & 4-20 mA output
YPP6210-6H7	YPP6210-7H7	4 relays & 4-20 mA output

Pulse Input Standard Models

85-265 VAC Model	12/24 VDC Model	Options Installed
YPP6310-6R2	YPP6310-7R2	2 relays
YPP6310-6R4	YPP6310-7R4	4 relays
YPP6310-6R5	YPP6310-7R5	2 relays & 4-20 mA output
YPP6310-6R7	YPP6310-7R7	4 relays & 4-20 mA output

Pulse Input SunBright Display Models

85-265 VAC Model	12/24 VDC Model	Options Installed
YPP6310-6H2	YPP6310-7H2	2 relays
YPP6310-6H4	YPP6310-7H4	4 relays
YPP6310-6H5	YPP6310-7H5	2 relays & 4-20 mA output
YPP6310-6H7	YPP6310-7H7	4 relays & 4-20 mA output

Accessories

Model	Description
YPPA1002	DIN rail mounting kit for two expansion modules
YPPA1004	4 SPST (Form A) relays
YPPA1044	4 digital inputs & 4 digital outputs (2 may be connected)
YPPA1200	Meter copy cable
YPPA1232	RS-232 serial adapter
YPPA1485	RS-485 serial adapter
YPPA7485-I	RS-232 to RS-422/485 isolated converter
YPPA8232-N	USB to RS-232 non-isolated converter
YPPA8485-I	USB to RS-422/485 isolated converter
YPPA8008	USB serial adapter
YPPX6901	Suppressor (snubber): 0.01 μ F/470 Ω , 250 VAC

Enclosures

Model	Description
YPPA2811	1 Meter Plastic NEMA 4X Enclosure
YPPA2812	2 Meter Plastic NEMA 4X Enclosure

SPECIFICATIONS

Except where noted all specifications apply to operation at +25°C.

General

DISPLAY	Upper display: 0.6" (15 mm) high, red LEDs Lower display: 0.46" (12 mm) high, red LEDs 6 digits: each (-99999 to 999999), with lead zero blanking.
DEFAULT DISPLAY ASSIGNMENT	The Upper display shows batch total. The Lower display shows rate with alternating units, and can be switched to show grand total, batch count, or preset with the STOP key.
CUSTOM DISPLAY ASSIGNMENT	The Upper and Lower displays may be assigned to rate, total, grand total, batch count, preset, set points, units (lower display only), alternating R & T, R & GT, preset & rate, max & min, or a Modbus display register. Any rate/total/grand total display may be programmed to alternate with a custom unit or tag.
ALTERNATING DISPLAY	Displays alternate every 10 seconds when display is selected or the batch is paused.
DISPLAY INTENSITY	Eight user selectable intensity levels
DISPLAY UPDATE RATE	5/second (200 ms)
OVERRANGE	Display flashes 999999
UNDERRANGE	Display flashes -999999
FRONT PANEL	NEMA 4X, IP65
PROGRAMMING METHODS	Four front panel buttons, digital inputs, PC and PROPLUS software, or cloning using Copy function.
NOISE FILTER	Programmable from 2 to 199 (0 will disable filter) (YPP6210 only)
FILTER BYPASS	Programmable from 0.1 to 99.9% of calibrated span (YPP6210 only)
RECALIBRATION	All ranges are calibrated at the factory. Recalibration is recommended at least every 12 months.
MAX/MIN DISPLAY	Max/min readings reached by the process are stored until reset by the user or until power to the controller is cycled.

Model YPP6210 & YPP6310 Batch Controllers Instruction Manual

PASSWORD	Three programmable passwords restrict modification of programmed settings and two prevent resetting the totals. Pass 1: Allows use of function keys and digital inputs Pass 2: Allows use of function keys, digital inputs and editing set/reset points Pass 3: Restricts all programming, function keys, and digital inputs. Total Password: Prevents resetting the total manually Gtotal Password: Prevents resetting the grand total manually
NON-VOLATILE MEMORY	All programmed settings are stored in non-volatile memory for a minimum of ten years if power is lost.
POWER OPTIONS	85-265 VAC 50/60 Hz, 90-265 VDC, 20 W max or jumper selectable 12/24 VDC \pm 10%, 15 W max
FUSE	Required external fuse: UL Recognized, 5 A max, slow blow; up to 6 controllers may share one 5 A fuse
ISOLATED TRANSMITTER POWER SUPPLY	Terminals P+ & P-: 24 VDC \pm 10%. 12/24 VDC powered models selectable for 24, 10, or 5VDC supply (internal jumper J4). 85-265 VAC models rated @ 200 mA max, 12/24 VDC powered models rated @ 100 mA max, @ 50 mA max for 5 or 10 VDC supply.
NORMAL MODE REJECTION	Greater than 60 dB at 50/60 Hz
ISOLATION	4 kV input/output-to-power line 500 V input-to-output or output-to-P+ supply
OVERVOLTAGE CATEGORY	Installation Overvoltage Category II: Local level with smaller transient overvoltages than Installation Overvoltage Category III.
ENVIRONMENTAL	Operating temperature range: -40 to 65°C Storage temperature range: -40 to 85°C Relative humidity: 0 to 90% non-condensing
CONNECTIONS	Removable screw terminal blocks accept 12 to 22 AWG wire, RJ45 for external relays, digital I/O, and serial communication adapters.
ENCLOSURE	1/8 DIN, high impact plastic, UL 94V-0, color: black
MOUNTING	1/8 DIN panel cutout required: 3.622" x 1.772" (92 mm x 45 mm) Two panel mounting bracket assemblies are provided.
TIGHTENING TORQUE	Screw terminal connectors: 5 lb-in (0.56 Nm)
OVERALL DIMENSIONS	4.68" x 2.45" x 5.64" (119 mm x 62 mm x 143 mm) (W x H x D)
WEIGHT	9.5 oz (269 g)
WARRANTY	3 years parts & labor

YPP6210 Process Input

INPUTS	Field selectable: 0-20, 4-20 mA, ± 10 V (0-5, 1-5, 0-10 V), Modbus PV (Slave)								
ACCURACY	$\pm 0.03\%$ of calibrated span ± 1 count, square root & programmable exponent accuracy range: 10-100% of calibrated span								
TEMPERATURE DRIFT	0.005% of calibrated span/ $^{\circ}$ C max from 0 to 65 $^{\circ}$ C ambient, 0.01% of calibrated span/ $^{\circ}$ C max from -40 to 0 $^{\circ}$ C ambient								
SIGNAL INPUT CONDITIONING	Linear, square root, or programmable exponent								
MULTI-POINT LINEARIZATION	2 to 32 points								
PROGRAMMABLE EXPONENT	1.0001 to 2.9999								
LOW-FLOW CUTOFF	0-999999 (0 disables cutoff function)								
DECIMAL POINT	Up to five decimal places or none: <i>d.ddddd, d.dddd, d.ddd, d.dd, d.d, or d</i>								
CALIBRATION RANGE	<table border="0"> <tr> <td>Input</td> <td>Minimum Span</td> </tr> <tr> <td>Range</td> <td>Input 1 & Input 2</td> </tr> <tr> <td>4-20 mA</td> <td>0.15 mA</td> </tr> <tr> <td>± 10 V</td> <td>0.10 V</td> </tr> </table> <p>An error message will appear if the input 1 and input 2 signals are too close together.</p>	Input	Minimum Span	Range	Input 1 & Input 2	4-20 mA	0.15 mA	± 10 V	0.10 V
Input	Minimum Span								
Range	Input 1 & Input 2								
4-20 mA	0.15 mA								
± 10 V	0.10 V								
INPUT IMPEDANCE	Voltage ranges: greater than 500 k Ω Current ranges: 50 - 100 Ω (depending on resettable fuse impedance)								
INPUT OVERLOAD	Current input protected by resettable fuse, 30 VDC max. Fuse resets automatically after fault is removed.								
F4 DIGITAL INPUT CONTACTS	3.3 VDC on contact. Connect normally open contacts across F4 to COM.								
F4 DIGITAL INPUT LOGIC LEVELS	Logic High: 3 to 5 VDC Logic Low: 0 to 1.25 VDC								

YPP6310 Pulse Input

INPUTS	Field selectable: Pulse or square wave 0-5 V, 0-12 V, or 0-24 V @ 30 kHz; TTL; open collector 4.7 k Ω pull-up to 5 V @ 30 kHz; NPN or PNP transistor, switch contact 4.7 k Ω pull-up to 5 V @ 40 Hz; Modbus PV (Slave)
LOW VOLTAGE MAG PICKUP (Isolated)	Sensitivity: 40 mVp-p to 8Vp-p
MINIMUM INPUT	0.001 Hz

Model YPP6210 & YPP6310 Batch Controllers Instruction Manual

FREQUENCY	Minimum frequency is dependent on high gate setting.
MAXIMUM INPUT FREQUENCY	30,000 Hz (10,000 for low voltage mag pickup)
INPUT IMPEDANCE	Pulse input: Greater than 300 k Ω @ 1 kHz. Open collector/switch input: 4.7 k Ω pull-up to 5 V.
ACCURACY	$\pm 0.03\%$ of calibrated span ± 1 count
TEMPERATURE DRIFT	Rate display is not affected by changes in temperature.
MULTI-POINT LINEARIZATION	2 to 32 points
LOW-FLOW CUTOFF	0-999999 (0 disables cutoff function)
DECIMAL POINT	Up to five decimal places or none: <i>d.dddddd, d.ddddd, d.ddddd, d.dd, dd, or ddddddd</i>
CALIBRATION	May be calibrated using K-factor, internal calibration, or by applying an external calibration signal.
K-FACTOR	Field programmable K-factor converts input pulses to rate in engineering units. May be programmed from 0.00001 to 999,999 pulses/unit.
CALIBRATION RANGE	Input 1 signal may be set anywhere in the range of the controller; input 2 signal may be set anywhere above or below input 1 setting. Minimum input span between any two inputs is 10 Hz. An error message will appear if the input 1 and input 2 signals are too close together.
FILTER	Programmable contact de-bounce filter: 40 to 999 Hz maximum input frequency allowed with low speed filter.
TIME BASE	Second, minute, hour, or day
GATE	Low gate: 0.1-99.9 seconds High gate: 2.0-999.9 seconds
F4 DIGITAL INPUT CONTACTS	3.3 VDC on contact. Connect normally open contacts across F4 to COM.
F4 DIGITAL INPUT LOGIC LEVELS	Logic High: 3 to 5 VDC Logic Low: 0 to 1.25 VDC

Batch Controller Rate/Totalizer Display

RATE DISPLAY INDICATION	-99999 to 999999, lead zero blanking. "R" LED illuminates while displaying rate.
BATCH TOTAL & GRAND TOTAL DISPLAY	0 to 999,999; automatic lead zero blanking. "T" LED is illuminated while displaying batch total. "GT" LEDs are illuminated while displaying grand total. Up to 999,999 for batch total/preset. Up to 999,999,999 with grand total-overflow feature. "OF" is displayed to the left of grand total overflow and ▲ LED is illuminated.
BATCH TOTAL DECIMAL POINT	Up to five decimal places or none: <i>d.dddddd, d.ddddd, d.dddd, d.ddd, dd, or ddddddd</i> Total decimal point is independent of rate decimal point.
TOTALIZER	Calculates total based on rate and field programmable multiplier to display total in engineering units. Time base must be selected according to the time units in which the rate is displayed.
GRAND TOTALIZER ROLLOVER	Grand totalizer rolls over when display exceeds 999,999,999. Relay status reflects display.
GRAND TOTAL ALARMS	Up to seven, user selectable under setup menu. Any set point can be assigned to grand total and may be programmed anywhere in the range of the controller for grand total alarm indication. Relay 1 should always be assigned to batch.
PROGRAMMABLE DELAY ON RELEASE	0.1 and 999.9 seconds; applied to the first relay assigned to total or grand total. If the controller is programmed to reset total to zero automatically when the preset is reached, then a delay will occur before the total is reset.
GRAND TOTAL RESET	Via front panel button, external contact closure on digital inputs, automatically via user selectable preset value and time delay, or through serial communications.
GRAND TOTAL RESET PASSWORD	Grand total passwords may be entered to prevent resetting the grand total from the front panel.
NON-RESETTABLE GRAND TOTAL	The grand total can be programmed as a non-resettable total by entering the password "050873".  <i>Once the Grand Total has been programmed as "non-resettable" the feature cannot be disabled.</i> Caution!

Relays

RATING	2 or 4 SPDT (Form C) internal and/or 4 SPST (Form A) external; rated 3 A @ 30 VDC and 125/250 VAC resistive load; 1/14 HP (\approx 50 W) @ 125/250 VAC for inductive loads
NOISE SUPPRESSION	Noise suppression is recommended for each relay contact switching inductive loads; see page 28 for details.
RELAY ASSIGNMENT	Relays may be assigned to batch control total, sampling, rate, or grand total alarms.
PRECLOSE	0-100% of batch size, individually user programmable for each additional batch control relay beyond the first.
ALARM DEADBAND	0-100% of span, user programmable
HIGH OR LOW ALARM	User may program any alarm for high or low trip point. Unused alarm LEDs and relays may be disabled (turn off).
RELAY OPERATION	Batch control Automatic (non-latching) ¹ Sampling Off (disable unused relays and enable Interlock feature) Manual on/off control mode Secondary Functions ² Pump alternation control (2 to 8 relays) Latching (requires manual acknowledge)
RELAY RESET	User selectable via front panel buttons, digital inputs, or PC <ol style="list-style-type: none"> 1. Automatic reset only (non-latching), when the input passes the reset point or total is reset to zero. 2. Automatic + manual reset at any time (non-latching) 3. Manual reset only, at any time (latching) 4. Manual reset only after alarm condition has cleared (L) <p><i>Note: Digital inputs may be assigned to acknowledge relays programmed for manual reset. It is not recommended to change the functions of front panel buttons to manual reset.</i></p>
ALARM TIME DELAY	0 to 999.9 seconds, on & off relay time delays Programmable and independent for each relay.
FAIL-SAFE OPERATION	Programmable and independent for each relay. <i>Note: Relay coil is energized in non-alarm condition. In case of power failure, relay will go to alarm state.</i>
ALARM AUTO INITIALIZATION	When power is applied to the controller, relays will reflect the state of the input to the controller. ¹

1. Alarms are active only when the batch is running.
2. These functions are not functional when the unit is being used as a batch controller with total set to yes.

Isolated 4-20 mA Transmitter Output

OUTPUT SOURCE	Rate/process, total, grand total, max, min, set points 1-8, Modbus register, or manual control mode		
SCALING RANGE	1.000 to 23.000 mA for any display range.		
CALIBRATION	Factory calibrated: 4.000 to 20.000 = 4-20 mA output		
ANALOG OUT PROGRAMMING	23.000 mA maximum for all parameters: Ovrrange, underrange, max, min, and break		
ACCURACY	± 0.1% FS ± 0.004 mA		
TEMPERATURE DRIFT	0.4 $\mu\text{A}/^\circ\text{C}$ max from 0 to 65°C ambient, 0.8 $\mu\text{A}/^\circ\text{C}$ max from -40 to 0°C ambient <i>Note: Analog output drift is separate from input drift.</i>		
ISOLATED TRANSMITTER POWER SUPPLY	Terminals I+ & R: 24 VDC ± 10% . May be used to power the 4-20 mA output or other devices.Refer to Figure 6 on page 22 and Figure 22 on page 29.		
EXTERNAL LOOP POWER SUPPLY	35 VDC maximum		
OUTPUT LOOP RESISTANCE	Power supply	Minimum	Maximum
	24 VDC	10 Ω	700 Ω
	35 VDC (external)	100 Ω	1200 Ω

Modbus[®] RTU Serial Communications

SLAVE ID	1 – 247 (Controller address)		
BAUD RATE	300 - 19,200 bps		
TRANSMIT TIME DELAY	Programmable between 0 and 199 ms		
DATA	8 bit (1 start bit, 1 or 2 stop bits)		
PARITY	Even, Odd, or None with 1 or 2 stop bits		
BYTE-TO-BYTE TIMEOUT	0.01 – 2.54 second		
TURN AROUND DELAY	Less than 2 ms (fixed)		

Note: Refer to the PROPLUS Modbus Register Tables located at www.yokogawa-usa.com for details.

YPPA1044 Digital Input & Output Expansion Module

CHANNELS	4 digital inputs & 4 digital outputs per module
SYSTEM	Up to 2 modules for a total of 8 inputs & 8 outputs
DIGITAL INPUT LOGIC HIGH	3 to 5 VDC
DIGITAL INPUT LOGIC LOW	0 to 1.25 VDC
DIGITAL OUTPUT LOGIC HIGH	3.1 to 3.3 VDC
DIGITAL OUTPUT LOGIC LOW	0 to 0.4 VDC
SOURCE CURRENT	10 mA maximum output current
SINK CURRENT	1.5 mA minimum input current
+5 V TERMINAL	To be used as pull-up for digital inputs only Connect normally open pushbuttons across +5 V & DI 1-4.

COMPLIANCE INFORMATION**Safety**

UL & c-UL LISTED	USA & Canada UL 508 Industrial Control Equipment
UL FILE NUMBER	E348677
FRONT PANEL	UL Type 4X, NEMA 4X, IP65; panel gasket provided
LOW VOLTAGE DIRECTIVE	EN 61010-1:2001 Safety requirements for measurement, control, and laboratory use

Electromagnetic Compatibility

EMISSIONS	EN 55022:2006/A1:2007 Class A ITE emissions requirements
Radiated Emissions	Class A
AC Mains Conducted Emissions	Class A
IMMUNITY	EN 61326-1:2006 Measurement, control, and laboratory equipment EN 61000-6-2:2005 EMC heavy industrial generic immunity standard

Model YPP6210 & YPP6310 Batch Controllers Instruction Manual

RFI - Amplitude Modulated	80 -1000 MHz 10 V/m 80% AM (1 kHz) 1.4 - 2.0 GHz 3 V/m 80% AM (1 kHz) 2.0 - 2.7 GHz 1 V/m 80% AM (1 kHz)
Electrical Fast Transients	±2kV AC mains, ±1kV other
Electrostatic Discharge	±4kV contact, ±8kV air
RFI - Conducted	10V, 0.15-80 MHz, 1kHz 80% AM
AC Surge	±2kV Common, ±1kV Differential
Surge	1KV (CM)
Power-Frequency Magnetic Field	3 A/m 70%V for 0.5 period
Voltage Dips	40%V for 5 & 50 periods 70%V for 25 periods
Voltage Interruptions	<5%V for 250 periods

Note:

Testing was conducted on YPP6200 and YPP6300 series meters installed through the covers of grounded metal enclosures with cable shields grounded at the point of entry representing installations designed to optimize EMC performance. All hardware is identical to the YPP6210 and YPP6310 controllers.

Declaration of Conformity available at www.yokogawa-usa.com

SAFETY INFORMATION



CAUTION: Read complete instructions prior to installation and operation of the controller.



WARNING: Risk of electric shock or personal injury.



Warning!

Hazardous voltages exist within enclosure. Installation and service should be performed only by trained service personnel.

INSTALLATION

There is no need to remove the controller from its case to complete the installation, wiring, and setup of the controller for most applications. Instructions are provided for setting up a 12/24 VDC powered controller to operate from 12 VDC and for changing the transmitter power supply to output 5 or 10 VDC instead of 24 VDC, see page 20.

Unpacking

Remove the controller from box. Inspect the packaging and contents for damage. Report damages, if any, to the carrier. If any part is missing or the controller malfunctions, please contact your supplier or the factory for assistance.

Panel Mounting Instructions

- Prepare a standard 1/8 DIN panel cutout – 3.622" x 1.772" (92 mm x 45 mm). Refer to Figure 1 for more details.
- Clearance: allow at least 6.0" (152 mm) behind the panel for wiring.
- Panel thickness: 0.04" - 0.25" (1.0 mm - 6.4 mm).
Recommended minimum panel thickness to maintain Type 4X rating: 0.06" (1.5 mm) steel panel, 0.16" (4.1 mm) plastic panel.
- Remove the two mounting brackets provided with the controller (back-off the two screws so that there is ¼" (6.4 mm) or less through the bracket. Slide the bracket toward the front of the case and remove).
- Insert controller into the panel cutout.
- Install mounting brackets and tighten the screws against the panel. To achieve a proper seal, tighten the mounting bracket screws evenly until controller is snug to the panel along its short side. **DO NOT OVER TIGHTEN**, as the rear of the panel may be damaged.

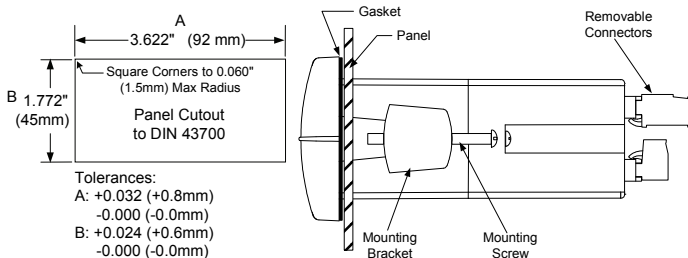

Figure 1: 1/8 DIN Panel Mounting

Mounting Dimensions

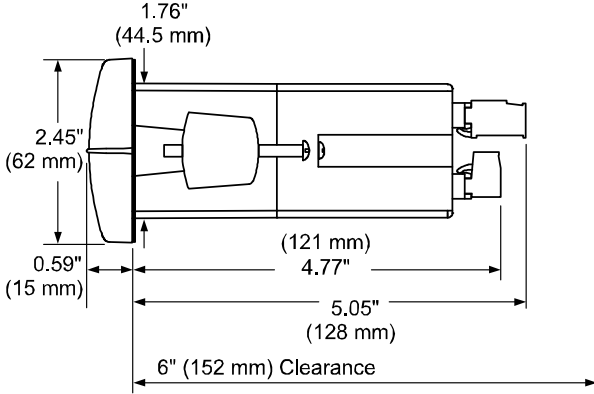

Figure 2: Controller Dimensions - Side View

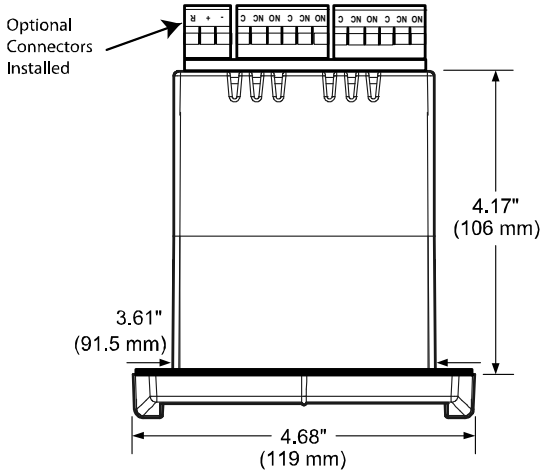

Figure 3: Controller Dimensions - Top View



Warning!

Do not exceed voltage rating of the selected configuration.

Controllers equipped with the 12/24 VDC power option are shipped from the factory ready to operate from 24 VDC.

To configure the controller for 12 VDC power:

1. Remove all the connectors.
2. Unscrew the back cover.
3. Slide the back cover about 1 inch.
4. Configure the J9 jumper, located behind the power connector, for 12 V as shown below.

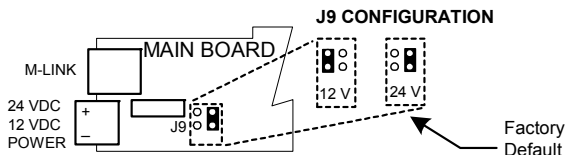

Figure 4: Jumper Configuration for 12/24 VDC Power

Transmitter Supply Voltage Selection (P+, P-)

All controllers, including models equipped with the 12/24 VDC power option, are shipped from the factory configured to provide 24 VDC power for the transmitter or sensor.

If the transmitter requires 5 or 10 VDC excitation, the internal jumper J4 must be configured accordingly.

To access the voltage selection jumper:

1. Remove all the connectors.
2. Unscrew the back cover.
3. Slide the back cover about 1 inch.
4. Configure the J4 jumper, located behind the input signal connector, for the desired excitation voltage as shown.

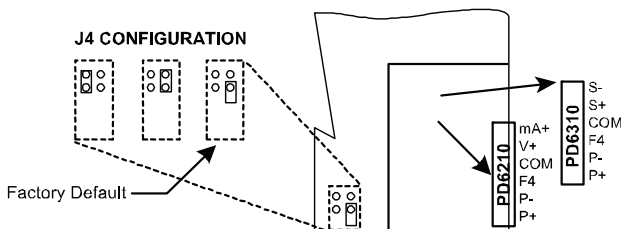

Figure 5: Transmitter Supply Voltage Selection
6000SensorExcitation

Connections

All connections are made to removable screw terminal connectors located at the rear of the controller.



Caution!

Use copper wire with 60°C or 60/75°C insulation for all line voltage connections. Observe all safety regulations. Electrical wiring should be performed in accordance with all applicable national, state, and local codes to prevent damage to the controller and ensure personnel safety.

Connectors Labeling

The connectors' label, affixed to the controller, shows the location of all connectors available with requested configuration.



Warning!

Do not connect any equipment other than Yokogawa's expansion modules, cables, or controllers to the RJ45 M-LINK connector. Otherwise damage will occur to the equipment and the controller.

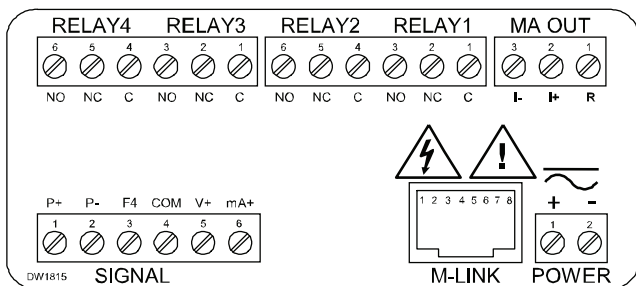

Figure 6: Connector Labeling for Fully Loaded YPP6210

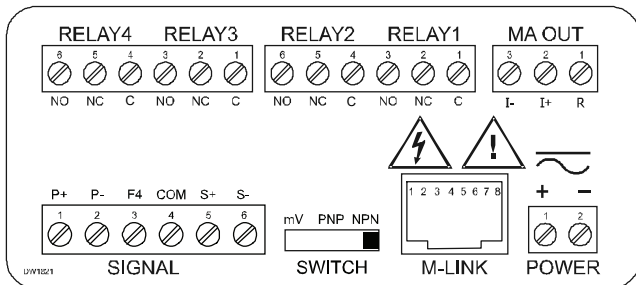
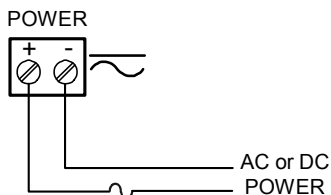

Figure 7: Connector Labeling for Fully Loaded YPP6310

Power Connections

Power connections are made to a two-terminal connector labeled POWER on Figure 6. The controller will operate regardless of DC polarity connection. The + and - symbols are only a suggested wiring convention.



Required External Fuse:
5 A max, 250 V Slow Blow

Figure 8: Power Connections

YPP6210 Signal Connections

Signal connections are made to a six-terminal connector labeled SIGNAL on Figure 6. The COM (common) terminal is the return for the 4-20 mA and the ± 10 V input signals.

Current and Voltage Connections

The following figures show examples of current and voltage connections. There are no switches or jumpers to set up for current and voltage inputs. Setup and programming is performed through the front panel buttons.

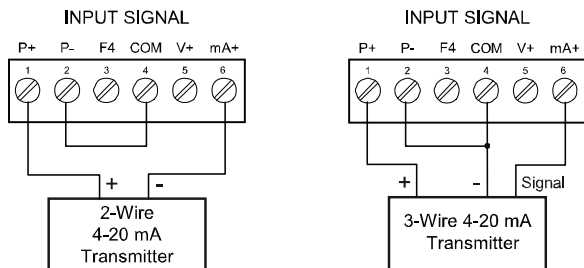

Figure 9: Transmitters Powered by Internal Supply

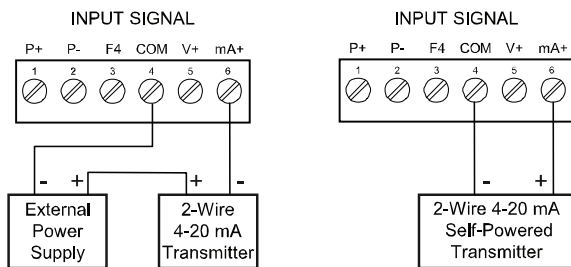

Figure 10: Transmitter Powered by Ext. Supply or Self-Powered

The current input is protected against current overload by a resettable fuse. The display may or may not show a fault condition depending on the nature of the overload.

The fuse limits the current to a safe level when it detects a fault condition, and automatically resets itself when the fault condition is removed.

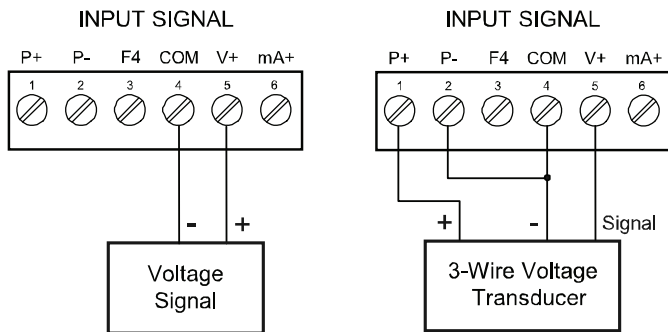

Figure 11: Voltage Input Connections

The controller is capable of accepting any voltage from -10 VDC to +10 VDC.

YPP6310 Signal Connections

Signal connections are made to a six-terminal connector labeled SIGNAL on Figure 7. The COM (common) terminal is the return for the input signals.

The following figures show examples of signal connections.

Setup and programming is performed through the front panel buttons.

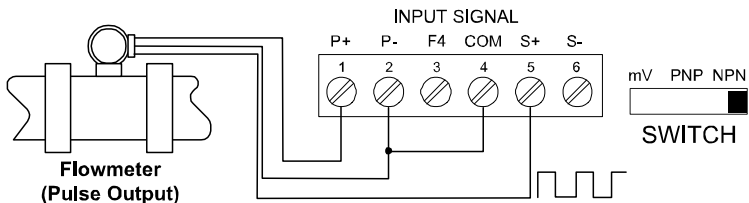

Figure 12: Flowmeter Powered by Internal Power Supply

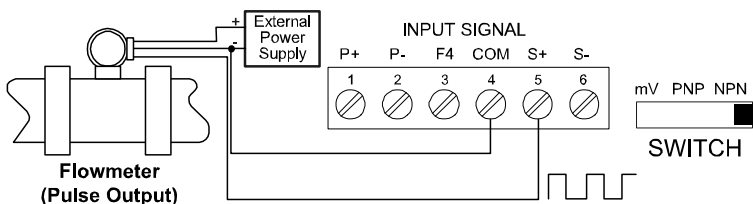

Figure 13: Flowmeter Powered by External Supply

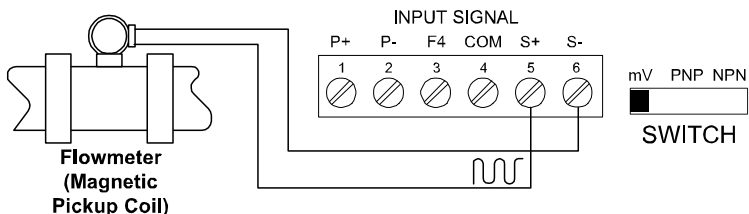

Figure 14: Self-Powered Magnetic Pickup Coil Flowmeter

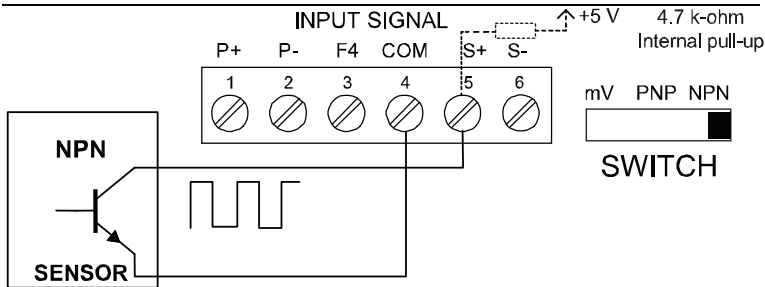

Figure 15: NPN open Collector Input

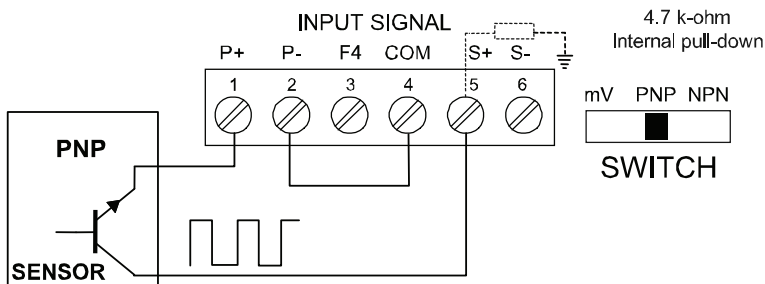

Figure 16: PNP Sensor Powered by Internal Supply

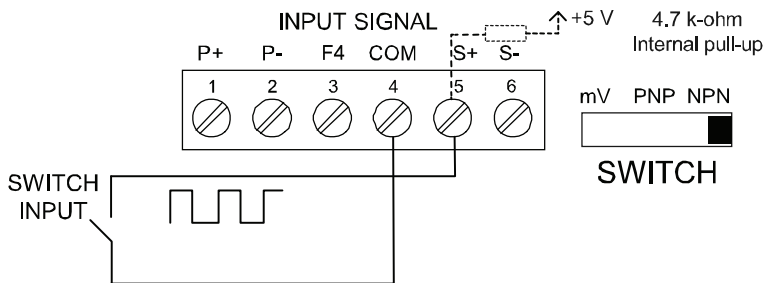

Figure 17: Switch Input Connections

Modbus RTU Serial Communications

Serial communications connection is made to an RJ45 connector labeled M-LINK on Figure 7. Use the YPPA1232 for RS-232 interfacing, the YPPA1485 for RS-485 interfacing, or the YPPA8008 for USB interfacing. The same port is used for interfacing with all expansion modules (e.g. external relays, digital I/O).

Use the YPPA1200 controller copy cable for meter-to-meter interfacing for cloning purposes (*i.e.* copying settings from one controller to other controllers).

Relay Connections

Relay connections are made to two six-terminal connectors labeled RELAY1 – RELAY4 on Figure 7. Each relay's C terminal is common only to the normally open (NO) and normally closed (NC) contacts of the corresponding relay. The relays' C terminals should not be confused with the COM (common) terminal of the INPUT SIGNAL connector.

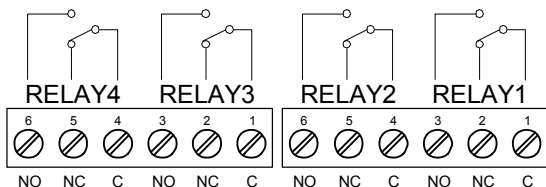

Figure 18: Relay Connections

Switching Inductive Loads

The use of suppressors (snubbers) is strongly recommended when switching inductive loads to prevent disrupting the microprocessor's operation. The suppressors also prolong the life of the relay contacts. Suppression can be obtained with resistor-capacitor (RC) networks assembled by the user or purchased as complete assemblies. Refer to the following circuits for RC network assembly and installation:

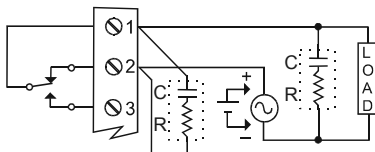

Figure 19: AC and DC Loads Protection

Choose R and C as follows:

R: 0.5 to 1 Ω for each volt across the contacts

C: 0.5 to 1 μF for each amp through closed contacts

Notes:

1. Use capacitors rated for 250 VAC.
2. RC networks may affect load release time of solenoid loads. Check to confirm proper operation.
3. Install the RC network at the controller's relay screw terminals. An RC network may also be installed across the load. Experiment for best results.

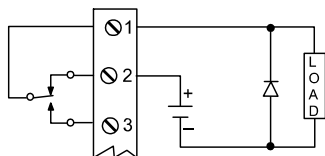

Use a diode with a reverse breakdown voltage two to three times the circuit voltage and forward current at least as large as the load current.

Figure 20: Low Voltage DC Loads Protection

RC Networks Available from Yokogawa

RC networks are available from Yokogawa and should be applied to each relay contact switching an inductive load. Part number: YPPX6901.

Note: Relays are de-rated to 1/14th HP (50 watts) with an inductive load.

F4 Digital Input Connections

A digital input, F4, is standard on the meter. This digital input connected with a normally open closure across F4 and COM, or with an active low signal applied to F4.

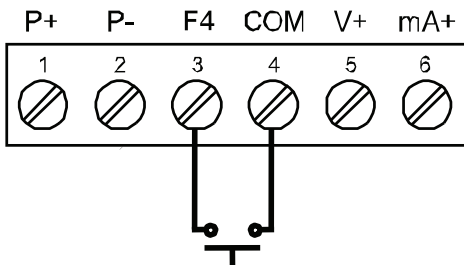

Figure 21: F4 Digital Input Connections

4-20 mA Output Connections

Connections for the 4-20 mA transmitter output are made to the connector terminals labeled MA OUT. The 4-20 mA output may be powered internally or from an external power supply.

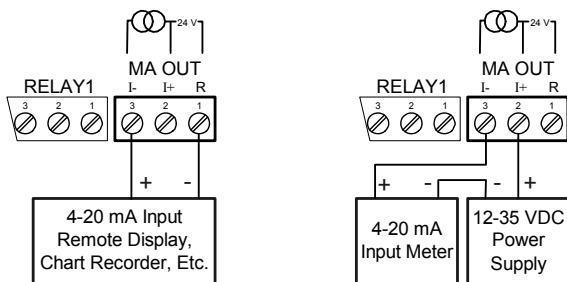

Figure 22: 4-20 mA Output Connections

Analog Output Transmitter Power Supply

The internal 24 VDC power supply powering the analog output may be used to power other devices, if the analog output is not used. The I+ terminal is the +24 V and the R terminal is the return.

External Relay & Digital I/O Connections

The relay and the digital I/O expansion modules YPPA1004 & YPPA1044 are connected to the controller using a CAT5 cable provided with each module. The two RJ45 connectors on the expansion modules are identical and interchangeable; they are used to connect additional modules to the system.

Note: The jumper located between the RJ45 connectors of the YPPA1044 must be removed on the second digital I/O module in order for the system to recognize it as module #2.



Do not connect or disconnect the expansion modules with the power on!
More detailed instructions are provided with each optional expansion module.

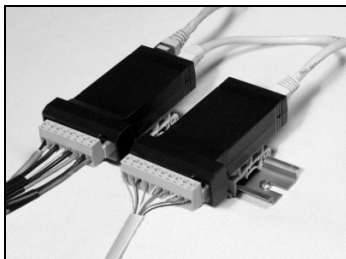

Figure 23: Expansion Modules & DIN Rail Mounting Kit

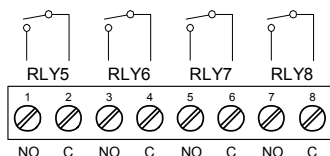

Figure 24: External Relays Module Connections

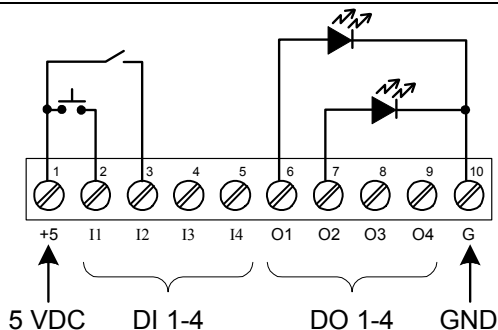

Figure 25: Digital I/O Module Connections

Interlock Relay Feature

As the name implies, the interlock relay feature reassigns one, or more, alarm/control relays for use as interlock relay(s). Interlock contact(s) are wired to digital input(s) and trigger the interlock relay. This feature is enabled by configuring the relay, and relative digital input(s) (see page 60). In one example, dry interlock contacts are connected in series to one digital input which will be used to force on (energize) the assigned interlock power relay when all interlock contacts are closed (safe). The interlock relay front panel LED flashes when locked out. The interlock relay would be wired in-series with the load (N/O contact). See below.

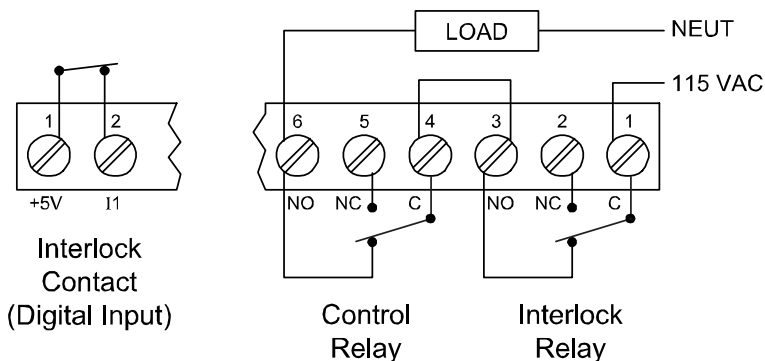

Figure 26: Interlock Connection

BASIC OPERATION AND PROGRAMMING

The YPP6210 is factory calibrated prior to shipment to read in milliamps and volts depending on the input selection. The calibration equipment is certified to NIST standards.

The YPP6310 has been factory calibrated to read input frequency in Hz (pulses/sec). The calibration equipment is certified to NIST standards.

Overview





Most setup and programming is done through the front panel buttons. The YPP6310 has one switch located to the right of the input connector, which must be configured according to the input level and type. Jumper J4 located inside the controller, behind the input signal connector, is used to select the excitation voltage (24 V*, 10 V or 5 V) which is supplied to the P+ and P- wiring terminals.

After power and input signal connections have been completed and verified, apply power to the controller.

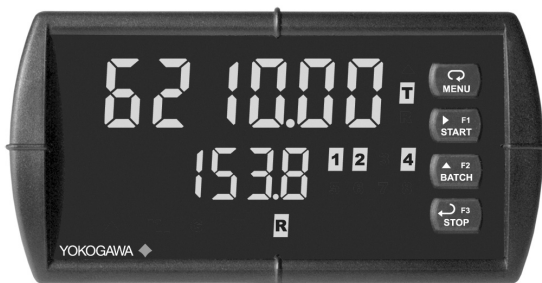
**Default Setting*

Front Panel Buttons and Status LED Indicators



Button Symbol	Description
	Menu
	START (Right arrow/F1)
	BATCH (Up arrow/F2)
	STOP (Enter/F3)
<p><i>Note:</i> F4 is a digital input. Alarms 5-8 enabled when relay expansion module is installed.</p>	

LED	Status
1-8	Relay 1 – 8 indicator
R	Rate indicator
T	Batch Total indicator
G T	Grand Total indicator
▲	Total overflow indicator
M	Manual control relays &/or analog output

Programming

- Press the Menu button to enter or exit the Programming Mode at any time.
- Press the Right arrow button to move to the next digit during digit or decimal point programming.
- Press or hold the Up arrow button to scroll through the menus, decimal point or press or hold to increment the value of a digit.
- Press the Enter button to access a menu or to accept a setting.
- Press and hold the Menu button for three seconds to access the advanced features of the controller.

Controller Operation

The YPP6210 controller is capable of accepting current (0-20 mA, 4-20 mA) and voltage signals (0-5 V, 1-5 V, 0-10 V, ± 10 V) and the YPP6310 accepts pulses (e.g. ± 40 mV to ± 8 V), square wave (0-5, 0-12V, or 0-24V), open collector NPN, PNP, TTL, or switch contact signals. These signals are scaled to represent rate in engineering units from -99999 to 999999. The pulse signals may be scaled with a K-factor to represent a total for the batch, and grand total.

The default configuration displays batch total on the upper display, and a selection of rate, grand total, batch count, and preset on the lower display.

When in pause or stop mode, the display will alternate the numeric value with the run status in the upper display and the display label for the lower display.

The controller has up to 4 relays on board (and 4 available with an external expansion module) which are used to either control the batch process in single or multi-stage batch control, or as alarms that will be active when the batch process is running. A 4-20 mA output option is also available for retransmitting the process variable analog or pulse signal.

Default Batch Control Operation

The following describes the operation of the three front panel operating keys as programmed with default settings.

START Button

Press the START button to begin a new batch process.

BATCH Button

Press the Batch button to access the Preset (batch amount) menu. Program the batch with the arrow keys, and confirm with the Enter key.

STOP Button

Press the STOP key once during a batch to pause. Press the STOP key while paused to stop and cancel the batch. Press the STOP key while in stop/ready mode cycle lower display values of rate (or other lower display programmed parameter), grand total, batch count, and preset.



Only STOP Button Enabled if a Batch is Running

During a batch process, only the pause/stop functions of the STOP button will function. No other buttons will be functional.

Batch Control Operation Example

The following example shows how two stage batch control functions with a YPP6210 or YPP6310. This setup will establish a 55 gallon preset for the batch, with a main valve (high flow) that will close at 50 gallons, and a trickle valve (low or restricted flow) that will close at 55 gallons. After the batch, the preset will be changed to 100 gallons.

Two-Stage Batch Control Setup Using Relays 1 & 2

The following table shows the parameters as they appear within the *SEtUP* menu entry *rELAY*.

Parameter	Setting	Function
<i>rELAY</i>	<i>ASSIGN</i>	Press Enter to enter the relay assignment parameters.
<i>ASSIGN1</i>	<i>TOTAL</i>	Assign relay 1 to batch total control.
<i>ASSIGN2</i>	<i>TOTAL</i>	Assign relay 2 to batch total control.
<i>PRECLOSE TOTAL</i>		Press Enter to access preclose selection for multi-stage control.
<i>PRECLOSE</i>	<i>YES</i>	Yes to enable a preclose value for relay 2.
<i>YES</i>	<i>000050</i>	Set the preclose value to 5 for closing the valve controlling relay 2 five gallons before reaching the preset.
<i>...</i>		Assignment for optional relays 3-8.
<i>RELAY 1 rELAY</i>		Select relay 1 setup.
<i>ACT 1 RELAY 1</i>		Configure activation of relay 1.
<i>ACT 1</i>	<i>AUTO</i>	Always set to Auto for batch control function.
<i>RELAY 1</i>	<i>PRESET</i>	Set the preset value for batch control.
<i>PRESET</i>	<i>000550</i>	Set 55 gallons as the preset.
<i>...</i>		Setup for optional relays 3-8.

The operation of relay 2 has already been assigned for multi-stage control preclose, and will not appear as a selection in the *rELAY* menu. If only one stage batch control was desired, with one relay for control, then one would set the assignment of relay 2, *ASSIGN2*, to off, rate, or grand total.

The following pages show an illustration of how the above settings control the batch operation. The display assignment is the default.

Batch Control Operation

1. A new container is prepared for the batch. Both valves are closed. Note that the upper display may show the batch total from the last batch.
2. The START button is pressed. Both valves open. The barrel begins to fill as the total being dispensed is displayed in the big window. The lower window shows the rate and units, alternating.
3. When the batch total reaches 50 gallons, the preset (55) minus the preclose amount (5) for relay 2, relay 2 deactivates to close the main valve. The barrel fills more slowly as a result, improving accuracy.
4. When the batch total equals the preset, relay 1 deactivates, closing valve 1. Filling stops.
5. The BATCH button is pressed, and a new preset is entered, 100 gallons, and the enter/STOP button is pressed to confirm it.
6. The new batch begins when the START button is pressed, so both relays activate and both valves open.

Additional Features

At any time during the batch, the STOP button may be pressed to pause the batch. When paused, the START button will continue the batch, and pressing the STOP button again will cancel the batch.

When in STOP mode, the STOP button may be pressed to cycle through alternative parameters to be displayed on the lower display, including the grand total, batch count, and preset.

The grand total and batch count may be reset in the *RESET* menu by pressing the MENU button and entering the reset menu. It may also be reset with digital inputs.

MANUAL MULTI-STAGE BATCH CONTROL OPERATION

System Setup

- Both valves are closed with an empty barrel in place. The batched total is displayed in the upper display, the preset is selected for the lower display.

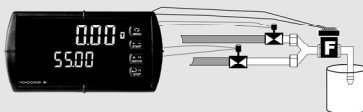

Batch Start

- The START button is pressed, with both valves open. The barrel begins to fill.

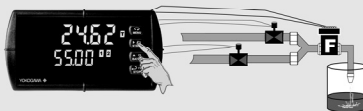

Preclose Valve

- When the batch total reaches a value of 50.00 (Preset[55.00] - Preclose[5.00]) the full-flow valve closes. The fill rate of the tank slows as a result.

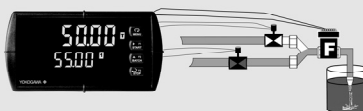

Completed Batch

- When the batch total equals the preset amount, the restricted-flow valve closes. The barrel is now full. If some overrun occurs, the next batch will adjust for this offset amount to maintain accuracy.

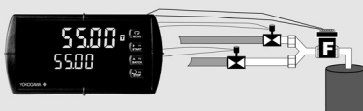

Change Preset

- After placing a new, empty barrel, a new preset fill amount may be selected with the BATCH key, while the process is stopped.



Begin New Batch

- Press the START key and a new batch will begin. With both valves open, the process continues.

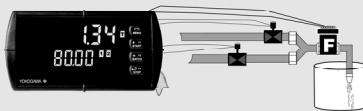

Pause/Stop

- At any time, the STOP button may be pressed, once to Pause the process, or twice to cancel the batch, which stops the process.

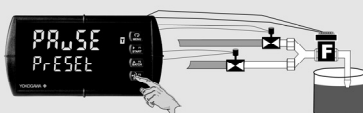

VALVE KEY LEGEND



Display Functions and Messages

The controller displays various functions and messages during setup, programming, and operation. The following table shows the main menu functions and messages in the order they appear in the menu.

Display	Parameter	Action/Setting Description
SEtUP	Setup	Enter Setup menu
INPut	Input	Enter Input selection menu
VolT	0-10 VDC	YPP6210 Only: Set input for ± 10 VDC input
mA	4-20 mA	YPP6210 Only: Set input for 4-20 mA input
toTAL	Total	Enable or disable totalizer features
un itS	Units	Select the display units/tags
rAtE	Rate	Select the display units for rate
toTAL	Total	Select the display units for total
GrANDtoTAL	Grand Total	Select the display units for grand total
dEc Pt	Decimal point	Set decimal point for rate, total, grand total
PRoG	Program	Enter the Program menu
INCAL	Input Calibration	Enter the Input Calibration menu
FRActor	K-factor Scaling	YPP6310 Only: Programs unit to convert input pulse to rate in engineering units
SCALE	Scale	Enter the Scale menu
CAL	Calibrate	Enter the Calibrate menu
INP 1	Input 1	Calibrate input 1 signal or program input 1 value
dis 1	Display 1	Program display 1 value
INP 2	Input 2	Calibrate input 2 signal or program input 2 value (up to 32 points)
dis 2	Display 2	Program display 2 value (up to 32 points)
Error	Error	Error, calibration not successful, check signal or programmed value
t Eb	Total time base	Enter totalizer time base for seconds, minutes, hours or day.
t CF	Total conversion	Enter the conversion factor decimal point

Model YPP6210 & YPP6310 Batch Controllers Instruction Manual

Display	Parameter	Action/Setting Description
	<i>factor</i>	and the conversion factor.
ጠ ሰደ	<i>Batch mode</i>	Automatic or manual batch control
ፔ ደሃ	<i>Time delay</i>	Set time delay for automatic batch restart
ፍፔ ፎፅ	<i>Grand total time base</i>	Program grand total time base
ፍፔ ርፑ	<i>Grand total conversion factor</i>	Program grand total conversion factor
ፍፔ ገረፔ	<i>Grand total reset</i>	Program grand total reset mode: auto or manual
dSPLY	<i>Display</i>	Enter the <i>Display</i> menu
ፅ ሰ	<i>Upper display</i>	Press Enter to assign the Upper display parameter (default: PV or rate)
ፊ ሰፎፎ	<i>Lower display</i>	Press Enter to assign the Lower display parameter (default: total)
d- ጠኔሃ	<i>Display intensity</i>	Set display intensity level from 1 to 8
rELAY	<i>Relay</i>	Enter the <i>Relay</i> menu
RSS ሰጠ	<i>Assignment</i>	Assign relays to rate, total (batch control), grand total, or Modbus controlled.
RS ሰጠ 1	<i>Assign 1</i>	Relay 1-2 assignment
ፎፎፎRL	<i>Total</i>	Assign relay to batch control
ፍፎፎፎRL	<i>Grand total</i>	Assign relay to grand total
ጠ ገፅ	<i>Modbus</i>	Assign relay to Modbus input
ገፎፎ	<i>Rate</i>	Assign relay to rate
PrEcLS	<i>Batch total relay preclose</i>	For relays beyond the first assigned to total, a preclose amount may be entered.
ገሃ 1	<i>Relay 1</i>	Relay 1 setup
Rፎፎ 1	<i>Action 1</i>	Set relay 1 action ¹
Rፅፆ	<i>Automatic</i>	Set relay for automatic reset
R-ጠ ገጠ	<i>Auto-manual¹</i>	Set relay for automatic & manual reset any time ¹ (relays assigned to rate)
LRፎፎ	<i>Latching¹</i>	Set relay for latching operation (relays assigned to rate) ¹

Model YPP6210 & YPP6310 Batch Controllers Instruction Manual

Display	Parameter	Action/Setting Description
Lt -CLr	Latching-cleared ¹	Set relay for latching operation with manual reset only after alarm condition has cleared (relays assigned to rate) ¹
ALtErn	Alternate ²	Set relay for pump alternation control (relays assigned to rate) ²
SRn PL	Sampling	Set relay for sampling operation (rate or GT)
OFF	Off	Disable relay and front panel status LED (Select Off to enable Interlock feature)
PrESEt	Preset	Set batch preset
SEt 1	Set 1	Program set point 1
rSEt 1	Reset 1	Program reset point 1
rLY 2	Relay 2	Relays 2-8 setup. Relays 5-8 are shown, only if expansion relay module is installed.
FR iLSF	Fail-safe	Enter <i>Fail-safe</i> menu
FLS 1	Fail-safe 1	Set relay 1 fail-safe operation
on	On	Enable fail-safe operation
oFF	Fail-safe off	Disable fail-safe operation
dELAY	Delay	Enter relay <i>Time Delay</i> menu
dLY 1	Delay 1	Enter relay 1 time delay setup
On 1	On	Set relay 1 On time delay
OFF 1	Off	Set relay 1 Off time delay
brERH	Loop break	Set relay condition if loop break detected (For mA input only)
iGnorE	Ignore	Ignore loop break condition (Processed as a low signal condition)
On	On	Relay goes to alarm condition when loop break is detected
OFF	Off	Relay goes to non-alarm condition when loop break is detected
Rout	Analog output	Enter the <i>Analog output</i> scaling menu
d iS 1	Display 1	Program display 1 value
Out 1	Output 1	Program output 1 value (e.g. 4.000 mA)
d iS 2	Display 2	Program display 2 value

Model YPP6210 & YPP6310 Batch Controllers Instruction Manual

Display	Parameter	Action/Setting Description
0ut 2	Output 2	Program output 2 value (e.g. 20.000 mA)
rESEt	Reset	Press Enter to access the <i>Reset</i> menu
rSt Hi	Reset high	Press Enter to reset max display
rSt Lo	Reset low	Press Enter to reset min display
rSt HL	Reset high & low	Press Enter to reset max & min displays
rSt t	Reset total	Press Enter to reset total
rSt Gt	Reset grand total	Press Enter to reset grand total
rSt bc	Reset batch count	Press Enter to reset batch count
Control	Control	Enter <i>Control</i> menu
Auto	Automatic	Press Enter to set controller for automatic operation
Man	Manual	Press Enter to manually control relays or analog output operation
PRSS	Password	Enter the <i>Password</i> menu
PRSS 1	Password 1	Set or enter Password 1
PRSS 2	Password 2	Set or enter Password 2
PRSS 3	Password 3	Set or enter Password 3
totRL	Total password	Set or enter password for manual reset
GtotRL	Grand total password	Set or enter password for manual reset
nonrSt	Non-resettable	Non-resettable grand total set after entering "050873" for Gtotal password
unLoc	Unlocked	Program password to lock controller
Locd	Locked	Enter password to unlock controller
999999 -99999	Flashing display	Overrange condition Underrange condition

1. During operation, only the STOP button will function, to stop/pause the batch. As a result, relay alarms cannot be manually reset.
2. This setting used for level control applications. It is not appropriate if using this controller for batching applications.

Main Menu Map

The main menu consists of the most commonly used functions: *Setup*, *Reset*, *Control*, and *Password*.

- Press Menu button when a batch is not running to enter Programming Mode then press the Up arrow button to scroll main menu.

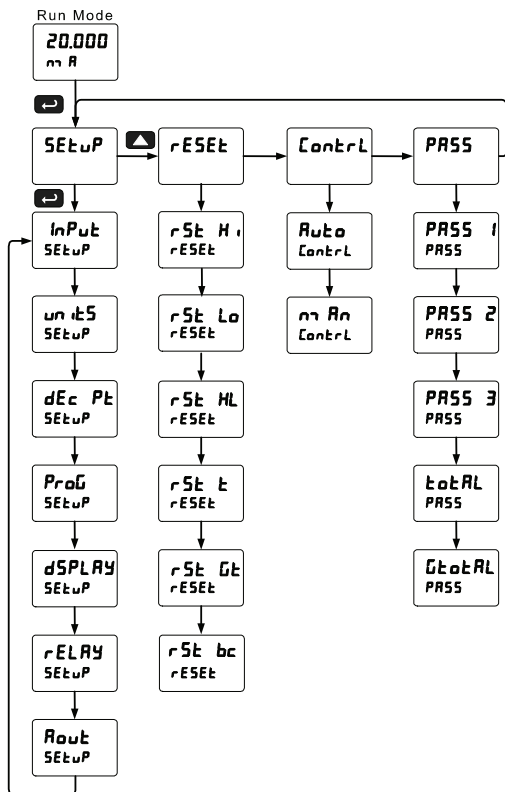

- Press Menu, at any time, to exit and return to Run Mode. Changes made to settings prior to pressing Enter are not saved.
- Changes to the settings are saved to memory only after pressing Enter.
- The display moves to the next menu every time a setting is accepted by pressing Enter.

Setting Numeric Values

The numeric values are set using the Right and Up arrow buttons. Press Right arrow to select next digit and Up arrow to increment digit value.

The digit being changed is displayed brighter than the rest.

Press and hold up arrow to auto-increment the display value.

Press the Enter button, at any time, to accept a setting or Menu button to exit without saving changes.

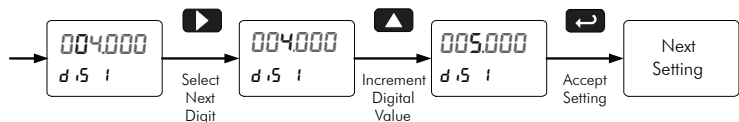

Setting Up the Batch Controller (SEtUP)

The *Setup* menu is used to select:

1. Input signal the controller will accept
2. Enable or disable totalizer and batching features
3. Select the display units/tags
4. Decimal point position
5. Program menu for scaling or calibration
6. Display parameter and intensity
7. Relay operation
8. 4-20 mA analog output scaling

Press the Enter button to access any menu or press Up arrow button to scroll through choices. Press the Menu button to exit at any time.

Please reference the “Setup” flow chart on the following page in order to view the Setup Menu hierarchy for both the YPP6210 and YPP6310.

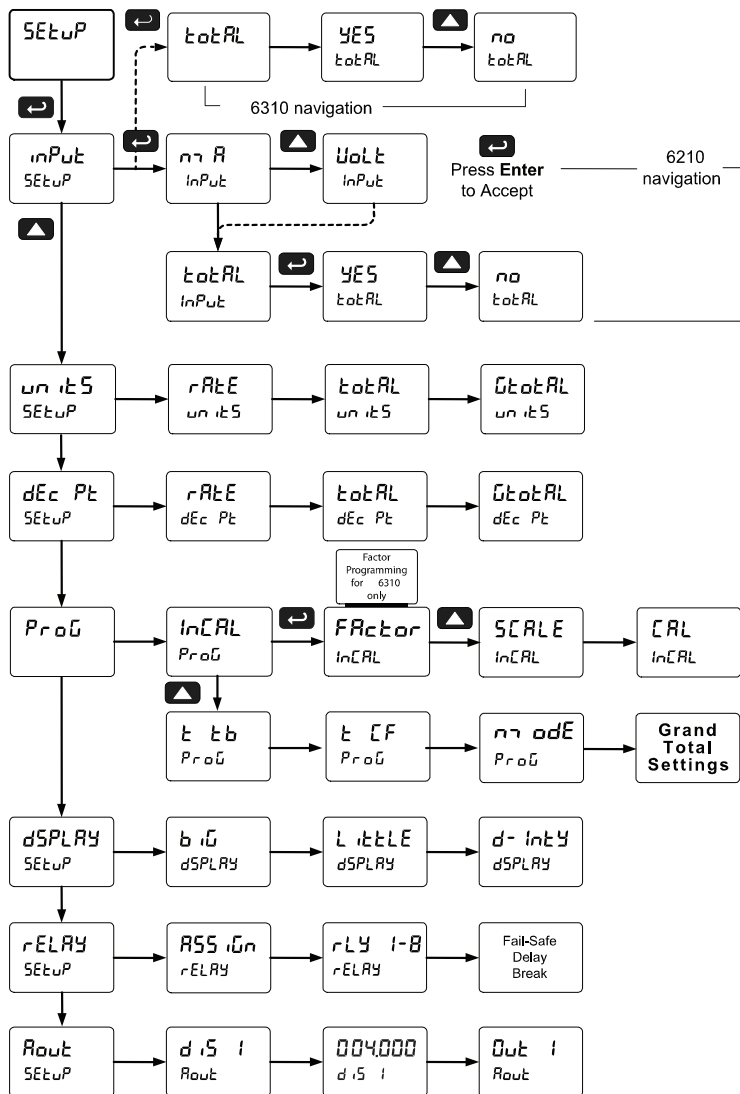

Scaling and Calibration

It is very important to read the following information, before proceeding to program the controller:

- There is **no need to recalibrate** the controller when first received from the factory.
- All inputs are factory calibrated. The calibration equipment used is certified to NIST standards.
- Use the *Scale* menu to enter the scaling without a signal source.
- Use the *Calibrate* menu to apply a signal from a calibrator or a flowmeter for the scaling.

Setting the Input Signal (*Input*)

YPP6210: Enter the *Input* menu to set up the controller to display current (*mA*) or voltage (*V*) inputs.

The current input is capable of accepting any signal from 0 to 20 mA. Select current input to accept 0-20 mA or 4-20 mA signals.

The voltage input is capable of accepting any signal from -10 to +10 VDC. Select voltage input to accept 0-5, 1-5, 0-10, or ± 10 VDC signals.

YPP6310: There is a switch, located to the right of the input connector, which must be configured according to the input level and type. Jumper J4 located inside the controller, behind the input signal connector, is used to select the excitation voltage (24 V*, 10 V or 5 V) which is supplied to the P+ and P- wiring terminals.

The controller may be calibrated using the *K-Factor* function. Most flowmeter manufacturers provide this information with the device. Enter the *K-Factor* (*Factor*) menu and select the decimal point with highest resolution possible and program the K-factor value (*i.e.* pulses/gal). The controller will automatically calculate the flow rate using the K-factor and the time base selected.

**Default setting*

Setting the Totalizer and Batching Features (*Totalizer*)

After the input type is entered, set the *Totalizer* parameter to "YES" to enable batch control (this is set by default). If the *Totalizer* features are disabled, most batching features and functions are hidden from the menus.

Setting the Input Units or Custom Tags (ун ѓ5)

Enter the input unit or custom tag that will be displayed if alternating rate, total, or grand total and units is selected in the ун ѓ5 menu, or d ун ѓ is selected as the Lower display parameter. See the flow chart on page 53 to access the display menu to show the unit or tag on the Lower display. The engineering units or custom legends can be set using the following 7-segment character set:

Display	Character
0	0
1	1
2	2
3	3
4	4
5	5
6	6
7	7
8	8
9	9
A	A
b	b
C	C
c	c
d	d
E	E
F	F
G	G
g	g
H	H
h	h
I	I
i	i
J	J

Display	Character
K	K
L	L
m	m
n	n
O	O
o	o
P	P
q	q
r	r
S	S
t	t
u	u
V	V
w	w
X	X
Y	Y
Z	Z
-	-
/	/
]]
[[
=	=
Degree(<)	Degree(<)
Space	Space

Notes:

Degree symbol represented by (<) if programming with PROPLUS.

The letters "m" and "w" use two 7-segment LEDs each; when selected the characters to the right are shifted one position.

Press and hold up arrow to auto-scroll the characters in the display.

Setting the Decimal Point (dEc Pt)

The decimal point may be set with up to five decimal places or with no decimal point at all. The rate, total, and grand total decimal points are independent.

Press the Up arrow to move the decimal point one place to the left.
 Press the Right arrow to move the decimal point one place to the right.

Programming the Batch Controller (PrOG)

It is **very important** to read the following information, before proceeding to program the controller:

- The YPP6210 is factory calibrated prior to shipment to read in milliamps and volts depending on the input selection. The calibration equipment is certified to NIST standards.
- The YPP6310 has been factory calibrated to read input frequency in Hz (pulses/sec). The calibration equipment is certified to NIST standards.
- Use the K-Factor in the YPP6310 menu to match the rate/totalizer with a flowmeter's k-factor (pulse/unit of measure).
- Use the *Scale* menu to scale process inputs without a signal source. A calibrated signal source is not needed to scale the controller.

The *Program* menu contains the following menus:

1. Enter K-Factor (YPP6310 only)
2. Scale without a signal source
3. Calibrate with a calibrated signal source
4. Total time base & conversion factor
5. Grand total time base & conversion factor
6. Total reset mode for total & grand total

The process inputs may be calibrated or scaled to any display value within the range of the controller.

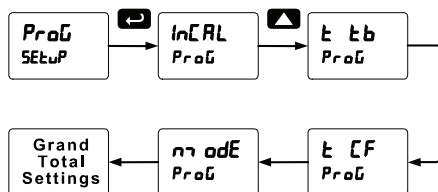

Additional parameters, not needed for most applications, are programmed in the *Advanced Features* menu; see **ADVANCED OPERATION AND PROGRAMMING**, page 70.

Model YPP6210 & YPP6310 Batch Controllers Instruction Manual

Input Calibration Method (InCAL)

There are three methods of calibrating (or scaling) the display to show the correct engineering units.

- Use the *Factor* menu to enter a K-Factor. (Pulse input models only.)
- Use the *Scale* menu to enter the scaling without a signal source.
- Use the *Calibrate* menu to apply a signal from a signal source.

Note: The K-Factor, Scale, and Calibrate functions are exclusive of each other. The meter uses the last function programmed. Only one of these methods can be employed at a time. The Scale and Calibrate functions can use up to 32 points (default is 2). The number of points should be set for Scale and Calibrate accordingly under the Number of Points (nOPtS) menu selection prior to scaling and calibration of the meter, see page 78 for details.

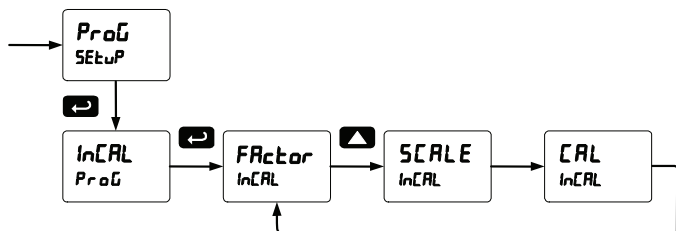

YPP6310 Only: K-Factor Calibration (FRctor)

The meter may be calibrated using the *K-Factor* function. Most flowmeter manufacturers provide this information with the device. Enter the *K-Factor* (FRctor) menu and select the decimal point with highest resolution possible and program the k-factor value (i.e. pulses/gal). The meter will automatically calculate the flow rate using the k-factor and the time base selected.



Model YPP6210 & YPP6310 Batch Controllers Instruction Manual

Scaling the Controller (SCALE)

The process inputs (4-20 mA and ± 10 VDC) and frequency inputs can be scaled to display the process variable in engineering units.

A signal source is not needed to scale the controller; simply program the inputs and corresponding display values.

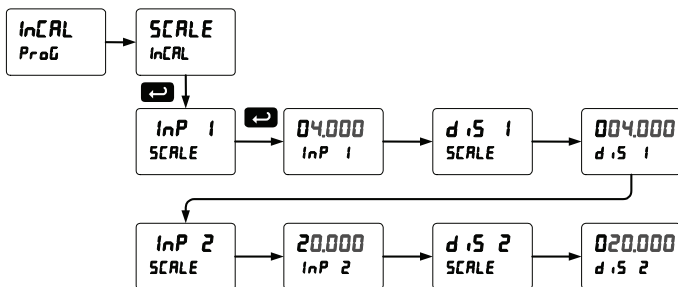

For instructions on how to program numeric values see *Setting Numeric Values*, page 43.

Error Message (Error)

An error message indicates that the calibration or scaling process was not successful.

After the error message is displayed, the controller reverts to input 2 during calibration or scaling and to input 1 during internal calibration, allowing the appropriate input signal to be applied or programmed.

The error message might be caused by any of the following conditions:

1. Input signal is not connected to the proper terminals or it is connected backwards.
2. Wrong signal selection in *Setup* menu.
3. Minimum input span requirements not maintained.
4. Input 1 signal inadvertently applied to calibrate input 2.

Minimum Input Span

The minimum input span is the minimum difference between input 1 and 2 signals required to complete the calibration or scaling of the controller.

Input range	Input 1 & input 2 span
4-20 mA	0.15 mA
± 10 VDC	0.10 VDC

Model YPP6210 & YPP6310 Batch Controllers Instruction Manual

Time Base, Total Conversion Factor & Total Reset

The time base, total conversion factor, and total reset menus are located in the *Program* menu.

The total and grand total have their own independent settings. This means that one can be displaying the value in gallons while the other displays in million gallons, liters, m³, etc.

Batch Start Mode (ה adE)

The batch controller may operate in manual or automatic mode. In manual mode, the controller operates as defined in Controller Operation as described on page 34. In automatic mode, the batch process will automatically begin after a completed batch. The time delay for the restart may be 0.1 to 999.9 seconds (t dLY). Automatic batch start will only occur after a successful batch. A manually stopped batch will require a manual start to begin a new batch process.

Grand Total Reset

The grand total can be programmed for manual or automatic reset. In the automatic reset mode, a programmable time delay is available to reset the grand total after the assigned preset is reached.

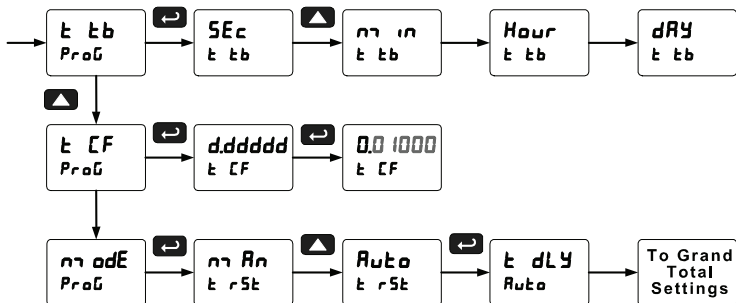

Non-Resettable Totalizer

The total and grand total can be password-protected to prevent unauthorized resets. The grand total can be programmed as a non-resettable total, see page 69 for details.

Model YPP6210 & YPP6310 Batch Controllers Instruction Manual

Calibrating the Controller with External Source (CAL)

To scale the controller without a signal source refer to Scaling the Controller (SCALE) page 48.

The controller can be calibrated to display the process variable in engineering units by applying the appropriate input signal and the corresponding display value.

The use of a calibrated signal source is strongly recommended to calibrate the controller.

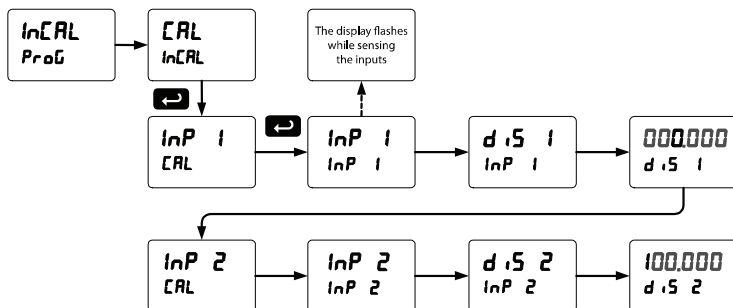

Warm up the controller for at least 15 minutes before performing calibration to ensure specified accuracy.

Setting the Display Parameter & Intensity (dSPLEAY)

The Upper display (b \bar{U}) can be programmed to display:

1. Display total
2. Display grand total
3. Toggle rate and total
4. Toggle rate and grand total
5. Display batch count
6. Relay set points
7. Toggle preset and rate
8. Toggle rate and units
9. Toggle total and units
10. Toggle grand total and units
11. Display max and min values
12. Display Modbus input
13. Display rate value

The Lower display (L \bar{LLE}) can be programmed to display:

1. Toggle rate and units
2. Toggle total and units
3. Toggle grand total and units
4. Display max and min values
5. Display Modbus input
6. Off (no display)
7. Display rate units
8. Display rate
9. Display total
10. Display grand total
11. Toggle rate and total
12. Toggle rate and grand total
13. Display batch count
14. Relay set points
15. Toggle preset and rate

Display Intensity: The meter has eight display intensity levels to give the best performance under various lighting conditions. Select intensity 8 for outdoor applications. The default intensity setting is 8.

For direct sunlight readability, Sunbright display models are highly recommended. See Ordering Information on page 7 for details.

Display Setup Menu

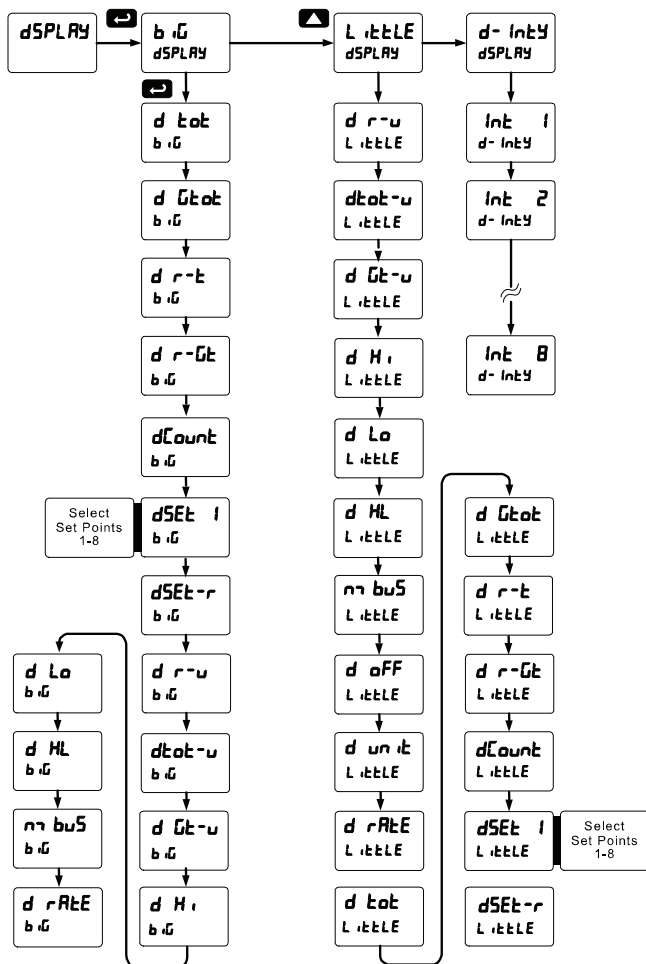

After setting up the input and the display, press the Menu button to exit programming and skip the rest of the setup menu. Press the Menu button again and the Up arrow to reach the *Program* menu and complete the scaling or calibration of the meter.

Setting the Relay Operation (rELAY)

This menu is used to set up the operation of the relays.



Caution!

During setup, the relays do not follow the input and they will remain in the state found prior to entering the Relay menu.

1. Relay assignment
 - a. Rate for low and high alarm
 - b. Total for batch control relays
 - c. Grand total for grand total alarms
2. Relay action
 - a. Automatic reset only (non-latching)
 - b. Automatic + manual reset when not in a batch process (non-latching)
 - c. Latching (manual reset when not in a batch process only)
 - d. Latching with Clear (manual reset when not in a batch process only after alarm condition has cleared)
 - e. Pump alternation control (automatic reset only, for level applications unrelated to batch control)
 - f. Sampling (the relay is activated for a user-specified time and may be assigned to rate or grand total)
 - g. Off (relay state controlled by Interlock feature)
3. Set and reset points; batch preset
4. Fail-safe operation
 - a. On (enabled)
 - b. Off (disabled)
5. Time delay
 - a. On delay (0-999.9 seconds)
 - b. Off delay (0-999.9 seconds)
6. Relay action for loss (break) of 4-20 mA input (ignore, on, off)

Note: Fail-safe should not be used for relays assigned to batch control.



Rate Alarms Only Active During a Batch Process

The rate alarms are active only during a batch process. As a result, rate alarms should not be programmed with manual reset, as they cannot be manually reset during a batch process, the only time they are active.

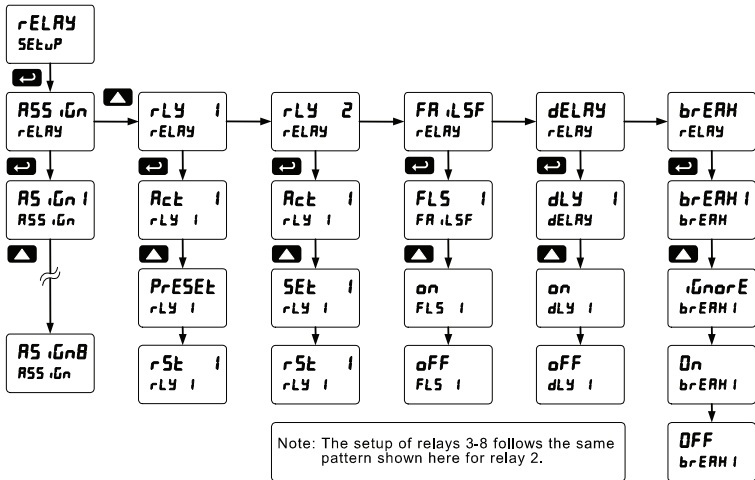

Relay Assignment (ASSIGN)

The relays can be assigned to any of the following parameters:

1. Rate for low or high alarm indication
2. Total for batch control relays
3. Grand total for alarm indication

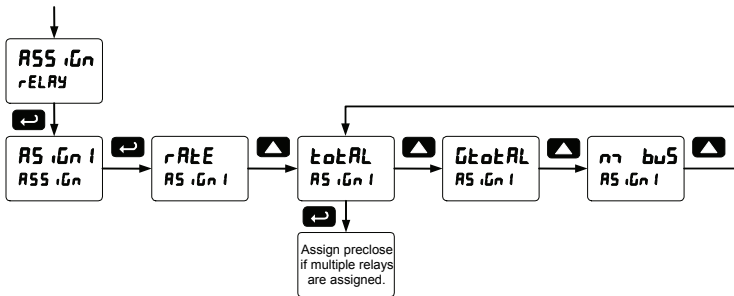

Note: Relay 1 should always be assigned to “total” for batch control applications.

Setting the Relay Action

Operation of the relays is programmed in the *Action* menu. The relays are commonly set up for any of the following modes of operation:

1. Always set to Auto for Batch control operation. Also for automatic reset (non-latching) of alarms.
2. Sampling (the relay is activated for a user-specified time)
3. Off (relay state controlled by Interlock feature)

In addition, the following relay actions may be programmed. These actions are not appropriate for batch control applications, but may be used when the controller is in other applications.

4. Automatic + manual reset when not in a batch process (non-latching)
5. Latching (manual reset only, when not in a batch process)
6. Latching with Clear (manual reset only when not in a batch process after alarm condition has cleared)
7. Pump alternation control (automatic reset only, for level applications, unrelated to batch control.)

Setting Batch Control Relays

Operation of batch control relays are programmed in the *Assign* menu by selecting *EOERL* as the assignment. Relays set to *EOERL* beyond the first will include a preclose parameter (*PRECLS*) option. Selecting *YES* for *PRECLS* will enable multi-stage batching with preclose, and the valve will close prior to the end of the batch at volume equal to the preset value minus the preclose amount entered. Selecting *NO* for *PRECLS* will have the relay perform identically to the first batch control relay set to *EOERL*.

Programming Alarm Set and Reset Points

High alarm indication: program set point above reset point.

Low alarm indication: program set point below reset point.

The deadband is determined by the difference between set and reset points. Minimum deadband is one display count. If the set and reset points are programmed with the same value, the relay will reset one count below the set point.

Note: Changes are not saved until the reset point has been accepted.

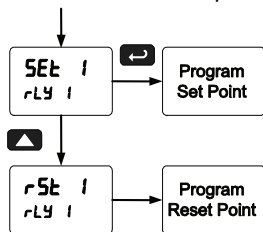

Setting Fail-Safe Operation

In fail-safe mode of operation, the relay coil is energized when the process variable is within safe limits and the relay coil is de-energized when the alarm condition exists. The fail-safe operation is set independently for each relay. Select **on** to enable or select **oFF** to disable fail-safe operation. Failsafe mode should not be used on batch relays assigned to total.

Programming Time Delay

The *On* and *Off* time delays may be programmed for each relay between 0 and 999.9 seconds. The relays will transfer only after the condition has been maintained for the corresponding time delay.

The *On* time delay is associated with the set point.

The *Off* time delay is associated with the reset point.

Relay Action for Loss of 4-20 mA Input (Loop Break)

The loop break feature is associated with the 4-20 mA input. Rate alarm relays may be programmed to go to one of the following conditions when the controller detects the loss of the input signal (i.e. < 0.005 mA):

1. Turn *On* (Go to alarm condition)
2. Turn *Off* (Go to non-alarm condition)
3. Ignore (Process as a low signal condition)

Note: This is not a true loop break condition; if the signal drops below 0.005 mA, it is interpreted as a "loop break" condition.

Relay Operation Details

Overview

The relays of the controller can serve three roles, as batch control relays for single or multi-stage batching, as rate, or grand total alarm, or as a sampling relay based on grand total or rate alarm.

These capabilities include front panel alarm status LEDs and 2 or 4 internal relays and/or 4 external relays expansion module.

The relays used for batch control (total) are activated when the batching process starts, and deactivate when the batch total is reached, minus any preclose amount programmed for batch (total) relays after the first.

For an example of batch control operation, see Batch Control Operation Example on page 35.

Typical applications for alarms are low and high flow alarms or grand total limit alarms. Note that rate alarms are only enabled during a batching process, and deactivate when the processes is stopped.

The relays can also be set for sampling, where the relay will activate for a specific amount of time after a certain grand total has been reached (ie: 2 second sample relay activation every 100 gallons batched).

There are three basic ways the relays can be used:

1. Batch Control (Total)
2. High or Low Alarms for Rate or Grand Total
3. Sampling (Based on Grand Total and Sample Time)

Relays Initialization

Batch control (total) relays will activate when the start function is enabled, such as when the START button is pressed. Rate alarm relays will enable and initialize to their programmed states when the batch process is started. Grand total alarm relays will initialize to their programmed state at controller power-up.

Fail-Safe Operation

The following table indicates how alarm relays behave based on the fail-safe selection for each relay:

Fail-Safe Selection	De-Energized State		Energized State		Power Failure
	NO	NC	NO	NC	
Off	Open	Closed	Closed	Open	Relays in de-energized state
On	Closed	Open	Open	Closed	Relays in energized state

Note: NO = Normally Open, NC = Normally Closed. This refers to the condition of the relay contacts when the power to the controller is off.

Front Panel LEDs

The LEDs on the front panel provide status indication for the following:

LED	Status
1	Alarm 1
2	Alarm 2
3	Alarm 3
4	Alarm 4

LED	Status
5	Alarm 5
6	Alarm 6
7	Alarm 7
8	Alarm 8

The controller is supplied with four alarm points that include front panel LEDs to indicate alarm conditions. This standard feature is particularly useful for alarm applications that require visual-only indication. The LEDs are controlled by the set and reset points programmed by the user. When the display reaches a set point for a high or low alarm, the corresponding alarm LED will turn on. When the display returns to the reset point the LED will go off. Note that rate alarms are only enabled during a batching process, and deactivate when the processes is stopped.

Latching relays, or relays with manual reset, are not recommended when using this controller for batch control, as the manual reset will not be acknowledged during a batch process, when the rate alarms are active. For information on latching and manual reset alarms, see the YPP6200 and YPP6300 instruction manuals available at www.yokogawa-usa.com.

Automatic Reset (Auto)

Automatic reset only

Condition	LED	Relay
Normal	Off	Off
Alarm	On	On
Ack (No effect)	On	On
Normal	Off	Off

In this application, the controller is set up for automatic reset (non-latching relay). Acknowledging the alarm while it is still present has no effect on either the LED or the relay. When the alarm finally goes away, the relay automatically resets and the LED also goes off.

Pump Alternation Control

Pump alternation control is not recommended when using this controller for batch control, as it is used only in level applications, and not with rate, total, or batching applications. For information on using pump alternation control for level, see the YPP6200 and YPP6300 instruction manuals available at www.yokogawa-usa.com.

Setting Up the Interlock Relay (Force On) Feature

Relays 1-4 can be set up as interlock relays. To set up the relays for the interlock feature:

1. Access the *Setup – Relay – Action* menu and set the action to off.

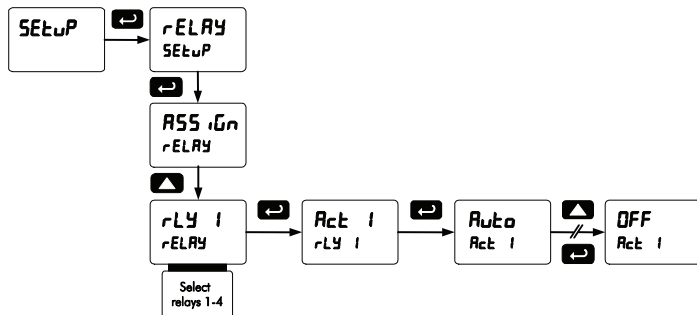

2. In the Advanced features – *User* menu program any of the digital inputs to Force On any of the internal relays (1-4).

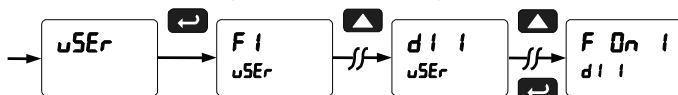

3. Connect a switch or dry contact between the +5V terminal and the corresponding digital input (DI-1 to DI-4) terminal.

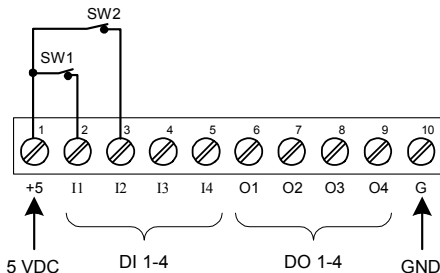

Interlock Relay Operation Example

Relays 3 & 4 are configured to energize (their front panel LEDs are off) when SW1 & SW2 switches (above) are closed. If the contacts to these digital inputs are opened, the corresponding front panel LEDs flash indicating this condition. The processes being controlled by the interlock relay will stop, and will re-start only after the interlock relay is re-activated by the digital inputs (switches).

Sample Relay Operation

The sampling function allows the operator to set a set point for a “sampling” relay. This can be done for the rate, total, or grand total. Each time the relay reaches the set point, it will close that relay’s contacts for a programmed period of time

A rate sampling relay will activate for the sample time ($SR_{n-1} \cdot t$), up to 600.0 seconds, every time the set point rate is reached.

A total sampling relay will activate for the sample time ($SR_{n-1} \cdot t$), up to 600.0 seconds every time the process has batched the amount programmed for the set point, and every time this amount has been batched afterward. (See the diagram below for more details). The utility of this function can, of course, be expanded beyond sampling and be used whenever a timed relay output closure is required when the batch total interval reaches a certain set point.

Relay and Alarm Operation Diagrams

The following graphs illustrate the common operation of the relays, status LEDs, and ACK button.

High Alarm Operation (Set > Reset)

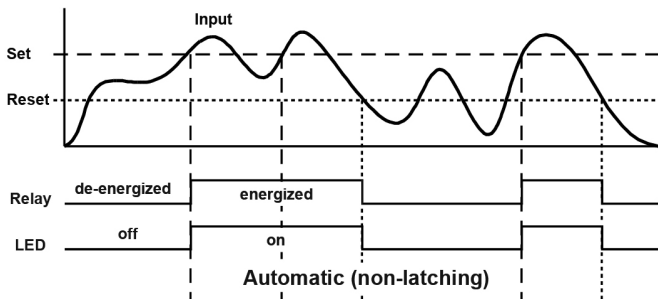

Low Alarm Operation (Set < Reset)

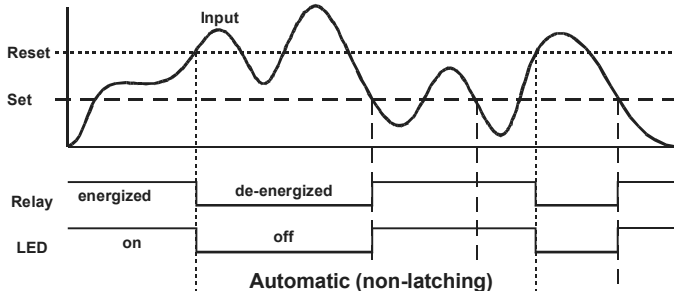

High Alarm with Fail-Safe Operation (Set > Reset)

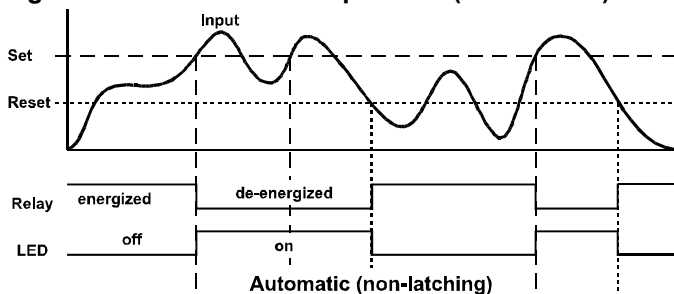

*Note: Relay coil is energized in non-alarm condition.
In case of power failure, relay will go to alarm state.*

Low Alarm with Fail-Safe Operation (Set < Reset)

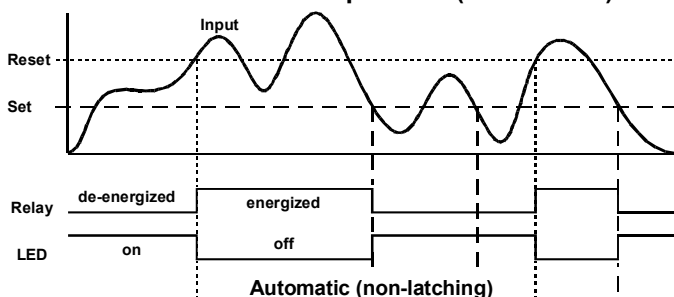

*Note: Relay coil is energized in non-alarm condition.
In case of power failure, relay will go to alarm state.*

Rate Relay Sampling Operation

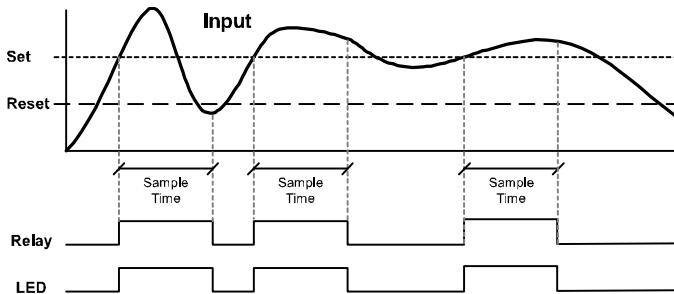

When the signal crosses the set point, the relay trips and the sample time starts. After the sample time has elapsed, the relay resets. The cycle repeats every time the set point is crossed, going up for high alarms and going down for low alarms.

The sample time can be programmed between 0.1 and 600.0 seconds.

Total Relay Sampling Operation

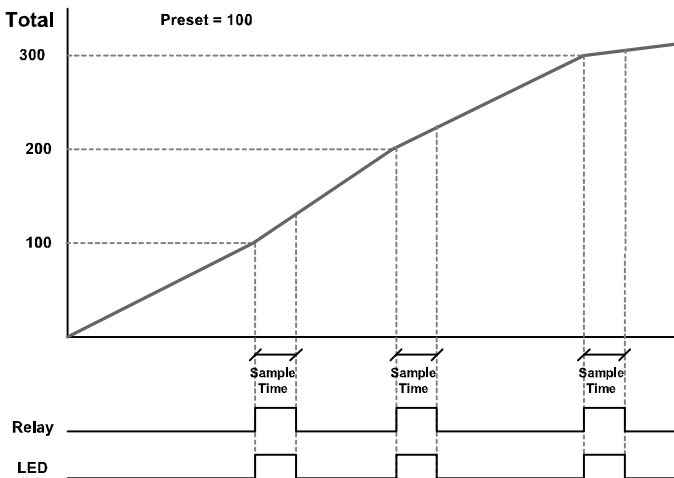

When the batch total reaches the set point, the relay trips and the sample time starts. After the sample time has elapsed, the relay resets. The cycle repeats every time the set point value is added to the batch total.

Signal Loss or Loop Break Relay Operation

The following graph shows the loop break operation for a high alarm relay.

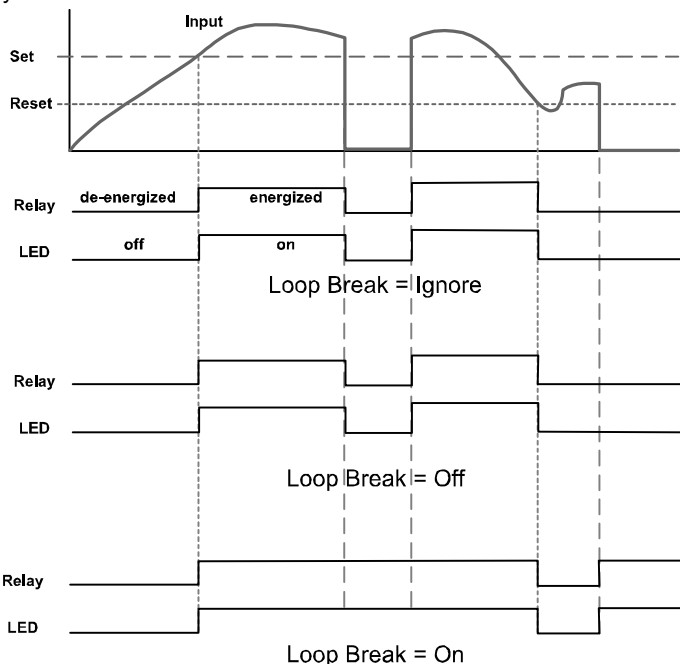

When the controller detects a break in the 4-20 mA loop, the relay will go to one of the following selected actions:

1. Turn on (Go to alarm condition)
2. Turn off (Go to non-alarm condition)
3. Ignore (Process as a low signal condition)

Time Delay Operation

The following graphs show the operation of the time delay function.

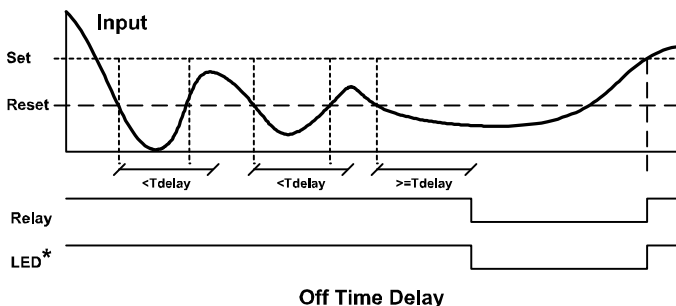
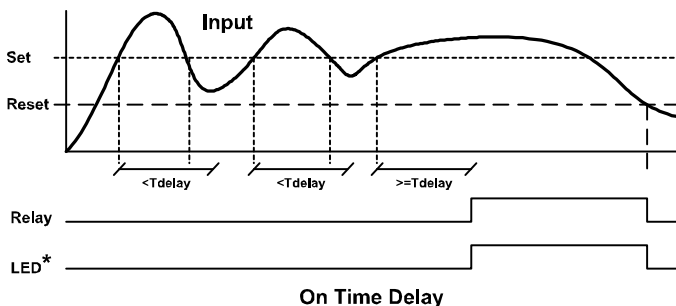

When the signal crosses the set point, the *On* time delay timer starts and the relay trips when the time delay has elapsed. If the signal drops below the set point (high alarm) before the time delay has elapsed, the *On* time delay timer resets and the relay does not change state. The same principle applies to the *Off* time delay.

Note: If "Automatic or Manual (R-n Rn)" reset mode is selected, the LED follows the reset point and not the relay state when the relay is acknowledged.

Scaling the 4-20 mA Analog Output (R_{out})

The 4-20 mA analog output can be scaled to provide a 4-20 mA signal for any rate display range selected.

No equipment is needed to scale the analog output; simply program the display values to the corresponding mA output signal.

The *Analog Output* menu is used to program the 4-20 mA output based on rate display values.

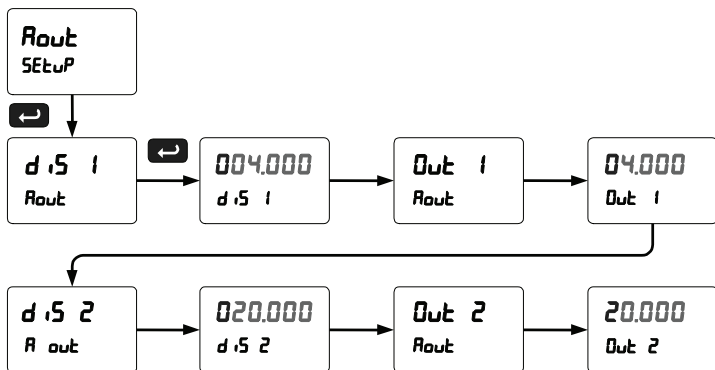

For instructions on how to program numeric values see *Setting Numeric Values*, page 43.

Reset Menu (rE5Et)

The *Reset* menu is used to reset the total, grand totals, batch count, maximum, or minimum reading (peak or valley) reached by the process; both maximum and minimum may be reset at the same time by selecting “reset high & low” (r5t HL).

Control Menu (ContrL)

The *Control* menu is used to control the 4-20 mA analog output and the relays manually, ignoring the input. Each relay and analog output can be programmed independently for manual control. Selecting automatic control sets all relays and analog output for automatic operation.

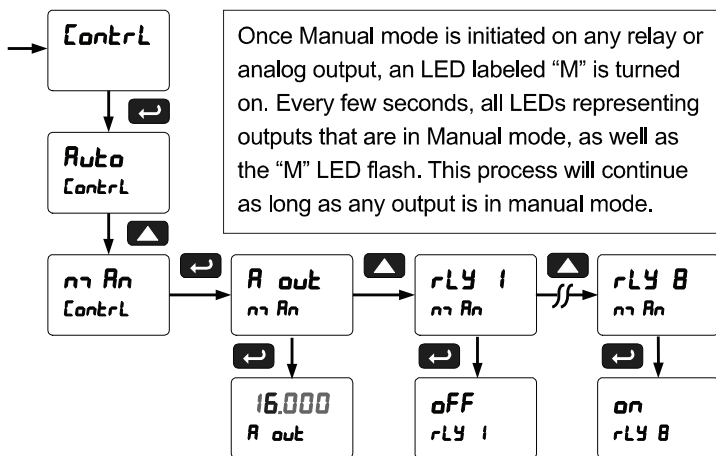

Setting Up the Password (PASS)

The *Password* menu is used for programming three levels of security to prevent unauthorized changes to the programmed parameter settings and to program the non-resettable totalizer.

- Pass 1: Allows use of function keys and digital inputs
- Pass 2: Allows use of function keys, digital inputs and editing set/reset points
- Pass 3: Restricts all programming, function keys, and digital inputs.
- Total Password: Prevents resetting the total manually
- Gtotal Password: Prevents resetting the grand total manually

Protecting or Locking the Controller

Enter the *Password* menu and program a six-digit password.

For instructions on how to program numeric values see *Setting Numeric Values*, page 43.

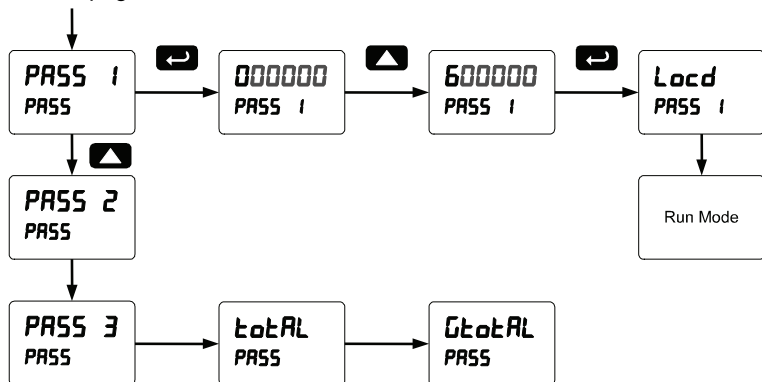

Record the password for future reference. If appropriate, it may be recorded in the space provided.

Model:	
Serial Number:	
Password 1:	_____
Password 2:	_____
Password 3:	_____
Total	_____
GTotal	_____

Grand Total Reset Password & Non-Resettable Total

The grand total can be password-protected to prevent unauthorized total resets.

The grand total can be programmed as a non-resettable total by entering the password "050873".



Caution!

Once the Grand Total has been programmed as "non-resettable" the feature **cannot** be disabled.

Making Changes to a Password Protected Controller

If the controller is password protected, the controller will display the message *Lacd* (Locked) when the Menu button is pressed. Press the Enter button while the message is being displayed and enter the correct password to gain access the menu. After exiting the programming mode, the controller returns to its password protected condition.

Disabling Password Protection

To disable the password protection, access the *Password* menu and enter the correct password twice, as shown below. The controller is now unprotected until a new password is entered.

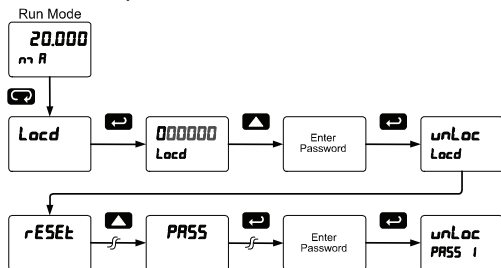

If the correct six-digit password is entered, the controller displays the message *unLac* (unlocked) and the protection is disabled until a new password is programmed.

If the password entered is incorrect, the controller displays the message *Lacd* (Locked) for about two seconds, and then it returns to Run Mode. To try again, press Enter while the *Locked* message is displayed.

Did you forget the password?

The password may be disabled by entering a master password once. If you are authorized to make changes, enter the master password 508655 to unlock the controller.

ADVANCED OPERATION AND PROGRAMMING

In addition to the functions described in Controller Operation on page 34, the following advanced operation and display features may be programmed. Configuring these features may disable some default batch controller features, or make running a batch operation impossible. These functions should only be used by users who are sure of their need in their application.

Advanced Features Menu

To simplify the setup process, functions not needed for most applications are located in the *Advanced Features* menu.

Press and hold the Menu button for three seconds to access the advanced features of the controller. This cannot be done during a back process as all functions other than STOP are disabled during a batch process, including the Menu button.

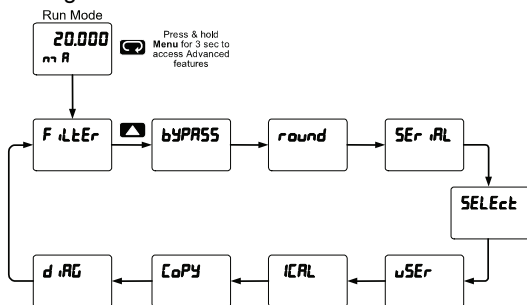

YPP6210 Advanced Features Menu

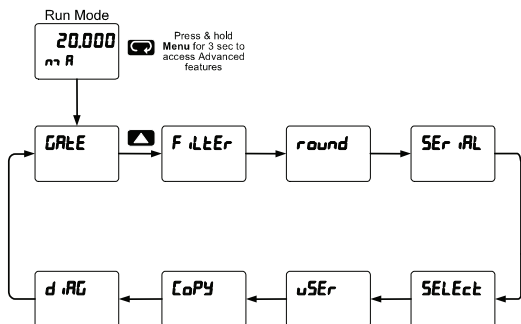

YPP6310 Advanced Features Menu

Advanced Features Menu & Display Messages

The following table shows the functions and messages of the *Advanced Features* menu in the order they appear in the menu.

Display	Parameter	Action/Setting
GATE	Gate	Gate settings (YPP6310)
Lo G	Low gate	Program Low gate value
Hi G	High gate	Program High gate value
FILTEr	Filter	Set noise filter value
Hi SPD	High Speed Filter	Program High Speed Filter
Lo SPD	Low Speed Filter	Program Low Speed Filter
bYPASS	Bypass	Set filter bypass value
round	Round	Set the rounding value for display variables
SERIAL	Serial	Set serial communication parameters
SLAVE ID	Slave ID	Set slave ID or controller address
baud	Baud rate	Select baud rate
tr dLY	Transmit delay	Set transmit delay for serial communication
PARITY	Parity	Select parity Even, Odd, or None with 1 or 2 stop bits
t-bytE	Time byte	Set byte-to-byte timeout
SELEct	Select	Enter the Select menu (function, cutoff, out)
FuncTIon	Signal Input Conditioning	Select linear, square root, or programmable exponent
LinEAR	Linear	Set controller for linear function and select number of linearization points
no Pts	Number of points	Set controller for 2 to 32-point linearization
SqUARE	Square root	Set controller for square root extraction
ProG R	Programmable exponent	Set controller for programmable exponent and enter exponent value
CuTtOFF	Cutoff	Set low-flow cutoff
Count	Count	Set the totals to count up or down from a set value
tot C	Total count	Set the batch to count up to or down from the preset

Model YPP6210 & YPP6310 Batch Controllers Instruction Manual

Display	Parameter	Action/Setting
uP	Up	Set the total to count up
doun	Down	Set the total to count down
Grand C	Grand total count	Set the grand total to count up or down from a defined value
C Start	Count start	Set the starting grand total value when counting down
Analog Pr	Analog output programming	Program analog output parameters
Source	Source	Select source for the 4-20 mA output
Overrange	Overrange	Program mA output for display overrange
Underrange	Underrange	Program mA output for display underrange
Loop Break	Loop Break	Set relay condition if loop break detected
Force output	Force output	Force analog output value for loop break
Ignore	Ignore	Ignore loop break condition
Max RH	Maximum	Program maximum mA output allowed
Min L	Minimum	Program minimum mA output allowed
Calibrate	Calibrate	Calibrate 4-20 mA output (internal reference source used for scaling the output)
4 mA R	4 mA output	Enter mA output value read by milliamp meter with at least 0.001 mA resolution
20 mA R	20 mA output	Enter mA output value read by milliamp meter with at least 0.001 mA resolution
User I/O	User I/O	Assign function keys and digital I/O
F 1	F1 function key	Assign F1 function key
F2	F2 function key	Assign F2 function key
F3	F3 function key	Assign F3 function key
F4	F4 function	Assign F4 function (digital input)
d 1 1	Digital input 1	Assign digital input 1 – 8, if expansion modules are connected
d 0 1	Digital output 1	Assign digital output 1 – 8, if expansion modules are connected
Internal Cal	Internal source calibration	Enter internal source calibration (used for scaling the controller without a signal source)
C Current Cal	Current calibration	Calibrating 4-20 mA current input (internal reference source used for scaling the input)

Model YPP6210 & YPP6310 Batch Controllers Instruction Manual

Display	Parameter	Action/Setting
<i>l Lo</i>	<i>Current low</i>	Calibrate low current input (e.g. 4 mA)
<i>l Hi</i>	<i>Current high</i>	Calibrate high current input (e.g. 20 mA)
<i>U CAL</i>	<i>Voltage calibration</i>	Calibrating voltage input
<i>U Lo</i>	<i>Voltage low</i>	Calibrate low voltage input (e.g. 0 V)
<i>U Hi</i>	<i>Voltage high</i>	Calibrate high voltage input (e.g. 10 V)
<i>CoPY</i>	<i>Copy</i>	Enter copy function
<i>SEnd</i>	<i>Send</i>	Send controller settings to another controller
<i>donE</i>	<i>Done</i>	Copy function completed
<i>d iAG</i>	<i>Diagnostics</i>	Display parameter settings
<i>inPUt</i>	<i>Input</i>	Input selection
<i>un itS</i>	<i>Units</i>	Select the display units/tags
<i>F iLtEr</i>	<i>Filter</i>	Set noise filter level
<i>bYPASS</i>	<i>Bypass</i>	Set filter bypass level
<i>r ound</i>	<i>Round</i>	Round the display values to the nearest entered multiple
<i>FunctiOn</i>	<i>Function</i>	Function selected
<i>SCALE</i>	<i>Scale</i>	Scaling parameter
<i>FRActor</i>	<i>K-factor</i>	K-factor value
<i>GRtE</i>	<i>Gate</i>	Gate settings
<i>CutOFF</i>	<i>Cutoff</i>	Cutoff value
<i>t tB</i>	<i>Total time base</i>	Set time period
<i>t CF</i>	<i>Total correction factor</i>	Set correction factor
<i>on odE</i>	<i>Batch mode</i>	Automatic or manual batch start
<i>t dELAY</i>	<i>Time delay</i>	Set time delay for automatic batch restart
<i>GRt tB</i>	<i>Grand total time base</i>	Set grand total time period
<i>GRt CF</i>	<i>GT correction factor</i>	Set grand total correction factor
<i>GRt rSE</i>	<i>Grand total reset</i>	Set grand total reset method
<i>dSPLY</i>	<i>Display</i>	Display assignments
<i>rELAY</i>	<i>Relays</i>	Relay settings
<i>Rout</i>	<i>Analog output</i>	Analog output scaling

Display	Parameter	Action/Setting
OutputPr	Analog output programming	Analog output programming
Serial	Serial	Set serial communication parameters
LED test	LED test	Test all LEDs
Info	Information	Display software information

Function Keys Operation

During operation, the programmable function keys operate according to the way they have been programmed in the *Advanced Features – User* menu. The following table shows the default setting for each of the function keys.

Function Key/Button	Default Setting	Action
F1/START	Start	Start batch
F2/BATCH	Presets	Change preset
F3/STOP	Stop	Pause/stop batch
F4/Digital Input	Start/Stop	Start/stop batch

F4 Operation

A digital input, F4, is standard on the meter. This digital input is programmed identically to function keys F1, F2, and F3. The input is triggered with a contact closure to COM, or with an active low signal. During operation, F4 operates according to the way it has been programmed in the *Advanced Features – User* menu.



Only STOP Operation Enabled if a Batch is Running.

During a batch process, the only function that can be performed is the pause/stop functions of the STOP button; the default programming of the F3 key. No other functions, including min/max display, manual alarm reset, or total reset, will function while a batch is running.

Advanced Setup and Calibration

Multi-Point Calibration & Scaling

The controller is set up at the factory for 2-point linear calibration. The number of points for multi-point calibration/scaling is set up in the *Advanced Features* menu. Up to 32 linearization points may be selected. See page 78 for details.

The controller can be programmed and operated using the PC-based PROPLUS software available for free download at www.yokogawa-usa.com.

Batches may be started, paused, and stopped, through the monitoring window of the PROPLUS software. Preset and preclose values may be changed, and the total and grand total reset.

Data logging for one controller at the time is available with PROPLUS software. More advanced data acquisition may be accomplished by using any Modbus RTU compliant software.

In order to operate or program the batch controller using a computer, the controller must be connected using a USB, RS-232, or RS-485 serial adapter, see Accessories on page 8 for details.

Maximum/Minimum Readings

The max & min readings (peak & valley) reached by the process can be displayed either continuously or momentary:

1. Display briefly by assigning to the digital inputs in the *User* menu.
2. Display continuously by assigning either display to max/min through the *Display* menu.



Changing the programming of the F1-F3 function keys will disable the default batch operation of these keys, and is not recommended for batch control applications.

Any of the digital inputs can be programmed to reset the max & min readings.

To display max/min readings continuously:

Assign either display to Max (d H i), Min (d L o), or toggle between Max and Min (d HL) every 10 seconds.

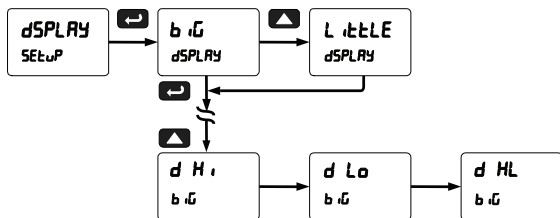

Note that changing default the programming of the upper or lower displays will interfere with seeing the batch total (upper display) or rate (lower display) of the batch process.

Noise Filter (FILTER)

The noise filter is available for unusually noisy signals that cause an unstable process variable display. The noise filter averages the input signal over a certain period. The filter level determines the length of time over which the signal is averaged. The filter level can be set between 2 and 199. The higher the filter level, the longer the averaging time and so the longer it takes the display to settle to its final value. Setting the filter level to zero disables the filter function.

Note: The filter for a YPP6310 works differently. There are two available settings: Hi Speed and Lo Speed (programmable from 2 to 50).

Noise Filter Bypass (BYPASS)

The noise filter bypass changes the behavior of the controller so that small variations in the signal are filtered out but large abrupt changes in the input signal are displayed immediately. The bypass value determines the minimum amount of signal change to be displayed immediately. All signal changes smaller than the bypass value are filtered or averaged by the controller. The noise filter bypass may be set between 0.1 and 99.9% of full scale.

Rounding Feature (round)

The rounding feature is used to give the user a steadier display with fluctuating signals. Rounding is used in addition to the filter function.

Rounding causes the display to round to the nearest value according to the rounding selected. This setting affects the last two digits, regardless of decimal point position.

Modbus RTU Serial Communications (SERIAL)

The controller is equipped with serial communications capability as a standard feature using Modbus RTU Serial Communication Protocol.

To communicate with a computer or other data terminal equipment, an RS-232, RS-485, or USB adapter option is required; see *Ordering Information* on page 7 for details.

**Warning!**

Do not connect any equipment other than Yokogawa's expansion modules, cables, or controllers to the RJ45 M-LINK connector. Otherwise damage will occur to the equipment and the controller.

Note: More detailed instructions are provided with each optional serial communications adapter. Note: Refer to the PROPLUS Modbus Register Tables located at www.yokogawa-usa.com for details.

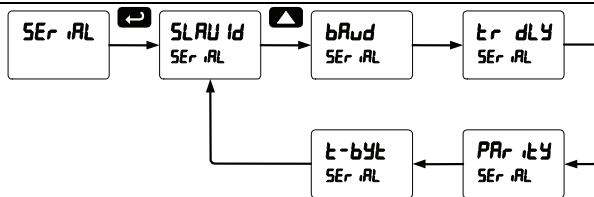

When using more than one controller in a multi-drop mode, each controller must be provided with its own unique address. The controller address (Slave ID) may be programmed between 1 and 247. The transmit delay may be set between 0 and 199 ms. The parity can be set to even, odd, or none with 1 or 2 stop bits.

The YPP6210 can also be connected to another YPP6210 with a special YPPA1200 cable, allowing the user to copy all the settings from one controller to another, using the *Copy* function.

A YPP6310 may be similarly connected to another YPP6310.

A YPP6210 may not be connected to a YPP6310.

Select Menu (SELEct)

The *Select* menu is used to select the signal input conditioning applied to the input (linear, square root, or programmable exponent, low-flow cutoff, and analog output programming. The multi-point linearization is part of the linear function selection.

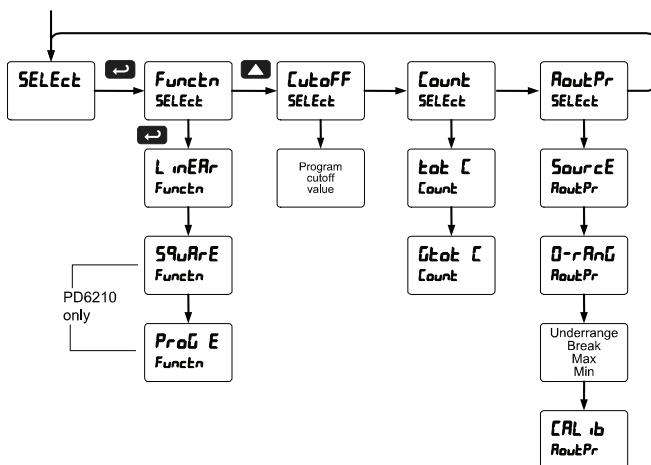

The *Function* menu is used to select the signal conditioning function applied to the input: linear, square root, or programmable exponent. The multi-point linearization is part of the linear function selection.

Controllers are set up at the factory for linear function with 2-point linearization. The linear function provides a display that is linear with respect to the input signal.

Square Root Linearization (*SqRtE*)

The square root function can be used to linearize the signal from a differential pressure transmitter and display flow rate in engineering units.

Programmable Exponent Linearization (*PrEx E*)

The programmable exponent can be used to linearize the signal from level transmitters in open-channel flow applications using weirs and flumes.

Multi-Point Linearization (*L inERr*)

Controllers are set up at the factory for linear function with 2-point linearization. Up to 32 linearization points can be selected under the linear function. The multi-point linearization can be used to linearize the display for non-linear signals such as those from level transmitters used to measure volume in odd-shaped tanks or to convert level to flow using weirs and flumes with complex exponent.

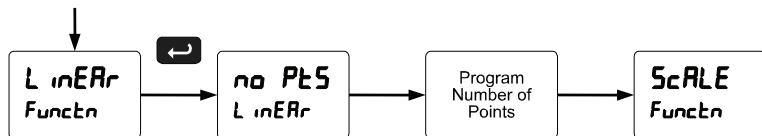

Low-Flow Cutoff (*Cutoff*)

The low-flow cutoff feature allows the controller to be programmed so that the often-unsteady output from a differential pressure transmitter, at low flow rates, always displays zero on the controller.

The cutoff value may be programmed from 0 to 999999. The controller will display zero below the cutoff value. Programming the cutoff value to zero disables the cutoff feature.

By default, the batch total and grand total count up during batch processes. Count parameter allows this to change. When set to count down, the batch total will count down from the preset to 0. When set to count down, the grand total will count down from a set value to zero.

Analog Output Programming (AnalogPr)

The *Analog Output Programming* menu is used to program the behavior of the 4-20 mA output. The following parameters and functions are programmed in this menu:

1. Source: Source for generating the 4-20 mA output (e.g. PV)
2. Overage: Analog output value with display in overrange condition
3. Underrange: Analog output value with display in underrange condition
4. Break: Analog output value when loop break is detected
5. Max: Maximum analog output value allowed regardless of input
6. Min: Minimum analog output value allowed regardless of input
7. Calibrate: Calibrate the internal 4-20 mA source reference used to scale the 4-20 mA output

Analog Output Source

The source for generating the 4-20 mA output may be assigned to the rate/process variable, total, grand total, maximum or minimum value reached by the rate/process, one of the set points, or the Modbus PV input.

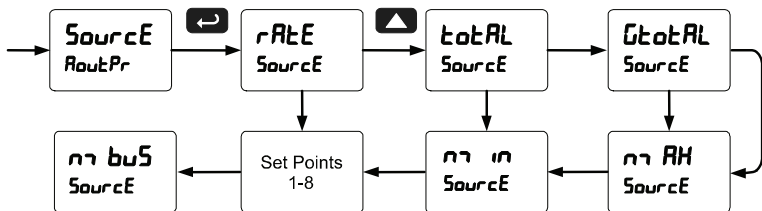

Analog Output Calibration

To perform the analog output calibration it's recommended to use a milliamp meter with a resolution of at least 0.1 μ A to measure the output current. The values saved internally during this procedure are used for scaling the 4-20 mA output in the *Setup* menu.

Programmable Function Keys User Menu (µ5Er)

Changing the programming of the F1-F3 function keys will disable the default batch operation of these keys, and is not recommended for batch control applications.

The *User* menu allows the user to assign the front panel function keys F1, F2, F3, F4 (digital input) and up to eight digital inputs (DI 1 to DI 8) to access most of the menus or to activate functions immediately (e.g. Reset max & min). Up to eight digital outputs (DO 1 to DO 8) can be assigned to a number of actions and functions executed by the controller (e.g. Alarms, relay acknowledgement, etc.).

Function Keys & Digital I/O Available Settings

Display	Description	Display	Description
StArt	Start batch	rESEt	Reset Menu
StoP	Pause/stop batch	rSt t	Reset total
StStP	Start/stop combo	rSt Gt	Reset grand total
rLY d	Disable all relays	rSt bc	Reset batch count
rLY E	Enable all relays	rSt H i	Reset max
o Hold	Output level hold	rSt Lo	Reset min
d Hold	Display hold	rSt HL	Reset max & min
b iu H i	Max on Upper display	rELRY	Relay menu
b iu Lo	Min on Upper display	PrESEt	Change preset
b iu HL	Max/min on Upper display	SEt 2	Set point 2 – 8
l iL H i	Max on Lower display	n ENu	Enter menu (DI only)
l iL Lo	Min on Lower display	r iuhL	Right/F1(DI only)
l iL HL	Max/min Lower display	uP	Up/F2 (DI only)
l iL Gt	GT on Lower display	EntEr	Enter/F3 (DI only)
l iL bc	Batch count display	F On 1	Force relay 1 on (DI only)
ContrL	Control Menu	F On 2	Force relay 2 on (DI only)
d iAbL	Disable input/button	F On 3	Force relay 3 on (DI only)
RcH	Acknowledge relays	F On 4	Force relay 4 on (DI only)

YPP6210 Only: Internal Source Calibration (μRL)

Note: The YPP6210 is factory calibrated prior to shipment to read in milliamps and volts depending on the input selection. The calibration equipment is certified to NIST standards.

The use of a calibrated signal source is necessary to calibrate the internal source of the meter. The meter's internal source is what allows the user to scale the meter without applying a signal.

Check calibration of the controller at least every 12 months. Each input type must be recalibrated separately.

Notes:

- 1. If controller is in operation and it is intended to accept only one input type (e.g. 4-20 mA), recalibration of other input is not necessary.*
- 2. Allow the controller to warm up for at least 15 minutes before performing the internal source calibration procedure.*

The *Internal calibration* menu is part of the *Advanced Features* menu.

1. Press and hold the Menu button for three seconds to access the advanced features of the controller.
2. Press the Up arrow button to scroll to the *Internal calibration* menu (μRL) and press Enter.
3. The controller displays either current calibration (μRL) or voltage calibration ($V RL$), according to the input setup. Press Enter to start the calibration process.

Example of Internal Calibration for current input:

4. The controller displays *low* input current message ($\mu L \alpha$). Apply the low input signal and press Enter. The display flashes for a moment while the controller is accepting the low input signal.
5. After the display stops flashing, a number is displayed with the leftmost digit brighter than the rest. The bright digit is the active digit that can be changed by pressing the Up arrow button. Press the Right arrow button to move to the next digit.
6. Set the display value to correspond to the input signal being calibrated, typically 4.000 mA.
7. The display moves to the *high* input calibration ($\mu H \alpha$). Apply the high input signal and press Enter.
8. Set the display for the high input calibration, in the same way as it was set for the low input calibration, typically 20.000 mA.

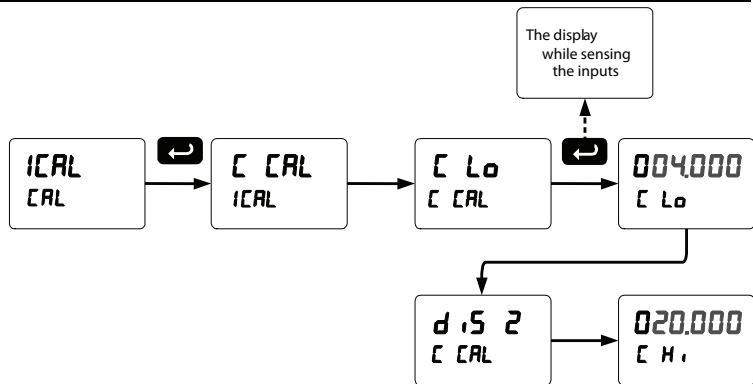

The graphic above shows the calibration of the current input. The voltage input is calibrated in a similar way.

Tips:

- Low and high input signals can be any valid value within the range of the controller.
- Observe minimum input span requirements between input 1 and input 2.
- Low input should be less than high input signal.

Error Message (*Error*)

An error message indicates that the calibration or scaling process was not successful.

After the error message is displayed, the controller reverts to input 2 during calibration or scaling and to input 1 during internal calibration, allowing the appropriate input signal to be applied or programmed.

The error message might be caused by any of the following conditions:

1. Input signal is not connected to the proper terminals, or it is connected backwards.
2. Wrong signal selection in *Setup* menu.
3. Minimum input span requirements not maintained.

Minimum Input Span

The minimum input span is the minimum difference between input 1 and 2 signals required to complete the calibration or scaling of the controller.

Input range	Input 1 & input 2 span
4-20 mA	0.15 mA
±10 VDC	0.10 VDC

Controller Copy Function (Copy)

The Copy function is used to copy (or clone) all the settings from one controller to other controllers requiring exactly the same setup and programming (i.e. type of input, scaling, decimal point, filter, bypass, etc.).



Warning!

Only the YPPA1200 meter copy cable must be used for meter-to-meter interfacing. Using standard CAT5 or other cable will cause damage to both controllers.

Copy Function Requirements

To successfully copy settings from one controller to another, both controllers must have the same software version and baud rate setting. See Determining Software Version, page 84 for instructions.

Controller Copy or Cloning Instructions



Caution!

Do not connect the two controllers to the same signal source while cloning. Internal calibration may be affected.

1. Connect two controllers using a YPPA1200 controller copy cable.
2. Do not connect the two controllers to the same signal source.
3. Power up both controllers. Leave clone controller in Run Mode.
4. Enter the *Advanced Features* menu of the Master controller see **ADVANCED OPERATION AND PROGRAMMING** page 70.
5. Scroll to the Copy function using the Up arrow button then press Enter.
6. The controller displays the message *Send*. Press Enter, the display flashes while sending data. The message *done* is displayed when copying is completed.

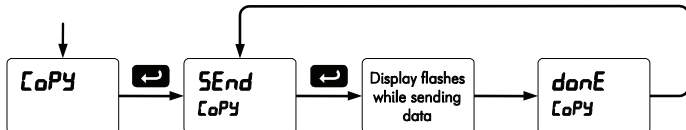

7. The Clone controller displays the message `[PY r]` while being programmed then the message `donE` when copying is completed. The controller initializes and returns to Run Mode using the same settings as the Master.
8. If controller to be cloned does not respond to the data being sent, refer to the **Copy Function Requirements** on page 83.

TROUBLESHOOTING

The rugged design and the user-friendly interface of the controller should make it unusual for the installer or operator to refer to this section of the manual. However, due to the many features and functions of the controller, it's possible that the setup of the controller does not agree with what an operator expects to see.

If the controller is not working as expected, refer to the *Diagnostics* menu and recommendations below.

Diagnostics Menu (`d rG`)

The *Diagnostics* menu is located in the *Advanced Features* menu, to access *Diagnostics* menu see **ADVANCED OPERATION AND PROGRAMMING**, page 70.

It provides an easy way to view the programmed parameter settings for troubleshooting purposes. Press the Enter button to view the settings and the Menu button to exit at any time.

For a description of the diagnostic messages, see *Advanced Features Menu & Display Messages*, page 71.

Determining Software Version

To determine the software version of a controller:

1. Go to the *Diagnostics* menu (`d rG`) and press Enter button.
2. Press Up arrow button and scroll to Information menu (`InfD`).
3. Press Enter to access the software number (`SEt`) and version (`VER`) information. Write down the information as it is displayed. Continue pressing Enter until all the information is displayed.
4. The controller returns to Run Mode after displaying all the settings.

Reset Controller to Factory Defaults

When the parameters have been changed in a way that is difficult to determine what's happening, it might be better to start the setup process from the factory defaults.

Instructions to load factory defaults:

1. Enter the *Advanced Features* menu. See ADVANCED OPERATION AND PROGRAMMING, page 70.
2. Press Up arrow to go to *Diagnostics* menu
3. Press and hold Right arrow for three seconds, press Enter when display flashes *rESEt*.
Note: If Enter is not pressed within three seconds, the display returns to the *Diagnostics* menu.
4. The controller goes through an initialization sequence (similar as on power-up), and loads the factory default settings.

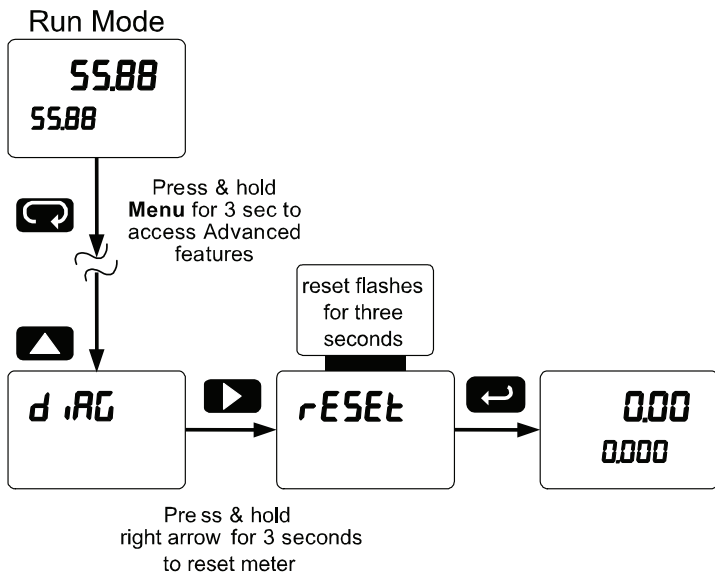

Factory Defaults & User Settings

The following table shows the factory setting for the major programmable parameters on the controller. Next to the factory setting, the user may record the new setting for the particular application.

Model: _____ S/N: _____ Date: _____

Parameter	Display	Default Setting	User Setting
Input type	<i>inPut</i>	YPP6210: 4-20 mA YPP6310: Pulse	
Total	<i>YES</i>	Total enabled	
Units (YPP6210)	<i>units</i>	Rate / total / gr. total mA / mA / mA	
Units (YPP6310)	<i>units</i>	Rate / total / gr. total Pulse / Pulse / Pulse	
Rate decimal point	<i>dddddd</i>	YPP6210: 3 Places YPP6310: 1 Place	
Total decimal point	<i>dddddd</i>	1 Place	
G. Total decimal point	<i>dddddd</i>	0 Places	
K-factor	<i>FActoR</i>	1.000; YPP6310 Only	
Function	<i>FunctiOn</i>	Linear	
Number of points	<i>no Pts</i>	2	
Programming	<i>Prog</i>	Scale	
Input 1	<i>inP 1</i>	YPP6210: 4.000 mA YPP6310: 00000.0	
Display 1	<i>d 1 i</i>	YPP6210: 4.000 YPP6310: 00000.0	
Input 2	<i>inP 2</i>	YPP6210: 20.000mA YPP6310: 10000.0	
Display 2	<i>d 1 2</i>	YPP6210: 20.000 YPP6310: 10000.0	
Upper display	<i>b 1</i>	Display total	
Lower display	<i>L 1LE</i>	Display rate and units	
Display intensity	<i>d- intY</i>	8	
Total time base	<i>t tB</i>	Second	

Model YPP6210 & YPP6310 Batch Controllers Instruction Manual

Parameter	Display	Default Setting	User Setting
Total conversion factor	፩ ርፑ	1.000	
Batch mode	ጠጠ ሰፊ፫	Manual	
Grand total time base	፬፫፫ ፩፭	Second	
Grand total conversion factor	፩ ርፑ	1.000	
Grand total reset	፩ ጠፍ፫	Manual	
Relay 1 assignment	ጸፍ ሰጠ 1	Total	
Relay 2 assignment	ጸፍ ሰጠ 2	Total	
Relay 2 preclose	ፑጠ፫፫፫፫	No	
Relay 3 assignment	ጸፍ ሰጠ 3	Rate	
Relay 4 assignment	ጸፍ ሰጠ 4	Rate	
Relay 1 action	ጸ፫፫ 1	Automatic	
Batch preset	ፑጠ፫፫፫፫	100.0	
Relay 2 action	ጸ፫፫ 2	Automatic	
Relay 2 set point	፫፫፫ 2	200.0	
Relay 3 action	ጸ፫፫ 3	Automatic	
Relay 3 set point	፫፫፫ 3	3.000	
Relay 3 reset point	ጠፍ፫ 3	2.500	
Relay 4 action	ጸ፫፫ 4	Automatic	
Relay 4 set point	፫፫፫ 4	4.000	
Relay 4 reset point	ጠፍ፫ 4	3.500	
Fail-safe relay 1	ፑ፫፫ 1	Off	
Fail-safe relay 2	ፑ፫፫ 2	Off	
Fail-safe relay 3	ፑ፫፫ 3	Off	

Model YPP6210 & YPP6310 Batch Controllers Instruction Manual

Parameter	Display	Default Setting	User Setting
Fail-safe relay 4	<i>FLS 4</i>	Off	
On delay relay 1	<i>On 1</i>	0.0 sec	
Off delay relay 1	<i>OFF 1</i>	0.0 sec	
On delay relay 2	<i>On 2</i>	0.0 sec	
Off delay relay 2	<i>OFF 2</i>	0.0 sec	
On delay relay 3	<i>On 3</i>	0.0 sec	
Off delay relay 3	<i>OFF 3</i>	0.0 sec	
On delay relay 4	<i>On 4</i>	0.0 sec	
Off delay relay 4	<i>OFF 4</i>	0.0 sec	
Loop break relay 1	<i>Ignore</i>	Ignore, YPP6210 Only	
Loop break relay 2	<i>Ignore</i>	Ignore, YPP6210 Only	
Loop break relay 3	<i>Ignore</i>	Ignore, YPP6210 Only	
Loop break relay 4	<i>Ignore</i>	Ignore, YPP6210 Only	
Display 1 analog out	<i>d 15 1</i>	YPP6210: 4.000 YPP6310: 0	
Output 1 value	<i>Out 1</i>	4.000 mA	
Display 2 analog out	<i>d 15 2</i>	YPP6210: 20.000 YPP6310: 1000.0	
Output 2 value	<i>Out 2</i>	20.000 mA	
Source analog output	<i>Source</i>	Rate/process	
Overrange output	<i>OverRnG</i>	21.000 mA	
Underrange output	<i>u-rRnG</i>	3.000 mA	
Loop break output	<i>brERH</i>	1.000 mA	
Filter	<i>F iLEr</i>	YPP6210: 70 YPP6310: Hi Spd	
Bypass	<i>bYPASS</i>	0.2, YPP6210 Only	

Model YPP6210 & YPP6310 Batch Controllers Instruction Manual

Parameter	Display	Default Setting	User Setting
Cutoff value	ƒuƒoFF	0.000 (disabled)	
Maximum output	ḡ Ḡ RH	23.000 mA	
Minimum output	ḡ ḡ ḡ	1.000 mA	
Slave ID (Address)	SLAVE id	247	
Baud rate	bRud	9600	
Transmit delay	ƒr dLY	50 ms	
Parity	PRr ƒY	Even	
Byte-to-byte timeout	ƒ-bYƒ	010 (0.1 sec)	
F1 function key	F 1	Start	
F2 function key	F 2	Preset	
F3 function key	F 3	Stop	
F4 function	F 4	Start/Stop	
Digital input 1	d 1 1	Menu	
Digital input 2	d 1 2	Right arrow	
Digital input 3	d 1 3	Up arrow	
Digital input 4	d 1 4	Enter	
Digital output 1-4	d0 1	Alarm 1-4	
Password 1	PRSS 1	000000 (unlocked)	
Password 2	PRSS 2	000000 (unlocked)	
Password 3	PRSS 3	000000 (unlocked)	
Total password	ƒoƒRL	000000 (unlocked)	
Grand total password	ƒƒoƒRL	000000 (unlocked)	

Troubleshooting Tips

Symptom	Check/Action
No display at all	Check power at power connector
Not able to change setup or programming, <i>Lacd</i> is displayed	Controller is password-protected, enter correct six-digit password to unlock
Controller displays error message during calibration (<i>Error</i>)	Check: <ol style="list-style-type: none"> Signal connections Input selected in <i>Setup</i> menu Minimum input span requirements
Controller displays 999999 -999999	Check: <ol style="list-style-type: none"> Input selected in <i>Setup</i> menu Corresponding signal at Signal connector
Display is unstable	Check: <ol style="list-style-type: none"> Input signal stability and value Display scaling vs. input signal Filter and bypass values (increase)
Display response is too slow	Check filter and bypass values
Display reading is not accurate	<ol style="list-style-type: none"> Signal input conditioning selected: Linear, square root, etc. Scaling or calibration
Display does not respond to input changes, reading a fixed number	Check: Display assignment, it might be displaying max, min, or set point.
Display alternates between <ol style="list-style-type: none"> <i>H i</i> and a number <i>L o</i> and a number 	Press Menu to exit max/min display readings.
Relay operation is reversed	Check: <ol style="list-style-type: none"> Fail-safe in <i>Setup</i> menu Wiring of relay contacts
Relay and status LED do not respond to signal	Check: <ol style="list-style-type: none"> Relay action in <i>Setup</i> menu Set and reset points
Flashing relay status LEDs	Relays in manual control mode or relay interlock switches opened.
Controller not communicating with application programs	Check: <ol style="list-style-type: none"> Serial adapter and cable Serial settings Controller address and baud rate
If the display locks up or the controller does not respond at all	Cycle the power to reboot the microprocessor.
Other symptoms not described above	Call Technical Support for assistance.

Note: Certain sequences of events can cause unexpected results. To solve these issues, it is best to start fresh from factory defaults and map changes ahead of time, rather than at random.

Alphabetical List of Display Functions & Messages

Display	Parameter	Action/Setting Description
20 mA R	20 mA output	Enter mA output value read by milliamp meter with at least 0.001 mA resolution
4 mA R	4 mA output	Enter mA output value read by milliamp meter with at least 0.001 mA resolution
999999 -999999	Flashing display	Overrange condition Underrange condition
RcH	Acknowledge	Acknowledge relays
Rct 1	Action 1	Set relay 1 action
RLn 1	Alarm 1	Assign digital output to Alarm 1 – 8
RLErR	Alternate	Set relay for pump alternation control (relays assigned to rate)
R-rRr	Auto-manual	Set relay for automatic & manual reset any time
Rout	Analog output	Analog output scaling
RoutPr	Analog output programming	Analog output programming
R5 n 1	Assign 1	Relay 1 assignment
R55 n	Assignment	Assign relays to rate, total, or grand total
Ruto	Automatic	For automatic reset
bRud	Baud rate	Select baud rate
b n	Upper display	Press Enter to assign the Upper display parameter (default: PV or rate)
b n H 1	Max on Upper display	Assign digital input to display max on the Upper display
b n HL	Max/min Upper display	Assign digital input to toggle max/min on the Upper display
b n Lo	Min on Upper display	Assign the digital input to display min on the Upper display
brERH	Loop break	Set relay condition if loop break detected (For mA input only)
bYPASS	Bypass	Set filter bypass value

Model YPP6210 & YPP6310 Batch Controllers Instruction Manual

Display	Parameter	Action/Setting Description
[<i>RL</i>]	<i>Current calibration</i>	Calibrating 4-20 mA current input (internal reference source used for scaling the input)
[<i>H i</i>]	<i>Current high</i>	Calibrate high current input (e.g. 20 mA)
[<i>Lo</i>]	<i>Current low</i>	Calibrate low current input (e.g. 4 mA)
[<i>RL</i>]	<i>Calibrate</i>	Enter the <i>Calibrate</i> menu
[<i>RL</i> <i>ib</i>]	<i>Calibrate</i>	Calibrate 4-20 mA output (internal reference source used for scaling the output)
[<i>ontrol</i>]	<i>Control</i>	Enter <i>Control</i> menu
[<i>OPY</i>]	<i>Copy</i>	Enter copy function
[<i>ount</i>]	<i>Count</i>	Set total and grand total count direction
[<i>utoff</i>]	<i>Cutoff</i>	Cutoff value
<i>d H i</i>	<i>Display high</i>	Select to display the max
<i>d HL</i>	<i>Display H&L</i>	Select to display the max & min toggling
<i>d Hold</i>	<i>Display hold</i>	Display hold
<i>d Lo</i>	<i>Display low</i>	Select to display the min
<i>d off</i>	<i>Display off</i>	Select to not turn off display
<i>d rRtE</i>	<i>Display rate</i>	Select to display rate
<i>d tot</i>	<i>Display total</i>	Select to display batch total
<i>d Totot</i>	<i>Display grand total</i>	Select to display grand total
<i>d G-t</i>	<i>Display g-t</i>	Select to display grand total and batch total
<i>d r-t</i>	<i>Display r-t</i>	Select to display rate and batch total
<i>d r-u</i>	<i>Display r-u</i>	Select to display rate and units
<i>d units</i>	<i>Display units</i>	Select to display engineering units or label
<i>dCount</i>	<i>Display Count</i>	Select to display number of batches
<i>dEc Pt</i>	<i>Decimal point</i>	Set decimal point for rate, total, grand total
<i>dELAY</i>	<i>Delay</i>	Enter relay <i>Time Delay</i> menu

Model YPP6210 & YPP6310 Batch Controllers Instruction Manual

Display	Parameter	Action/Setting Description
d 1 1	Digital input 1	Assign digital input 1-8, if expansion modules are connected
d iRC	Diagnostics	Display parameter settings
d- iNtY	Display intensity	Set display intensity level from 1 to 8
d iS 1	Display 1	Program display 1 value
d iS 2	Display 2	Program display 2 value
d iSRbL	Disable	Disable function key
dLY 1	Delay 1	Enter relay 1 time delay setup
dO 1	Digital output 1	Assign digital output 1 – 8, if expansion modules are connected
donE	Done	Copy function completed
dounn	Down	Set the total to count down
dSEt 1	Display set 1	Select to display set point 1 (1-8)
dSPLRy	Display	Enter the <i>Display</i> menu
EnTEr	Enter Button	Assign digital input to Enter button
Error	Error	Error, calibration not successful, check signal or programmed value
F On 1	Force On 1	Force relay 1 on using digital input (1-8)
F 1	F1 function key	Assign F1 function key
F2	F2 function key	Assign F2 function key
F3	F3 function key	Assign F3 function key
F4	F4 function	Assign F4 function (digital input)
FRcEor	K-factor Scaling	Programs unit to convert input pulse to rate in engineering units
FR iLSF	Fail-safe	Enter <i>Fail-safe</i> menu
F iLEEr	Filter	Set noise filter value
FLS 1	Fail-safe 1	Set relay 1 fail-safe operation
ForcE	Force	Force analog output value for loop break

Model YPP6210 & YPP6310 Batch Controllers Instruction Manual

Display	Parameter	Action/Setting Description
<i>FunctiOn</i>	<i>Function</i>	Select linear, square root, or programmable exponent signal input conditioning
<i>Grand total</i>	<i>Grand total</i>	Assign relay to grand total
<i>Grand total conversion factor</i>	<i>Grand total conversion factor</i>	Program grand total conversion factor
<i>Grand total reset</i>	<i>Grand total reset</i>	Program grand total reset mode: auto or manual
<i>Grand total time base</i>	<i>Grand total time base</i>	Program grand total time base
<i>Grand Total Count</i>	<i>Grand Total Count</i>	Set grand total to count up or down
<i>Grand total password</i>	<i>Grand total password</i>	Set or enter password for manual reset
<i>High Speed Filter</i>	<i>High Speed Filter</i>	Program High Speed Filter
<i>Internal source calibration</i>	<i>Internal source calibration</i>	Enter internal source calibration (used for scaling the controller without a signal source)
<i>Ignore</i>	<i>Ignore</i>	Ignore loop break condition
<i>Input Calibration</i>	<i>Input Calibration</i>	Enter the <i>Input Calibration</i> menu
<i>Information</i>	<i>Information</i>	Display software and S/N information
<i>Input 1</i>	<i>Input 1</i>	Calibrate input 1 signal or program input 1 value
<i>Input 2</i>	<i>Input 2</i>	Calibrate input 2 signal or program input 2 value (up to 32 points)
<i>Input selection</i>	<i>Input</i>	Input selection
<i>Latching</i>	<i>Latching</i>	Set relay for latching operation (relays assigned to rate)
<i>LED test</i>	<i>LED test</i>	Test all LEDs
<i>Linear</i>	<i>Linear</i>	Set controller for linear function and select number of linearization points
<i>Max on Lower display</i>	<i>Max on Lower display</i>	Assign digital input to display max on the Lower display
<i>Max/min Lower display</i>	<i>Max/min Lower display</i>	Assign the digital input to toggle max/min on the Lower display

Model YPP6210 & YPP6310 Batch Controllers Instruction Manual

Display	Parameter	Action/Setting Description
L ı Ł	<i>Min on Lower display</i>	Assign digital input to display min on the Lower display
L ı ŁŁE	<i>Lower display</i>	To assign the Lower display parameters
Łocđ	<i>Locked</i>	Enter password to unlock controller
Ł 5Pd	<i>Low Speed Filter</i>	Program Low Speed Filter
ŁŁ - ŁŁr	<i>Latching-cleared</i>	Set relay for latching operation with manual reset only after alarm condition has cleared (relays assigned to rate)
ı R	<i>4-20 mA</i>	Set controller for 4-20 mA input
ı Rı	<i>Manual</i>	To manually control
ı RH	<i>Maximum</i>	Program maximum mA output allowed
ı ıŁ	<i>Modbus</i>	Select to display Modbus input or to assign Modbus input as the analog output source
ı Eı	<i>Menu button</i>	Assign digital input to Menu button
ı ı	<i>Minimum</i>	Program minimum mA output allowed
ı PŁ	<i>Number of points</i>	Set controller for 2 to 32-point linearization
ıııŁ	<i>Non-resettable</i>	Non-resettable grand total set after entering "050873" for Gtotal password
ı HŁđ	<i>Relays output hold</i>	Assign digital input to hold all relays state hold
ıFF	<i>Off</i>	Disable relay and front panel status LED, turn relays off, program off time delay
ıFF ı	<i>Off</i>	Set relay 1 Off time delay
ıı	<i>On</i>	Enable fail-safe operation, turn relays on, program on time delay
ıı ı	<i>On</i>	Set relay 1 On time delay
ııı Rı	<i>Overrange</i>	Program mA output for display overrange
ııŁ ı	<i>Output 1</i>	Program output 1 value (e.g. 4.000 mA)
ııŁ 2	<i>Output 2</i>	Program output 2 value (e.g. 20.000 mA)
ıPŁŁ	<i>Password</i>	Enter the <i>Password</i> menu
ıPŁŁ ı	<i>Password 1</i>	Set or enter Password 1

Model YPP6210 & YPP6310 Batch Controllers Instruction Manual

Display	Parameter	Action/Setting Description
PRSS 2	Password 2	Set or enter Password 2
PRSS 3	Password 3	Set or enter Password 3
PrECL5	Preclose	The amount before the preset is reached that multi-stage relays will deactivate.
PrESEt	Preset	Batch control preset
PrOG	Program	Enter the <i>Program</i> menu
PrOG E	Programmable exponent	Set controller for programmable exponent and enter exponent value
rRtE	Rate	Assign relay to rate
rELAY	Relay	Enter the <i>Relay</i> menu
rESEt	Reset	To access the <i>Reset</i> menu
r →ht	Right arrow	Assign digital input to Right arrow button/F1
rLY 1	Relay 1	Relay 1 setup
rLY 2	Relay 2	Relays 2-8 setup <i>Note: Relays 5-8 are shown, only if expansion relay module is installed.</i>
rLY d	Disable relay	Assign digital input to disable all relays
rLY E	Enable relay	Assign digital input to enable all relays
rOund	Round	Select rounding values for PV display
rSt 1	Reset 1	Program reset point 1
rSt bc	Reset batch count	To reset the batch count
rSt Gt	Reset grand total	To reset grand total
rSt H i	Reset high	Press Enter to reset max display
rSt HL	Reset high & low	Press Enter to reset max & min displays
rSt Lo	Reset low	Press Enter to reset min display
rSt t	Reset Total	Reset total
SRnPL	Sampling	Set relay for sampling operation

Model YPP6210 & YPP6310 Batch Controllers Instruction Manual

Display	Parameter	Action/Setting Description
<i>SCALE</i>	<i>Scale</i>	Enter the <i>Scale</i> menu
<i>SElect</i>	<i>Select</i>	Enter the Select menu (function, cutoff, out)
<i>SEnd</i>	<i>Send</i>	Send controller settings to another controller
<i>SErIAL</i>	<i>Serial</i>	Set serial communication parameters
<i>SEt 1</i>	<i>Set 1</i>	Program set point 1
<i>SEtUP</i>	<i>Setup</i>	Enter <i>Setup</i> menu
<i>SLAVE id</i>	<i>Slave ID</i>	Set Slave ID or controller address
<i>SOURCE</i>	<i>Source</i>	Select source for the 4-20 mA output
<i>SQUARE</i>	<i>Square root</i>	Set controller for square root extraction
<i>Start</i>	<i>Start</i>	Begin batch
<i>Stop</i>	<i>Stop</i>	Pause/Stop batch
<i>reset</i>	<i>Reset tare</i>	Reset tare
<i>capture</i>	<i>Capture Tare</i>	Capture Tare
<i>TCF</i>	<i>Total conversion factor</i>	Program total conversion factor
<i>tdly</i>	<i>Time delay</i>	Program time delay for total auto reset
<i>trst</i>	<i>Total reset</i>	Program total reset mode: auto or manual
<i>ttb</i>	<i>Total time base</i>	Program total time base
<i>totc</i>	<i>Total Count</i>	Set total to count up or down
<i>total</i>	<i>Total</i>	Enable or disable totalizer features
<i>trdly</i>	<i>Transmit delay</i>	Set transmit delay for serial communication
<i>units</i>	<i>Units</i>	Select the display units/tags
<i>unlock</i>	<i>Unlocked</i>	Program password to lock controller
<i>up</i>	<i>Up arrow button</i>	To assign digital input to up arrow button
<i>up</i>	<i>Up</i>	Set the total to count up
<i>underrange</i>	<i>Underrange</i>	Program mA output for display underrange
<i>user</i>	<i>User I/O</i>	Assign function keys and digital I/O

Model YPP6210 & YPP6310 Batch Controllers Instruction Manual

Display	Parameter	Action/Setting Description
<i>U [RL</i>	<i>Voltage calibration</i>	Calibrating voltage input
<i>U H i</i>	<i>Voltage high</i>	Calibrate high voltage input (e.g. 10 V)
<i>U L o</i>	<i>Voltage low</i>	Calibrate low voltage input (e.g. 0 V)
<i>UoL t</i>	<i>0-10 VDC</i>	Set controller for ± 10 VDC input

How to Contact Yokogawa Corporation of America

- For Sales and Technical Support please
Call: (800) 888-6400 or (770) 254-0400
Fax: (770) 251-2088
Email: meters-instr@us.yokogawa.com
- For the latest version of this manual please visit
www.yokogawa-usa.com