

Deluxe Mobile Reversible Boards

Model No: 668XX-XX

OVERVIEW

Boards are double sided, available in a variety of surface combinations, and rotate 360° on a pivot hinge.

SURFACES

Surfaces available for mobile reversible boards are tackable natural cork, Dura-Rite HPL dry-erase markerboard, and porcelain steel magnetic dry erase markerboard. The double sided porcelain steel option utilizes 28 Ga porcelain steel markerboard on both sides of a 7/16" MDF panel. Double sided Dura-Rite HPL option utilizes 0.04" thick Dura-Rite HPL on both sides of a 7/16" Hexacomb panel. Double-sided natural cork option uses two 1/16" natural cork panels on either side of 3/8" fiberboard. With a Dura-Rite or porcelain steel surface on one side and natural cork on the other, a four layer board is used, made up of 1/4" natural cork, 28 Ga galvanized steel, 1/4" MDF, and either 28 Ga porcelain steel or 0.04" thick Dura-Rite HPL. Surfaces are available with 0.60" thick aluminum trim in four sizes, 40"H x 30"W, 4'H x 5'W, 4'H x 6'W, or 4'H x 8'W.

FRAME

The frame is made of two 0.07" thick aluminum legs, a full length 0.075" thick aluminum tray, and a 0.05" thick 1" diameter aluminum tube cross brace. The legs are made of two 2.75" x 0.56" sections. The horizontal is 24.25" long and is connected to the 53.75" long vertical section with three M5 x 6mm screws on each side. Plastic endcaps cover all open ends of the frame legs. The aluminum tray is a 2.5" by 3" 'T' that has 0.36" diameter caps on each edge. Six M4 x 25mm screws attach the tray to the legs through these caps. The cross brace is held to the legs with two M6 x 35mm screws. One 10 Ga 3.35" x 1.725" steel flange with an M8 x 35mm bolt is attached to each side of the markerboard trim with two M5 x 15mm screws. At the top of the legs are two 10 Ga steel plates 3.35" x 1.725" that support the flange bolts. The flange bolts attach on the outside of the legs to a 2.2" diameter x 1.0" deep plastic knob on each side to lock the markerboard in place. The frame is attached to four 3" casters with M10 x 15mm stems.



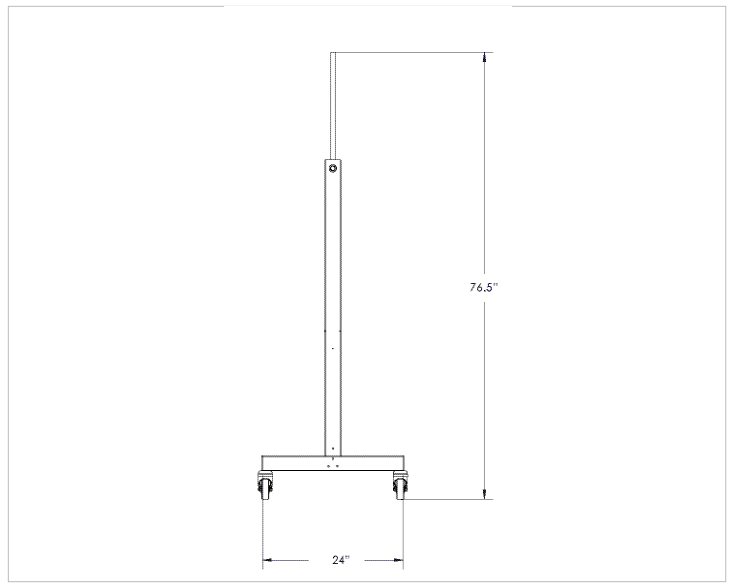
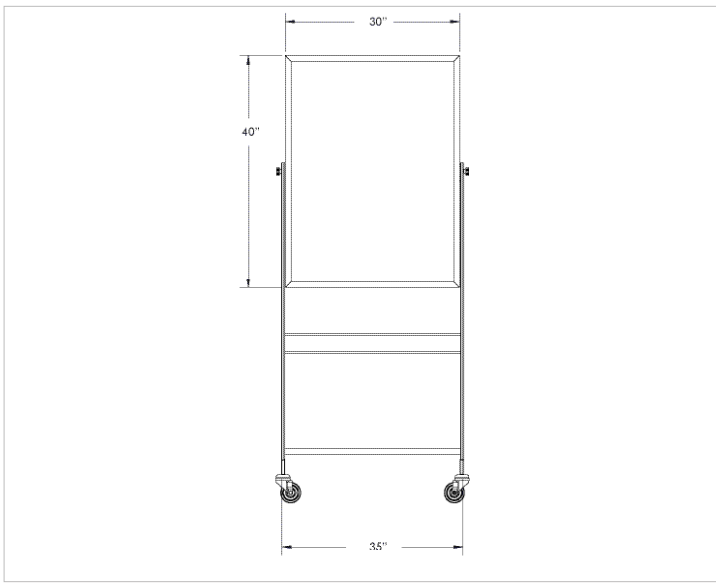
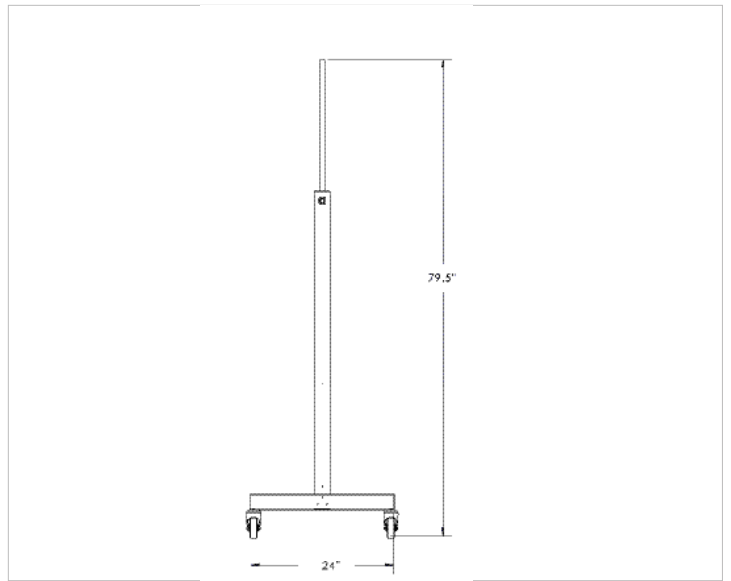
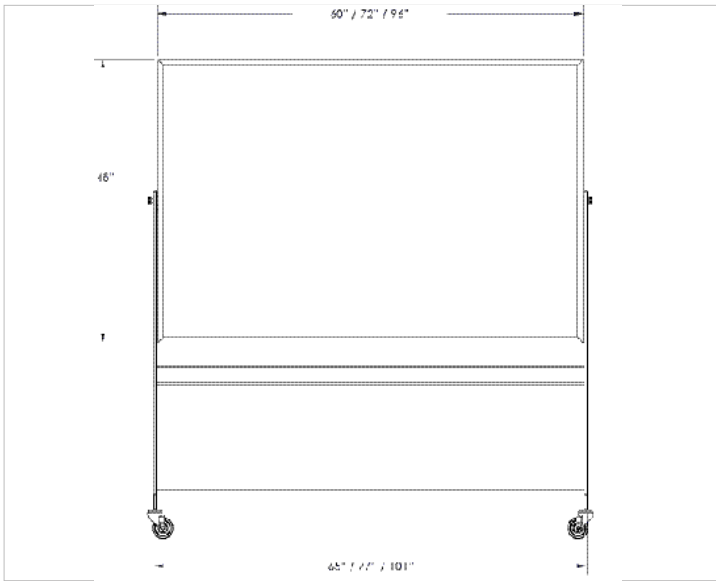

DIMENSIONS:

Base Model No.	Description	Surface Dimensions	Overall Dimensions
668AC-DD	Porcelain Steel / Porcelain Steel - Aluminum Trim	40"H X 30"W	76.5"H X 35"W X 24"D
668AC-DC	Porcelain Steel / Natural Cork - Aluminum Trim	40"H X 30"W	76.5"H X 35"W X 24"D
668AC-HH	Dura-Rite / Dura-Rite - Aluminum Trim	40"H X 30"W	76.5"H X 35"W X 24"D
668AC-HC	Dura-Rite / Natural Cork - Aluminum Trim	40"H X 30"W	76.5"H X 35"W X 24"D
668AC-CC	Natural Cork / Natural Cork - Aluminum Trim	40"H X 30"W	76.5"H X 35"W X 24"D
668AF-DD	Porcelain Steel / Porcelain Steel - Aluminum Trim	4"H X 5"W	79.5"H X 65"W X 24"D
668AF-DC	Porcelain Steel / Natural Cork - Aluminum Trim	4"H X 5"W	79.5"H X 65"W X 24"D
668AF-HH	Dura-Rite / Dura-Rite - Aluminum Trim	4"H X 5"W	79.5"H X 65"W X 24"D
668AF-HC	Dura-Rite / Natural Cork - Aluminum Trim	4"H X 5"W	79.5"H X 65"W X 24"D
668AF-CC	Natural Cork / Natural Cork - Aluminum Trim	4"H X 5"W	79.5"H X 65"W X 24"D
668AG-DD	Porcelain Steel / Porcelain Steel - Aluminum Trim	4"H X 6"W	79.5"H X 77"W X 24"D
668AG-DC	Porcelain Steel / Natural Cork - Aluminum Trim	4"H X 6"W	79.5"H X 77"W X 24"D
668AG-HH	Dura-Rite / Dura-Rite - Aluminum Trim	4"H X 6"W	79.5"H X 77"W X 24"D
668AG-HC	Dura-Rite / Natural Cork - Aluminum Trim	4"H X 6"W	79.5"H X 77"W X 24"D
668AG-CC	Natural Cork / Natural Cork - Aluminum Trim	4"H X 6"W	79.5"H X 77"W X 24"D
668AH-DD	Porcelain Steel / Porcelain Steel - Aluminum Trim	4"H X 8"W	79.5"H X 101"W X 24"D
668AH-DC	Porcelain Steel / Natural Cork - Aluminum Trim	4"H X 8"W	79.5"H X 101"W X 24"D
668AH-HH	Dura-Rite / Dura-Rite - Aluminum Trim	4"H X 8"W	79.5"H X 101"W X 24"D
668AH-HC	Dura-Rite / Natural Cork - Aluminum Trim	4"H X 8"W	79.5"H X 101"W X 24"D
668AH-CC	Natural Cork / Natural Cork - Aluminum Trim	4"H X 8"W	79.5"H X 101"W X 24"D



MooreCo, Inc.
 2885 Lorraine Avenue | Temple, TX 76501
 p: 800.749.2258 | f: 866.888.7483
www.moorecoinc.com