

Seed 4-Leg Commercial

Product No: SG.SD.C4L.18.6XX.7XX.PL

SHELL:

Seat is designed as a single-piece injection-molded shell of polypropylene with integrated attachment features including a structural front hook, rear snaps, and screw bosses.

FRAME:

4-Leg Commercial frame is constructed of two .75" diameter 14 ga steel tubes, connected by a .75" diameter 14 ga steel tube used to snap into the frame. The shell uses integrated snaps to attach to a welded 12 ga steel bracket with two built-in clips. The bracket is also screwed in with two #10 x 1" plastite screws. Poly shell chairs are rated for use up to 250lbs. Frame is available in three powder coat finish options.

GLIDES:

Nylon glides are inserted into the bottom of each leg.

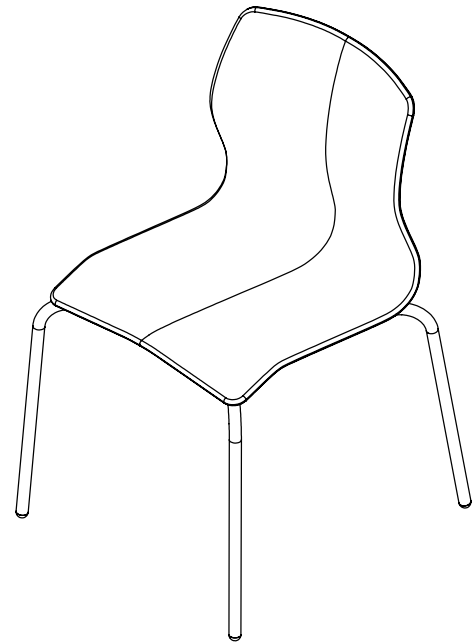

COMPLIANCE:

SCS Indoor Advantage Gold certified.

Meets or exceeds BIFMA testing.

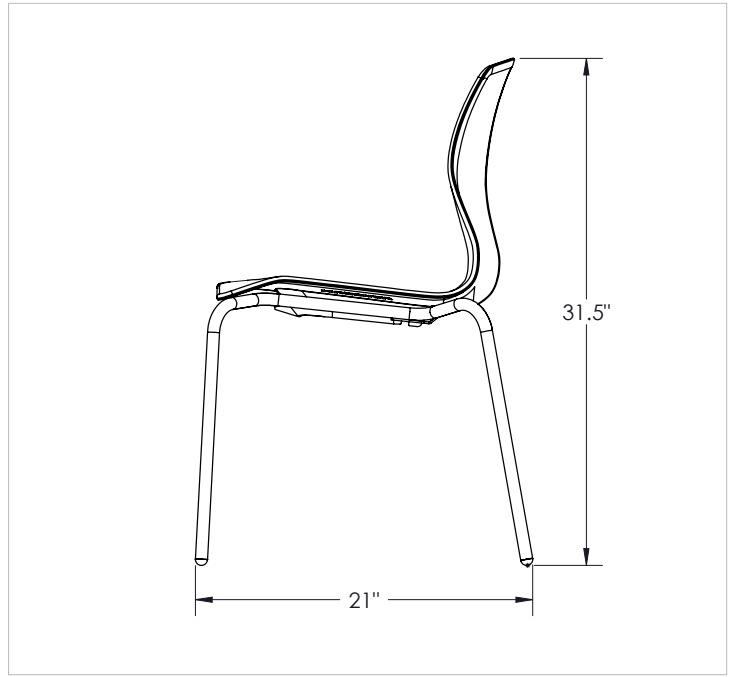
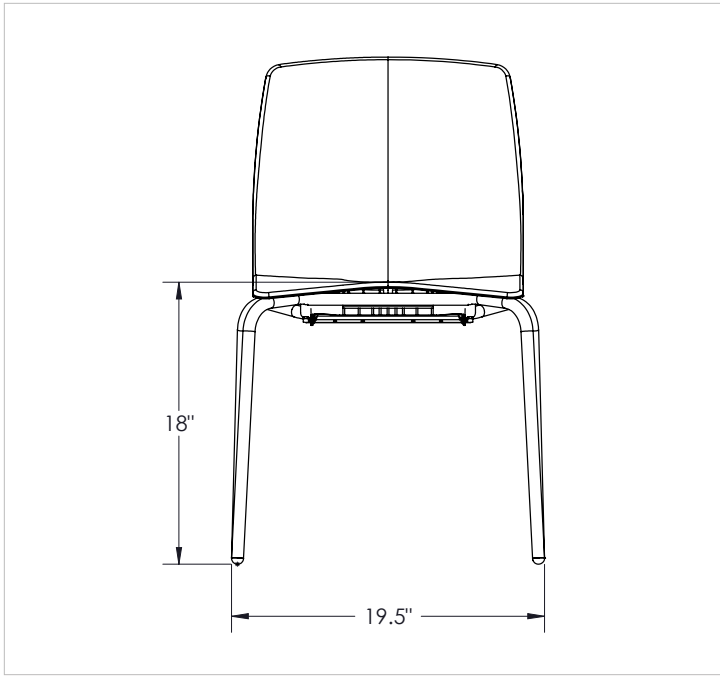

DIMENSIONS:

Base Model No.	Description	Seat Height	Overall Depth	Overall Width
SG.SD.C4L.18.6XX.7XX.PL	Seed - 4-Leg Commercial Frame	18"	21.5"	20.3"