

Seed 4-Leg Educational

Product No: SG.SD.E4L.16.6XX.7XX.PL, SG.SD.E4L.18.6XX.7XX.PL

SHELL:

Seat is designed as a single-piece injection-molded shell of polypropylene with integrated attachment features including a structural front hook, rear snaps, and screw bosses.

FRAME:

4-Leg Educational frame is constructed of two 1" diameter 14 ga steel tubes, connected by a .75" diameter 14 ga steel tube used to snap into the frame. The shell uses integrated snaps to attach to a welded 12 ga steel bracket with two built-in clips. The bracket is also screwed in with two #10 x 1" plastite screws. Poly shell chairs are rated for use up to 250lbs. Frame is available in three powder coat finish options.

GLIDE:

Steel swivel glides utilize an internal star clip and are standard in white nylon to accommodate a variety of flooring types.

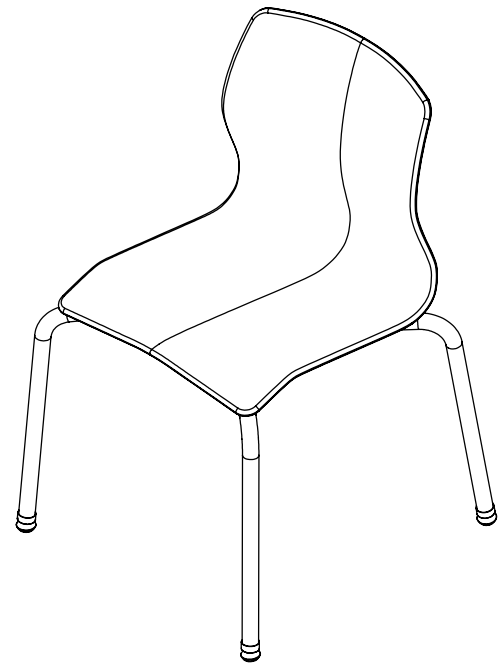

COMPLIANCE:

SCS Indoor Advantage Gold certified.

Meets or exceeds BIFMA testing.

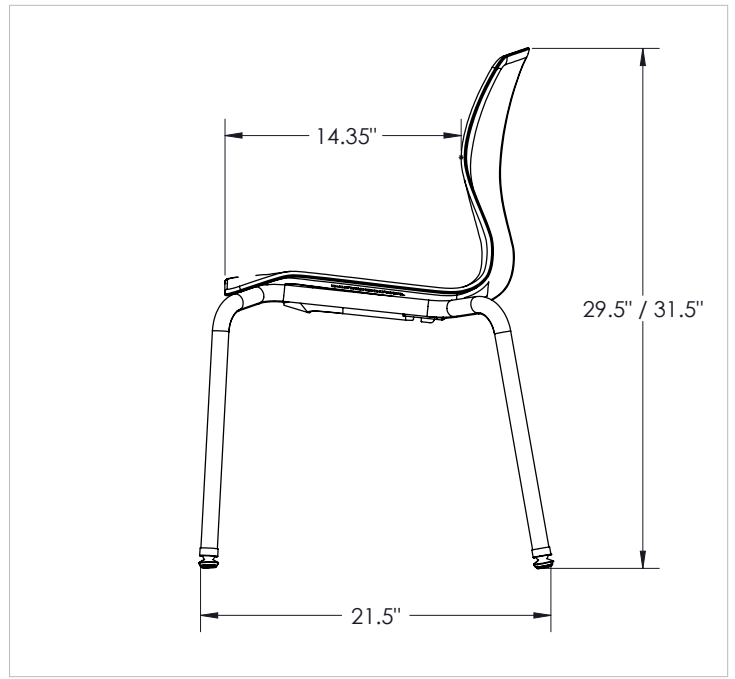
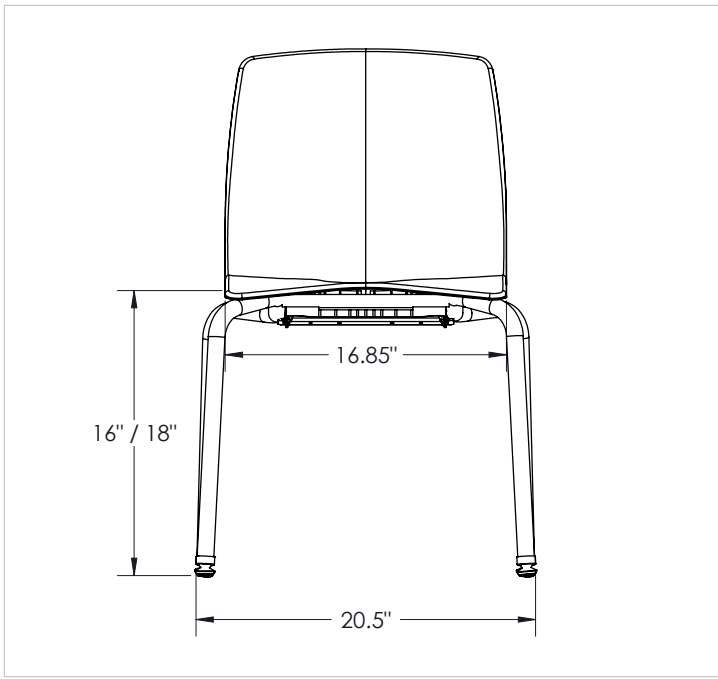

DIMENSIONS:

Base Model No.	Description	Seat Height	Overall Depth	Overall Width
SG.SD.E4L.16.6XX.7XX.PL	Seed - 4-Leg Educational Frame - 16"	16"	21.5"	20.5"
SG.SD.E4L.18.6XX.7XX.PL	Seed - 4-Leg Educational Frame - 18"	18"	21.5"	20.5"



Vanerum North America
 2885 Lorraine Avenue | Temple, TX 76501
 p: 800.749.2258 | f: 866.888.7483
 www.vanerumna.com