

# Visionary Move Mobile

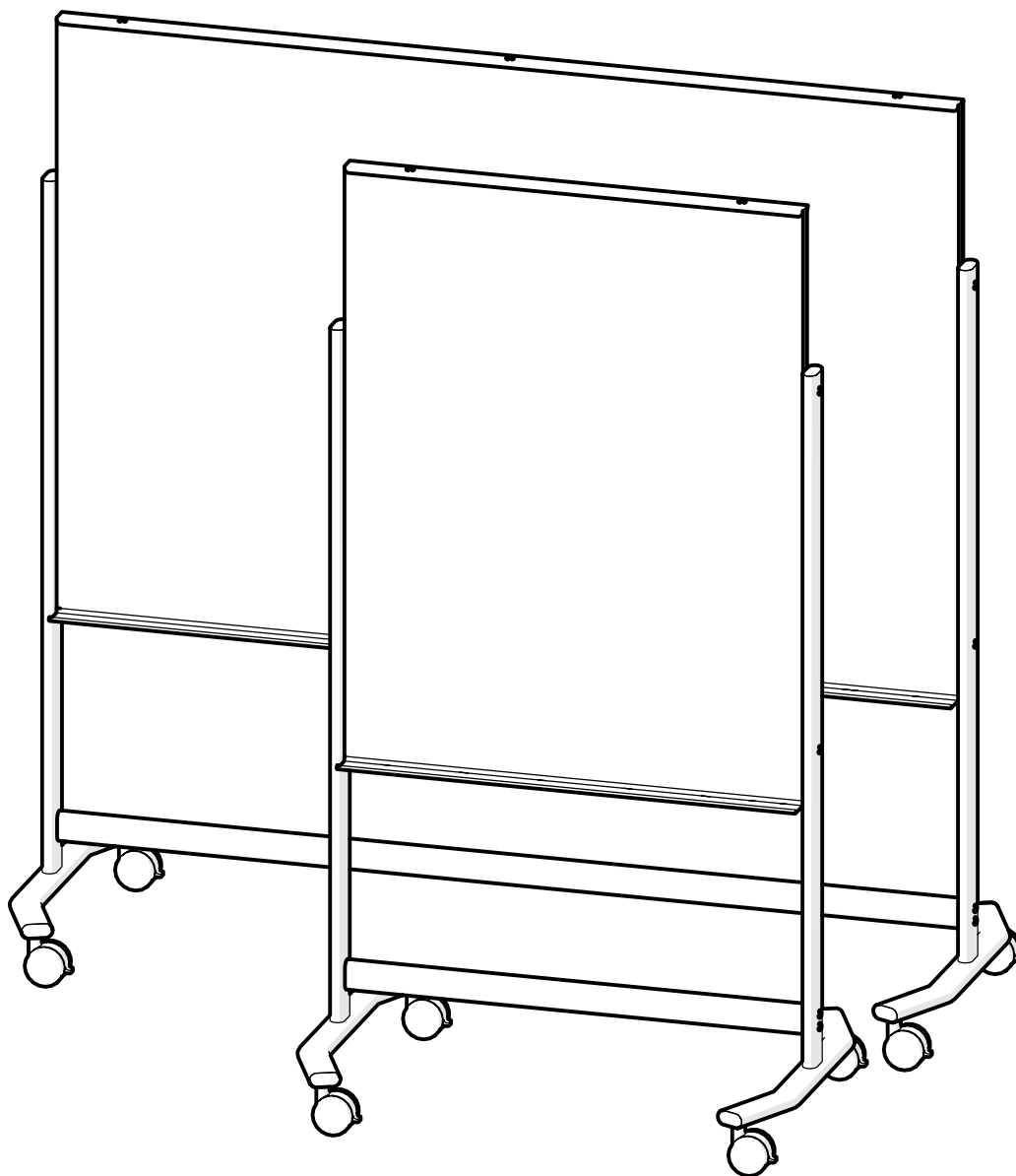

Part Numbers: 74950, 74950B, 74951, 74951B, 74965-XXXX, 74973-XXXX



 **ASSEMBLY INSTRUCTIONS**   
DO NOT THROW AWAY!

INSTRUCCIONES DE ENSEMBLAJE  
NO LA TIRE

INSTRUCTIONS DE MONTAGE  
NE PAS JETER

## Parts List

P1 - Glass Board

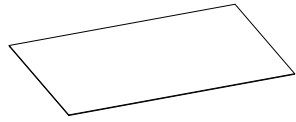

x2

P2 - Leg

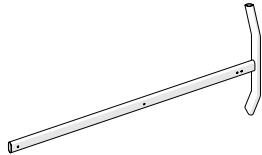

x2

P3 - Horizontal Tube

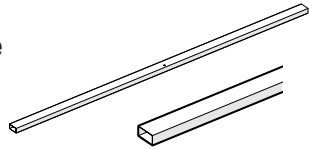

x2

P4 - Vertical Tube

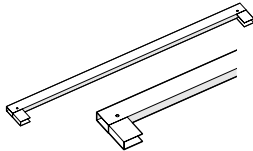

x2

P5 - Bottom Post

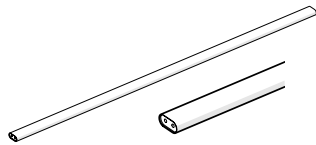

x1

P6 - Tray

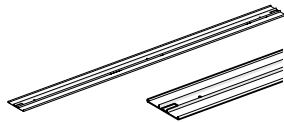

x1

P7 - Top Cap

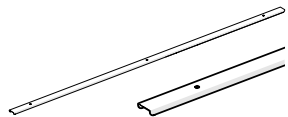

x1

## Hardware

A - 1/4" x 15mm



x6

B - 1/4" x 50mm

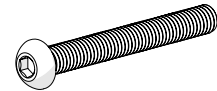

x8

C1 - Locking Caster

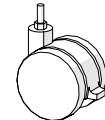

x2

C2 - Non-Locking Caster

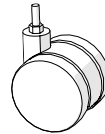

x2

D - Caster Wrench

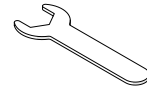

x1

E - Allen Wrench

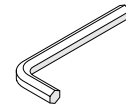

x1

F - Lock Washer



x4

## WARNINGS AND DISCLAIMERS

Review full assembly instructions and check that all parts are present before beginning assembly. Heavy or large furniture may require multiple persons in order to properly assemble. If you have questions regarding assembly, contact the manufacturer before continuing. Damage due to incorrect assembly may not be covered by warranty. Do not use product unless all screws are tight. Check all screws for tightness at least every six months. If parts are broken, missing, damaged, or worn, stop use of the product until repairs are made by your dealer using factory authorized parts.

## ADVERTENCIAS Y RENUNCIAS

Previo a comenzar el proceso de ensamblaje favor de revisar las instrucciones y asegurarse que cuenta con todas las partes y materiales necesarios. Es posible que los muebles grandes o pesados, requieran mas de una persona para ensamblarlos correctamente. Por favor contacte al fabricante directamente si tiene alguna duda o pregunta antes de continuar con el proceso de armado del producto. La garantía no cubrirá daños que ocurrieron por errores cometidos durante el proceso de ensamblaje. Todos los tornillos deben estar ajustados previo el uso del producto. Debe revisar los tornillos periódicamente, por lo menos cada seis meses y asegurarse de que estén bien ajustados. Por favor detenga el uso del producto si partes del producto se pierden, rompen, se deterioran por uso o se rompen. Favor de contactar a su distribuidor para que le envíen las partes necesarias o realice las reparaciones necesarias con partes autorizadas por el fabricante.

## AVERTISSEMENTS

Avant de commencer l'assamblage veuillez consulter les instructions complètes et vérifier si vous avez toutes les pièces nécessaires. Il est possible que plusieurs personnes soient nécessaires pour assemble des meubles grand ou lourds. En cas de doute sur l'assamblage contactez le fabricant avant de continuer. Les dommages encourus pendant l'assamblage ne seront pas couvert par la garantie. Ne pas utiliser le produit sans vérifier que tous les vis soient serrées. Vérifiez que les vis sont serrées au moins tous le 6 mois. Si aucune pièce se casse, manque, est endommagée ou usée, arrêtez d'utiliser de produit jusqu'à ce que le vendeur le repaire a l'aide de pièces autorisées par la fabricant.

## WARRANTY

For full product warranty details, please visit:

Para obtener información sobre la garantía del producto, consulte este sitio (ingles):

Pour plus d'informations sur la garantie du produit, consultez ce site (anglais):

<http://moorecoinc.com/warranty>

## CARE & MAINTENANCE

For questions on assembly or missing/damaged parts, please contact us using the following information.

Para preguntas sobre el ensamblaje o piezas faltantes o dañadas, por favor contáctenos usando la siguiente información.

Pour toute question sur le montage l'assamblage manquantes ou endommagées, veuillez nous contacter en utilisant les l'information ci-dessous.

Email:

[support@moorecoinc.com](mailto:support@moorecoinc.com)

Phone:

**1.800.749.2258**

(Monday - Friday, 8AM - 5PM

Central Time)

## PRODUCT REGISTRATION

To register your product for warranty, please visit:

Para registrar la garantía del producto, vea este sitio (en ingles):

Pour enregistrer la garantie de votre produit, consultez ce site (en anglais):

<https://moorecoinc.com/register>

## STEP 1

Place Lock Washer on each Caster stem then screw in Casters to Leg and tighten with Caster Wrench. Use one Locking Caster and one Non-Locking Caster per Leg. Repeat for second Leg.

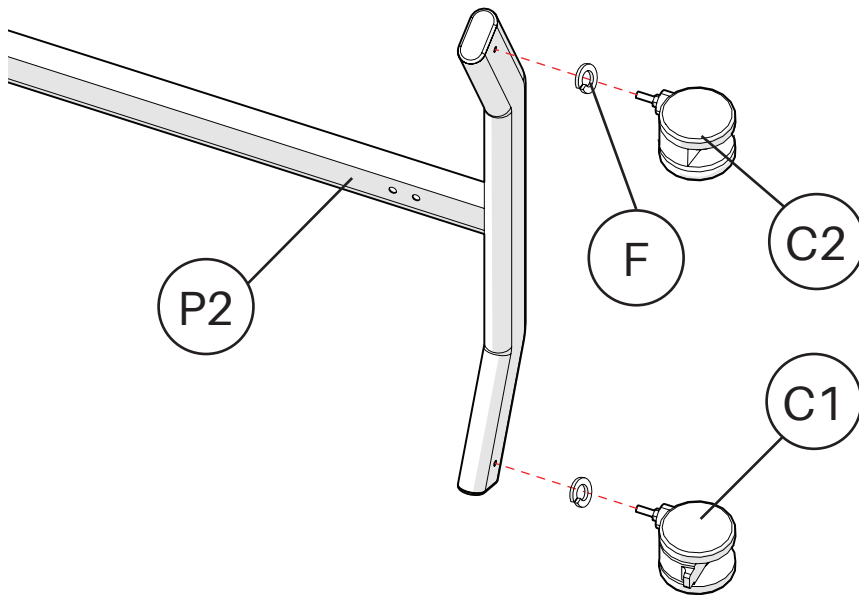

## STEP 2

Connect Bottom Post to Legs using two screws (B) per Leg.

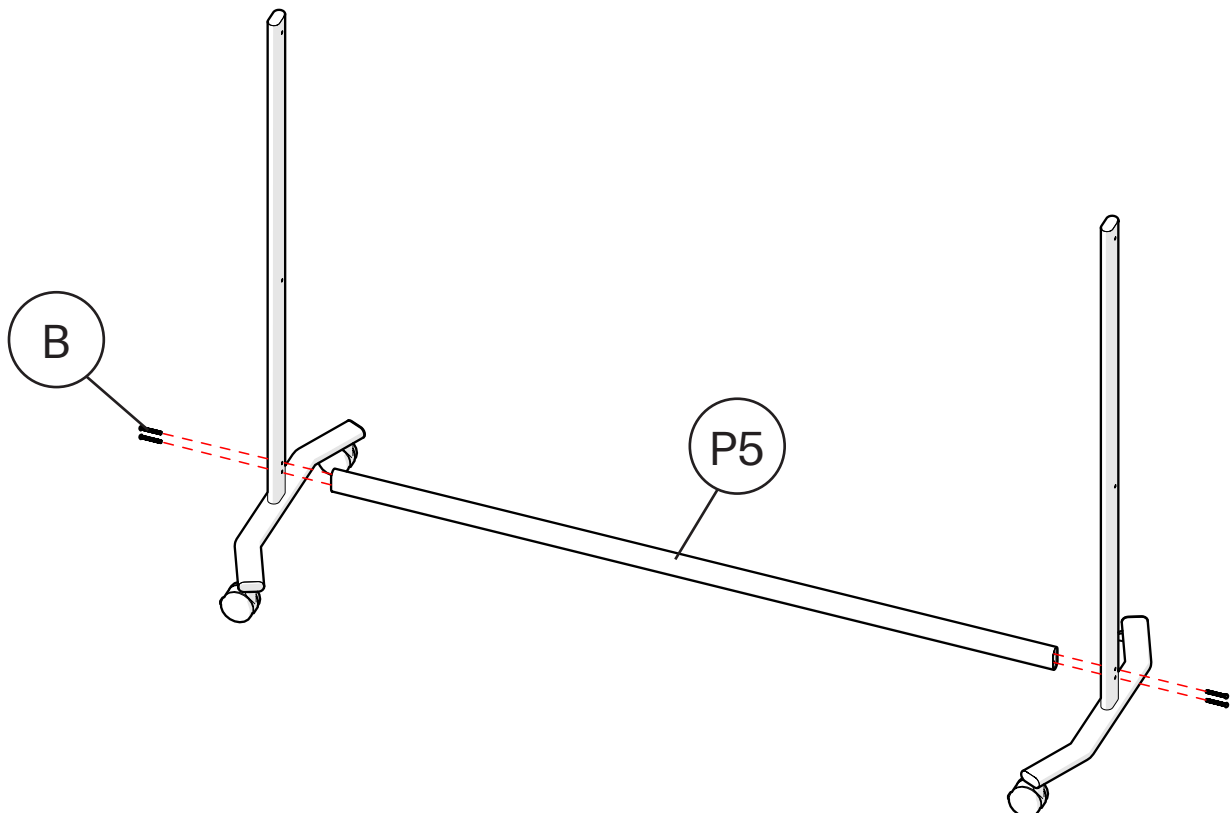

### STEP 3

Connect Vertical and Horizontal Tubes as shown. Make sure the side holes on both Vertical Tubes are oriented the same way and holes on Horizontal Tubes are facing outward.

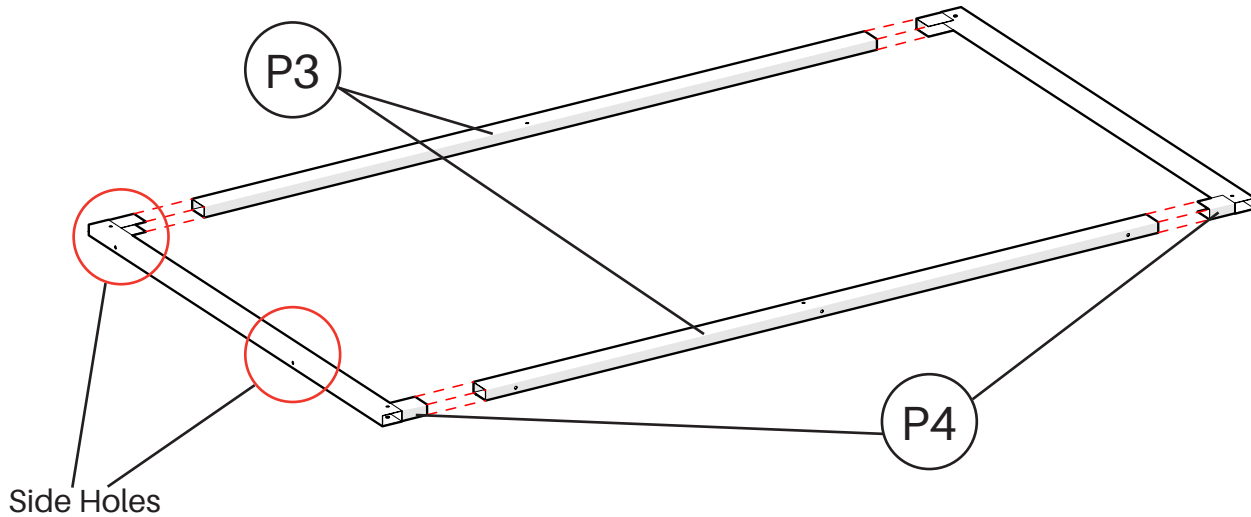

### STEP 4

Position frame in between Legs and secure with two screws (B) on each side. Make sure frame is oriented correctly.

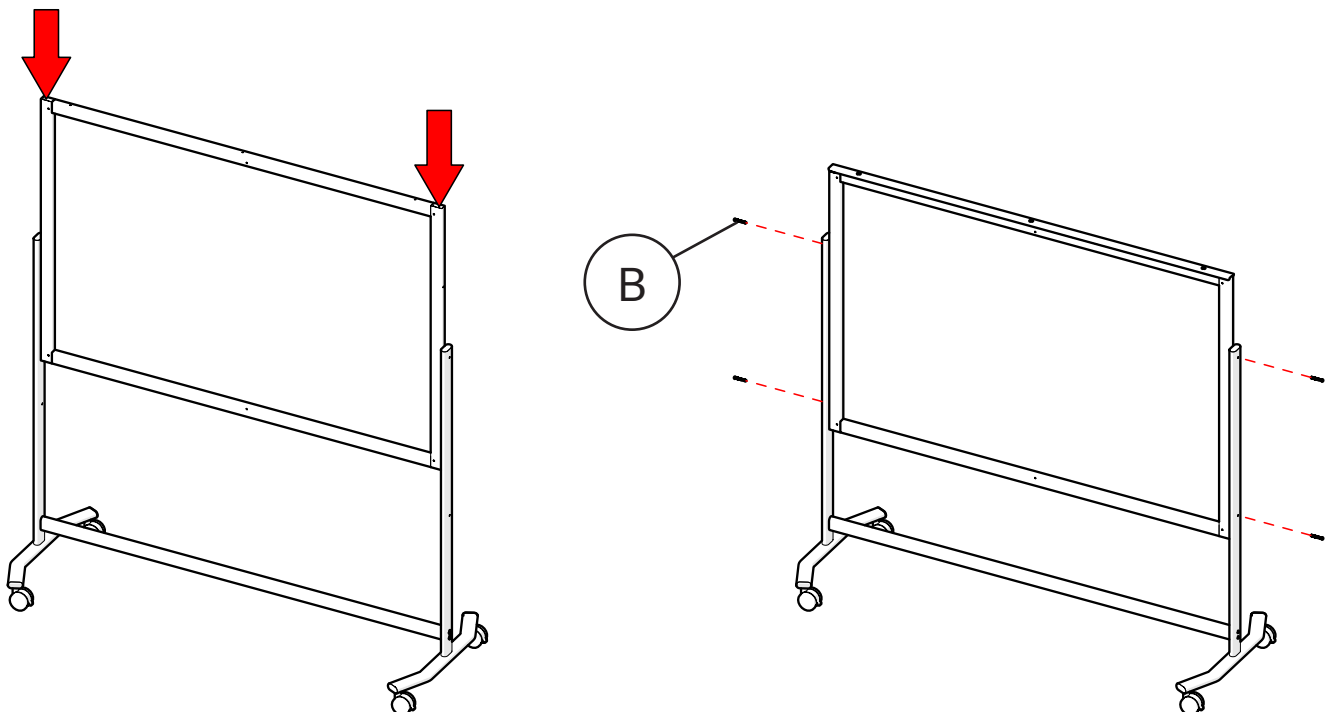

## STEP 5

Attach Tray to underside of frame using three screws (A).

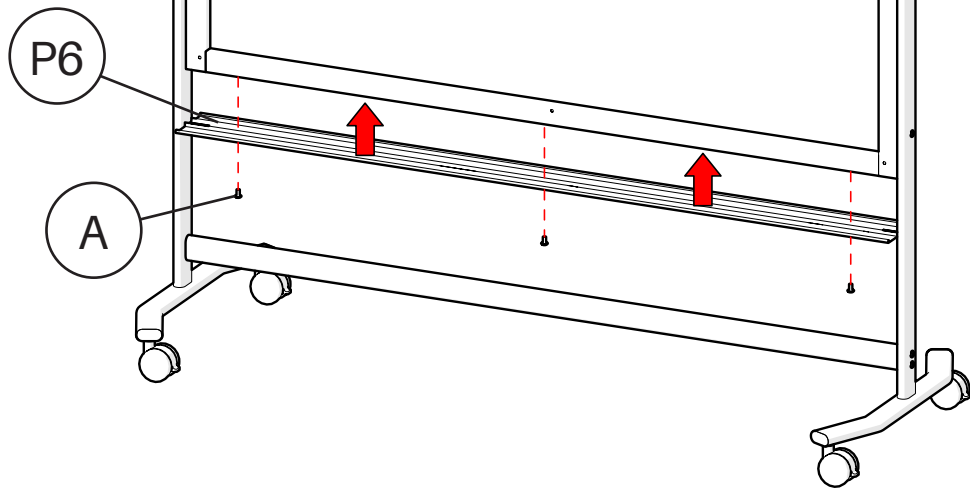

## STEP 6

Peel off adhesive cover on all four front and back pieces of double-sided tape on frame. Place Glass Boards by inserting bottom of each board in tray on both sides and holding flush against either face of frame pressing firmly into tape.

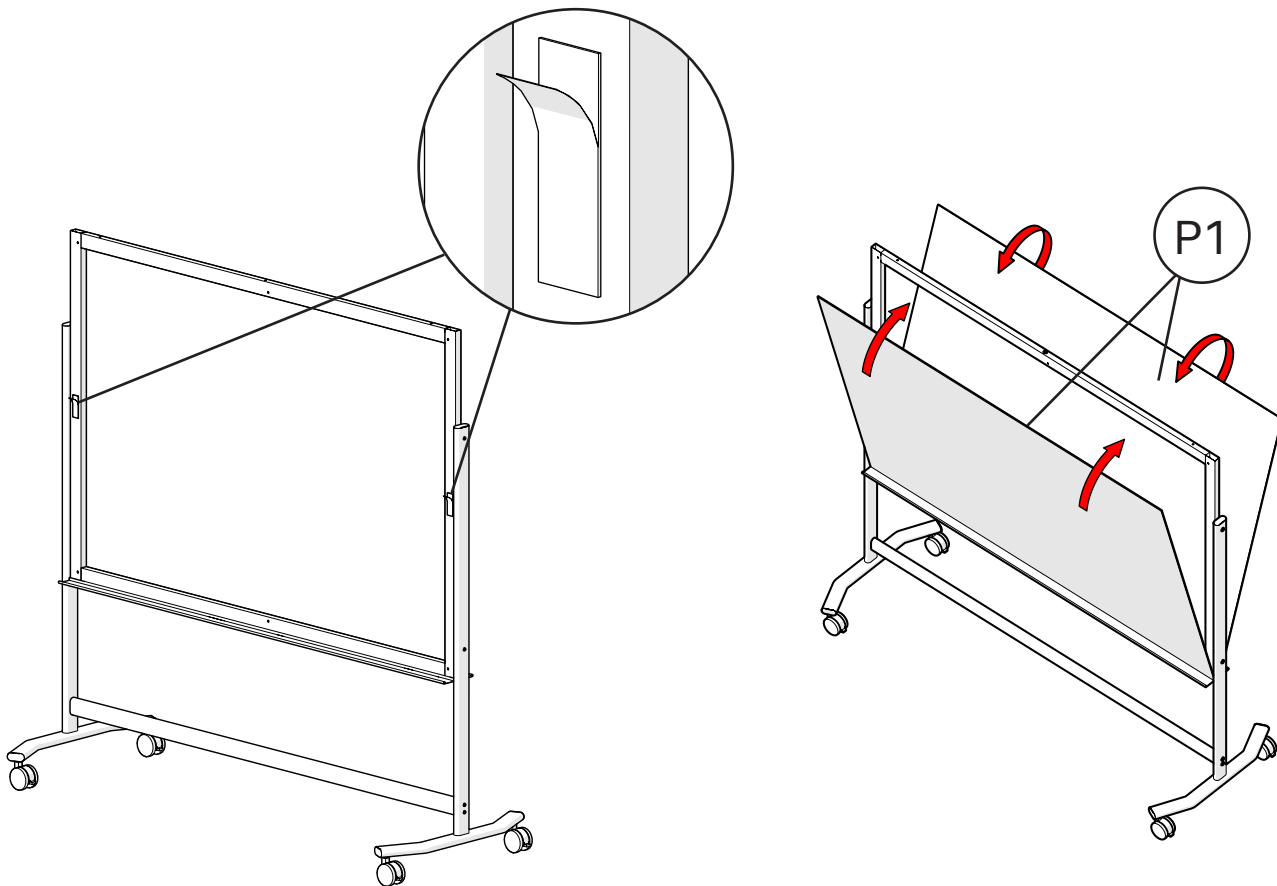

## STEP 7

Secure boards in place by fitting Top Cap over top edge of boards and screwing into top of frame with three screws (A).

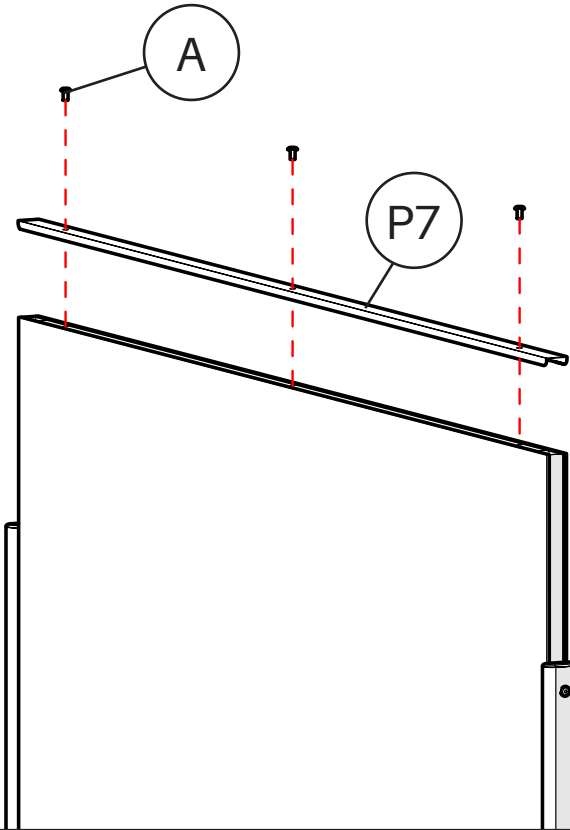

**THIS COMPLETES ASSEMBLY INSTRUCTION**