

Compass MakerSpace Tables

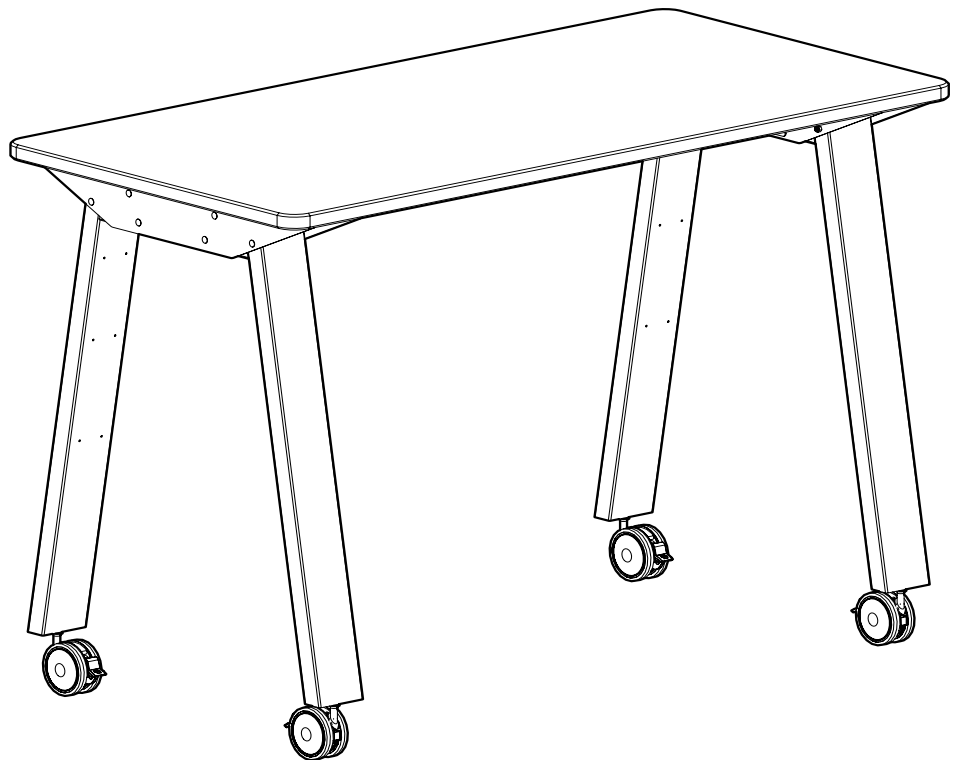

Part Numbers: 9169X-X-XXXX, 9169X-X-BUTCHER



 **ASSEMBLY INSTRUCTIONS**  **DO NOT THROW AWAY!**

INSTRUCCIONES DE ENSEMBLAJE
NO LA TIRE

INSTRUCTIONS DE MONTAGE
NE PAS JETER

Parts

P1 - Table Top
(size will vary)



x1

P2 - Leg Bracket

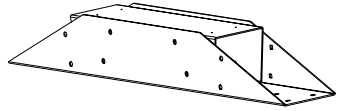

x2

P3 - Leg
(length will vary)

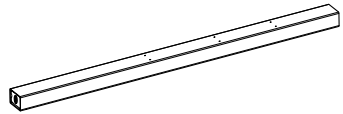

x4

P4 - Support Bracket
(length will vary)

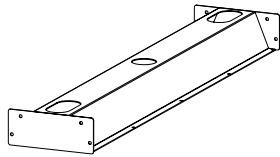

x1

Hardware

A - #10 x 1" Wood Screw

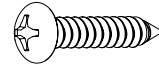

x22
(x18 - 48")

B - 1/4-20 x 3" Bolt



x16

C - 1/4-20 Lock Nut

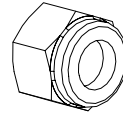

x16

D - Locking Casters

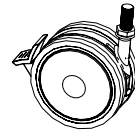

x2

E - Non-Locking Casters

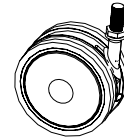

x2

F - Lock Washer

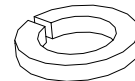

x4

G - Caster Wrench

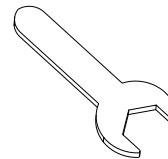

x1



ASSEMBLY INSTRUCTIONS
DO NOT THROW AWAY!



INSTRUCCIONES DE ENSEMBLAJE
NO LA TIRE

INSTRUCTIONS DE MONTAGE
NE PAS JETER

WARNINGS AND DISCLAIMERS

Review full assembly instructions and check that all parts are present before beginning assembly. Heavy or large furniture may require multiple persons in order to properly assemble. If you have questions regarding assembly, contact the manufacturer before continuing. Damage due to incorrect assembly may not be covered by warranty. Do not use product unless all screws are tight. Check all screws for tightness at least every six months. If parts are broken, missing, damaged, or worn, stop use of the product until repairs are made by your dealer using factory authorized parts.

ADVERTENCIAS Y RENUNCIAS

Previo a comenzar el proceso de ensamblaje favor de revisar las instrucciones y asegurarse que cuenta con todas las partes y materiales necesarios. Es posible que los muebles grandes o pesados, requieran mas de una persona para ensamblarlos correctamente. Por favor contacte al fabricante directamente si tiene alguna duda o pregunta antes de continuar con el proceso de armado del producto. La garantía no cubrirá daños que ocurrieron por errores cometidos durante el proceso de ensamblaje. Todos los tornillos deben estar ajustados previo el uso del producto. Debe revisar los tornillos periódicamente, por lo menos cada seis meses y asegurarse de que estén bien ajustados. Por favor detenga el uso del producto si partes del producto se pierden, rompen, se deterioran por uso o se rompen. Favor de contactar a su distribuidor para que le envíen las partes necesarias o realice las reparaciones necesarias con partes autorizadas por el fabricante.

AVERTISSEMENTS

Avant de commencer l'assamblage veuillez consulter les instructions complètes et vérifier si vous avez toutes les pièces nécessaires. Il est possible que plusieurs personnes soient nécessaires pour assemble des meubles grand ou lourds. En cas de doute sur l'assamblage contactez le fabricant avant de continuer. Les dommages encourus pendant l'assamblage ne seront pas couvert par la garantie. Ne pas utiliser le produit sans vérifier que tous les vis soient serrées. Vérifiez que les vis sont serrées au moins tous le 6 mois. Si aucune pièce se casse, manque, est endommagée ou usée, arrêtez d'utiliser de produit jusqu'à ce que le vendeur le repaire a l'aide de pièces autorisées par la fabricant.

WARRANTY

For full product warranty details, please visit:

Para obtener información sobre la garantía del producto, consulte este sitio (ingles):

Pour plus d'informations sur la garantie du produit, consultez ce site (anglais):

<http://moorecoinc.com/warranty>

CARE & MAINTENANCE

For questions on assembly or missing/damaged parts, please contact us using the following information.

Para preguntas sobre el ensamblaje o piezas faltantes o dañadas, por favor contáctenos usando la siguiente información.

Pour toute question sur le montage l'assamblage manquantes ou endommagées, veuillez nous contacter en utilisant les l'information ci-dessous.

Email:

support@moorecoinc.com

Phone:

1.800.749.2258

(Monday - Friday, 8AM - 5PM

Central Time)

PRODUCT REGISTRATION

To register your product for warranty, please visit:

Para registrar la garantía del producto, vea este sitio (en ingles):

Pour enregistrer la garantie de votre produit, consultez ce site (en anglais):

<https://moorecoinc.com/register>

STEP 1

Attach two Leg Parts (P3) to the Leg Bracket (P2) using bolts (B) and nuts (C). Repeat step for other bracket.

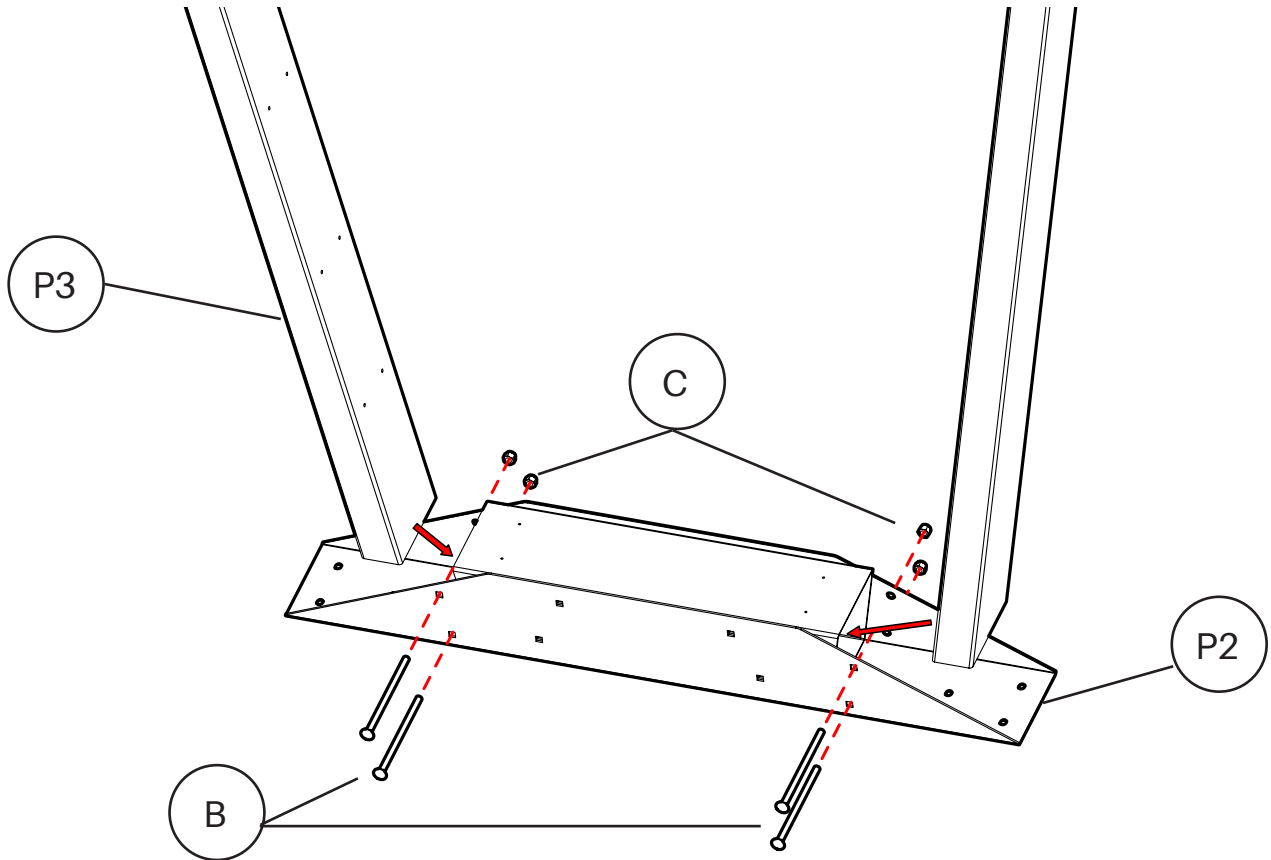

STEP 2

Connect Leg Bracket (P2) to Support Bracket (P4) using bolts (B) and nuts (C). Repeat step for other leg.

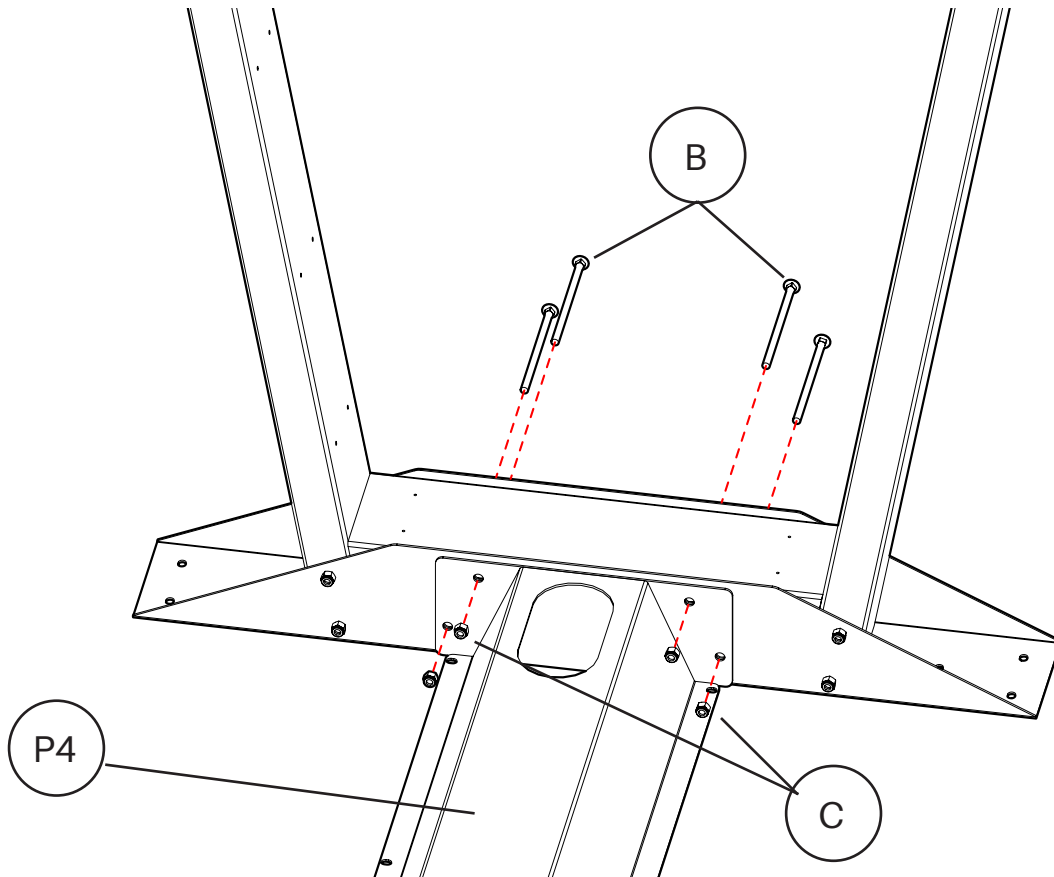

STEP 3

Lay frame on top of underside of table. Use holes as guides for placement.

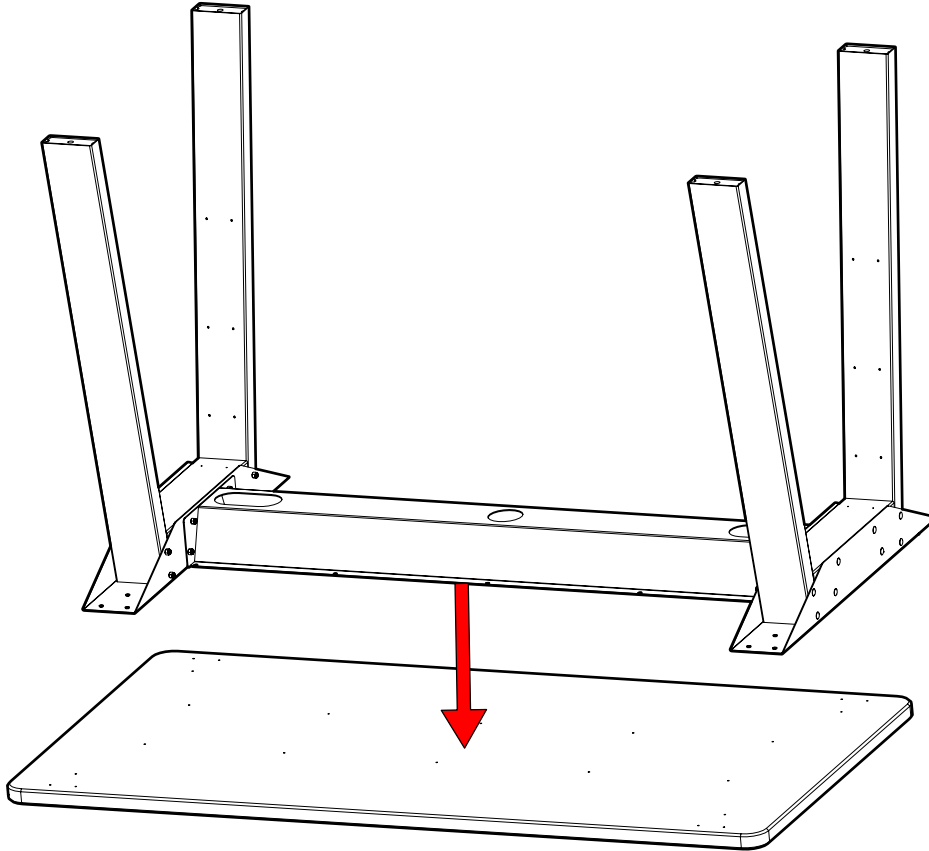

STEP 4

Mount frame to table using screws (A). Each leg receives six screws. Number of Support Bracket screws will vary by model.

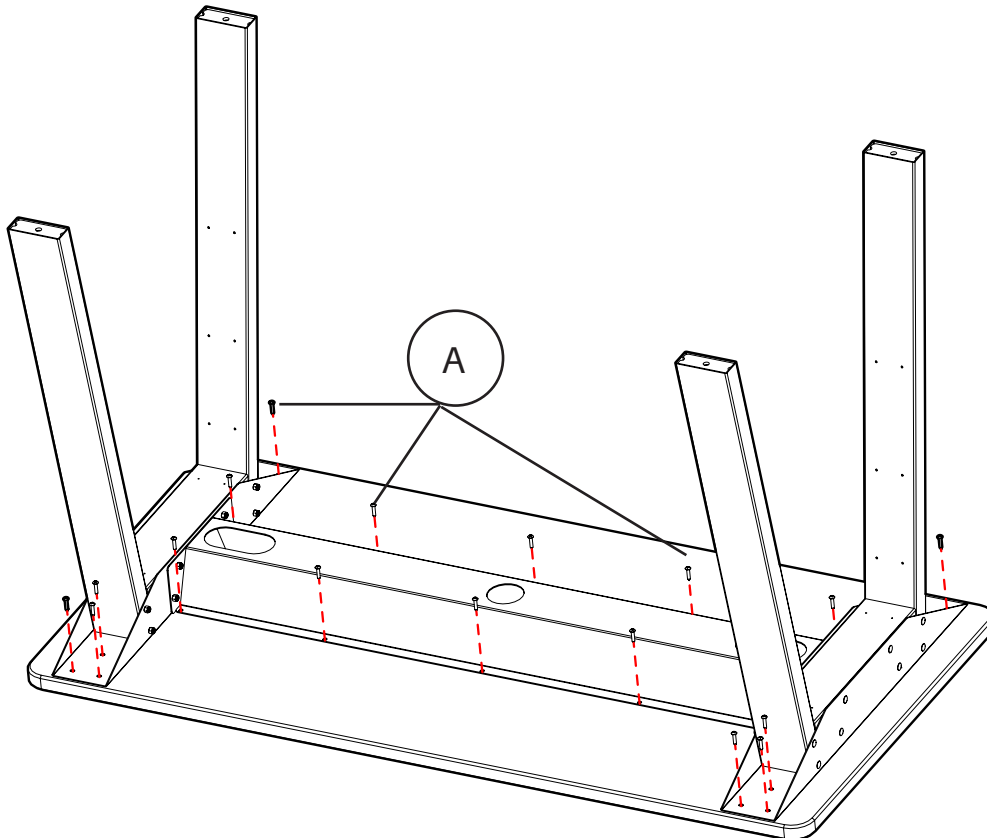

STEP 5

Install casters (D,E) with lock washers (F) using the wrench to screw in caster stems. Locking casters should be installed on opposite ends of the table.

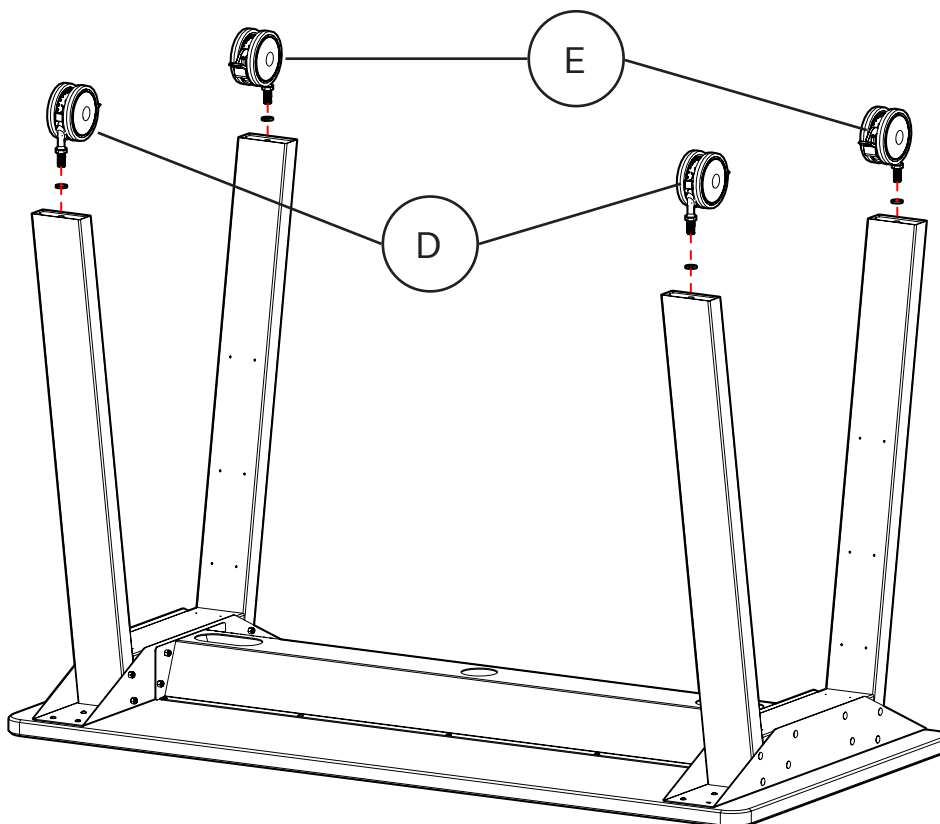

STEP 6

With two or more people, flip table upright.

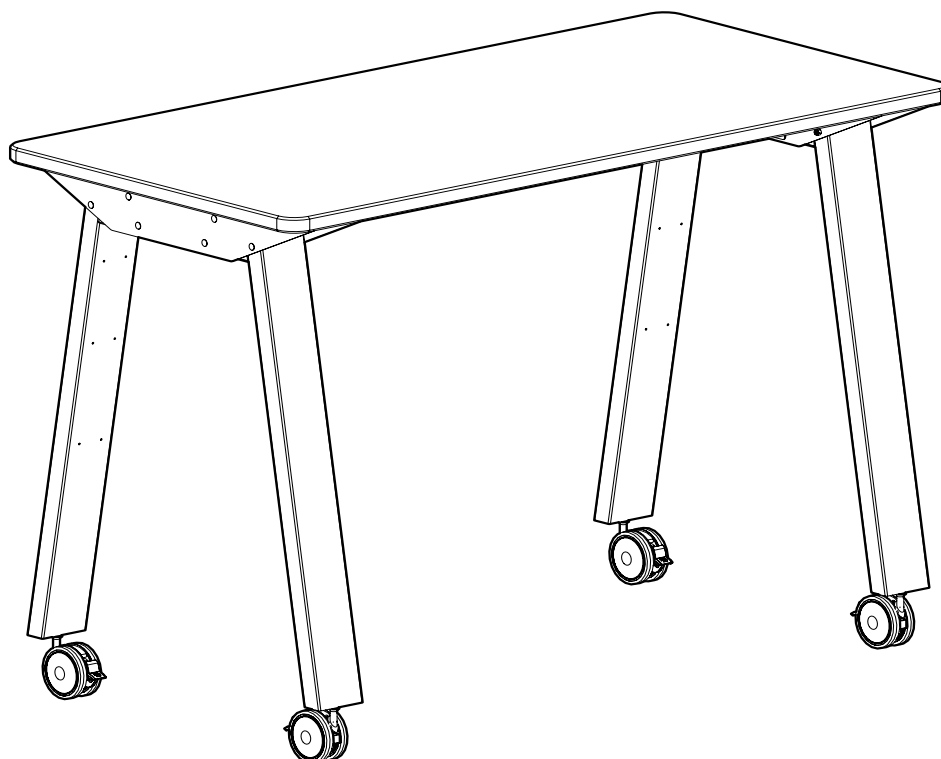

THIS COMPLETES ASSEMBLY INSTRUCTION