

Instructor Teacher's Desk

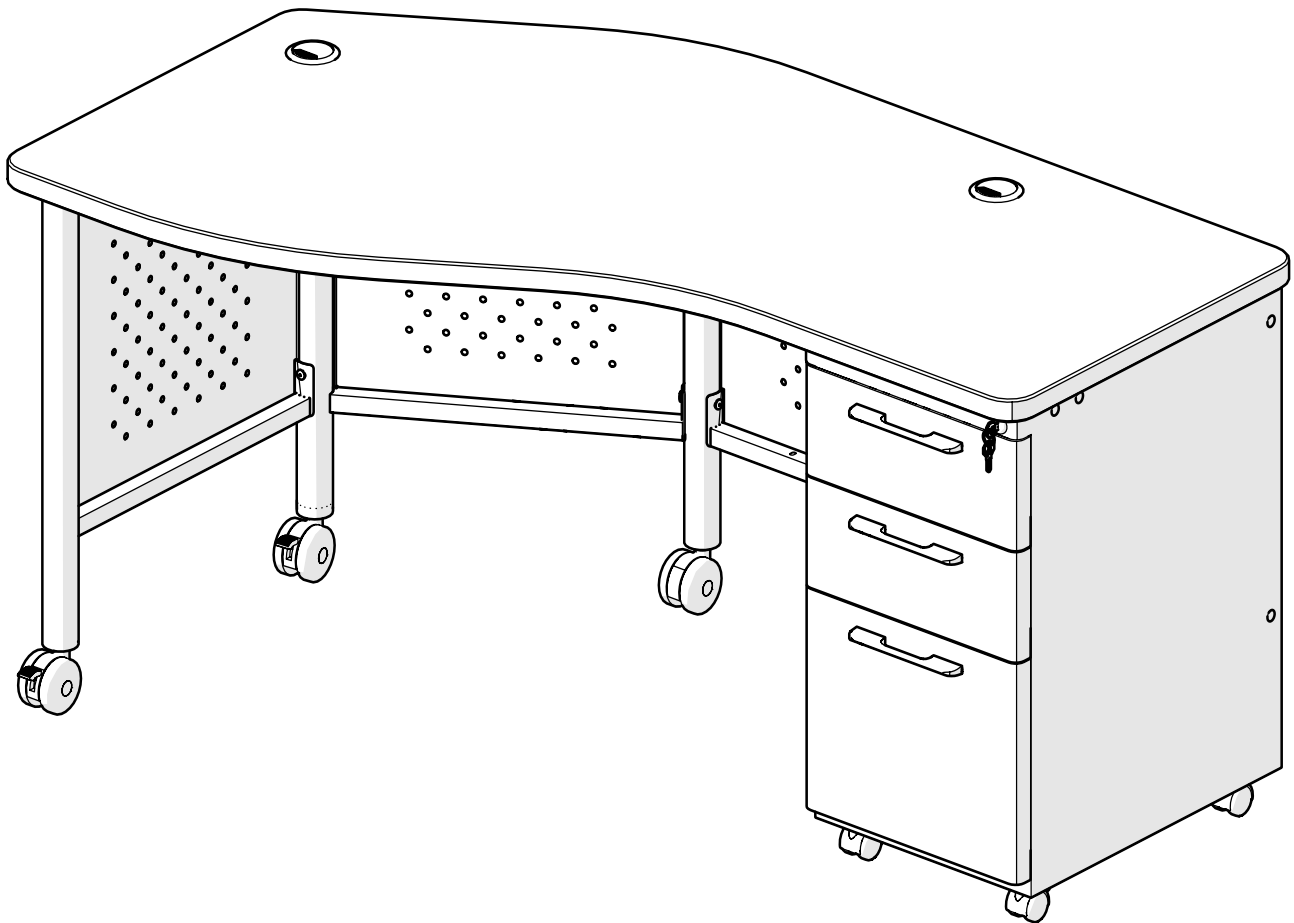

Part Numbers: 91785-XXXX-XX, 91786-XXXX-XX



 **ASSEMBLY INSTRUCTIONS**  **DO NOT THROW AWAY!**

INSTRUCCIONES DE ENSEMBLAJE
NO LA TIRE

INSTRUCTIONS DE MONTAGE
NE PAS JETER

Parts

P1 - Table Top x1

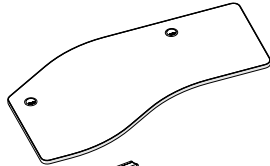

P2 - Leg Panel A x1

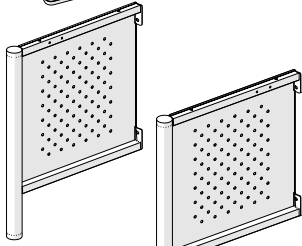

P3 - Leg Panel B x1

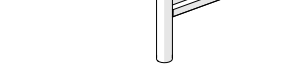

P4 - Back Panel x1

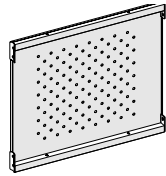

P5 - Leg Post x1

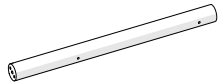

P6 - Crossbar x1

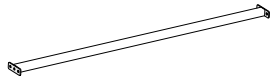

P7 - Pedestal Box x1



P7A - Handle x3

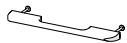

P7B - Divider Panel x1

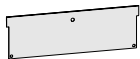

P7C - Divider Bar x1

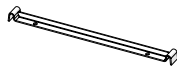

P7D - Pencil Tray x1

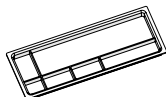

P7E - Key Set x1



Hardware

A - Wood Screw (#10 x 1.75") x6

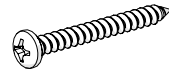

B - Machine Screw (M6 x 12mm) x12



C - Ped. Wood Screw (#12 x 1") x5

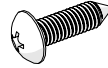

D - Ped. Caster Screw (M4 x 12mm Tap) x4



E - Pedestal Casters
E1 - Locking x2
E2 - Non-Locking x2

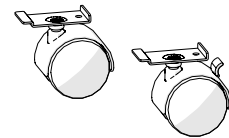

F - Leg Casters
F1 - Locking x2
F2 - Non-Locking x1

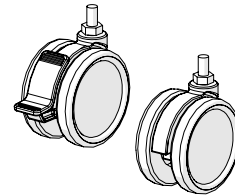

G - Lock Washer x3

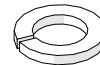

H - Plastic Side Cap x8

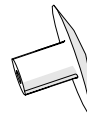

I - Plastic Back Cap x6



Tool(s):
-Allen Wrench
-Caster Wrench



WARNINGS AND DISCLAIMERS

Review full assembly instructions and check that all parts are present before beginning assembly. Heavy or large furniture may require multiple persons in order to properly assemble. If you have questions regarding assembly, contact the manufacturer before continuing. Damage due to incorrect assembly may not be covered by warranty. Do not use product unless all screws are tight. Check all screws for tightness at least every six months. If parts are broken, missing, damaged, or worn, stop use of the product until repairs are made by your dealer using factory authorized parts.

ADVERTENCIAS Y RENUNCIAS

Previo a comenzar el proceso de ensamblaje favor de revisar las instrucciones y asegurarse que cuenta con todas las partes y materiales necesarios. Es posible que los muebles grandes o pesados, requieran mas de una persona para ensamblarlos correctamente. Por favor contacte al fabricante directamente si tiene alguna duda o pregunta antes de continuar con el proceso de armado del producto. La garantía no cubrirá daños que ocurrieron por errores cometidos durante el proceso de ensamblaje. Todos los tornillos deben estar ajustados previo el uso del producto. Debe revisar los tornillos periódicamente, por lo menos cada seis meses y asegurarse de que estén bien ajustados. Por favor detenga el uso del producto si partes del producto se pierden, rompen, se deterioran por uso o se rompen. Favor de contactar a su distribuidor para que le envíen las partes necesarias o realice las reparaciones necesarias con partes autorizadas por el fabricante.

AVERTISSEMENTS

Avant de commencer l' assamblage veuillez consulter les instructions complètes et vérifier si vous avez toutes les pièces nécessaires. Il est possible que plusieurs personnes soient nécessaires pour assemble des meubles grand ou lourds. En cas de doute sur l' assamblage contactez le fabricant avant de continuer. Les dommages encourus pendant l' assamblage ne seront pas couvert par la garantie. Ne pas utiliser le produit sans vérifier que tous les vis soient serrées. Vérifiez que les vis sont serrées au moins tous le 6 mois. Si aucune pièce se casse, manque, est endommagée ou usée, arrêtez d' utiliser de produit jusqu'à ce que le vendeur le repaire a l'aide de pièces autorisées par la fabricant.

WARRANTY

For full product warranty details, please visit:

Para obtener información sobre la garantía del producto, consulte este sitio (ingles):

Pour plus d'informations sur la garantie du produit, consultez ce site (anglais):

<http://moorecoinc.com/warranty>

CARE & MAINTENANCE

For questions on assembly or missing/damaged parts, please contact us using the following information.

Para preguntas sobre el ensamblaje o piezas faltantes o dañadas, por favor contáctenos usando la siguiente información.

Pour toute question sur le montage l' assamblage manquantes ou endommagées, veuillez nous contacter en utilisant les l'information ci-dessous.

Email:

support@moorecoinc.com

Phone:

1.800.749.2258

(Monday - Friday, 8AM - 5PM

Central Time)

PRODUCT REGISTRATION

To register your product for warranty, please visit:

Para registrar la garantía del producto, vea este sitio (en ingles):

Pour enregistrer la garantie de votre produit, consultez ce site (en anglais):

<https://moorecoinc.com/register>

STEP 1

Open shelves and remove handle screws. Swap handles to front of shelves and insert handle screws from inside of shelves to secure handles in place.

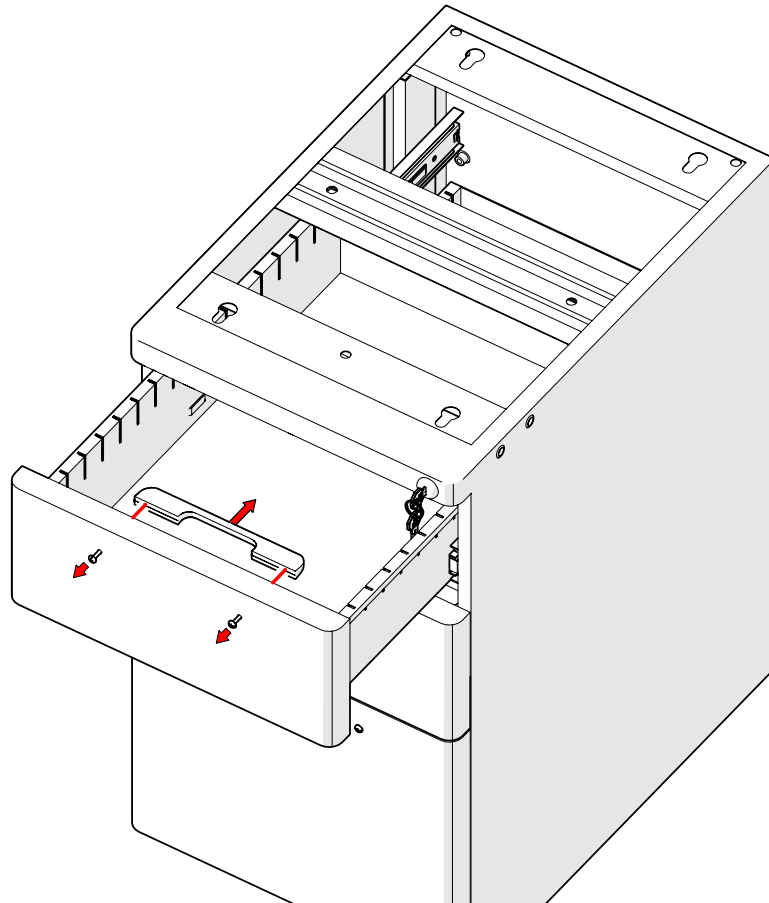

STEP 2

Remove shelves by first extending shelf to furthest setting until catch engages. To slide shelf off of rails, rotate visible catch levers on both sides of shelf either up or down while gently pulling shelf. Once both sides are free, shelf can be removed.

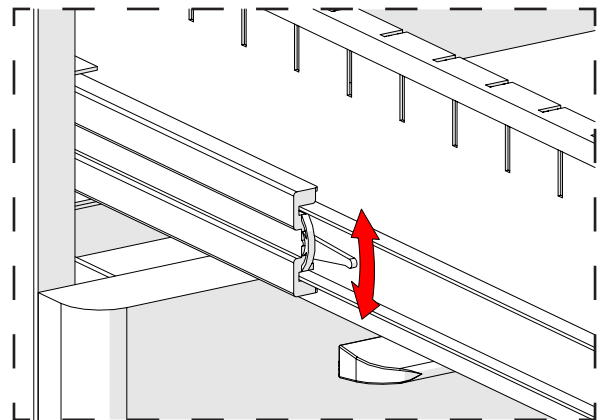
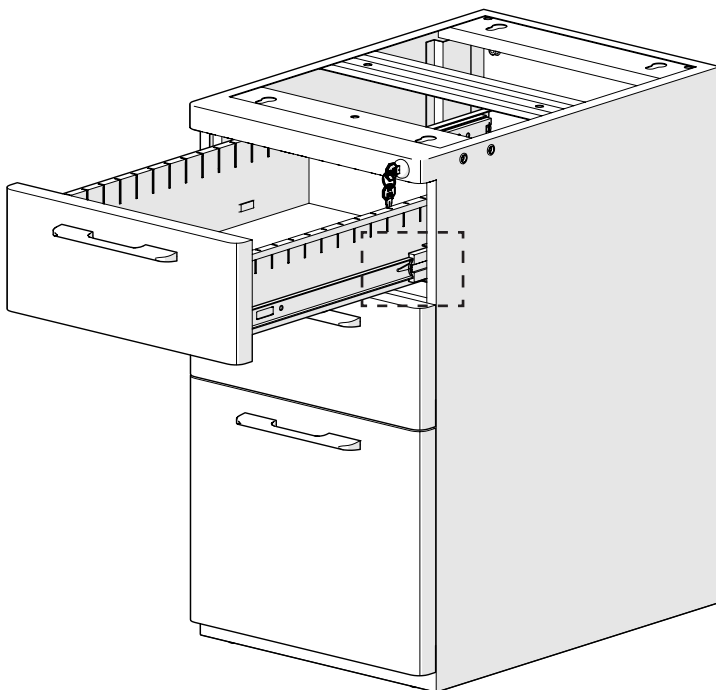

STEP 3A

FOR RIGHT HANDED DESK: Set top on protected surface so that underside is facing up. Install legs and modesty panel pieces as shown using machine and wood screws provided. Use pre-drilled holes for proper panel alignment. (See STEP 3B for Left Handed Desk).

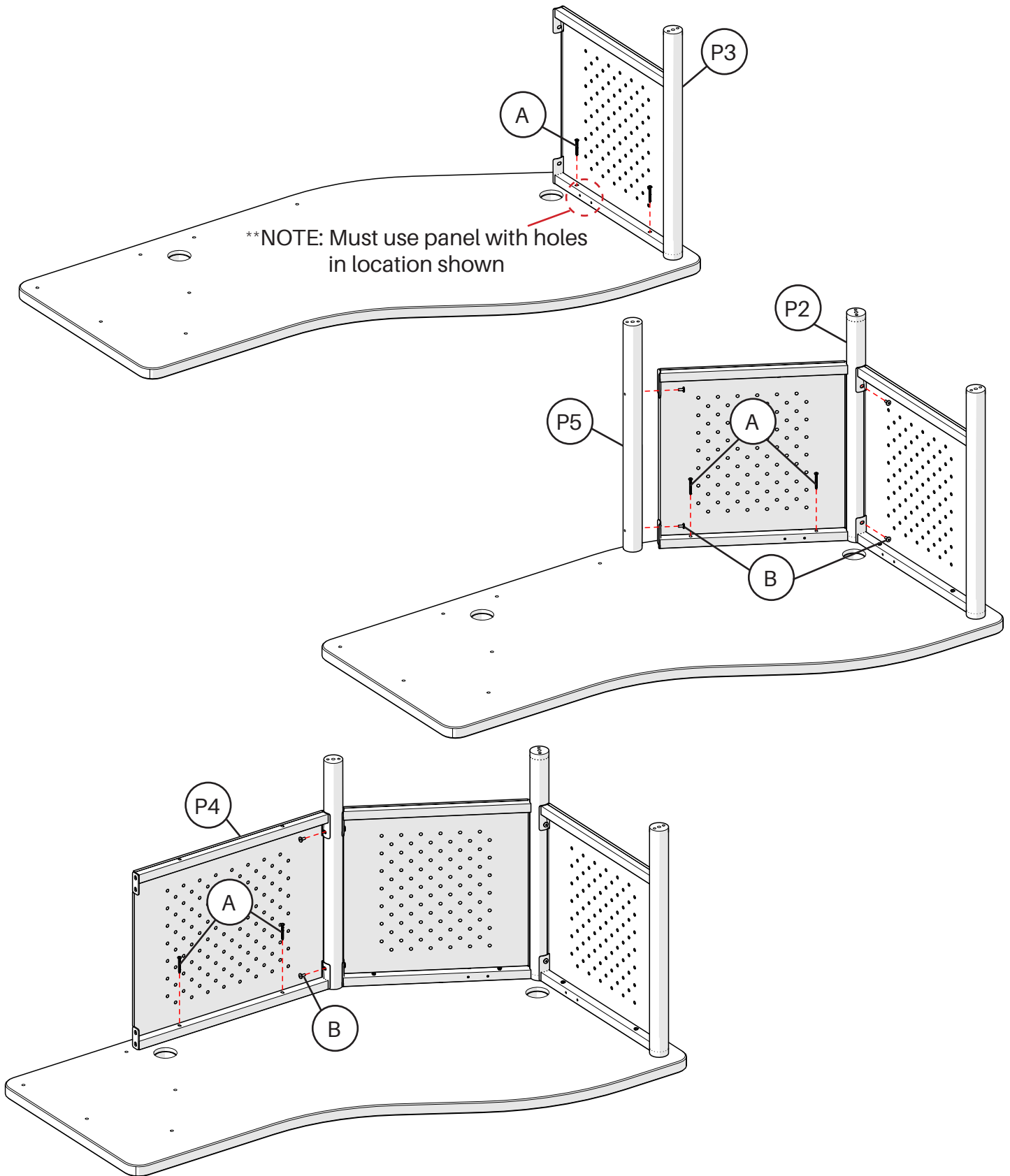

STEP 3B

FOR LEFT HANDED DESK: Set top on protected surface so that underside is facing up. Install legs and modesty panel pieces as shown using machine and wood screws provided. Use pre-drilled holes for proper panel alignment.

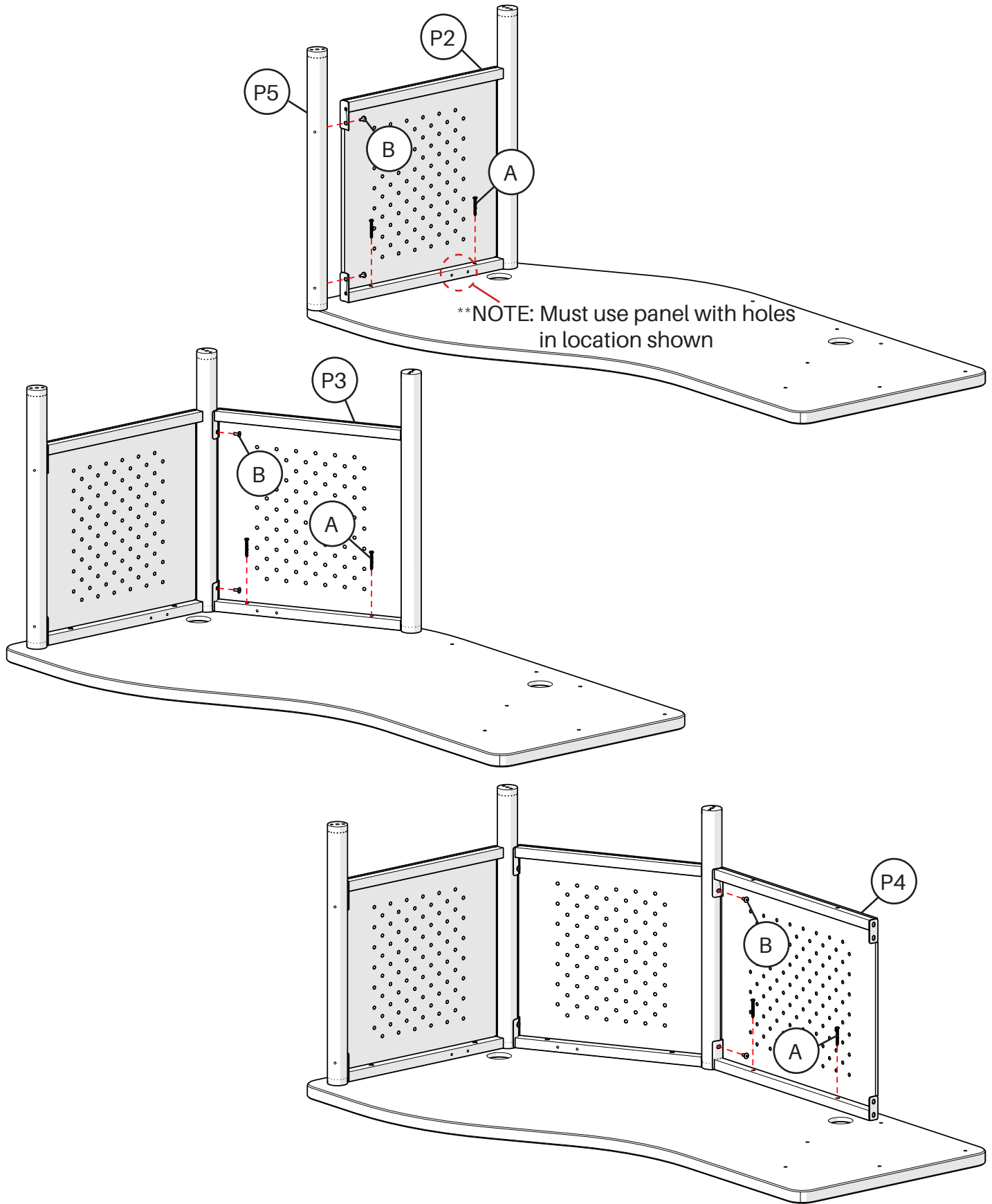

STEP 4

Set empty pedestal box upside down on top in position shown. Secure to panel with two screws through side inserts. (Instructions that follow depict right handed desk installation. For left handed desk installation part positions will be mirrored.)

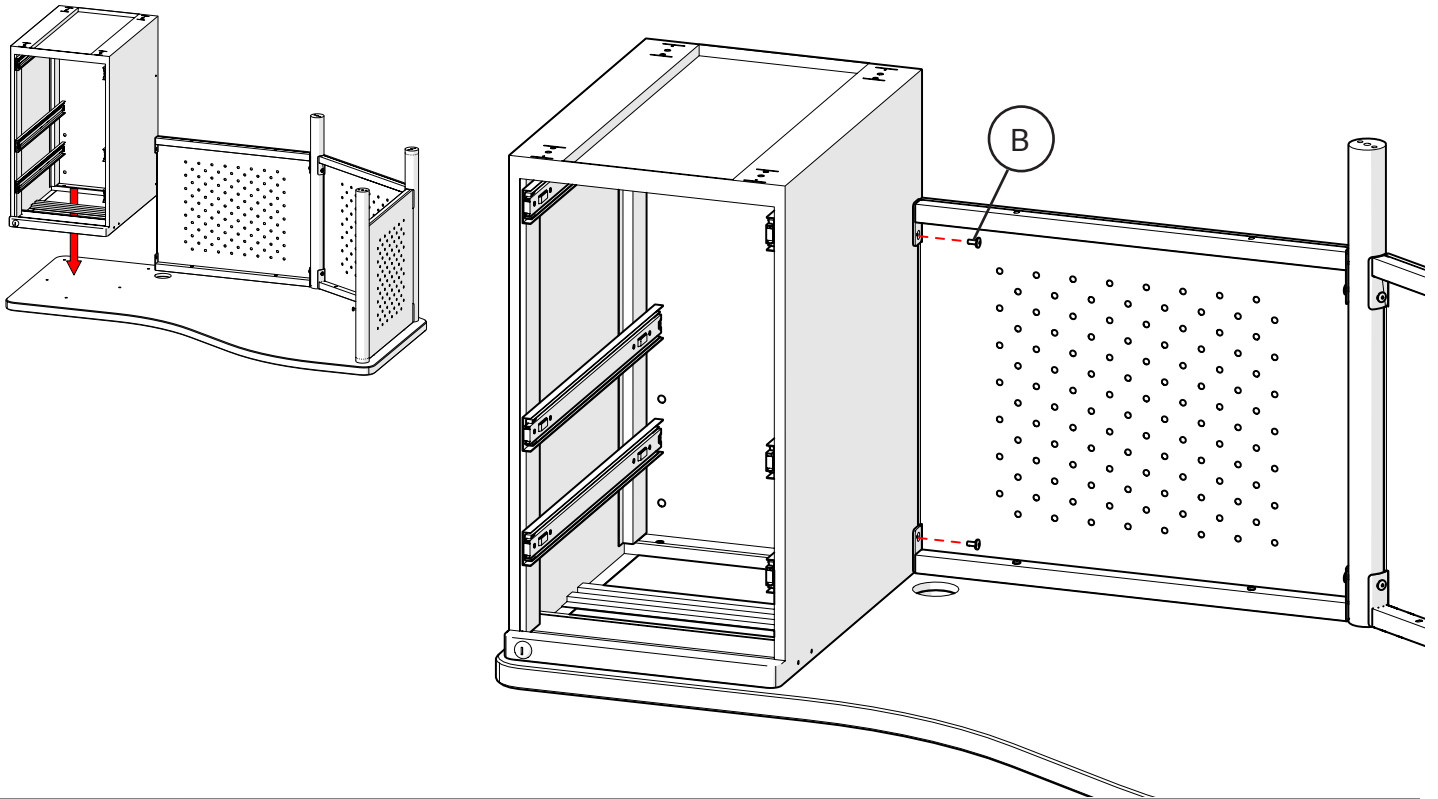

STEP 5

Set Crossbar on top between pedestal and panel. Secure in place with two screws at each end through pedestal side inserts and panel support.

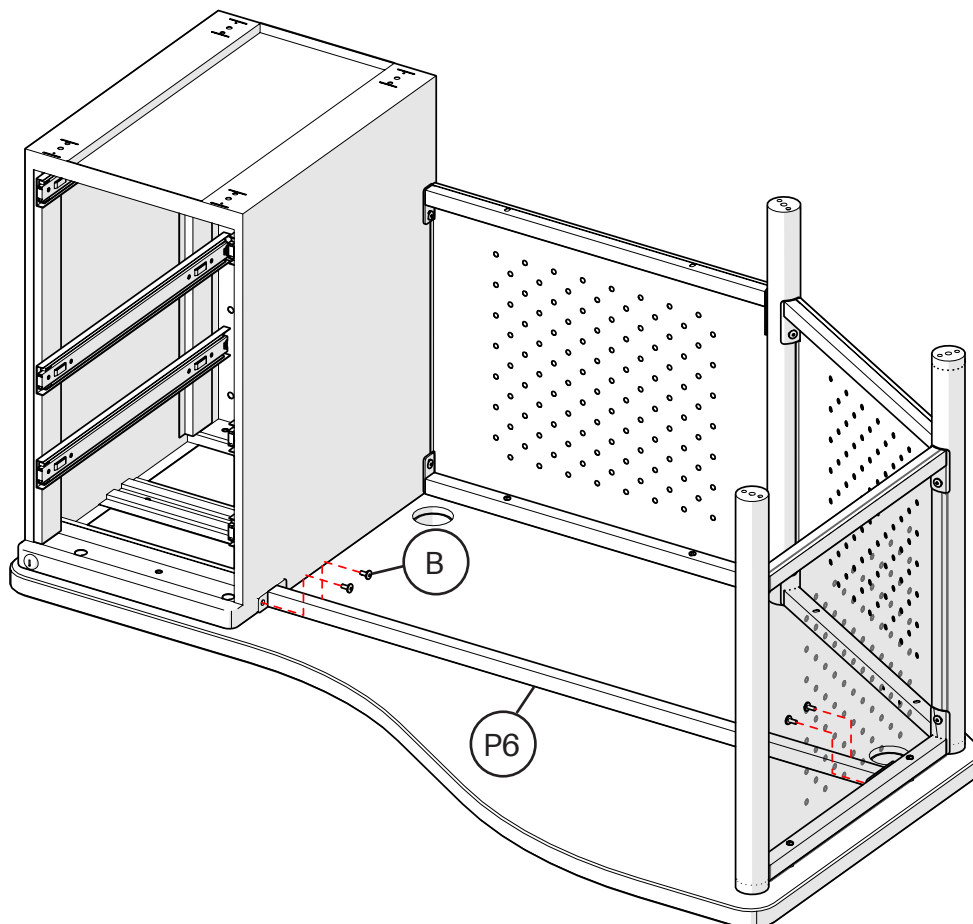

STEP 6

Screw pedestal box into top with five wood screws through holes shown.

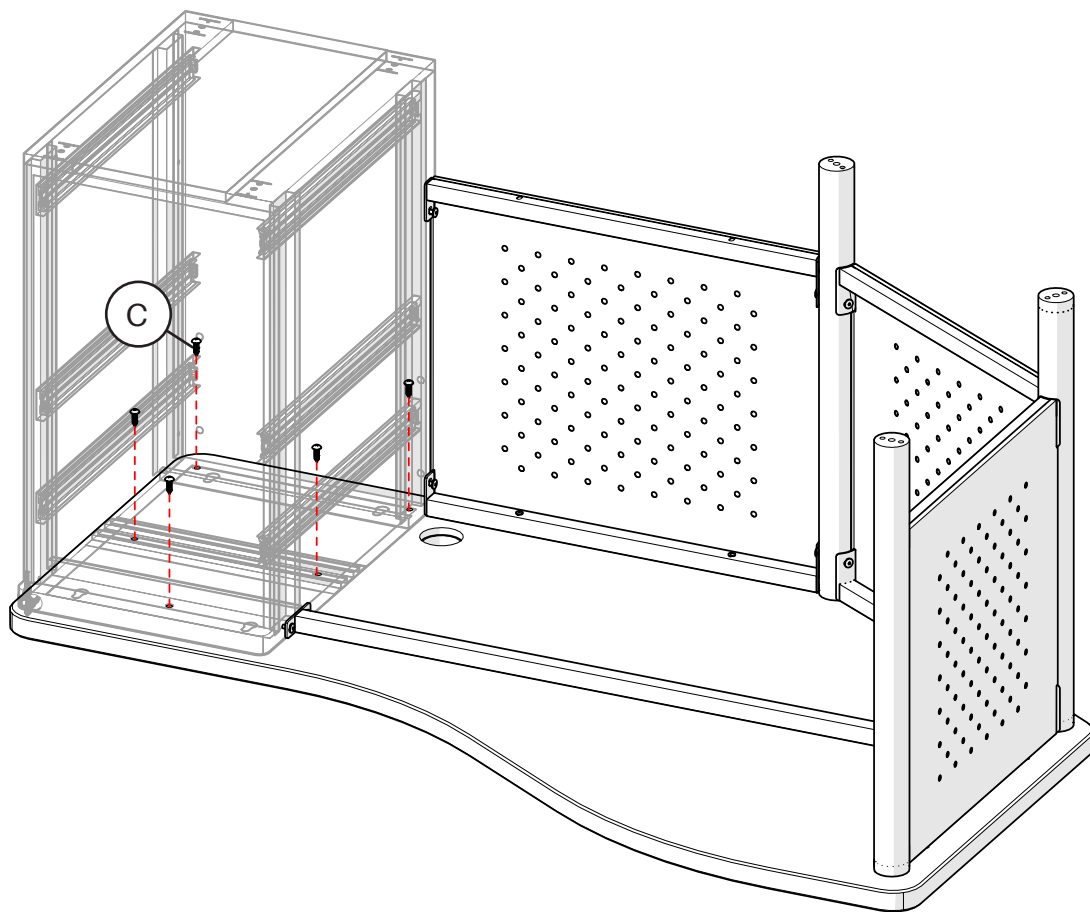

STEP 7

Insert Pedestal Casters by sliding tabs into slots then locking in place with screws. Be sure to place locking casters in front and non-locking in back.

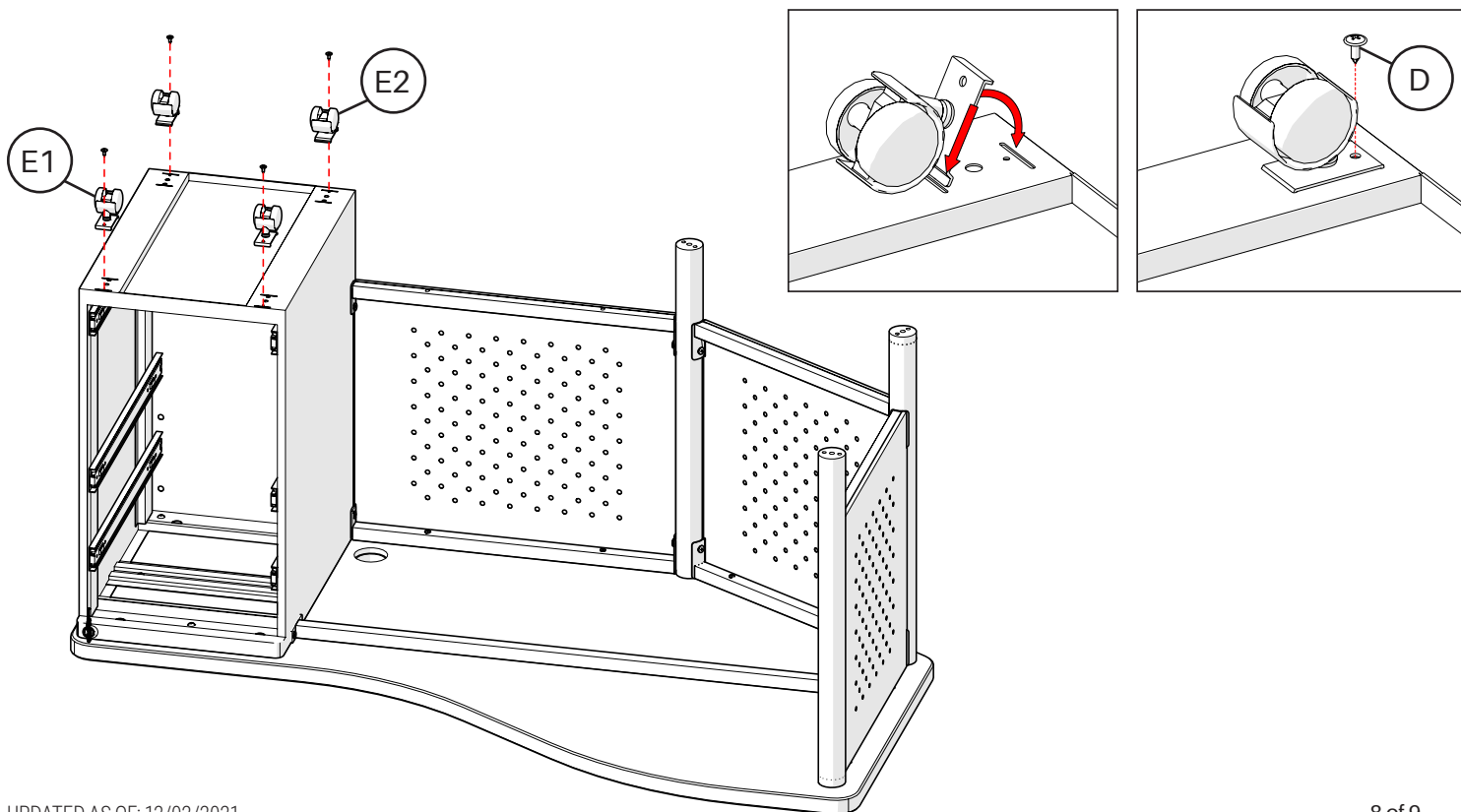

STEP 8

Insert threaded stems on Leg Casters into posts, placing single non-locking caster in the back. Be sure to include a Lock Washer with each and tighten with Caster Wrench.

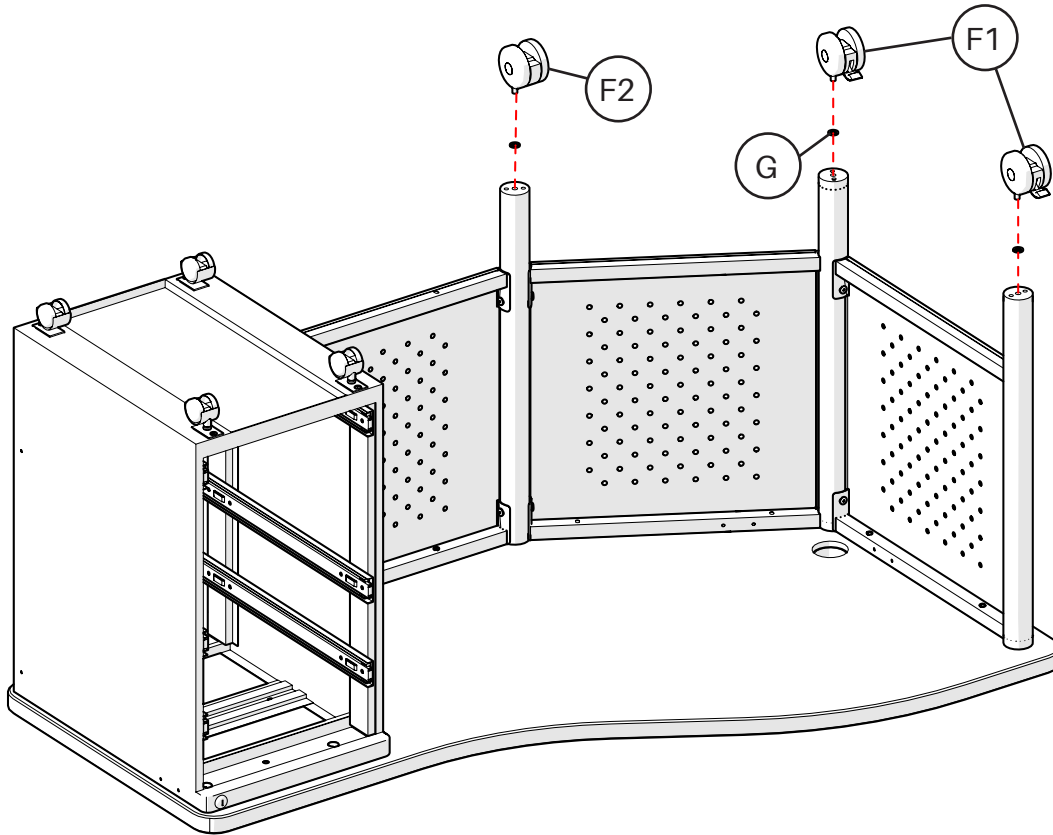

STEP 9

With at least two people, flip desk upright. Insert shelves back into pedestal box and place accessories as desired within shelves. (Optional: Insert Plastic Side Caps and Back Caps into open holes in pedestal.)

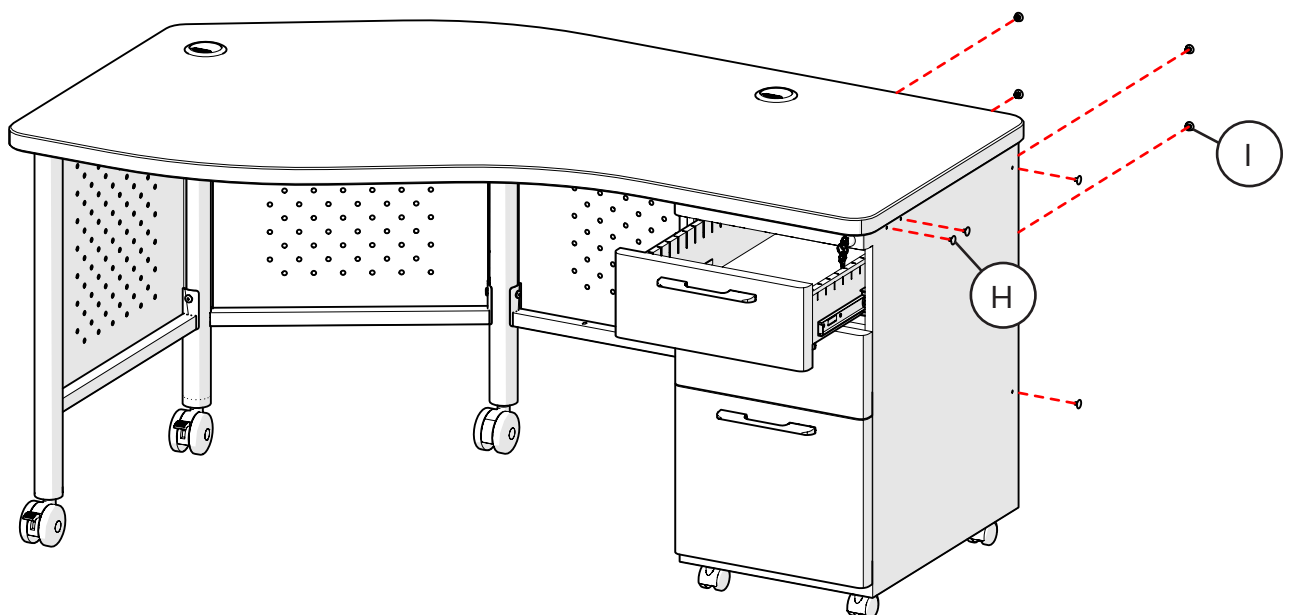

THIS COMPLETES ASSEMBLY INSTRUCTION