

Modular Conference Tables

Model Numbers: 27742, 27743, 27744-XXXX-XX

OVERVIEW

Tables are available in three shapes for multiple arrangement options, making them ideal for any meeting or conference environment.

TABLE TOP

The top is made of 1 1/8" Particleboard Core with 3mm Flat Vinyl T-Mold Edge. The work surface is constructed of 45# particleboard core with high pressure laminate (HPL) top surface and phenolic backer sheet for balanced construction. 1 1/8" 3mm flat vinyl t-mold is secured to the work surface with brad nails along the perimeter.

LEGS

Four black powder-coated steel legs are included for each table that are 3" diameter 1/4" round tubing. Legs are welded to a 12 Ga steel plate with holes for four 3/4" x 0.3" screws that fasten into threaded inserts in underside of table top.

CASTERS

The 3" diameter dual wheel casters screw into leg inserts. Two locking and two non-locking casters come with each table.

COMPLIANCE:

Indoor Advantage Gold certified.

Tested to support up to 300 lbs.

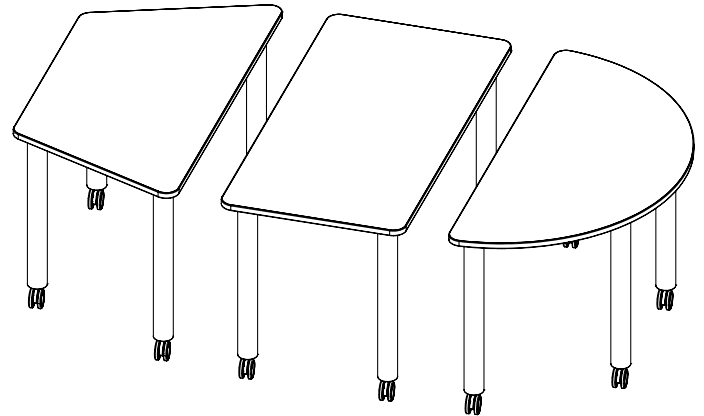

OPTIONS/ACCESSORIES

Pop-Up Grommet Outlet & USB Charger available.

Ganging device available.

LAMINATE OPTIONS:



Amber Cherry Asian Night Castle Oak Fusion Maple Graphite Nebula Gray Elm Gray Nebula Low Line White Board

EDGE BAND COLORS:



Black Platinum Gray Cool Gray Purple Navy Blue Green Yellow Orange Red

FRAME:



Black

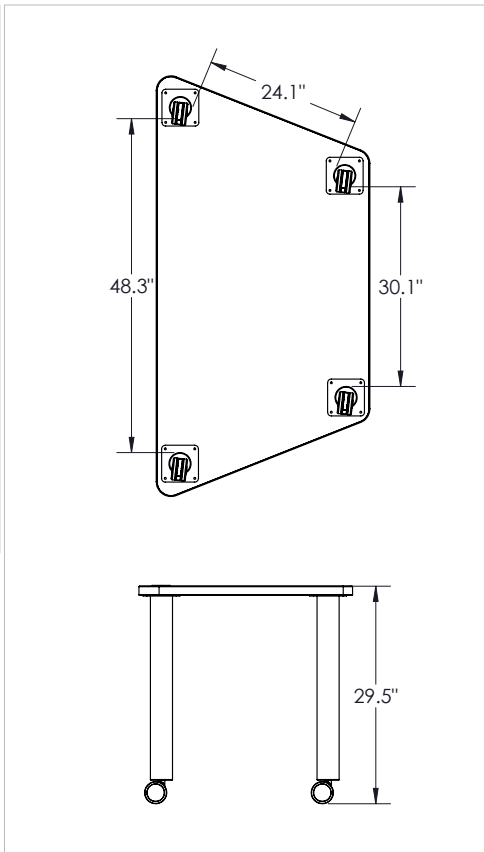
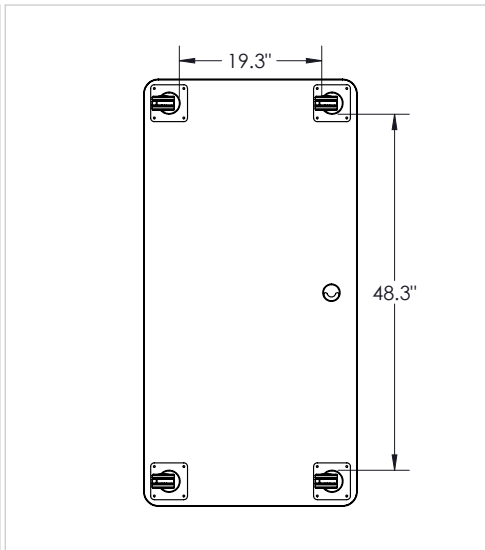
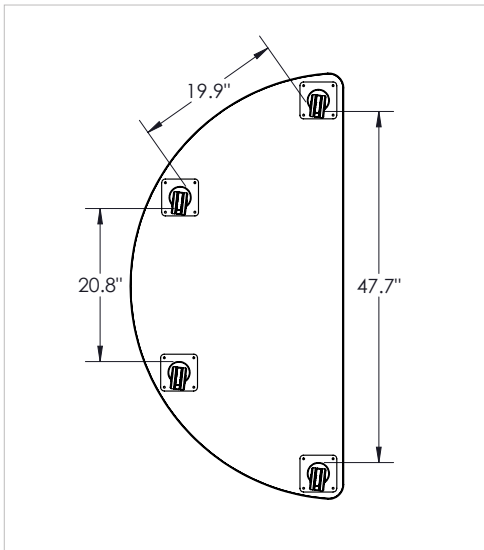
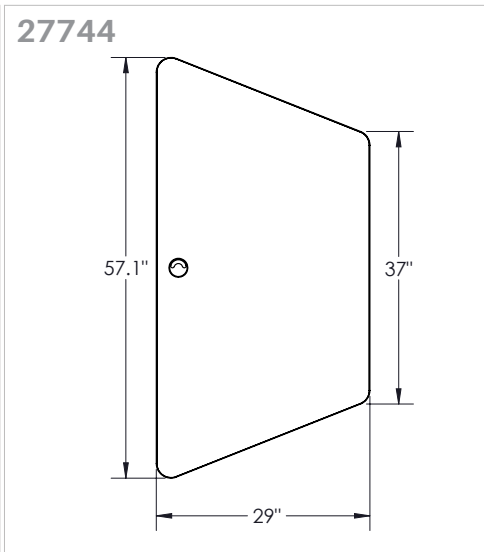
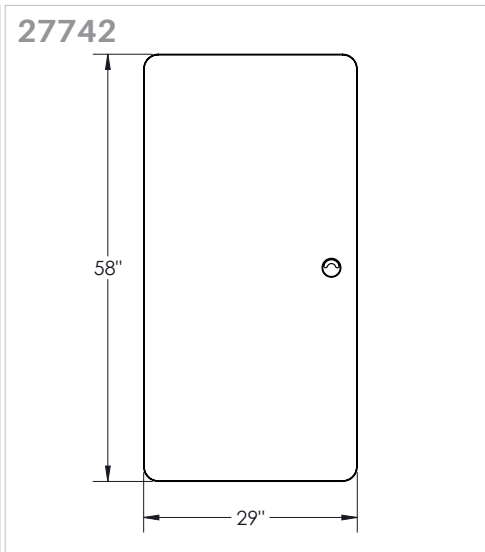
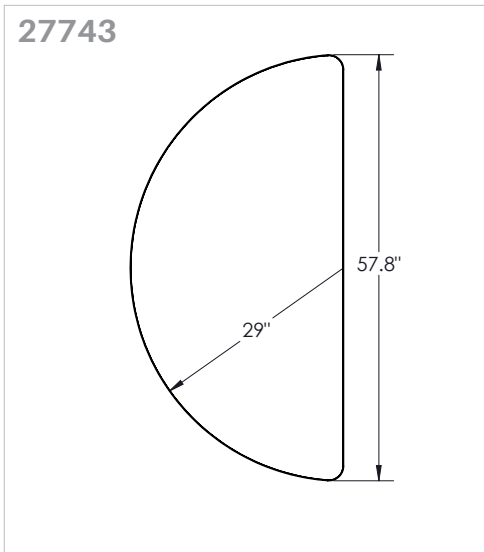

DIMENSIONS

Base Model No.	Description	Dimensions
27742-XXXX-XX	Modular Conference Table (Rectangle)	29.5"H X 58"W X 29"D
27743-XXXX-XX	Modular Conference Table (Half Round)	29.5"H X 58"W X 29"D
27744-XXXX-XX	Modular Conference Table (Trapezoid)	29.5"H X 58"W X 29"D

OPTIONAL ACCESSORIES

Base Model No.	Description	Dimensions
66666	Pop-Up Grommet Outlet & USB Charger	11.6"H x 2.9"W x 2.9"D
66640	Ganging Device for Training Tables (set of 2)	1.6"H x 4.5"W x .3"D