

# BW Clip Real Time

# QUICK REFERENCE GUIDE

2 OR 3 YEAR H<sub>2</sub>S, CO, O<sub>2</sub>, SO<sub>2</sub> SINGLE-GAS DETECTOR

50115903-101 EN B2

BW Clip Real Time is a portable, single-gas detector manufactured by Honeywell. BW Clip Real Time continuously displays the concentration of a specific gas in the ambient environment, and activates an alarm when concentrations exceed alarm setpoints. It is your responsibility to respond appropriately to the alarms.

BW Clip Real Time is a member of the GasAlert family of products. It is compatible with IntelliDoX automatic test and calibration stations, as well as Safety Suite Device Configurator software. For more information, visit the product website at [www.honeywellanalytics.com](http://www.honeywellanalytics.com)

## Safety Information: Read First

### ⚠ WARNING

1. Substitution of components may impair Intrinsic Safety.
2. Honeywell recommends performing a bump test prior to each day's use to confirm sensor response and alarm activation by exposing the detector to a concentration of target gas that exceeds the low alarm set point. Honeywell also recommends performing a bump test if the detector has been subjected to physical impact, liquid immersion, an Over Limit alarm event, custody changes, or anytime the detector's performance is in doubt. Calibrate the detector after a failed bump test. Always bump test and calibrate in a fresh air environment.
3. Detectors in hibernation mode are not functional.

### ⚠ CAUTION

1. Activate the detector before the activation date on the package.
2. This product is a gas detector, not a measurement device.
3. Ensure that the sensor grill is free of dirt, debris, and is not obstructed.
4. Clean the exterior with a soft, damp cloth.
5. For optimal performance, periodically zero the sensor in a normal atmosphere (20.9% v/v O<sub>2</sub>) that is free of hazardous gas.
6. Portable safety gas detectors are life safety devices. Accuracy of ambient gas reading(s) is dependent upon factors such as accuracy of the calibration gas standard used for calibration and frequency of calibration. Honeywell recommends performing a calibration at least once every 180 days (6 months).

## Informations de sécurité – À lire au préalable

### AVERTISSEMENT

1. Le remplacement d'un composant de l'appareil peut compromettre la sécurité intrinsèque du détecteur.
2. Avant chaque utilisation quotidienne, Honeywell recommande d'effectuer un test fonctionnel afin de vérifier la réaction du capteur et l'activation de l'alarme, en exposant le détecteur à une concentration de gaz cible supérieure au seuil d'alarme basse. Honeywell recommande également d'effectuer un test fonctionnel si le détecteur a été soumis à un impact physique, à une immersion dans du liquide, à un événement d'alarme Dépassement de la limite, à des changements d'utilisateur ou chaque fois que les performances du détecteur sont mises en doute. Étalonnez le détecteur après l'échec d'un test fonctionnel. Effectuez toujours un test fonctionnel et étalonnez dans un environnement avec de l'air frais.
3. Détecteurs en mode veille prolongée ne sont pas fonctionnels.

## BW Clip Factory Calibration Certificate

This instrument was factory inspected, tested and calibrated in accordance with the conditions and requirements of our registered Quality System, Operating Standards and Sales Agreements.

### MISE EN GARDE

1. Activez le détecteur avant la date d'activation sur l'emballage.
2. Ce produit est un détecteur de gaz, pas un dispositif de mesure.
3. Veillez à assurer que la grille du capteur est exempt de saleté, les débris, et ne soit pas vobstrué.
4. Nettoyez l'extérieur de l'appareil à l'aide d'un chiffon doux et humide.
5. Pour des performances optimales, zéro périodiquement le capteur dans une atmosphère normale (20,9% v/v O<sub>2</sub>) qui est exempte de gaz dangereux.
6. Les détecteurs portables de gaz de sécurité sont des dispositifs de sécurité des personnes. La précision des valeurs de gaz ambiant dépend de divers facteurs, tels que la précision de la norme de gaz d'étalonnage utilisée pour l'étalonnage et la fréquence d'étalonnage. Honeywell recommande d'effectuer un étalonnage au moins une fois tous les 180 jours (6 mois).

## BW Clip Real Time Factory Calibration Certificate

This instrument was factory inspected, tested and calibrated in accordance with the conditions and requirements of our registered Quality System, Operating Standards and Sales Agreements.

# Honeywell

## Getting Started

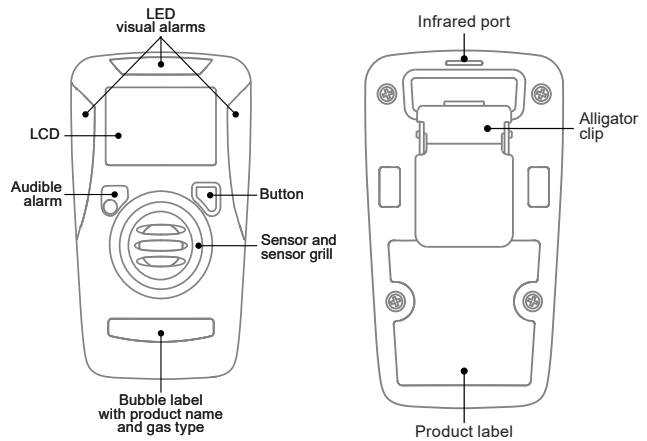

## LCD and Symbols

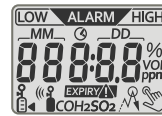

	Button prompt. When this symbol is displayed, press and hold the button until the symbol disappears.
	BW Clip Real Time O <sub>2</sub> models only. Oxygen concentration is measured as percent by volume.
	BW Clip Real Time H <sub>2</sub> S, CO and SO <sub>2</sub> models only. Toxic gas concentration is measured in parts per million.
	Low alarm and high alarm. These symbols are displayed when a gas concentration that exceeds alarm setpoints is detected.
	Non-compliance warning. This symbol is displayed when a diagnostic or compliance test fails; when the operating life countdown reaches 24 hours or less; and for up to 30 days after operating life expiry. It is also displayed when certain notifications are enabled through Safety Suite Device Configurator via an IntelliDoX station.
	Real-time clock. This symbol is displayed when real-time clock is enabled through Safety Suite Device Configurator via an IntelliDoX station.
	End of operating life warning. This symbol is displayed when the operating life countdown reaches 24 hours or less.
	Peak reading. This symbol is displayed when a maximum gas exposure event has occurred within the past 24 hours.
	Bump test reminder. If the detector is configured to display a bump test reminder, this symbol is displayed when a bump test is due.
	X indicates a failed bump test.
	This symbol is displayed when more than 24 hours have elapsed since the last successful zero procedure was performed (O <sub>2</sub> models) or indicates a sensor calibration is due (H <sub>2</sub> S, CO and SO <sub>2</sub> models).
	X indicates a failed calibration (H <sub>2</sub> S, CO and SO <sub>2</sub> models) or a failed zero procedure (O <sub>2</sub> models).
	Operating life remaining in months (MM) or days (DD).

# BW Clip Real Time

2 OR 3 YEAR H<sub>2</sub>S, CO, O<sub>2</sub>, SO<sub>2</sub> SINGLE-GAS DETECTOR

# Honeywell

## Activate a New Detector

1. Move to a normal atmosphere (20.9% v/v O<sub>2</sub>) that is free of hazardous gas.
2. Press and hold the button until a 5 second countdown is displayed, and then continue to hold until the countdown is complete.
3. When the countdown is complete, the LCD and LEDs turn on and then turn off. The detector performs an internal diagnostic test.
4. When the diagnostic test is successful, the alarm setpoints are displayed and the LEDs flash.
5. The sensor stabilization countdown is displayed. During the countdown, the detector vibrates continuously for 20 seconds. The time required to stabilize varies depending on sensor type. When the countdown reaches 0, the LEDs flash and the audible alarm beeps.
6. The detector is in normal operating mode when the gas type and concentration are displayed.

## Normal Operating Mode



When the detector is in normal operating mode, the type of gas detected is permanently displayed. The detected concentration of the gas is displayed until it is disrupted by a button action, gas alarm, or error event.

## Operating Life



When the detector is activated for the first time, the operating life countdown is displayed. Press the pushbutton to display remaining operating life.

## 90 Days or Less Remaining



When the operating life countdown reaches 90 days or less before expiry, the countdown display changes to days. The countdown displays the remaining operating life in days until the countdown reaches 24 hours or less before expiry.

## 24 Hours or Less Remaining



When the operating life countdown reaches 24 hours or less before expiry, the countdown display changes to hours, and the **EXPIRY!** warning and non-compliance symbol are displayed.

## End of Operating Life



When the operating life countdown ends, the detector deactivates and detector safety functions are disabled. It is possible to retrieve event logs for a limited time after expiry. The **EXPIRY!** warning and non-compliance symbol are displayed for up to 30 days after expiry.

## Internal Diagnostic Tests

Activated detectors automatically perform one internal diagnostic test every 24 hours. If the internal diagnostic test fails, the diagnostic fail-safe begins.

## Diagnostic Fail-Safe

1. The **EXPIRY!** warning and non-compliance symbol are displayed.
2. The detector beeps and vibrates.
3. The LEDs flash 2 times per second for 15 seconds.
4. **OFF** or an error code is displayed. The detector is deactivated.

It is possible to retrieve the event logs for a limited time after expiry. If you are unable to retrieve the event logs, contact Honeywell.

## Alarms and Warnings

An alarm is initiated when the sensor is exposed to a gas concentration that exceeds alarm setpoints. The alarm persists until the alarm gas concentration returns to an acceptable range. Battery life decreases rapidly when the detector is in alarm condition.

## Low Alarm



**Audible:** 1 beep per second

**Visual:** 1 flash per second

**Vibration:** 1 vibration per second

## High Alarm



**Audible:** 2 beeps per second

**Visual:** 2 flashes per second

**Vibration:** 2 vibrations per second

## Over-Limit and Under-Limit Alarms



If the gas concentration is beyond the sensor range, **OL** (over-limit) or **-OL** (under-limit) is displayed.

**Audible:** 2 beeps per second

**Visual:** 2 flashes per second

**Vibration:** 2 vibrations per second

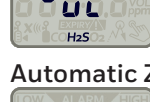

## Automatic Zero Reminder for O<sub>2</sub> Models



For O<sub>2</sub> models only, the **Automatic Zero Reminder** is displayed when more than 24 hours have elapsed since the last successful zero procedure was performed.

## Peak Readings



The peak readings symbol is displayed when the sensor is exposed to a gas concentration that exceeds the alarm setpoints. It is no longer displayed when more than 24 hours have passed since the last alarm, or when a successful bump test is performed via an IntelliDoX station.

## Non-compliance Symbol and LED Indicators

⚠ The non-compliance warning symbol is displayed when:

- an internal diagnostic test fails;
- a bump test, calibration or zero procedure fails;
- a bump test or calibration is due, if enabled;
- the sensor is exposed to a gas concentration that exceeds alarm setpoints, if enabled.

The non-compliance warning symbol is no longer displayed when more than 24 hours have passed since the last alarm, or when a successful bump test or calibration is performed (manual calibration or via an IntelliDoX station). The non-compliance warning symbol is permanently displayed when the service-life countdown reaches 24 hours or less before expiry, and for up to 30 days after expiry.

When **Non-compliance after gas exposure** is enabled through Safety Suite Device Configurator via an IntelliDoX station, the LEDs flash in an alternating pattern when the non-compliance warning symbol is displayed. When the symbol is first displayed, the top LEDs flash. After 30 seconds, the side LEDs flash. After 30 seconds, the pattern repeats until the non-compliance warning symbol is no longer displayed.

**NOTE:** When the detector is bump tested via an IntelliDoX station, an abnormal test result may occur if non-compliance LEDs are flashing. To suspend the flashing for up to 10 minutes, press and release the button. When the flashing stops, insert the detector and perform the test. If the bump test fails, the LEDs resume flashing.

## Recall Events and Settings

**Note:** Alarm setpoints can be manually setup via an IntelliDoX device.

When the detector is in normal operating mode, press the button at any time to scroll through events and settings that are not empty or disabled through Safety Suite Device Configurator via an IntelliDoX station. BW Clip Real Time flashes, vibrates and beeps. While an event or setting is displayed, press the button to scroll to the next available event or setting. If you do not press the button, or if you have reached the last available event or setting, the detector returns to normal operation. Events and settings are displayed in this order:

1. **Peak Reading**, if available, and when a maximum gas exposure event has occurred within the past 24 hours.
2. **Time of Peak Reading**, if Real-time Clock display is enabled.
3. **Operating Life**, the remaining operating life of the detector in months, days or hours.
4. **Low Alarm Setpoint**
5. **High Alarm Setpoint**
6. **Real-time Clock**, if enabled.
7. **Firmware Version**
8. **Next Bump Due**, if enabled.
9. **Next Calibration Due**, if enabled.
10. **Hibernation**, for 2-year H<sub>2</sub>S and CO models only.

# BW Clip Real Time

2 OR 3 YEAR H<sub>2</sub>S, CO, O<sub>2</sub>, SO<sub>2</sub> SINGLE-GAS DETECTOR

# Honeywell

## Zero the Sensor

Over time and through use, the sensor baseline at zero exposure may drift from the manufacturer's baseline. For optimal performance of O<sub>2</sub> models, Honeywell recommends that you zero the O<sub>2</sub> sensor once every 24 hours or when the **Automatic Zero Reminder** is displayed. For all other models, Honeywell recommends that you zero the sensor periodically.

### Zero Procedure.



1. Move to a normal atmosphere (20.9% v/v O<sub>2</sub>) that is free of hazardous gas.
2. Press and hold the button until a 5 second countdown is displayed, and then continue to hold until the countdown is complete.
3. When the countdown is complete, the **Zero** procedure begins and **ZEro** is displayed.
4. When **Zero** is successful, **PASS** and then **CAL ?** is displayed. Press the button to calibrate, or wait for the detector to enter normal operating mode after a 5 second countdown.
5. If **Zero** is not successful, the non-compliance LED flashes. **FAIL** and the non-compliance warning symbol are displayed. Press the button to acknowledge the result and return to normal operation. The non-compliance warning symbol is displayed and the non-compliance LED flashes. Perform the **Zero** procedure again. If the procedure fails again, contact Honeywell.

## Bump Tests

When the detector is configured to display a bump test reminder, the bump test symbol is displayed when a bump test is due. For best results, bump test the detector via an IntelliDoX station. Bump tests performed via an IntelliDoX station are logged as bump tests. Manual bump tests are logged as unsafe gas concentrations.

## Calibration

By default, BW Clip Real Time is configured to use the following calibration gas mixtures:

H <sub>2</sub> S: 20 ppm balance N <sub>2</sub>	CO: 100 ppm balance N <sub>2</sub>	SO <sub>2</sub> : 20 ppm balance N <sub>2</sub>	O <sub>2</sub> : 18.0 % v/v O <sub>2</sub>
--	---------------------------------------	--	--

You can use Safety Suite Device Configurator software via an IntelliDoX station to change a detector's default calibration gas mixtures. If the detector's default calibration mixtures were changed, use the gas mixture values from Safety Suite Device Configurator to calibrate the detector.



1. Move to a normal atmosphere (20.9% v/v O<sub>2</sub>) that is free of hazardous gas.
2. Connect the calibration hose to the gas cylinder and to the intake inlet on the calibration cap.
3. Press and hold the button until a 5 second countdown is displayed, and then continue to hold until the countdown is complete. The zero procedure begins and **ZEro** is displayed. When Zero is successful, **PASS** is displayed.
4. When **CAL ?** is displayed, press the button to begin calibration.
5. Put the calibration cap on the sensor grill.
6. When **GAS ?** is displayed, apply calibration gas for two minutes at a recommended flow rate of 500 ml/min. When calibration is successful, **PASS** is displayed and the detector returns to normal operating mode.

If calibration fails, non-compliance warning symbols are displayed.

Press the pushbutton to acknowledge. Repeat calibration. If it fails again, contact Honeywell.

## Event Logs

The detector stores the last 35 events that occurred, including peak readings, bump tests, calibrations and auto zeros. Each record contains:

- detector serial number, sensor type and life-remaining;
- total number of events that have occurred;
- event type and duration;
- alarm level(s) in ppm or %;
- time elapsed since the alarm occurred in days/hours/minutes;
- duration of the alarm (minutes/seconds).

Use Safety Suite Device Configurator via an IntelliDoX station to transfer event logs from the detector to a computer. When logs are transferred via an IntelliDoX station, the most recent 35 events are transferred.

## Optional Settings

Use Safety Suite Device Configurator via an IntelliDoX station to enable the following optional settings for BW Clip Real Time detectors.

### Non-compliance After Gas Exposure

When **Non-compliance after gas exposure** is enabled, the LEDs flash in an alternating pattern when the sensor is exposed to a gas concentration that exceeds alarm setpoints. When the gas exposure is detected, the top LEDs flash. After 30 seconds, the side LEDs flash. After 30 seconds, the pattern repeats until more than 24 hours have passed since the last alarm, or when a successful bump test is performed via an IntelliDoX station.

### Real-time Clock Display



When **real-time Clock Display** is enabled, you can display the current time by pressing the button to **Recall Events and Settings**, and then continuing to press the button until the time is displayed. Time may be displayed in 12-hour or 24-hour clock format.

## Hibernation

**Hibernation** is a factory installed feature that is available for 24-month H<sub>2</sub>S and CO detectors. When **Hibernation** is activated, the operating life countdown is suspended. Use **Hibernation** to deactivate the detector for 7 days or longer, up to a maximum of 12 months. When **Hibernation** is activated, all detector safety functions are disabled.

### Activate Hibernation via BW Clip Real Time Hibernation Case



1. Have ready a BW Clip Hibernation Case. To purchase a Case, contact Honeywell or an authorized distributor.
2. Move to a normal atmosphere (20.9% v/v O<sub>2</sub>) that is free of hazardous gas.
3. Verify that the detector is in normal operating mode.
4. Press the button to **Recall Events and Settings**, and then continue to press the button until **Hib** is displayed.
5. While **Hib** is displayed, press the button until a 5 second countdown is displayed. When the countdown is complete, the 20-second **Hibernation** counter is displayed.
6. While the **Hibernation** counter is displayed, place the detector into a BW Clip Real Time Hibernation Case and then close the case firmly. The detector enters **Hibernation** mode. All detector safety functions are disabled.
7. To reactivate the detector, open the case and remove the detector.

### Activate Hibernation through Safety Suite Device Configurator via IntelliDoX

1. Use Safety Suite Device Configurator to activate **Hibernation on Insertion** via an IntelliDoX station, and then insert the detector in the configured station. The detector event logs are retrieved, and the detector enters **Hibernation** mode. All safety functions are disabled, and the detector may be removed from the IntelliDoX station.
2. To reactivate the detector, press and hold the button until a 5 second countdown is displayed, and then continue to hold until the LCD and LEDs turn on and off. The detector performs a self-diagnostic test. When the test is successful, the type of gas detected and the remaining operating life are displayed. The detector is in normal operating mode.
3. For more information, refer to the operator manuals for the IntelliDoX station and Safety Suite Device Configurator software.

### About this Publication

This publication is an operator guide for BW Clip Real Time portable single-gas detectors manufactured by Honeywell. It is intended for use with the following models:

- 24- and 36-month H<sub>2</sub>S and CO Detectors
- 24-month O<sub>2</sub> detector
- 24-month SO<sub>2</sub> detector

### Copyright, Notice, Trademarks

While this information is presented in good faith and believed to be accurate, Honeywell disclaims the implied warranties of merchantability and fitness for a particular purpose and makes no express warranties except as may be stated in its written agreement with and for its customers.

In no event is Honeywell liable to anyone for any indirect, special or consequential damages. The content in this document is subject to change.

