



# DLM112SD

*USER'S MANUAL*



## LIGHT METER WITH DATA LOGGING SD CARD

*Please read this manual carefully and thoroughly before using this product.*

# TABLE OF CONTENTS

|   |                |
|---|----------------|
| <b>Introduction</b> .....   | <b>3</b>       |
| <b>Key Features</b> .....   | <b>4</b>       |
| <b>Operating Instructions</b> .....                                   | <b>4 – 11</b>  |
| <b>What's in the case</b> .....                                       | <b>4 – 5</b>   |
| <b>Setup</b> .....  | <b>6 – 8</b>   |
| <b>Normal Operation</b> .....   | <b>8 – 9</b>   |
| <b>Holding and Storing Measurements</b> .....                         | <b>9</b>       |
| <b>Automatic vs. Manual Datalogging</b> .....                         | <b>9 – 10</b>  |
| <b>Transferring Data from the SD Card<br/>    to a Computer</b> ..... | <b>10 – 11</b> |
| <b>Specifications</b> .....   | <b>12</b>      |
| <b>Maintenance &amp; Troubleshooting Tips</b> .....                   | <b>13</b>      |
| <b>Optional Accessories</b> .....                                     | <b>13</b>      |
| <b>Warranty Information</b> .....                                     | <b>13</b>      |
| <b>Return for Repair Policy</b> .....                                 | <b>14</b>      |

---

## INTRODUCTION

Thank you for purchasing General Tools & Instruments' DLM112SD UV Light Meter with Datalogging SD Card. Please read this user's manual carefully and thoroughly before using the instrument.

The DLM112SD is a general-purpose handheld instrument suitable for measuring the intensity of light in commercial, industrial and consumer settings. Applications include photography, videography, construction, engineering and surveillance.

This light meter measures light intensity using either of two units: lux or foot-candles. The lux is the standard international unit of illuminance, or how much luminous flux is spread over a given area. One can think of luminous flux as a measure of the total "amount" of visible light present, and illuminance as a measure of the intensity of illumination on a surface. A given amount of light will illuminate a surface more dimly if it is spread over a larger area, so illuminance is inversely proportional to area.

The standard international unit of luminous flux is the lumen, and one lux is equal to one lumen/m<sup>2</sup>. For perspective on lux readings from the natural world, consider that a moonless clear night sky has an illuminance of about 0.002 lux, while direct sunlight has an illuminance of 30,000 to 130,000 lux.

The footcandle (or lumen per square foot) is a non-standard unit of illuminance. Like the Btu, it is mainly in common use only in the U.S., particularly in construction-related engineering and in building codes. Because lux and footcandles are different units of the same quantity, it is perfectly valid to convert footcandles to lux and vice versa. One footcandle (ft-cd) = 10.764 lux.

The DLM112SD has the performance and features needed to satisfy the most demanding aspects of the above applications. It also has the ability to measure surface temperature, using an optional Type K of Type thermocouple. A light probe comes standard with the instrument.

Because it is microprocessor-based, the DLM112SD can make full use of the portability, reliability and large storage capacities that SD memory cards offer. Measurements of light intensity or temperature can be made automatically at any of 11 sampling rates between one second and one hour. After time-stamping and storing the measurements on an SD card plugged into the instrument (a process called datalogging), the user can remove the card and transfer the measurements to a laptop or desktop computer either directly or via a USB card reader.

The DLM112SD has a backlit 2-1/2 in. diagonal display and is powered by six "AA" Alkaline batteries or an optional 9-VDC AC adapter.

---

## KEY FEATURES

- Includes light probe
- Measures light intensity within three automatically switched full-scale ranges: 2,000 lux, 20,000 lux and 100,000 lux (200 ft-cd, 2,000 ft-cd and 10,000 ft-cd)
- Selectable lux or foot-candle unit
- Displays maximum and minimum readings
- Performs real-time automatic datalogging at sampling time settable from 1 second to 1 hour
- Also supports manual logging and changing of card storage location
- Accepts SD memory cards of up to 16 GB capacity
- Big (2.5 in. diagonal) front-panel green backlit LCD is easy to read
- Auto power off function
- Powered by six “AA” batteries or optional 9V AC/DC adapter

---

## OPERATING INSTRUCTIONS

### ***WHAT'S IN THE CASE***

The DLM112SD comes fully assembled in a carrying case along with a light probe with a protective cover, a 2 GB SD memory card and this user's manual.

Optional accessories available from General Tools & Instruments include Type K and Type J thermocouples and a 9VDC adapter for a 110V power supply. See the Replacement Parts & Optional Accessories section of this manual for more details.

Figure 1 shows all of the controls and indicators on the front, back, top, bottom and right side of the DLM112SD. It also shows (at right) the main components of the supplied light probe. Familiarize yourself with their positions and functions before moving on to the setup procedure.

**Fig. 1**

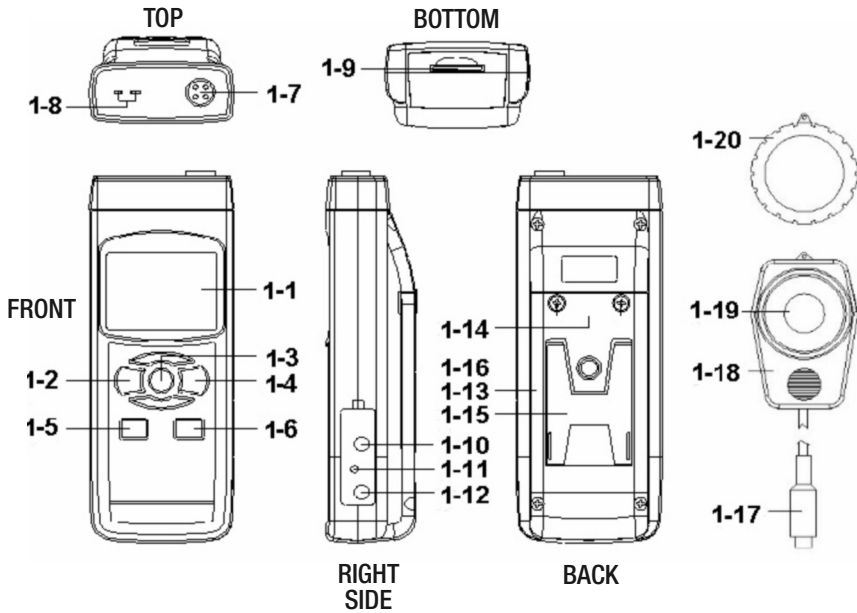

- |  |                                       |
|--|---------------------------------------|
| 1-1 Liquid-crystal display                                 | 1-11 RESET Button                     |
| 1-2 POWER/ESC button                                       | 1-12 Socket for 9VDC AC adapter       |
| 1-3 FUNC./HOLD/NEXT button                                 | 1-13 Battery compartment cover        |
| 1-4 REC/ENTER button                                       | 1-14 Battery compartment cover screws |
| 1-5 SET ▼ button   | 1-15 Kickstand                        |
| 1-6 LOGGER ▲ button  | 1-16 Tripod attachment nut            |
| 1-7 Socket for light probe                                 | 1-17 Light probe plug                 |
| 1-8 Socket for Type-K or -J thermocouple temperature probe | 1-18 Light sensor housing             |
| 1-9 SD card socket   | 1-19 Light sensor                     |
| 1-10 RS232 output jack                                     | 1-20 Light sensor cap                 |

**1. The DLM112SD's controls and indicators and other physical features**

## SETUP

**1. Choose the power source.** Before using the DLM112SD, be sure it is powered by fresh batteries or an optional 9VDC AC adapter plugged into the bottom jack on its right side (callout 1-12).

To remove the battery compartment cover, remove the two screws holding it in place (callout 1-14). Then install six “AA” batteries in the correct orientation, using the polarity marks on the inside of the compartment as a guide. Replace the cover by replacing the two screws.

**2. Install an SD card.** To prepare for setup, also install the supplied 2 GB SD memory card or another card with a capacity from 1 GB to 16 GB in the socket on the bottom of the DLM112SD (callout 1-9). When installing the card, make sure its gold contacts are facing front and push the card into the socket until you hear a click. To remove the card, push it in until you hear a click and the card pops out.

Now power on the instrument by pressing the POWER/ESC button (callout 1-2) to generate a short beep. (To power off the DLM112SD, press the POWER/ESC button and hold it until the instrument responds with a long beep.)

When the DLM112SD powers on, a series of transient startup screens will briefly appear. Once the display has stabilized, perform the following series of eight setup steps in the order presented.

**3. Set the date and time.** Press the SET ▼ button (callout 1-5) and hold it for at least five seconds, until the word “dAtE” appears in the center of the display, along with the flashing value “00.00.00” at the lower left, above “yy.mm.dd”.

(If you press buttons too slowly in setup mode, the screen will revert to the normal display. To return to the setup sequence, press and hold the SET ▼ button again. To move ahead to the next field in the sequence or to the next parameter, press the FUNC./HOLD/NEXT button (callout 1-3).)

First set the current year by pressing the SET ▼ or LOGGER ▲ button repeatedly until the correct value appears above “yy”. Press the REC/ENTER button to store the setting. The next screen that appears will have the value above “mm” flashing. Use the SET ▼ or LOGGER ▲ button to navigate to the current month and press the REC/ENTER button to store the setting. When the next screen flashes the value above “dd”, again use the SET ▼ or LOGGER ▲ button to navigate to the current day and press the REC/ENTER button to store the setting.

Once you have set the date, the display will prompt you to set the hour, minute and second of the current time. Again use the SET ▼ or LOGGER ▲ buttons to navigate to the correct values, and the REC/ENTER button to store the settings.

- 4. Choose a decimal point or comma** to represent the decimal division between integers and fractions (for example, American-style 20.88 vs. European-style 20,88). Once you have finished setting the time, the display will show the word “bASIC” above the phrase “dEC”. Press the SET ▼ button to make “bASIC” (American style) or “Euro” appear in the upper display, as desired. Press the REC/ENTER button to store the selection.
- 5. Enable or disable auto power off.** Once the format of decimal divisions has been set and stored, the display will show the word “yES” over the term “PoFF”. Press the SET ▼ button until the desired automatic power off management scheme (“yES” for enable; “no” for disable) is displayed. Press the REC/ENTER button to store the selection. If enabled, the power off function shuts off the DLM112SD after a period of inactivity of ten minutes
- 6. Enable or disable the beeper.** Once the desired power management function has been set and stored, the display will show the word “yES” over the word “bEEP”. Press the SET ▼ button until the desired setting (“yES” or “no”) is displayed, and then press the REC/ENTER button to store the selection.
- 7. Select the thermocouple type.** Once the beeper has been enabled or disabled, the display will show the word “Set” over the word “tYPE”. Press the SET ▼ button until the desired setting (“K” or “J”, for a Type K or Type J thermocouple) appears on the right side of the display. Then press the REC/ENTER button to store the selection.
- 8. Select the temperature unit.** Once the thermocouple type has been set and stored, the display will show the term “t-CF”. Press the SET ▼ button until the desired setting (“F” or “C”, for Fahrenheit or Celsius units) appears on the right side of the display. Then press the REC/ENTER button to store the selection.
- 9. Set the datalogging sampling time.** Once the temperature unit has been set and stored, the display will show a value above the letters “SP-t”. Press the SET ▼ button or the LOGGER ▲ button to decrease or increase the value until the desired sampling time appears above “SP-t”. The options are 0, 1, 2, 5, 10, 30, 60, 120, 300, 600, 1800 and 3600 seconds (0 seconds to 1 hour).
- 10. Format the SD card.** Once the sampling time has been set and stored, the word “no” or “yES” will be displayed over the term “Sd-F”. Press the SET ▼ button to make a selection.

Choose “yES” whenever a new SD card is being used, or when a used card is being repurposed (from use with another SD card instrument or a camera, for example) and all data on it is to be erased. Choose “no” to preserve any data on a card previously used with this instrument.

If you choose “yES”, after you press the REC/ENTER button the instrument will prompt you to confirm that decision by displaying the term “Ent” below “yES” and sounding three beeps. To confirm that you want to begin the erasure/formatting procedure, press the REC/ENTER. “Ent” will then flash several times and the instrument will sound another three beeps to confirm that the SD card has been erased and formatted.

Once the SD card has been formatted (or not), the display will then either return to the first of the six steps in the setup sequence—setting the current date and time—or show the term “ESC”. If “ESC” appears, press the POWER/ESC button to exit the setup procedure and enter normal operating mode.

## **NORMAL OPERATION**

The DLM112SD can measure and store two different kinds of values:

- The intensity of light, in lux or footcandles. The unit lux is analogous to the radiometric unit mW/cm<sup>2</sup>, but with the power at each wavelength weighted according to the luminosity function, a standardized model of human visual brightness perception. One footcandle = 10.764 lux.
- Temperature (in oF or oC), as sensed by a Type K or Type J thermocouple.

Pressing and holding the FUNC./HOLD/NEXT button will bring up, in order, two blank five-digit displays above the terms “LigHt” and “tP” (for temperature). Each display also automatically shows the correct unit for the parameter.

- 1. To choose the measurement function**, release the FUNC./HOLD/NEXT button when the desired parameter appears. This becomes the instrument’s default measurement function until you change it.
- 2. To measure the intensity of light**, plug the light probe (with its sensor cap on) into the socket at the top of the DLM112SD (callout 1-7) and use the FUNC.HOLD/NEXT button to select light measurement mode. If the display shows a value other than zero, press the LOGGER ▲ button and hold it for at least three seconds until you hear a beep. Then remove the cap from the probe.

Holding the sensor housing, point the sensor directly at the light source whose intensity you wish to measure. The display will indicate the intensity in units of lux. To change the unit of measurement to footcandles (Ft-cd), press the REC/ENTER button. The last unit selected becomes the default unit.

- 3. To measure temperature**, first make sure that the light probe is not plugged into the instrument. Then use the FUNC.HOLD/NEXT button to select temperature measurement mode and plug either a Type K or Type J thermocouple into the socket (callout 1-8) on the top of the DLM112SD. The display will read out the sensed temperature in degrees F or C, depending on the setting chosen during setup.



To change the unit of measurement, or to configure the instrument for use with a Type J thermocouple probe, press the SET ▼ button to reenter setup mode and perform Step 7 or 8 of the procedure. Along with the measured value, the display also shows the type of thermocouple the DLM112SD is configured for.

Whenever the DLM112SD is in measurement mode, you can turn off the backlight (which is on by default) by briefly pressing (but not holding) the POWER/ESC button. To reactivate the backlight, briefly press the button again.

Whenever the instrument is in measurement mode, you also can check the current date and time by briefly pressing the SET ▼ button. Doing so causes both values to appear briefly at the lower left of the display.

## ***HOLDING AND STORING MEASUREMENTS***

**4. To hold a measured value of light intensity or temperature**, press the FUNC./HOLD/NEXT button during the measurement. Doing so will cause the word “HOLD” to appear at the top of the display. Pressing the FUNC./HOLD/NEXT button again releases the hold.

**5. To record and recall readings**, press the REC/ENTER button while making measurements. This will make the term “REC” appear at the top of the display. Pressing the REC/ENTER button again, briefly, will make the term “MAX” appear to the right of “REC” and switch the display to the maximum value stored in memory during the last recording session. Pressing the REC/ENTER button again, briefly, will make the term “MIN” appear to the right of “REC” and switch the display to the minimum value stored during the last session.

**6. To exit recording mode**, press and hold the REC/ENTER button for at least three seconds, until the term “REC” disappears from the top line of the display. The display will then revert to showing the current reading.

## ***AUTOMATIC VS. MANUAL DATALOGGING***

The DLM112SD can automatically log data using any of 11 sampling times from 1 second to 1 hour. To view the sampling time for which the instrument was set up, press the LOGGER ▲ button once. To change the datalogging sampling time, perform Step 9 of the setup procedure.

**7. To start automatic datalogging**, press the REC/ENTER button once. The top line of the display will then show the term “REC”. Pressing the LOGGER ▲ button at this point will make REC flash and add the flashing term “LOGGER” at the top right of the display. This indicates that the instrument is currently storing measured values and their time stamps in memory.

**8. To pause automatic datalogging**, press the LOGGER ▲ button once; this action makes the flashing term LOGGER disappear from the top right of the display and changes the term “REC” from flashing to constant. Pressing the LOGGER ▲ button again resumes automatic datalogging.

**9. To end automatic datalogging**, press the REC/ENTER button and hold it for at least two seconds. This action causes the “REC” message to disappear.

**10. To log data manually**, set the sampling time to zero Step 9 of the setup procedure. Then press the REC/ENTER button once. The display will show the term “REC” on the top line, a value in the middle, and below it the letter “P” on the left and a number from 1 to 99 on the same line to the right.

The number indicates the position on the SD card that will be used to store manually logged data.

Now press the LOGGER ▲ button. This will cause the beeper to sound and the term “LOGGER” to briefly appear at the upper right of the display. As in automatic datalogging mode, in this mode the instrument is storing measurements and their time stamps on the SD card.

In manual datalogging mode, however, measurements are being stored continuously (with a sampling time of zero), and their locations on the card can be changed.

**11. To change the storage location of manually logged data**, press the SET ▼ button once; this causes the “P” to disappear from the left side of the display and the value on its line to begin flashing. Once the flashing begins, you can use the SET ▼ and LOGGER ▲ buttons to change the flashing value to any number between 1 and 99. Once you have chosen the storage location, press the REC/ENTER button to save the setting. This causes the value to stop flashing and the “P” to return.

**12. To end manual datalogging**, press the REC/ENTER button and hold it for at least three seconds. This action causes the “REC” message to disappear from the top line of the display.

## ***TRANSFERRING DATA FROM THE SD CARD TO A COMPUTER***

After automatic or manual datalogging of measurements, remove the SD card from the DLM112SD and plug it into your computer either directly (if it has an SD card slot) or through an SD card reader.

Because the files containing time-stamped data logs have the file extension .xls, they open in Microsoft’s Excel application. Figures 2 and 3 show two kinds of Excel presentations: a data-only screen and a graphics-only screen.

|    | A     | B        | C        | D     | E    | F     | G    | H | I | J | K |
|----|-------|----------|----------|-------|------|-------|------|---|---|---|---|
| 1  | Place | Date     | Time     | Value | Unit | Value | Unit |   |   |   |   |
| 2  | 1     | 2009/6/8 | 15:14:54 | 663   | LUX  |       |      |   |   |   |   |
| 3  | 2     | 2009/6/8 | 15:14:55 | 666   | LUX  |       |      |   |   |   |   |
| 4  | 3     | 2009/6/8 | 15:14:56 | 663   | LUX  |       |      |   |   |   |   |
| 5  | 4     | 2009/6/8 | 15:14:57 | 663   | LUX  |       |      |   |   |   |   |
| 6  | 5     | 2009/6/8 | 15:14:58 | 666   | LUX  |       |      |   |   |   |   |
| 7  | 6     | 2009/6/8 | 15:14:59 | 659   | LUX  |       |      |   |   |   |   |
| 8  | 7     | 2009/6/8 | 15:15:00 | 664   | LUX  |       |      |   |   |   |   |
| 9  | 8     | 2009/6/8 | 15:15:01 | 664   | LUX  |       |      |   |   |   |   |
| 10 | 9     | 2009/6/8 | 15:15:02 | 664   | LUX  |       |      |   |   |   |   |
| 11 | 10    | 2009/6/8 | 15:15:03 | 664   | LUX  |       |      |   |   |   |   |
| 12 | 11    | 2009/6/8 | 15:15:04 | 664   | LUX  |       |      |   |   |   |   |
| 13 | 12    | 2009/6/8 | 15:15:05 | 667   | LUX  |       |      |   |   |   |   |
| 14 | 13    | 2009/6/8 | 15:15:06 | 674   | LUX  |       |      |   |   |   |   |
| 15 | 14    | 2009/6/8 | 15:15:07 | 674   | LUX  |       |      |   |   |   |   |
| 16 | 15    | 2009/6/8 | 15:15:08 | 674   | LUX  |       |      |   |   |   |   |
| 17 | 16    | 2009/6/8 | 15:15:09 | 674   | LUX  |       |      |   |   |   |   |
| 18 | 17    | 2009/6/8 | 15:15:10 | 155   | LUX  |       |      |   |   |   |   |
| 19 | 18    | 2009/6/8 | 15:15:11 | 1038  | LUX  |       |      |   |   |   |   |
| 20 | 19    | 2009/6/8 | 15:15:12 | 2030  | LUX  |       |      |   |   |   |   |
| 21 | 20    | 2009/6/8 | 15:15:13 | 1250  | LUX  |       |      |   |   |   |   |
| 22 | 21    | 2009/6/8 | 15:15:14 | 1088  | LUX  |       |      |   |   |   |   |
| 23 | 22    | 2009/6/8 | 15:15:15 | 874   | LUX  |       |      |   |   |   |   |
| 24 | 23    | 2009/6/8 | 15:15:16 | 1007  | LUX  |       |      |   |   |   |   |

**Fig. 2. Typical Excel data-only screen**

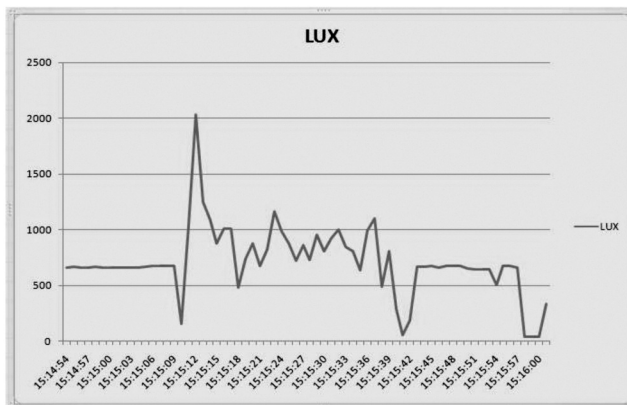

**Fig. 3. Typical Excel graphics-only screen**

---

## SPECIFICATIONS

---

|                             |  |
|-----------------------------|--|
| Embedded microcontroller    | Custom one-chip LSI device   |
| Display type                | Liquid-crystal with green backlight  |
| Display size                | 2.05 x 1.5 in. (52 x 38 mm)  |
| Full-scale ranges           | 0 to 1,999 lux; 1,800 to 19,990 lux;<br>(automatically switched) 18,000 to 99,900 lux<br>(0 to 186 ft-cd; 167 to 1,860 ft-cd;<br>1,670 to 9,290.7 ft-cd)   |
| Measurement accuracy        | $\pm 4\%$ of full-scale reading + 2 digits for all lux readings<br>and ft-cd readings at 200 ft-cd full-scale (f.s.);<br>$\pm 4\%$ of f.s. reading + 2 ft-cd at 2,000 ft-cd f.s.;<br>$\pm 4\%$ of f.s. reading + 20 ft-cd at 20,000 ft-cd f.s. |
| Measurement resolution      | 1 lux at 2,000 lux f.s.;<br>10 lux at 20,000 lux f.s.;<br>100 lux at 100,000 lux f.s.;<br>0.1 ft-cd at 200 ft-cd f.s.;<br>1 ft-cd at 2,000 ft-cd f.s.;<br>10 ft-cd at 10,000 ft-cd f.s.  |
| Stored readings             | Maximum, minimum   |
| Datalogging sampling times  | 1 second to 1 hour (automatic mode)  |
| SD card capacity            | 1 GB to 16 GB  |
| Settable parameters         | Date, time, auto power off, beep sound, temperature<br>unit (oF or oC), sampling time, thermocouple type<br>(K or J), decimal point or comma   |
| Operating temperature       | 32° to 122oF (0° to 50oC)  |
| Operating relative humidity | 0 to 85%   |
| Power source                | 6 Alkaline “AA” batteries or optional<br>9-VDC AC adapter  |
| Power consumption           | 6.5 mADC (normal operation, with backlight off and<br>SD card not saving data; 30 mADC with backlight on)  |
| Dimensions of meter         | 6.97 x 2.68 x 1.77 in. (177 x 68 x 45 mm)  |
| Weight of meter             | 1.08 lb. (489g)  |

---

---

## MAINTENANCE & TROUBLESHOOTING TIPS

Keep the light probe clean and its sensor under the protective cap when not in use.

When the icon  appears in the left corner of the display, it's time to replace the six "AA" batteries that power the instrument (although measurements will remain valid for several hours after the low-battery indicator first appears). Replacing the batteries requires removing the two screws that hold the battery compartment cover in place, as explained earlier. After inserting fresh batteries in the correct orientation, tighten the screws to secure the cover.

If the meter "freezes" (like a computer) and buttons become unresponsive, try resetting the instrument by pushing the RESET button on its right side (callout 1-11 of Fig. 1) with the end of a paper clip.

Remove the batteries when storing this product for an extended period of time.

Do not drop or disassemble the instrument or immerse it in water.

---

## REPLACEMENT PARTS & OPTIONAL ACCESSORIES

- Type K or Type J thermocouple (optional)
- 9-VDC adapter for 110VAC power supply (optional)
- Spare light probe

---

## WARRANTY INFORMATION

General Tools & Instruments' (General's) DLM112SD UV Light Meter with Datalogging SD Card is warranted to the original purchaser to be free from defects in material and workmanship. Subject to certain restrictions, General will repair or replace this instrument if, after examination, the company determines it to be defective in material or workmanship for a period of one year.

This warranty does not apply to damages that General determines to be from an attempted repair by non-authorized personnel or misuse, alterations, normal wear and tear, or accidental damage. The defective unit must be returned to General Tools & Instruments or to a General-authorized service center, freight prepaid and insured.

Acceptance of the exclusive repair and replacement remedies described herein is a condition of the contract for purchase of this product. In no event shall General be liable for any incidental, special, consequential or punitive damages, or for any cost, attorneys' fees, expenses, or losses alleged to be a consequence of any damage due to failure of, or defect in any product including, but not limited to, any claims for loss of profits.

---

## **RETURN FOR REPAIR POLICY**

Every effort has been made to provide you with a reliable product of superior quality. However, in the event your instrument requires repair, please contact our Customer Service to obtain an RGA (Return Goods Authorization) number before forwarding the unit via prepaid freight to the attention of our Service Center at this address:

General Tools & Instruments  
80 White Street  
New York, NY 10013  
212-431-6100

Remember to include a copy of your proof of purchase, your return address, and your phone number and/or e-mail address.



**GENERAL<sup>®</sup>**

**Specialty Tools & Instruments**

**T**  **USA**  
**Equipment**  
**.NET**

An Interworld Highway, LLC Company