

# AC/DC Clamp Meter CM4370 Series

Tetsuya Nakamura

Engineering Division 5, Engineering Department

**Abstract**—The AC/DC Clamp Meter CM4370 series (consisting of the CM4371, CM4372, CM4373, and CM4374) is a line of true RMS clamp meters that can measure AC and DC currents. The instruments were developed by Hioki with a rugged design so as to enable professionals to do their jobs quickly under a range of challenging environmental conditions.

## I. INTRODUCTION

The clamp meter is a basic tool for electrical measurement that combines multiple functions, including current, voltage, continuity, and resistance measurement, in a single instrument. Clamp meters are used in a variety of applications, including to check load current (i.e., to check breaker capacity) in electrical equipment in buildings and plants as well as solar power systems, to carry out maintenance inspections of electrical equipment, and to check electrical wiring work. Hioki has offered a range of clamp meters for many years. Most recently, it developed the CM4370 series to meet user demand for a high level of convenience.

## II. OVERVIEW AND PRODUCT CONCEPT

The CM4370 series is a line of clamp meters that are capable of true RMS measurement.

The CM4371/CM4372 offers current measurement functionality with 20.00 A and 600.0 A ranges, while the CM4373/CM4374 offers current measurement functionality with 600.0 A and 2000 A ranges. Apart from the current ranges, all four instruments offer the same measurement functionality.

In addition, the CM4372/CM4374 provides Bluetooth communications functionality, enabling it to send data to a smartphone or tablet.

During the product planning stage, Hioki engineers solicited feedback from numerous users as they sought to determine what kind of product the market required, and they took that feedback into account by applying it to the products' designs. As a result of this effort, designers identified what would become the core concept—a line of rugged clamp meters engineered to enable professionals to do their jobs quickly under a range of challenging environmental conditions—based on a desire to contribute to improved work efficiency in a variety of measurement settings and environments. To deliver faster measurement speed, greater convenience, and improved environmental resistance under this concept, the new-product development



Appearance of the CM4371 and the CM4373.

project implemented the features and functions described below.

## III. FEATURES AND FUNCTIONS

### A. High-Speed Response for Measured Values

The CM4370 series delivers some of the world's fastest measurement times (as of January 2016), for example implementing a response time of approximately 0.7 s when measuring a 100 V, 50 Hz AC voltage.

Series instruments incorporate a dedicated IC that brings together proprietary Hioki circuit control technologies and digital signal processing technologies.

### B. Automatic AC/DC Detection

The user need only set the rotary switch to current measurement or voltage measurement in order for the instrument to automatically detect whether the target current or voltage is AC or DC and measure it accordingly. By eliminating the need to change the switch's setting in situations where AC and DC currents or voltages are mixed, this feature can prevent the need to repeat work later due to measurement mistakes.

### C. Automatic Hold

Once the measured value has stabilized, the instruments beep and automatically retain the displayed value. This feature was adopted to eliminate the inconvenience of not being able to see the clamp meter's measured value display,

## AC/DC Clamp Meter CM4370 Series

which is particularly vexing during current measurement, and of the HOLD button being difficult to operate.

### D. Inrush Current Measurement (INRUSH)

The CM4370 series can simultaneously measure the RMS value and maximum peak value of inrush current, a phenomenon that characterizes motor startup and welding machine operation. Whereas typical clamp meters measure inrush current over an interval of 100 ms and then calculate the RMS value, this function measures inrush current only during the interval of its occurrence (ranging from several dozen to several hundred milliseconds in duration), enabling it to calculate more accurate RMS values.

### E. DC Measurement Polarity Detection Function

This function beeps and uses a warning backlight to alert the user if DC current or DC voltage measurement yields a negative value. It is ideally suited to finding improperly wired connections in solar power systems and other equipment that has numerous DC wires.

### F. Filter Function for Inverter Measurement

CM4370 series clamp meters provide filter functionality that enables measurement approximating the fundamental wave component of the target by eliminating the inverter's carrier component. The filter's cutoff frequency is 100 Hz based on the assumption that the fundamental frequency will range from 45 Hz to 100 Hz.

### G. Extensive Measurement Functionality

In addition to current and voltage measurement, the CM4370 series provides functionality for measuring frequency, continuity, resistance, diodes, capacitance, temperature, voltage detection, and DC power. Current and voltage measurement also provide functionality for measuring AC+DC signals.

In addition, despite being clamp meters, these instruments are able to measure DC voltages of up to 1700 V. By combining an extensive range of measurement functions in a single instrument, they allow technicians to carry fewer instruments when working in the field.

### H. Improved Environmental Resistance

Users demand improved environmental resistance to eliminate inconvenience that arises from a narrow operating temperature range during the summer and in cold locations. An operating temperature range of  $-25^{\circ}\text{C}$  to  $65^{\circ}\text{C}$  ( $-13^{\circ}\text{F}$  to  $149^{\circ}\text{F}$ ) ensures that the CM4370 series instruments can be used in tropical regions where the daytime temperature exceeds  $40^{\circ}\text{C}$  ( $104^{\circ}\text{F}$ ).

Each instrument's current sensor and grip feature dust and water resistance of IP50 and IP54, respectively, indicating that measurement functionality is maintained

without ingress of particulate matter such as sand or dust or water droplets such as rain.

### I. Safety

The CM4370 series delivers world-class safety by complying with the CAT IV (600 V)/CAT III (1000 V) measurement categories. The instruments can safely measure service drops and distribution panels with voltages of up to 600 V relative to ground, and the design delivers the requisite safety to withstand a transient overvoltage of 8 kV in the event that lightning were to strike near a measurement site, causing an impulse waveform to be superposed on the service line.

### J. Dual-Value Display and Backlight

In addition to incorporating a large display with a wide viewing angle, the CM4370 series clamp meters are capable of displaying dual values so that users can, for example, simultaneously read measured values for both AC current and frequency.

The series uses a white backlight to provide maximum visibility in dim locations. To prevent wasteful battery consumption caused by inadvertent backlight activation, the instruments also provide auto-off functionality that turns off the display after a certain amount of time has elapsed.

In the event that a short-circuit is detected during a continuity check or the clamp meter's maximum input range is exceeded, the instruments warn the user of the hazard by turning the backlight red and beeping.

### K. Functional Design

While the basic form factor is little changed from legacy products, the new models feature a functional design that facilitates intuitive operation thanks to features such as a large, easy-to-see display and colored control keys that help users identify keys based on their function. In addition, two-color molding allows the grip to be covered with an elastomer so that it better fits the shape of the user's hand.

## IV. ARCHITECTURE

### A. Hardware Architecture

1) *Overview:* Fig. 1 provides a block diagram for the CM4370 series instruments. Measurement is performed by a dedicated IC, while the CPU controls the display, control keys, and other related aspects of operation. To boost convenience, a single rotary switch provides access to multiple measurement functions (AC, DC, etc.).

2) *Current measurement circuit:* The current measurement circuit consists of a constant-current circuit that drives the Hall elements used to detect current and an amplification circuit that amplifies the output from the Hall elements. While the specific design of peripheral circuitry varies due to differences in each instrument's rated current,

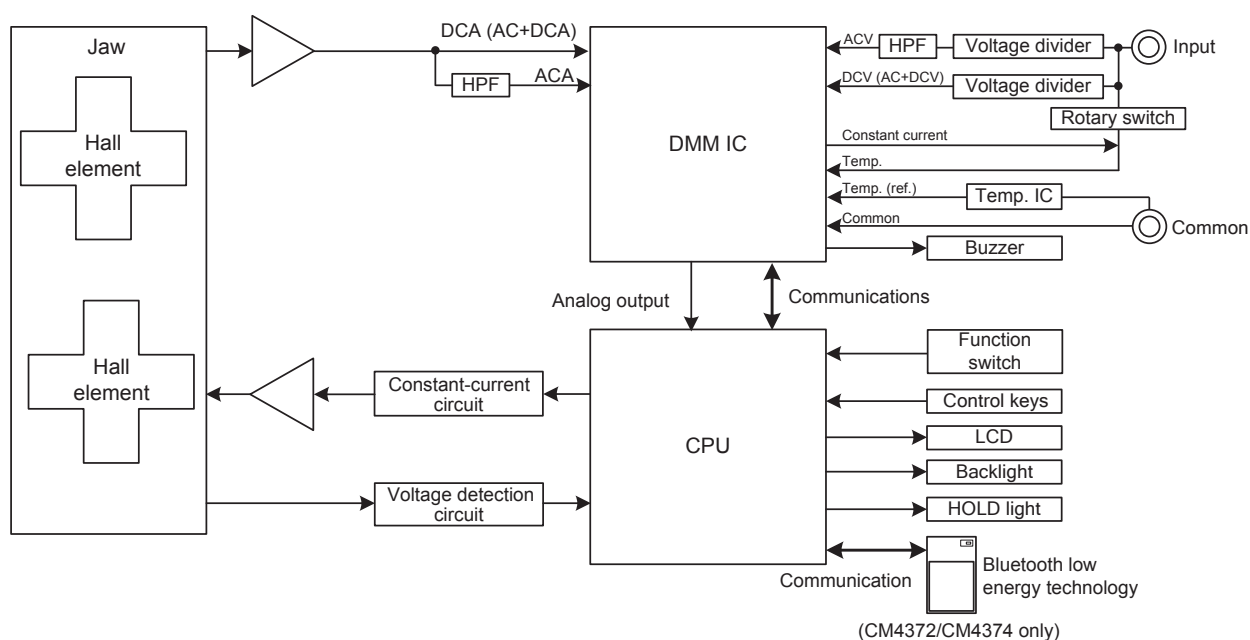

Fig. 1. CM4370 series block diagram.

all models in the CM4370 series instruments share the same basic circuit architecture.

### B. Dedicated IC

The CM4370 clamp meters feature a dedicated IC. This IC, which takes the form of a digital multimeter ASIC with mixed analog and digital components, incorporates analog switches, various amplifiers, and a constant-current circuit, among other circuitry. The IC also has a built-in 14-bit  $\Delta\Sigma$ -type A/D converter for measurement signal conversion, enabling it to calculate RMS values. Implementation of all functionality required for measurement functionality on a single IC helped shrink the product.

### C. Current Sensor

Two Hall elements, which are used for current detection, are located in the top and bottom jaws. Output from these two components is adjusted in order to reduce the effects of the position of the conductor inside the jaws and thereby enable stable measurement.

### D. Control Circuitry

1) *CPU*: The CPU controls the control keys, display, measurement data communications, and dedicated IC. In the CM4372/CM4374, it also performs processing to implement communication with smartphones and other supported devices.

2) *Display and backlight*: The CM4370 series clamp meters feature an FSTN liquid crystal display with a white background for increased visibility. The display is semi-transmissive so that it can be viewed even when the backlight

has been disabled in order to reduce power consumption for longer battery life.

The LCD has a white LED to provide good visibility in dim locations, and a light guide plate serves to distribute the light uniformly.

3) *Bluetooth communications*: The CM4372/CM4374 incorporates Bluetooth technology (Bluetooth low energy technology), enabling measured values to be sent to a smartphone or tablet in real time. Although transmission antenna power is limited to approximately 1 mW, the instruments deliver a communications range of about 10 m (10.9 yd.) if there is a clear, obstacle-free line of sight to the paired device.

### E. Power Supply

The instruments use readily available, AAA alkaline dry-cell (LR03) batteries as their power supply for increased convenience. The CM4370 series is designed to operate on two dry-cell batteries to deliver increased portability.

The CM4371 and CM4373 delivers continuous operating time of about 45 hours, compared to about 24 hours for the CM4372/CM4373, which is equipped with Bluetooth.

### F. Software

1) *Automatic AC/DC detection*: The instruments detect whether a given current is AC or DC by performing calculations using RMS and mean values measured by the dedicated IC.

2) *Fast auto-range switching and stable measurement*: To shorten the amount of time required to transition between ranges, the instruments implement accelerated operation by

## AC/DC Clamp Meter CM4370 Series

switching data processing and filter settings while doing so. After the range switch is complete, they switch back to the normal settings to reduce display variability.

3) *Smartphone apps*: Hioki developed apps for devices running Android 4.3 or later and iOS 8 or later (iPhone, iPad, iPad mini, iPad Pro, iPod Touch). These apps let users save measured values from the CM4370 series and combine them with site photographs, handwritten memos, and other information to create PDF reports.

- General Measurement (manual measurement)

The apps can connect to up to eight instruments simultaneously, and they provide functionality not only for observing measured values in real time, but also for performing calculations between channels and automatically saving measured values when the user presses the instrument's HOLD button. In particular, this auto-save function can be combined with the instrument's auto-hold function to save measured values without requiring the user to touch either the instrument or the smartphone. This capability is extremely convenient when measuring a large number of points.

- Logging (Recording) (automatic measurement)

The apps provide functionality for logging up to eight channels at a minimum logging interval of 5 s (if logging one channel only, 1 s) over a maximum continuous logging time of 24 hours. They can display the maximum, minimum, and average values during the logging period, which is useful when users need to perform small-scale, short-term data analysis that does not merit preparing a complex logger setup.

- Waveform Graph

The instruments provide a simple oscilloscope function that can observe DC as well as 10 Hz to 1 kHz current and voltage waveforms. This functionality allows users to observe the waveforms of large currents of up to 2000 A (for the CM4372, 600 A) and high voltages of up to 1700 V without the need to provide an oscilloscope or special probe. Consequently, the app gives a single smartphone outstanding analytical capability for investigating anomalies that may occur unexpectedly at worksites.

- Inrush download function

When performing inrush current (INRUSH) measurement, waveforms and measured values are automatically saved in the instrument's memory. Consequently, even if they have not established a Bluetooth connection with a smartphone during measurement, users can connect one later to review the waveforms. Data from the last two measurements can be retained in the instrument's memory.

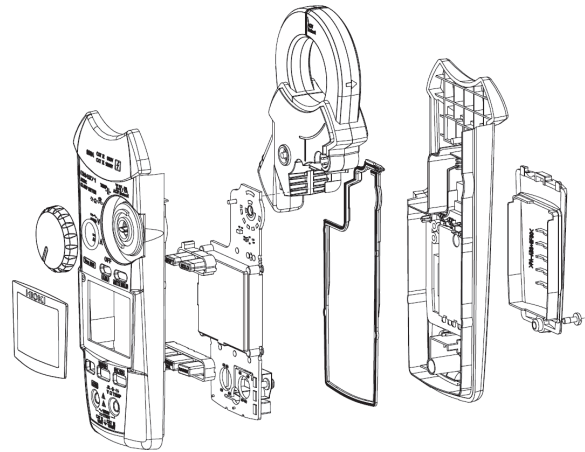

Fig. 2. Exploded view of a CM4370 series instrument.

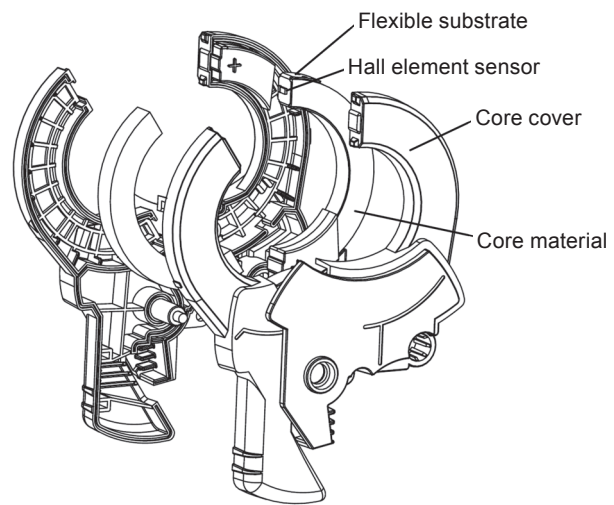

Fig. 3. CM4371 sensor construction.

### G. Construction

1) *Instrument*: Fig. 2 provides an exploded view of a CM4370 series clamp meter. The grip is fashioned using two-color molding, and a soft elastomer coating on the grip and rotary switch ensures good grip and improved operability.

The rotary switch has been positioned on the right side of the front of the instrument to allow single-handed operation.

The fit between the upper and lower cases incorporates a gasket to deliver the high level of dust and water resistance (grip: IP54) that is a key feature of the CM4370 series. In the battery compartment, a tight fit between the soft elastomer on the outside of the instrument and the molded battery cover ensures excellent dust and water resistance.

2) *Current sensor*: Fig. 3 illustrates the construction of the CM4371's sensor. Oriented steel strips, which provide good magnetic saturation characteristics, are used as the core material in a split-type magnetic circuit. The Hall elements located at the break in the circuit detect the magnetic flux



in the gap. Since the magnetic flux density varies with the gap dimensions, high-strength glass-fiber-reinforced polycarbonate is used for the sensor covers, which form the tips where the jaws contact each other, in order to reduce variations in gap dimensions.

Voltage detection is implemented by means of a voltage detection pattern on a flexible substrate that is integrated into the sensor. The flexible substrate is positioned so that it covers the tip of the jaw so that voltage detection is performed at the sensor tip.

#### H. Characteristics

1) *Temperature characteristics:* Figs. 4 and 5 illustrate the CM4372's temperature characteristics. Compared to previous products, the CM4370 series implements a broader operating temperature range. The instruments provide an adequate margin for their accuracy specifications at both high and low temperatures and deliver a high level of stability.

2) *Response time:* Fig. 6 illustrates measurement results for response time for the CM4373 and a legacy product, Hioki's Clamp On AC/DC HiTester 3285-20. The graph, which illustrates the amount of time elapsed from application of input to display stabilization during auto-range operation, indicates that the CM4373's response times for voltage and current measurement were half those of the 3285-20.

#### V. CONCLUSION

The CM4370 series was commercialized as a line of rugged clamp meters enable professionals to do their jobs quickly under a range of challenging environmental conditions. Hioki is confident that by offering convenient functionality for measuring current at worksites and delivering improved environmental resistance, the instruments in the series will prove to be useful tools by boosting the efficiency of time-sensitive work. It is the company's hope that these products will empower professionals to do their jobs more efficiently.

Takashi Hirao<sup>\*1</sup>, Yuta Akamatsu<sup>\*1</sup>, Satoshi Imaizumi<sup>\*2</sup>,  
Tetsuya Yoshiike<sup>\*3</sup>, Hikaru Kodama<sup>\*4</sup>

#### REGISTERED TRADEMARKS

- Bluetooth is a registered trademark of Bluetooth SIG, Inc. (USA).
- Android is a registered trademark of Google, Inc.
- IOS is a registered trademark of Cisco in the U.S. and other countries.
- iPhone, iPad, iPad mini, iPad Pro, and iPod touch are registered trademarks or trademarks of Apple Inc. in the U.S. and other countries.

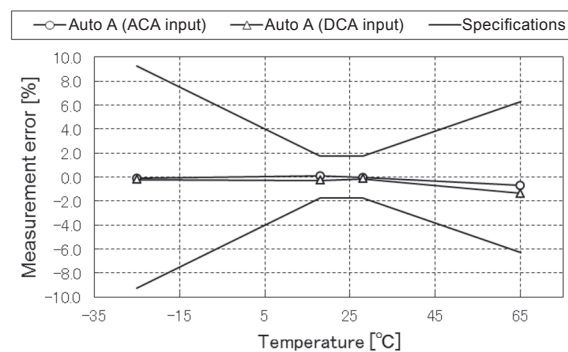

Fig. 4. Temperature characteristics: Current measurement (20.00 A range with 18 A input).

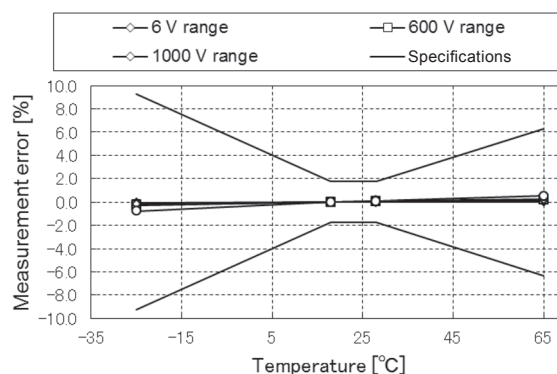

Fig. 5. Temperature characteristics: Voltage measurement (f.s. input, multiple ranges).

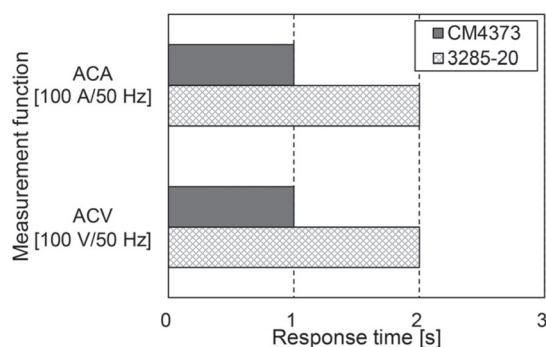

Fig. 6. Difference in response time vs. 3285-20 (legacy product).

\*1 Engineering Division 5, Engineering Department  
\*2 Engineering Department  
\*3 Engineering Division 10, Engineering Department  
\*4 Development Assistance Division, Development Assistance Department

